UNIVERSITI SAINS MALAYSIA

Peperiksaan Semester Pertama
Sidang Akademik 2003/2004

September/Oktober 2003

IEK 101/3 – PENGHITUNGAN PROSES KIMIA

Masa : 3 jam

Sila pastikan bahawa kertas peperiksaan ini mengandungi ENAM BELAS (16) mukasurat yang bercetak sebelum anda memulakan peperiksaan ini.

Wajib jawab soalan 5 dan 6. Pilih 3 dari soalan 1 hingga 4. Semua soalan mesti dijawab dalam Bahasa Malaysia.

...2/-

1. Gambarajah berikut merupakan satu operasi yang melibatkan satu penyejat dan satu penghablur. Data operasi adalah seperti ditunjukkan. Kirakan kadar arus edarulang R dalam unit kg/h.

Penyelesaian:

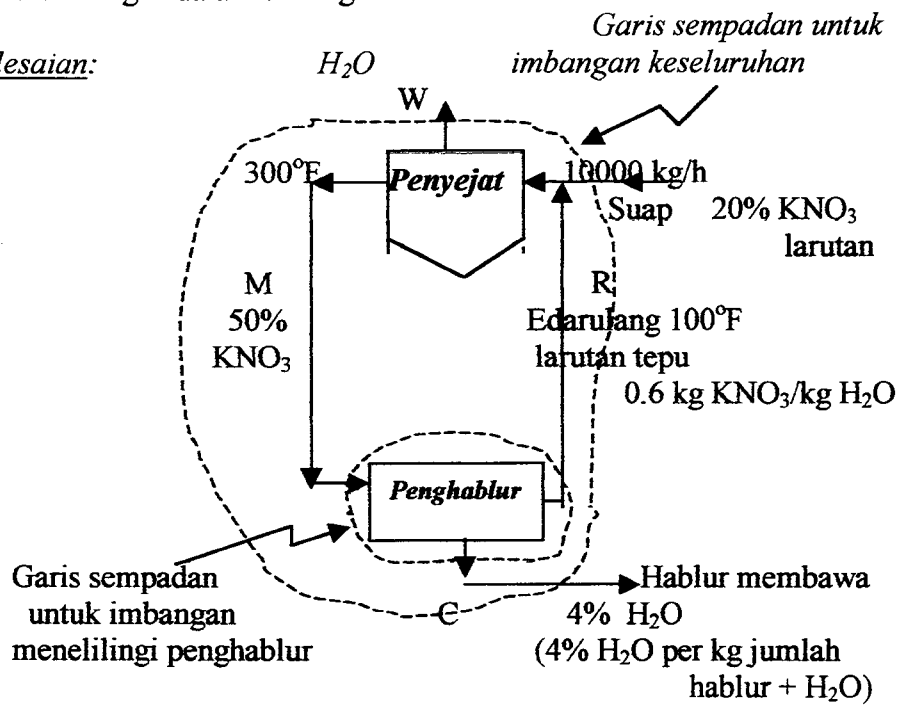

Untuk arus edarulang,
 Dasar: 1 kg H_2O

2. Argentum logam boleh didapati daripada bijih sulfida melalui proses memanggang untuk menjadi sulfat, melarutleleh dengan air, dan memendap argentum dengan kuprum. Dalam gambarajah berikut, bahan yang meninggalkan pemisah kedua mengandungi 90% argentum dan 10% kuprum. Untuk 1000 kg bahan dikeluarkan dari S₂, tentukan amaun Cu. Jika tindak balas berlaku hingga 75% sempurna berdasarkan bahan tindak balas terhadap Ag₂SO₄, apakah arus edarulang dalam unit kg ?

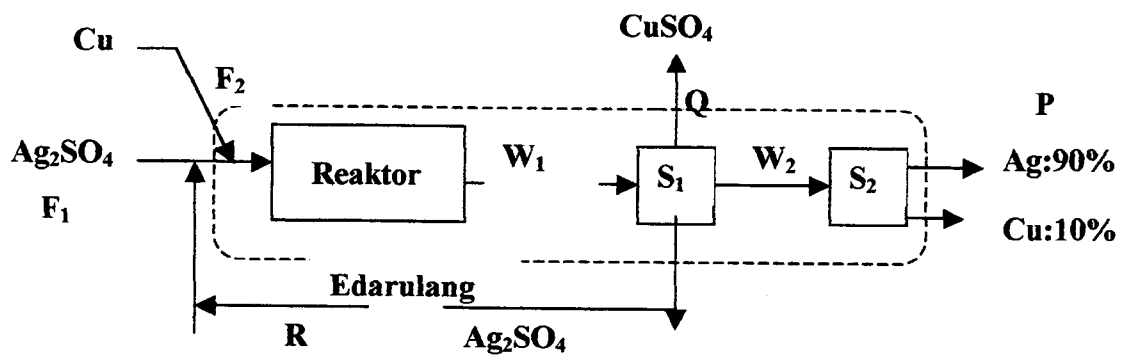
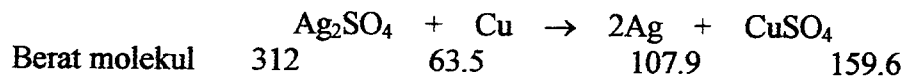

Dasar: 1000 kg bahan keluar dari S₂

Dariimbangan keseluruhan: zat ikat : Ag, SO_4^-

...4/-

3. Karbon monoksida pada 200°C dibakar pada tekanan atmosfera dengan udara kering pada 500°C yang dibekalkan 90% kelebihan daripada yang diperlukan secara teoretis. Hasil-hasil pembakaran meninggalkan kamar tindak balas pada 1000°C. Berapakah yang dikeluarkan dari tindak balas itu dalam unit kcal/kg-mol CO terbakar. Anggapkan proses pembakaran itu sempurna dan N_2 hadir didalam udara.

Dasar : 1.0 kg-mol CO.

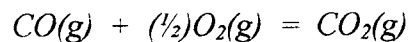

$$\text{Data: } \Delta H_{25} = -67636 \text{ kcal}$$

Untuk entalpi bahan-bahan tindak balas (H_R) relatif dengan keadaan standard pada 25°C, gunakan C_{pm} = muatan haba molal purata antara 25°C dengan T°C.

$$\text{Bagi CO: } C_{pm} = 7.017 \text{ cal/g-mol-K}$$

$$\text{Bagi udara: } C_{pm} = 7.225 \text{ cal/g-mol-K}$$

$$\text{Bagi CO}_2: C_{pm} = 11.92 \text{ cal/g-mol-K}$$

$$\text{Bago O}_2: C_{pm} = 7.941 \text{ cal/g-mol-K}$$

$$\text{Bagi N}_2: C_{pm} = 7.507 \text{ cal/g-mol-K}$$

$$\Delta H = \sum(H_p + \Delta H_{25}) - \sum H_R$$

di mana $\sum H_p$ = jumlah entalpi bagi semua hasil dari tindak balas, merujuk kepada keadaan standard pada 25°C.

ΔH_{25} = haba tindak balas standard.

$\sum H_R$ = jumlah entalpi semua bahan tindak balas yang terlibat relatif dengan keadaan rujukan haba tindak balas standard, 25°C dan 1 atm.

***Sila lihat lampiran untuk Data.**

...5/-

4. (a) Hitungkan haba tindak balas standard untuk tindak balas berikut:

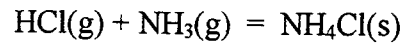

$$\begin{array}{ll} \text{HCl(g)} & \Delta H_f = ? \\ \text{NH}_3(\text{g}) & \Delta H_f = ? \\ \text{NH}_4\text{Cl(s)} & \Delta H_f = ? \end{array}$$

$$\therefore \Delta H_{25} = ?$$

- (b) Hitungkan haba tindak balas standard ΔH_{25} untuk tindak balas berikut.

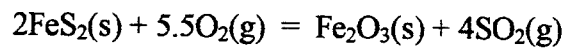

$$\begin{array}{ll} \text{FeS}_2(\text{s}) & \Delta H_f = ? \\ \text{Fe}_2\text{O}_3(\text{s}) & \Delta H_f = ? \\ \text{SO}_2(\text{g}) & \Delta H_f = ? \end{array}$$

$$\Delta H_{25} = ?$$

- (c) Hitungkan haba tindak balas standard ΔH_{25} untuk tindak balas berikut:

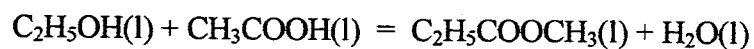

$$\begin{array}{ll} \text{C}_2\text{H}_5\text{OH} & \Delta H_c = ? \\ \text{CH}_3\text{COOH} & \Delta H_c = ? \\ \text{C}_2\text{H}_5\text{COOCH}_3 & \Delta H_c = ? \end{array}$$

$$\therefore \Delta H_{25} = ?$$

$$[\Delta H_{\text{tindak balas}} = \sum \Delta H_{\text{c(bahan)}} - \sum \Delta H_{\text{c(basil)}}]_{25\text{oC}}$$

***Sila lihat lampiran untuk Data.**

5. (a) Penuhkan jadual berikut bagi air:

Suhu($^{\circ}\text{C}$)	Tekanan (kPa)	h (kJ/kg)	x (kualiti)	Penerangan Fasa
500		3420		
	600		0.3	
200	400			

(40 markah)

- (b) Satu bekas tegar 0.4m^3 pada mulanya mengandungi campuran cecair wap tepu H_2O pada 100°C . Air dipanaskan sehingga mencapai keadaan kritikal. Tentukan jisim cecair H_2O dan isipadu yang diambil oleh cecair H_2O pada keadaan mula. Lakarkan proses merujuk kepada garisan tepu.

(30 markah)

- (c) Air tepu sebanyak 300g diwapkan sepenuhnya pada suhu malar 150°C . Tentukan

- i) perubahan tenaga dalaman
- ii) perubahan isipadu
- iii) tekanan semasa proses ini berlaku
- iv) lakarkan proses dalam gambarajah T-v merujuk kepada garisan tepu.

(30 markah)

...7/-

6. (a) Tentukan isipadu spesifik bagi wap panas lampau (H_2O) pada 15MPa dan $600^\circ C$ menggunakan:

- i) persamaan gas unggul
- ii) jadual stim
- iii) carta kebolehmampatan teritlak

Kaedah manakah akan memberi nilai yang paling jitu?

(40 markah)

- (b) Satu campuran gas yang terdiri daripada 15 lb N_2 dan 20 lb H_2 berada pada tekanan 50 psig dan suhu $60^\circ F$. Tentukan yang berikut dengan menganggap bahawa campuran ini adalah unggul.

- (a) tekanan separa bagi setiap komponen
- (b) isipadu spesifik bagi campuran
- (c) ketumpatan campuran

(40 markah)

- (c) Satu gas memenuhi $1 m^3$ pada tekanan piawai dikembangkan kepada $1.2m^3$, pada suhu malar. Apakah nilai tekanan baru?

(20 markah)

Keadaan Standard Biasa bagi Gas Unggul

Sistem	T	p	\hat{V}
SI	273.15K	101.325 kPa	22.415 m ³ /kg mol
Universal scientific	0.0°C	760 mm Hg	22.415 liters/g mol
Natural gas industry	60.0°C	14.696 psia (15.0°C)	379.4 ft ³ /lb mol (101.325 kPa)
American engineering	32°F	1 atm	359.05 ft ³ /lb mol

FIGURE A-30b

Nelson-Oberth generalized compressibility chart—intermediate pressures. (Used with permission of Dr. Edward E. Obert, University of Wisconsin.)



(b) $0 < P_r < 7$

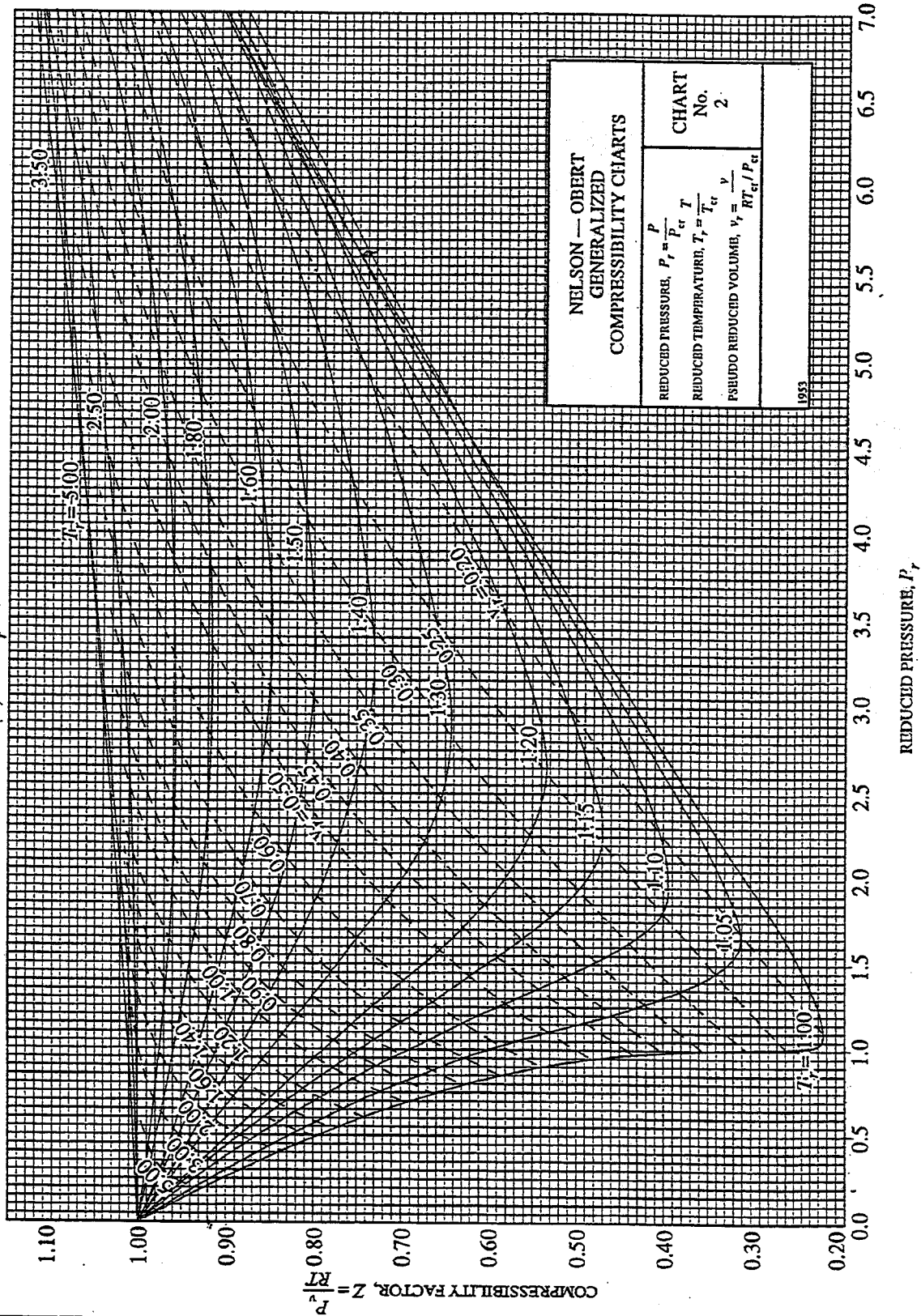

...10/-

FIGURE A-30c
 Nelson-Obert generalized compressibility chart—high pressures. (Used with permission of Dr. Edward E. Obert,
 University of Wisconsin.)

(c) $0 < P_r < 40$

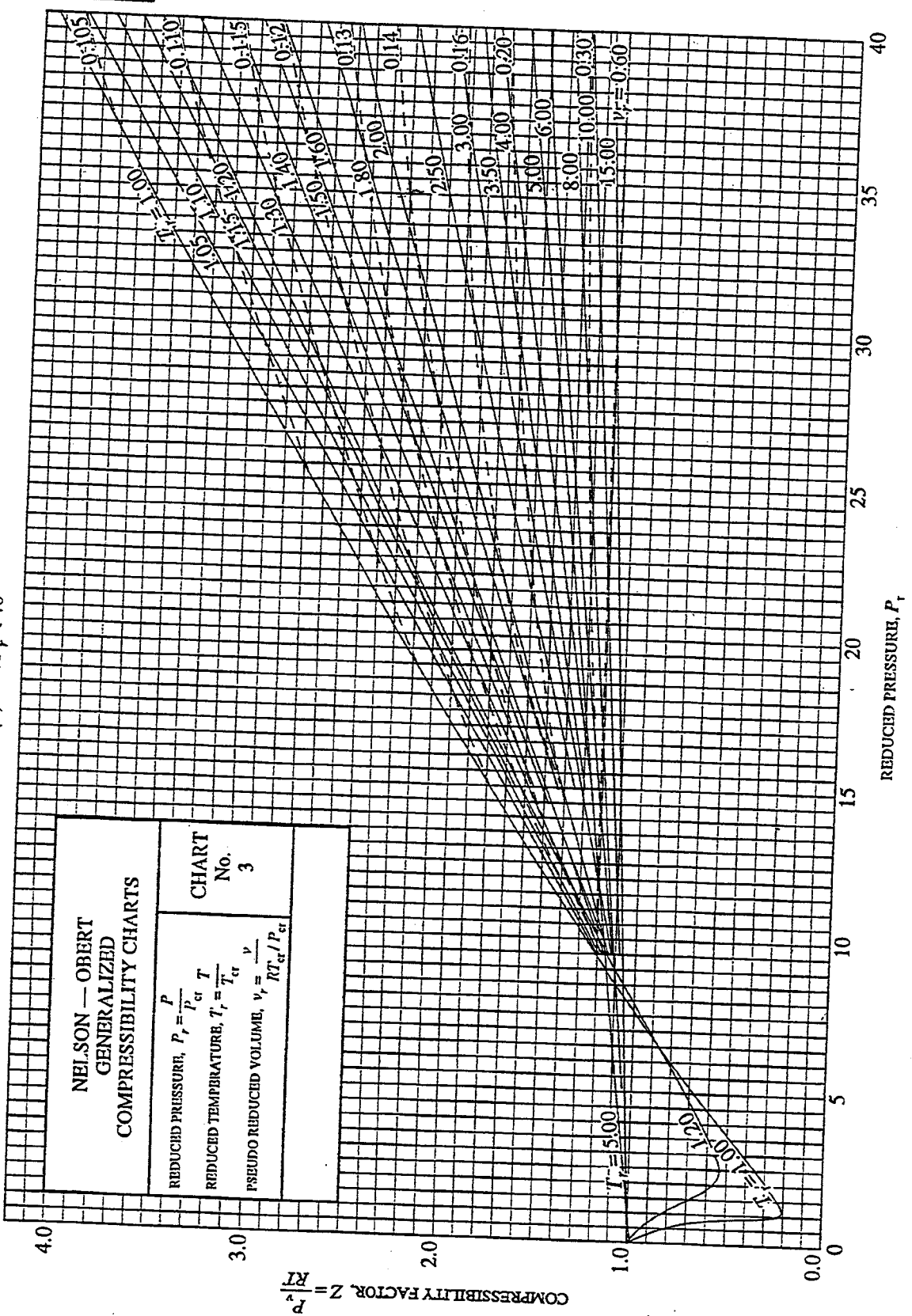

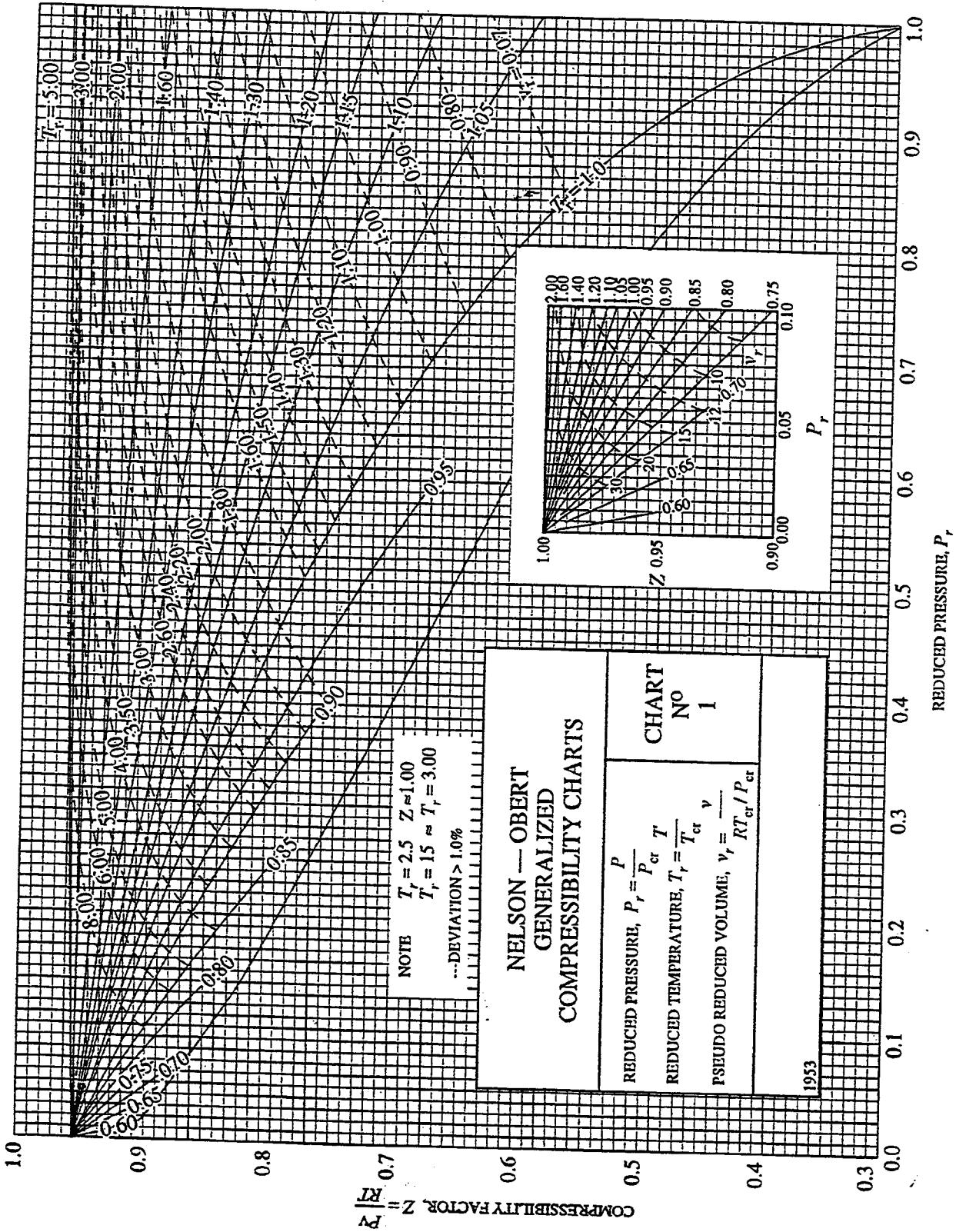

TABLE HEATS OF FORMATION AND SOLUTION

Reference Conditions: 25° C (298.16° K), 1 atm pressure, gaseous substances in ideal state.

ΔH_f° = standard heat of formation, kcal per g-mole

ΔH_s° = standard integral heat of solution, kcal per g-mole

Multiply values by 1000 to obtain g-cal per g-mole, or kcal per kg-mole.

Multiply values by 1800 to obtain Btu per lb-mole.

Source: *Selected Values of Chemical Thermodynamic Properties*, as of July 1, 1953, edited by D. D. Wagman, National Bureau of Standards.

Abbreviations

c = crystalline state

l = liquid state

g = gaseous state

dil = in dilute aqueous solution

∞ = infinite dilution

ppt = precipitated solid

amorph = amorphous state

Compound	Formula	State	ΔH_f° , Heat of Formation	Moies of Water	ΔH_s° , Heat of Solution
Acetic acid	CH ₃ COOH	<i>l</i>	-116.4	∞	-0.343
Aluminum chloride	AlCl ₃	<i>c</i>	-166.2	600	-79.3
Aluminum hydroxide	Al(OH) ₃	<i>amorph</i>	-304.2		
Aluminum oxide	Al ₂ O ₃	Corundum, <i>c</i>	-399.09		
Aluminum silicate	Al ₂ SiO ₅	Sillimanite, <i>c</i>	-648.9		
Aluminum sulfate	Al ₂ (SO ₄) ₃	<i>c</i>	-820.98	∞	-76.12
Ammonia	NH ₃	<i>g</i>	-11.04	∞	-8.23
Ammonia	NH ₃	<i>l</i>	-16.06	∞	-3.26
Ammonium carbonate	(NH ₄) ₂ CO ₃	<i>dil</i>	-225.11		
Ammonium bicarbonate	(NH ₄)HCO ₃	<i>c</i>	-203.7	∞	+6.73
Ammonium chloride	NH ₄ Cl	<i>c</i>	-75.38	∞	+3.62
Ammonium hydroxide	NH ₄ OH	<i>in 1 H₂O</i>	-87.64		
Ammonium nitrate	NH ₄ NO ₃	<i>c</i>	-87.27	∞	+6.16
Ammonium oxalate	(NH ₄) ₂ C ₂ O ₄	<i>c</i>	-268.72	2100	+8.12
Ammonium sulfate	(NH ₄) ₂ SO ₄	<i>c</i>	-231.36	∞	+1.48
Ammonium acid sulfate	(NH ₄)HSO ₄	<i>c</i>	-244.83	800	-0.76
Antimony trioxide	Sb ₂ O ₃	<i>c</i>	-168.4	∞	+1.9
Antimony pentoxide	Sb ₂ O ₅	<i>c</i>	-234.4	∞	+8.0
Antimony sulfide	Sb ₂ S ₃	<i>c</i>	-43.5		
Arsenic acid	H ₃ AsO ₄	<i>c</i>	-215.2	∞	+0.4
Arsenic trioxide	As ₂ O ₃	<i>monoclinic, c</i>	-156.4	∞	+6.7
Arsenic pentoxide	As ₂ O ₅	<i>c</i>	-218.6	∞	-6.0
Arsine	AsH ₃	<i>g</i>	41.0		
Barium acetate	Ba(C ₂ H ₃ O ₂) ₂	<i>c</i>	-355.1	400	-6.4
Barium carbonate	BaCO ₃	<i>c</i>	-291.3		
Barium chlorate	Ba(ClO ₃) ₂	<i>c</i>	-181.7	∞	+6.1
Barium chloride	BaCl ₂	<i>c</i>	-205.56	∞	-3.16
Barium chloride	BaCl ₂ ·2H ₂ O	<i>c</i>	-349.35	∞	+4.00
Barium hydroxide	Ba(OH) ₂	<i>c</i>	-226.2	∞	-12.38
Barium oxide	BaO	<i>c</i>	-133.4	∞	-36.9
Barium peroxide	BaO ₂	<i>c</i>	-150.5		
Barium silicate	BaSiO ₃	<i>c</i>	-359.5		
Barium sulfate	BaSO ₄	<i>c</i>	-350.2	∞	+4.63
Barium sulfide	BaS	<i>c</i>	-106.0	∞	-12.4
Bismuth oxide	Bi ₂ O ₃	<i>c</i>	-137.9		
Boric acid	H ₃ BO ₃	<i>c</i>	-260.2	∞	+5.0
Boron oxide	B ₂ O ₃	<i>c</i>	-302.0	∞	-3.45
Bromine chloride	BrCl	<i>g</i>	+3.51		
Cadmium chloride	CdCl ₂	<i>c</i>	-93.0	∞	-4.39
Cadmium oxide	CdO	<i>c</i>	-60.86		

Compound	Formula	State	ΔH°_f , Heat of Formation	Moles of Water	ΔH°_s , Heat of Solution
Cadmium sulfate	CdSO ₄	<i>c</i>	-221.36	∞	-12.84
Cadmium sulfide	CdS	<i>c</i>	-34.5		
Calcium acetate	Ca(C ₂ H ₃ O ₂) ₂	<i>c</i>	-355.0	∞	-7.5
Calcium aluminate	CaO·Al ₂ O ₃	<i>glass</i>	-545		
Calcium aluminate	2CaO·Al ₂ O ₃	<i>glass</i>	-695		
Calcium aluminate	3CaO·Al ₂ O ₃	<i>glass</i>	-848		
Calcium aluminum silicate	3CaO·Al ₂ O ₃ ·2SiO ₂	<i>c</i>	-1303		-7.5
Calcium aluminum silicate	CaO·Al ₂ O ₃ ·6SiO ₂	<i>c</i>	-1828		
Calcium carbide	CaC ₂	<i>c</i>	-15.0		
Calcium carbonate	CaCO ₃	Calcite, <i>c</i>	-288.45		
Calcium chloride	CaCl ₂	<i>c</i>	-190.0	∞	-19.82
Calcium chloride	CaCl ₂ ·6H ₂ O	<i>c</i>	-623.15	∞	+3.43
Calcium fluoride	CaF ₂	<i>c</i>	-290.3		
Calcium hydroxide	Ca(OH) ₂	<i>c</i>	-235.80	∞	-3.88
Calcium nitrate	Ca(NO ₃) ₂	<i>c</i>	-224.0	∞	-4.51
Calcium oxalate	CaC ₂ O ₄ ·H ₂ O	<i>c</i>	-399.1		
Calcium oxide	CaO	<i>c</i>	-151.9	∞	-19.46
Calcium phosphate	Ca ₃ (PO ₄) ₂	<i>c, α</i>	-986.2		
Calcium silicate	CaSiO ₃	(Wollasto- nite, <i>c</i>)	-378.6		
Calcium silicate	Ca ₂ SiO ₄	<i>c, β</i>	-538.0		
Calcium sulfate	CaSO ₄	Anhydrite, <i>c</i>	-342.42	∞	-4.25
Calcium sulfide	CaS	<i>c</i>	-115.3	∞	-4.5
Carbon graphite	C	<i>c</i>	0		
Diamond	C	<i>c</i>	+0.4532		
Amorphous (in coke)	C	<i>amorph</i>	+2.6		
Carbon monoxide	CO	<i>g</i>	-26.4157		
Carbon dioxide	CO ₂	<i>g</i>	-94.0518	∞	-4.64
Carbon disulfide	CS ₂	<i>g</i>	+27.55		
Carbon disulfide	CS ₂	<i>l</i>	+21.0		
Carbon tetrachloride	CCl ₄	<i>g</i>	-25.50		
Carbon tetrachloride	CCl ₄	<i>l</i>	-33.34		
Chloric acid	HClO ₃	<i>dil</i>	-23.50		
Chromium chloride	CrCl ₃	<i>c</i>	-134.6		
Chromium chloride	CrCl ₂	<i>c</i>	-94.56	∞	-18.64
Chromium oxide	Cr ₂ O ₃	<i>c</i>	-269.7		
Chromium trioxide	CrO ₃	<i>r</i>	-138.4	80	-2.5
Cobalt oxide	CoO	<i>c</i>	-57.2		
Cobalt oxide	Co ₃ O ₄	<i>c</i>	-210		
Cobalt chloride	CoCl ₂	<i>c</i>	-77.8		
Cobalt sulfide	CoS	<i>ppt</i>	-21.4		
Copper acetate	Cu(C ₂ H ₃ O ₂) ₂	<i>c</i>	-213.2	∞	-2.7
Copper carbonate	CuCO ₃	<i>c</i>	-142.2		
Copper chloride	CuCl ₂	<i>c</i>	-52.3	in aq. HCl	-6.3
Copper chloride	CuCl	<i>c</i>	-32.5		
Copper nitrate	Cu(NO ₃) ₂	<i>c</i>	-73.4	800	-10.4
Copper oxide	CuO	<i>c</i>	-37.1		
Copper oxide	Cu ₂ O	<i>c</i>	-39.84		
Copper sulfate	CuSO ₄	<i>c</i>	-184.00	∞	-17.51
Copper sulfide	CuS	<i>c</i>	-11.6		
Copper sulfide	Cu ₂ S	<i>c</i>	-19.0		
Cyanogen	C ₂ N ₂	<i>g</i>	+73.60		
Hydrobromic acid	HBr	<i>g</i>	-8.66	∞	-20.24
Hydrochloric acid	HCl	<i>g</i>	-22.063	∞	-17.960
Hydrocyanic acid	HCN	<i>g</i>	+31.2	∞	-6.0
Hydrofluoric acid	HF	<i>g</i>	-64.2	∞	-14.46

Compound	Formula	State	ΔH_f° , Heat of Formation	Moles of Water	ΔH_{sol}° , Heat of Solution
Hydriodic acid	HI	<i>g</i>	+8.20	∞	-19.57
Hydrogen oxide	H ₂ O	<i>g</i>	-57.7979		
Hydrogen oxide	H ₂ O	<i>l</i>	-68.3174		
Hydrogen oxide (heavy water)	D ₂ O	<i>v</i>	-59.5628		
Hydrogen oxide (heavy water)	D ₂ O	<i>l</i>	-70.4133		
Hydrogen peroxide	H ₂ O ₂	<i>l</i>	-44.84	∞	-0.84
Hydrogen sulfide	H ₂ S	<i>g</i>	-4.815	∞	-4.58
Iron acetate	Fe(C ₂ H ₃ O ₂) ₂	<i>in 1800 H₂O</i>	-353.8		
Iron carbide	Fe ₃ C	<i>c</i>	+5.0		
Iron carbonate	FeCO ₃	<i>c</i>	-178.70		
Iron chloride	FeCl ₂	<i>c</i>	-81.5	∞	-19.5
Iron chloride	FeCl ₃	<i>c</i>	-96.8	∞	-31.1
Iron hydroxide	Fe(OH) ₂	<i>c</i>	-135.8		
Iron hydroxide	Fe(OH) ₃	<i>c</i>	-197.0		
Iron nitride	Fe ₄ N	<i>c</i>	-2.55		
Iron oxide	FeO	<i>c</i>	-64.3		
Iron oxide	Fe _{0.95} O	Wustite, <i>c</i>	-63.7		
Iron oxide	Fe ₂ O ₄	<i>c</i>	-267.0		
Iron oxide	Fe ₂ O ₃	<i>c</i>	-196.5		
Iron silicate	FeO·SiO ₂	<i>c</i>	-276		
Iron silicate	2FeO·SiO ₂	<i>c</i>	-343.7		
Iron sulfate	Fe ₂ (SO ₄) ₃	<i>in 3000 H₂O</i>	-653.62		
Iron sulfate	FeSO ₄	<i>c</i>	-220.5	200	-15.5
Iron sulfide	FeS	<i>c</i>	-22.72		
Iron sulfide	FeS ₂	Pyrites, <i>c</i>	-42.52		
Lead acetate	Pb(C ₂ H ₃ O ₂) ₂	<i>c</i>	-230.5	∞	-2.1
Lead carbonate	PbCO ₃	<i>c</i>	-167.3		
Lead chloride	PbCl ₂	<i>c</i>	-85.85	∞	+6.20
Lead nitrate	PbNO ₃	<i>c</i>	-107.35	∞	+9.00
Lead oxide (yellow)	PbO	<i>c</i>	-52.07		
Lead peroxide	PbO ₂	<i>c</i>	-66.12		
Lead suboxide	Pb ₂ O	<i>c</i>	-51.2		
Lead sesquioxide	Pb ₃ O ₄	<i>c</i>	-175.6		
Lead sulfate	PbSO ₄	<i>c</i>	-219.50		
Lead sulfide	PbS	<i>c</i>	-22.54		
Lithium chloride	LiCl	<i>c</i>	-97.70	∞	-8.877
Lithium hydroxide	LiOH	<i>c</i>	-116.45	∞	-5.061
Magnesium carbonate	MgCO ₃	<i>c</i>	-266		
Magnesium chloride	MgCl ₂	<i>c</i>	-153.40	∞	-37.06
Magnesium hydroxide	Mg(OH) ₂	<i>c</i>	-221.00		
Magnesium oxide	MgO	<i>c</i>	-143.84		
Magnesium silicate	MgSiO ₃	<i>c</i>	-357.9		
Magnesium sulfate	MgSO ₄	<i>c</i>	-305.5	∞	-21.81
Manganese carbonate	MnCO ₃	<i>c</i>	-213.9		
Manganese carbide	Mn ₂ C	<i>c</i>	-1		
Manganese chloride	MnCl ₂	<i>c</i>	-115.3	400	-16.7
Manganese oxide	MnO	<i>c</i>	-92.0		
Manganese oxide	Mn ₂ O ₄	<i>c</i>	-331.4		
Manganese oxide	Mn ₂ O ₃	<i>c</i>	-232.1		
Manganese dioxide	MnO ₂	<i>c</i>	-124.5		
Manganese dioxide	MnO ₂	<i>amorph</i>	-117.0		
Manganese silicate	MnO·SiO ₂	<i>c</i>	-302.5		
Manganese silicate	MnO·SiO ₂	<i>glass</i>	-294.0		
Manganese sulfate	MnSO ₄	<i>c</i>	-254.24	∞	-14.96
Manganese sulfide	MnS	<i>c</i>	-48.8		

Compound	Formula	State	ΔH_f° , Heat of Formation	Moles of Water	ΔH_s° , Heat of Solution
Mercury acetate	Hg(C ₂ H ₃ O ₂) ₂	c	-199.4	∞	+4.2
Mercury bromide	HgBr ₂	c	-40.5	∞	+3.4
Mercury chloride	HgCl ₂	c	-55.0	∞	+3.2
Mercury chloride	Hg ₂ Cl ₂	c	-63.32		
Mercury nitrate	Hg(NO ₃) ₂	dil	-58.0		
Mercury nitrate	Hg ₂ (NO ₃) ₂ ·2H ₂ O	c	-206.9		
Mercury oxide	HgO	red, c	-21.68		
Mercury oxide	HgO	yellow, c	-21.56		
Mercury oxide	Hg ₂ O	c	-21.8		
Mercury sulfate	HgSO ₄	c	-168.3		
Mercury sulfate	Hg ₂ SO ₄	c	-177.34		
Mercury sulfide	HgS	Cinnabar, c	-13.90		
Mercury thiocyanate	Hg(CNS) ₂	c	+48.0		
Molybdenum oxide	MoO ₂	c	-130		
Molybdenum oxide	MoO ₃	c	-180.33	∞	-7.77
Molybdenum sulfide	MoS ₂	c	-55.5		
Nickel chloride	NiCl ₂	c	-75.5	10,000	-19.63
Nickel cyanide	Ni(CN) ₂	c	+27.1		
Nickel hydroxide	Ni(OH) ₂	c	-162.1		
Nickel hydroxide	Ni(OH) ₂	c	-128.6		
Nickel oxide	NiO	c	-58.4		
Nickel sulfide	NiS	c	-17.5		
Nickel sulfate	NiSO ₄	c	-213.0	∞	-19.2
Nitrogen oxide	NO	g	+21.600		
Nitrogen oxide	N ₂ O	g	+19.49		
Nitrogen oxide	NO ₂	g	+8.091		
Nitrogen pentoxide	N ₂ O ₅	g	+3.6	∞	-34.03
Nitrogen pentoxide	N ₂ O ₅	c	-10.0	∞	-20.43
Nitrogen tetroxide	N ₂ O ₄	g	+2.309		
Nitrogen trioxide	N ₂ O ₃	g	+20.0		
Nitric acid	HNO ₃	l	-41.404	∞	-7.968
Oxalic acid	H ₂ C ₂ O ₄ ·2H ₂ O	c	-340.9	2100	+8.70
Oxalic acid	H ₂ C ₂ O ₄	c	-197.6	2100	+2.03
Perchloric acid	HClO ₄	l	-11.1	∞	-20.31
Phosphoric acid (meta)	HPO ₃	c	-223.2	∞	-6.7
Phosphoric acid (ortho)	H ₃ PO ₄	c	-306.2	3000	-3.2
Phosphoric acid (pyro)	H ₄ P ₂ O ₇	c	-538.0	∞	-7.9
Phosphorous acid (hypo)	H ₃ PO ₂	l	-143.2	∞	-2.4
Phosphorous acid (ortho)	H ₃ PO ₃	l	-229.1	∞	-3.1
Phosphorus trichloride	PCl ₃	g	-73.22		
Phosphorus pentoxide	P ₂ O ₅	c	-360.0		
Platinum chloride	PtCl ₄	c	-62.9	∞	-19.5
Platinum chloride	PtCl	c	-17.7		
Potassium acetate	KC ₂ H ₃ O ₂	c	-173.2	∞	-3.68
Potassium carbonate	K ₂ CO ₃	c	-273.93	1000	-7.63
Potassium chlorate	KClO ₃	c	-93.50	∞	+9.96
Potassium chloride	KCl	c	-104.175	∞	+4.115
Potassium chromate	K ₂ CrO ₄	c	-330.49	∞	+4.49
Potassium cyanide	KCN	c	-26.90	∞	+2.80
Potassium dichromate	K ₂ Cr ₂ O ₇	c	-485.90	2000	+17.20
Potassium fluoride	KF	c	-134.46	∞	-4.24
Potassium nitrate	KNO ₃	c	-117.76	∞	+8.35
Potassium oxide	K ₂ O	c	-86.4	∞	-73.28
Potassium sulfate	K ₂ SO ₄	c	-342.66	∞	+5.68
Potassium sulfide	K ₂ S	c	-100	∞	-9.9
Potassium sulfite	K ₂ SO ₃	c	-266.9	∞	-2.2
Potassium thiosulfate	K ₂ S ₂ O ₃	aq	-274		

Compound	Formula	State	ΔH°_f , Heat of Formation	Moles of Water	ΔH°_s , Heat of Solution
Potassium hydroxide	KOH	c	-101.73	∞	-13.22
Potassium nitrate	KNO ₃	c	-117.76	∞	+8.348
Potassium permanganate	KMnO ₄	c	-194.4	4000	+10.5
Selenium oxide	SeO ₂	c	-55.0	∞	+0.93
Silicon carbide	SiC	c	-26.7		
Silicon tetrachloride	SiCl ₄	l	-153.0		
Silicon tetrachloride	SiCl ₄	g	-145.7		
Silicon dioxide	SiO ₂	Quartz, c	-205.4		
Silver bromide	AgBr	c	-23.78		
Silver chloride	AgCl	c	-30.362		
Silver nitrate	AgNO ₃	c	-29.43	∞	+5.37
Silver sulfate	Ag ₂ SO ₄	c	-170.50	∞	+4.50
Silver sulfide	Ag ₂ S	α, c	-7.60		
Sodium acetate	NaC ₂ H ₃ O ₂	c	-169.3	∞	-4.322
Sodium arsenate	Na ₃ AsO ₄	c	-365	500	-16.5
Sodium tetraborate	Na ₂ B ₄ O ₇	c	-777.7	900	-10.2
Sodium borate	Na ₂ B ₄ O ₇ ·10H ₂ O	c	-1497.2	900	+26.1
Sodium bromide	NaBr	c	-86.030	∞	-0.15
Sodium carbonate	Na ₂ CO ₃	c	-270.3	400	-5.6
Sodium carbonate	Na ₂ CO ₃ ·10H ₂ O	c	-975.6	400	+16.5
Sodium bicarbonate	NaHCO ₃	c	-226.5	∞	+4.0
Sodium chlorate	NaClO ₃	c	-85.73	∞	+4.95
Sodium chloride	NaCl	c	-98.232	∞	+0.930
Sodium cyanide	NaCN	c	-21.46	200	+0.26
Sodium fluoride	NaF	c	-136.0	∞	+0.06
Sodium hydroxide	NaOH	c	-101.99	∞	-10.246
Sodium iodide	NaI	c	-68.84	∞	-1.81
Sodium nitrate	NaNO ₃	c	-101.54	∞	-5.111
Sodium oxalate	Na ₂ C ₂ O ₄	c	-314.3	600	+3.8
Sodium oxide	Na ₂ O	c	-99.4	∞	-56.8
Sodium triphosphate	Na ₃ PO ₄	c	-460	1000	-13.9
Sodium diphosphate	Na ₂ HPO ₄	c	-417.4	1000	-6.04
Sodium monophosphate	NaH ₂ PO ₄	in 300 H ₂ O	-367.7		
Sodium phosphite	Na ₂ HPO ₃	c	-338	800	-9.5
Sodium selenate	Na ₂ SeO ₄	c	-258	∞	-1.7
Sodium selenide	Na ₂ Se	c	-63.0	∞	-19.9
Sodium sulfate	Na ₂ SO ₄	c	-330.90	∞	-0.56
Sodium sulfate	Na ₂ SO ₄ ·10H ₂ O	c	-1033.48	∞	+18.85
Sodium bisulfate	NaHSO ₄	c	-269.2	200	-1.4
Sodium sulfide	Na ₂ S	c	-89.2	800	-15.16
Sodium sulfide	Na ₂ S·4½H ₂ O	c	-416.9	800	+5.11
Sodium sulfite	Na ₂ SO ₃	c	-260.6	∞	-3.2
Sodium bisulfite	NaHSO ₃	dil	-206.6		
Sodium silicate	Na ₂ SiO ₃	glass	-360		
Sodium silicofluoride	Na ₂ SiF ₆	c	-677	600	+5.8
Sulfur dioxide	SO ₂	g	-70.96	10,000	9.90
Sulfur trioxide	SO ₃	g	-94.45	∞	-54.13
Sulfuric acid	H ₂ SO ₄	l	-193.91	∞	-22.99
Tellurium oxide	TeO ₂	c	-77.69	∞	+1.31
Tin chloride	SnCl ₄	l	-130.3	aq HCl	-29.9
Tin chloride	SnCl ₂	c	-83.6	aq HCl	-0.4
Tin oxide	SnO ₂	c	-138.8		
Tin oxide	SnO	c	-68.4		
Titanium oxide	TiO ₂	amorph	-207		
Titanium oxide	TiO ₂	Rutile, c	-218.0		
Tungsten oxide	WC ₂	c	-136.3		
Vanadium oxide	V ₂ O ₅	c	-373		
Zinc acetate	Zn(C ₂ H ₃ O ₂) ₂	c	-258.1	800	-9.8
Zinc bromide	ZnBr ₂	c	-78.17	∞	-16.06
Zinc carbonate	ZnCO ₃	c	-194.2		
Zinc chloride	ZnCl ₂	c	-99.40	∞	-17.08
Zinc hydroxide	Zn(OH) ₂	c	-153.5		
Zinc iodide	ZnI ₂	c	-49.98	∞	-13.19
Zinc oxide	ZnO	c	-83.17		
Zinc sulfate	ZnSO ₄	c	-233.88	∞	-19.45
Zinc sulfide	ZnS	c	-48.5		
Zirconium oxide	ZrO ₂	c	-258.2		