UNIVERSITI SAINS MALAYSIA

Peperiksaan Semester Kedua
Sidang Akademik 2004/2005

Mac 2005

EEE 354 – SISTEM KAWALAN DIGIT

Masa : 3 jam

ARAHAN KEPADA CALON:

Sila pastikan bahawa kertas peperiksaan ini mengandungi **SEPULUH (10)** muka surat berserta **Lampiran (2 mukasurat)** bercetak dan **ENAM (6)** soalan sebelum anda memulakan peperiksaan ini.

Jawab **LIMA (5)** soalan.

Agihan markah bagi soalan diberikan disudut sebelah kanan soalan berkenaan.

Jawab semua soalan di dalam Bahasa Malaysia.

...2/-

1. Persamaan kebezaan untuk suatu sistem kawalan diberikan seperti di bawah.
The difference equation for a control system is given below.

$$y(k) - 1.4y(k-1) + 0.59y(k-2) - 0.07y(k-3) = u(k) - 0.2u(k-2)$$

- (a) Lukiskan gambarajah simulasi untuk persamaan kebezaan yang mewakili sistem tersebut.
Draw the simulation diagram for the difference equation that represents the system.

(25%)

- (b) Tentukan fungsi pindah sistem berdasarkan persamaan kebezaan tersebut.
Determine the transfer function of the system based on the difference equation.

(25%)

- (c) Tentukan persamaan keadaan ruang diskret sistem tersebut berdasarkan fungsi pindah dalam (b). (Nyatakan jawapan anda dalam bentuk CCF).
Determine the discrete state space equation of the system based on the transfer function in (b). (Express your answer in CCF form).

(25%)

- (d) Tentukan $y(kT)$ menggunakan kaedah berjukkan untuk 5 sebutan pertama.
Determine $y(kT)$ using sequential method for the first 5 terms.

(25%)

...3/-

2. Suatu sistem kawalan gelung terbuka boleh diwakili oleh gambarajah berikut:
An open-loop control system can be represented by the following diagram:

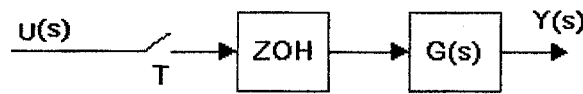

Rajah 1
 Figure 1

Jika
 If

$$G(s) = \frac{2}{(s+2)(2s+1)}$$

- (a) Tentukan fungsi pindah dedenyut sistem tersebut untuk $T = 1s$.
Determine the pulse transfer function of the system for $T = 1s$. (30%)
- (b) Tentukan sambutan masa sistem tersebut bagi masukan unit langkah pada kala pensampelan.
Determine the system time response for a unit step input at the sampling interval. (30%)
- (c) Kirakan sambutan keadaan mantap sistem tersebut menggunakan teorem nilai akhir jelmaan-Z dan juga berdasarkan sambutan masa dalam (b).
Calculate the steady state response of the system using final value theorem of Z-transform and also based on the time domain response in part (b). (30%)
- (d) Apakah sambutan sistem tersebut pada $kT = 10s$?
What is the system response at $kT = 10s$? (10%)

...4/-

3. Rajah 2 mewakili gambarajah blok untuk suatu sistem kawalan.

Figure 2 represents the block diagram of a control system.

- (a) Dapatkan fungsi pindah sistem tersebut, nyatakan $C(z)$ dalam sebutan $R(z)$ dan $U(z)$. Gunakan OFG, SFG dan formula untung Mason dalam terbitan anda.

Obtain the transfer function of the system, express $C(z)$ in term of $R(z)$ and $U(z)$. Use OFG, SFG and Mason's gain formula in your derivation.

(70%)

- (b) Jika fungsi pindah blok-blok tersebut adalah seperti berikut,

If the transfer functions of the blocks are as follows,

$$G_1(s) = \frac{10}{s+5}, \quad G_2(s) = \frac{1}{s+2}, \quad H_1(s) = H_2(s) = 1, \quad D_1(z) = \frac{z}{z-1}$$

dan $D_2(z) = D_3(z) = 1$.

and

Tentukan fungsi pindah sebenar sistem tersebut berdasarkan fungsi pindah yang didapati dalam bahagian (a), untuk $T = 1s$.

Determine the actual transfer function of the system based on the transfer function obtained in part (a), for $T = 1s$.

(30%)

...5/-

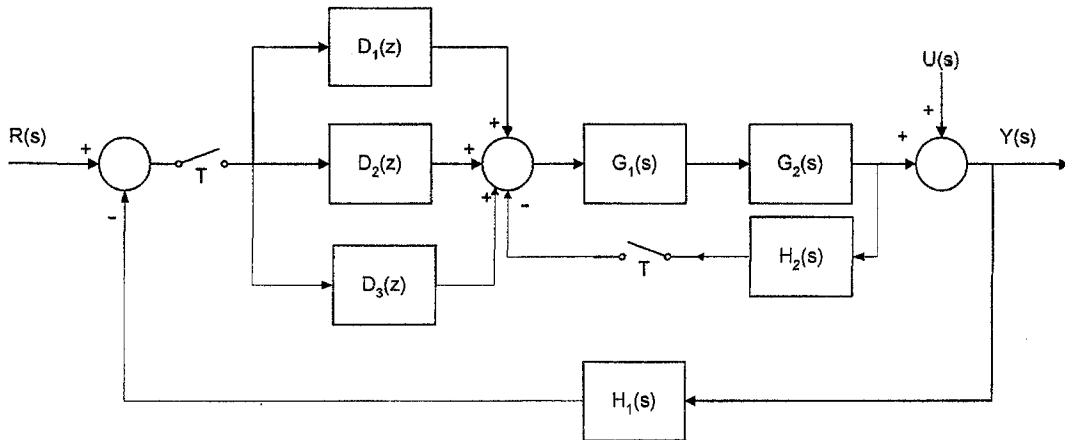

Rajah 2
Figure 2

4. Struktur suatu sistem kawalan suhu boleh dipermudahkan oleh gambarajah blok berikut.

A temperature control system structure can be simplified by the block diagram below.

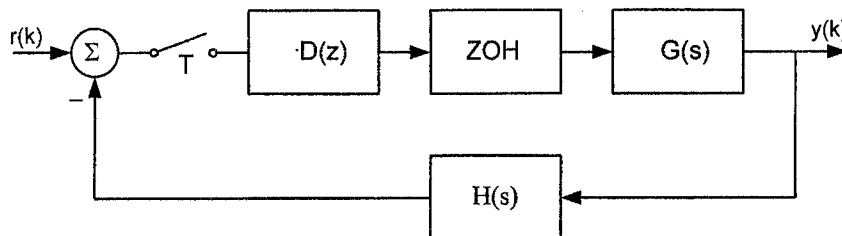

Rajah 3
Figure 3

...6/-

Jika pengawal tersebut disetkan kepada $D(z) = 1$, $H(s) = 1$ dan fungsi pindah dedenyut sistem tersebut ialah:

If the controller is set to $D(z) = 1$, $H(s) = 1$ and the pulse transfer function of the system is:

$$G(z) = \frac{0.207z + 0.191}{z^2 - 1.25z + 0.25}, \quad \text{for } T = 0.1s$$

- (a) Tentukan fungsi pindah gelung tertutup sistem tersebut.
Determine the closed loop transfer function of the system. (10%)
- (b) Berdasarkan persamaan ciri sistem gelung tertutup tersebut, tentukan faktor lemati, frekuensi tabii dan pemalar masa sistem tersebut.
Based on the characteristic equation of the closed loop system, determine the damping factor, natural frequency and time constant of the system. (30%)
- (c) Kirakan ralat keadaan mantap sistem tersebut untuk masukan berikut:
Calculate the steady state error of the system for the following inputs:
- | | | |
|-------|---|-------|
| (i) | Unit langkah
<i>Unit step.</i> | (10%) |
| (ii) | Unit rampa
<i>Unit ramp.</i> | (10%) |
| (iii) | Unit parabola
<i>Unit parabolic.</i> | (10%) |

...7/-

- (d) Ulangi (c) jika $D(z)$ dipilih sebagai pengawal PI iaitu,
Repeat (c) if $D(z)$ is selected to be PI controller that is,

$$D(z) = 2 + \frac{0.1z}{z-1} \quad (30\%)$$

5. Jika fungsi pindah gelung sistem dalam Rajah 3 (rujuk soalan 4) adalah seperti berikut:

If the loop transfer function of the system in Figure 3 (refer to question 4) is as follows:

$$D(z)\overline{GH}(z) = \frac{K(z-0.2)}{z^4 - 1.7z^3 + 0.89z^2 - 0.16z + 0.01}$$

- (a) Tentukan persamaan ciri sistem tersebut dalam sebutan K .
Determine the characteristic equation of the system as a function of K .
 (10%)
- (b) Tentukan julat K supaya sistem tersebut kekal stabil menggunakan ujian kestabilan Jury.
Determine the range of K such that the system will remain stable using Jury's stability test.
 (50%)

...8/-

- (c) Lakarkan gambarajah Nyquist untuk $K = 1$ dalam domain-w bagi fungsi pindah gelung di bawah. Tentukan kestabilan sistem berdasarkan lakaran tersebut. Tandakan sut untung dan sut fasa di atas lakaran tersebut.

Sketch Nyquist plot for $K = 1$ in w -domain for the loop transfer function bellow. Determine the system stability based on the plot. Label the gain and phase margins on the plot.

$$\overline{GH}(z) = \frac{K(z - 0.2)}{(z^2 - 1.4z + 0.53)}$$

(40%)

6. Satu sistem kawalan lengan-robot mempunyai struktur seperti dalam Rajah 3 (rujuk soalan 4). Fungsi pindah dedenyut sistem tersebut ialah:
A control system of a robotic-arm has a structure as in Figure 3 (refer to question 4). The pulse transfer function of the system is:

$$G(z) = \frac{0.0048z + 0.0047}{(z - 1)(z - 0.9048)}, T = 0.1s$$

dan sambutan frekuensi sistem tersebut di tunjukkan dalam Jadual 1.
and the frequency response of the system is shown in Table 1.

- (a) Anggarkan nilai jidar untung dan jidar fasa sistem tersebut berdasarkan sambutan frekuensi dalam Jadual 1.
Estimate gain and phase margins of the system based on the frequency response in Table 1.

(10%)

...9/-

- (b) Rekabentuk satu pengawal susulan fasa unit-untung yang akan meningkatkan jidar fasa kepada kira-kira 60° .

Design a phase lag controller of unity gain that will improve the phase margin to about 60°

(40%)

- (c) Apakah kesan penambahan pengawal susulan fasa terhadap untung keseluruhan sistem? Tentukan untung pengawal tersebut pada keadaan mantap.

What is the effect of adding the phase lag controller to overall gain of the system? Determine the system gain at steady state.

(15%)

- (d) Rekabentuk satu pengawal PID untuk mencapai jidar fasa 60° dengan $K_I = 0.1$. Nyatakan pengawal PID tersebut dalam domain w .

Design a PID controller to gives 60° phase margin with $K_I = 0.1$. Express the PID controller in w -domain.

(35%)

...10/-

Jadual 1
Table 1

ω_s	ω	$ G(j\omega_s) $	$ G(j\omega_s) _{dB}$	$ G(j\omega_s) $	$ G(j\omega_s) _{dB}$	$\left \frac{G(j\omega_s)}{1 + G(j\omega_s)} \right $
0.1000	0.1000	9.95041	19.95682	-95.99702	0.04760	
0.2000	0.2000	4.90299	13.80922	-101.88250	0.18813	
0.3000	0.3000	3.19289	10.08369	-107.55740	0.41372	
0.4000	0.3999	2.32139	7.31496	-112.94450	0.70734	
0.5000	0.4999	1.78911	5.05276	-117.99240	1.03622	
0.6000	0.5998	1.42948	3.10358	-122.67450	1.34277	
0.7000	0.6997	1.17073	1.36911	-126.98560	1.53758	
0.8000	0.7996	0.97655	-0.20612	-130.93550	1.50754	
0.9000	0.8994	0.82641	-1.65609	-134.54460	1.15424	
1.0000	0.9992	0.70770	-3.00307	-137.83850	0.44876	
2.0000	1.9934	0.22457	-12.97286	-159.06920	-10.97265	
3.0000	2.9778	0.10651	-19.45228	-169.96690	-18.49177	
4.0000	3.9479	0.06179	-24.18212	-177.09400	-23.62893	
5.0000	4.8996	0.04040	-27.87273	-182.49680	-27.51491	
6.0000	5.8291	0.02858	-30.87771	-186.95820	-30.62776	
7.0000	6.7335	0.02139	-33.39674	-190.83250	-33.21241	
8.0000	7.6101	0.01669	-35.55328	-194.30040	-35.41178	
9.0000	8.4571	0.01344	-37.42904	-197.46320	-37.31700	
10.0000	9.2730	0.01112	-39.08097	-200.38180	-38.99006	
20.0000	15.7080	0.00353	-49.04776	-221.18530	-49.02468	
30.0000	19.6560	0.00200	-53.97535	-232.97050	-53.96489	
40.0000	22.1430	0.00140	-57.09782	-240.09520	-57.09178	
50.0000	23.8060	0.00108	-59.35686	-244.66820	-59.35286	
60.0000	24.9810	0.00088	-61.12365	-247.74910	-61.12076	
70.0000	25.8500	0.00074	-62.57513	-249.89890	-62.57292	
80.0000	26.5160	0.00065	-63.80777	-251.43480	-63.80599	
90.0000	27.0430	0.00057	-64.87953	-252.54670	-64.57804	
100.0000	27.4680	0.00051	-65.82789	-253.35480	-65.82662	

0000000

Lampiran 1 / Appendix 1

Laplace Transforms and z-transforms of Simple Discrete Time Functions

$F(s)$ is the Laplace transform of $f(t)$, and $F(z)$ is the z-transform of $f(kT)$. Note: $f(t) = 0$ for $t = 0$.

Number	$F(s)$	$f(kT)$	$F(z)$
1		$1, k = 0; 0, k \neq 0$	1
2		$1, k = k_0; 0, k \neq k_0$	z^{-k_0}
3	$\frac{1}{s}$	$1(kT)$	$\frac{z}{z-1}$
4	$\frac{1}{s^2}$	kT	$\frac{Tz}{(z-1)^2}$
5	$\frac{1}{s^3}$	$\frac{1}{2!}(kT)^2$	$\frac{T^2}{2} \frac{z(z+1)}{(z-1)^3}$
6	$\frac{1}{s^4}$	$\frac{1}{3!}(kT)^3$	$\frac{T^3}{6} \frac{z(z^2+4z+1)}{(z-1)^4}$
7	$\frac{1}{s^{m+1}}$	$\lim_{a \rightarrow 0} \frac{(-1)^{m-1}}{(m-1)!} \left(\frac{\partial^{m-1}}{\partial a^{m-1}} e^{-akT} \right)$	$\lim_{a \rightarrow 0} \frac{(-1)^{m-1}}{(m-1)!} \left(\frac{\partial^{m-1}}{\partial a^{m-1}} \frac{z}{z - e^{-aT}} \right)$
8	$\frac{1}{s+a}$	e^{-akT}	$\frac{z}{z - e^{-aT}}$
9	$\frac{1}{(s+a)^2}$	kTe^{-akT}	$\frac{Tze^{-aT}}{(z - e^{-aT})^2}$
10	$\frac{1}{(s+a)^3}$	$\frac{1}{2}(kT)^2 e^{-akT}$	$\frac{T^2}{2} e^{-aT} z \frac{(z + e^{-aT})}{(z - e^{-aT})^3}$
11	$\frac{1}{(s+a)^m}$	$\frac{(-1)^{m-1}}{(m-1)!} \left(\frac{\partial^{m-1}}{\partial a^{m-1}} e^{-akT} \right)$	$\frac{(-1)^{m-1}}{(m-1)!} \left(\frac{\partial^{m-1}}{\partial a^{m-1}} \frac{z}{z - e^{-aT}} \right)$
12	$\frac{a}{s(s+a)}$	$1 - e^{-akT}$	$\frac{z(1 - e^{-aT})}{(z-1)(z - e^{-aT})}$
13	$\frac{a}{s^2(s+a)}$	$\frac{1}{a}(akT - 1 + e^{-akT})$	$\frac{z[(aT - 1 + e^{-aT})z + (1 - e^{-aT} - aTe^{-aT})]}{a(z-1)^2(z - e^{-aT})}$
14	$\frac{b-a}{(s+a)(s+b)}$	$e^{-akT} - e^{-bkT}$	$\frac{(e^{-aT} - e^{-bT})z}{(z - e^{-aT})(z - e^{-bT})}$
15	$\frac{s}{(s+a)^2}$	$(1 - akT)e^{-akT}$	$\frac{z[z - e^{-aT}(1 + aT)]}{(z - e^{-aT})^2}$
16	$\frac{a^2}{s(s+a)^2}$	$1 - e^{-akT}(1 + akT)$	$\frac{z[z(1 - e^{-aT} - aTe^{-aT}) + e^{-2aT} - e^{-aT} + aTe^{-aT}]}{(z-1)(z - e^{-aT})^2}$
17	$\frac{(b-a)s}{(s+a)(s+b)}$	$be^{-bkT} - ae^{-akT}$	$\frac{z[z(b-a) - (be^{-aT} - ae^{-bT})]}{(z - e^{-aT})(z - e^{-bT})}$
18	$\frac{a}{s^2 + a^2}$	$\sin akT$	$\frac{z \sin aT}{z^2 - (2 \cos aT)z + 1}$
19	$\frac{s}{s^2 + a^2}$	$\cos akT$	$\frac{z(z - \cos aT)}{z^2 - (2 \cos aT)z + 1}$
20	$\frac{s+a}{(s+a)^2 + b^2}$	$e^{-akT} \cos bkT$	$\frac{z(z - e^{-aT} \cos bT)}{z^2 - 2e^{-aT}(\cos bT)z + e^{-2aT}}$
21	$\frac{b}{(s+a)^2 + b^2}$	$e^{-akT} \sin bkT$	$\frac{ze^{-aT} \sin bT}{z^2 - 2e^{-aT}(\cos bT)z + e^{-2aT}}$
22	$\frac{a^2 + b^2}{s[(s+a)^2 + b^2]}$	$1 - e^{-akT} \left(\cos bkT + \frac{a}{b} \sin bkT \right)$	$\frac{z(Az + B)}{(z-1)[z^2 - 2e^{-aT}(\cos bT)z + e^{-2aT}]}$ $A = 1 - e^{-aT} \cos bT - \frac{a}{b} e^{-aT} \sin bT$ $B = e^{-2aT} + \frac{a}{b} e^{-aT} \sin bT - e^{-aT} \cos bT$