

**PREDICTING SMOKE EMISSION FROM
PALM OIL MILL USING ARTIFICIAL
NEURAL NETWORKS**

by

AHMAD RAZLAN BIN YUSOFF

**Thesis submitted in fulfillment of the
requirements for the degree
of Master of Science**

November 2002

DEDICATION

to,

My mother, father, fiancée, sister and brothers, friends

ACKNOWLEDGEMENT

Bismillah, Alhamdulillah, through His Blessings and Dignity of Allah s.w.t. and Rasulullah s.a.w., finally the research was completed. The author is deeply grateful to Dr Ishak Hj Abdul Azid of the School of Mechanical Engineering, Universiti Sains Malaysia (USM) for his patience, guidance, invaluable suggestions and supervisions throughout the research.

A special note of thank you also goes to my co-supervisor, Assoc. Prof. Dr Abdul Latif Ahmad, who gives a tremendous help, advises at times and efforts provided to me in completing this project.

A note of appreciation to Universiti Sains Malaysia, for giving me scholarship to pursue my graduate studies. A gratefully acknowledgement is reserved to Yayasan FELDA for the financial support of this research. Also special thank you to United Palm Oil Mill, Nibong Tebal, Pulau Pinang and Kilang Kelapa Sawit Mal Maju, Kubu Gajah, Perak, Malaysia for their cooperation in permitting data collection from their mills.

I would like to address my acknowledgments to all the technicians of the school for their assistances and valuable suggestions in carrying out the research work, especially to En. Said, En. Wan Amri, En. Ashamuddin and En Ali.

The understanding, patience, moral support and cooperation of my mother, Pn Mek Mas, father En. Yusoff and my brothers and sister and my adopted family (Pn Asiah, En Yahaya and Zahrah) are deeply acknowledged. Also thanks goes to my colleagues; Zakri, Owan, Kaloi, Bahar and many other friends for their assistances in completing this research.

TABLE OF CONTENTS

TITLE		i
ACKNOWLEDGEMENTS		ii
TABLE OF CONTENTS		iv
LIST OF TABLES		vii
LIST OF FIGURES		x
LIST OF PLATES		xiii
LIST OF ABBREVIATIONS		xiv
ABSTRAK		xvii
ABSTRACT		xix
Chapter 1	INTRODUCTION	
1.1	Project Background	1
1.2	The Research Objectives and Scopes	6
Chapter 2	SMOKE EMISSION FROM PALM OIL MILL	
2.1	Palm oil processes	7
2.1.1	<i>Boiler Steam Plant Operation</i>	9
2.1.2	<i>Combustion Process</i>	11
2.2	Smoke Emission from Boiler	15
2.2.1	<i>Acts and Regulations</i>	17
2.2.2	<i>Smoke Emission Factors</i>	18
Chapter 3	ARTIFICIAL NEURAL NETWORKS (ANN) IN PREDICTING BOILER EMISION	
3.1	Fundamental of Artificial Neural Networks (ANN)	22
3.2	Structure of Artificial Neural Networks(ANN)	24
3.2.1	<i>Artificial Neural Networks (ANN) Training Algorithms</i>	26
3.2.2	<i>Multiple Linear Feedforward model</i>	27
3.2.3	<i>Back Propagation Algorithm</i>	28
3.2.4	<i>Training Parameters</i>	31
3.3	Critical Review of Published Works in Predicting Boiler Emission	34

Chapter 4	METHODOLOGY	
4.1	Experiment Set-up for Data Collection	39
	4.1.1 <i>Equipment Calibration</i>	42
	4.1.2 <i>Palm Fibre and Shell Weighing</i>	42
	4.1.3 <i>Exhaust Measurement</i>	43
	4.1.4 <i>Pollutants Measurement</i>	44
4.2	Major and Minor Input Variables for Artificial Neural Networks (ANN) Simulation	46
	4.2.1 <i>Correlation Coefficient (CC)</i>	47
	4.2.2 <i>Sensitivity Analysis via Artificial Neural Networks (SAANN)</i>	48
4.3	Parameters Settings of Artificial Neural Networks (ANN)	51
4.4	Multiple Linear Regression (MLR) Model	56
4.5	Optimum Operating Condition Using Genetic Algorithms and Artificial Neural Networks (GAANN)	57
Chapter 5	RESULTS AND DISCUSSION	
5.1	Modelling Boiler Emission for Mill No. 1	59
	5.1.1 <i>Major and Minor Input Variables</i>	59
	5.1.1.a) <i>Correlation Coefficient (CC)</i>	60
	5.1.1.b) <i>Sensitivity Analysis via Artificial Neural Networks (SAANN)</i>	62
	5.1.1.c) <i>Major and Minor Input Variables Selection</i>	65
	5.1.2 <i>Data Segmentation</i>	67
	5.1.3 <i>Multiple Linear Regression (MLR) Model</i>	68
	5.1.4 <i>Artificial Neural Networks (ANN) Model</i>	70
	5.1.4.a) <i>Optimization of Structure and Parameters</i>	73
	5.1.4.b) <i>Simulation Results with Single Output Models</i>	73
	5.1.4.c) <i>Simulation Results with Multiple Output Models</i>	77
	5.1.4.d) <i>Comparison Results between Single and Multiple Model</i>	80
	5.1.5 <i>Comparison Results between the Artificial Neural Networks (ANN) and Multiple Linear Regression (MLR) Model</i>	81
5.2	Optimal Operating Condition against Pollution by Using Genetic Algorithms and Artificial Neural Networks (GAANN) for Mill No. 1	84
	5.2.1 <i>Determination of Optimum Process by Using Genetic Algorithms and Artificial Neural Networks (GAANN)</i>	84
	5.2.2 <i>Optimal Operating Condition</i>	85
5.3	Modelling Boiler Emission for Mill No. 2	94
	5.3.1 <i>Major and Minor Input Variables</i>	95
	5.3.2 <i>Data Segmentation</i>	98
	5.3.3 <i>Multiple Linear Regression (MLR) Model</i>	98
	5.3.4 <i>Artificial Neural Networks (ANN) Model</i>	99
	5.3.5 <i>Comparison Results between the Artificial Neural Networks (ANN) and Multiple Linear Regression (MLR) Model</i>	107
5.4	Optimal Operating Condition against Pollution by Using Genetic Algorithms and Artificial Neural Networks (GAANN)	

	for Mill No. 2	107
5.5	Comparison Studies between Mill No. 1 and Mill No. 2	114
Chapter 6	CONCLUSIONS AND SUGGESTIONS FOR FUTURE WORK	
6.1	Conclusions for Current Work	116
6.2	Suggestion for Future Work	117
REFERENCES		119
APPENDICES		128
APPENDIX A	Determination of Calorific Value by Using Bomb Calorimeter	129
APPENIDX B	Pollutant Measurement Procedures	131
APPENDIX C	Licensing Issues for GA	135
APPENDIX D	Data Collections	138
APPENDIX E	Multiple Linear Regression Calculations	143

LIST OF TABLES

Table 1.1	The effects of air pollution to human and the environment	4
Table 2.1	Ultimate Analysis of the selected biomass	12
Table 2.2	Comparison of calorific value of palm waste material	13
Table 2.3	Standardization of exhaust/chimney separation	18
Table 3.1	Different types of input and output variables used in Predictive Emission Monitoring	35
Table 4.1	Boiler specification used at side	41
Table 4.2	Relationship and determination of Correlation Coefficient	48
Table 4.3	Typical Artificial Neural Networks setup for CO model of sensitivity analysis	51
Table 4.4	Typical Artificial Neural Networks setup for CO model of boiler emission model	53
Table 5.1	Correlation Coefficient between input and output variables for mill No. 1	61
Table 5.2	Sensitivity analysis and their ranking of input variables contribution to the emission for mill No. 1	66
Table 5.3	Major factors contribution to the emission released for mill No. 1	67
Table 5.4	Regression analysis of Multiple Linear Regression for mill No. 1	70
Table 5.5	Regression analysis of single models for mill No. 1	74
Table 5.6	Regression analysis of multiple outputs model of mill No. 1	77
Table 5.7	Parametric study effects on Genetic Algorithms and Artificial Neural Networks output	87
Table 5.8	Genetic Algorithms and Artificial Neural Networks output optimization of CO emission for mill No. 1	91

Table 5.9	Genetic Algorithms and Artificial Neural Networks output optimization of NO _x emission for mill No. 1	92
Table 5.10	Genetic Algorithms and Artificial Neural Networks output optimization of PM pollutant for mill No. 1	93
Table 5.11	Genetic Algorithms and Artificial Neural Networks output optimization of SO ₂ pollutant for mill No. 1	93
Table 5.12	Correlation Coefficient (CC) between input variables and output variables of mill No. 2	96
Table 5.13	Sensitivity Analysis with Artificial Neural Networks for the data collection of mill No. 2	97
Table 5.14	Genetic Algorithms and Artificial Neural Networks output optimization of CO emission for mill No. 2	113
Table 5.15	Genetic Algorithms and Artificial Neural Networks output optimization of NO _x emission for mill No. 2	113
Table 5.16	Genetic Algorithms and Artificial Neural Networks output optimization of SO ₂ production for mill No. 2	113
Table 5.17	Genetic Algorithms and Artificial Neural Networks output optimization of PM production for mill No. 2	113
Table D.1	Raw plant data from the experiment of mill No. 1	139
Table D.2	Raw plant data from the experiment of mill No. 2	141
Table E.1	Multiple Linear Regression Calculations for CO using all input variables for mill No. 1	144
Table E.2	Multiple Linear Regression Calculations for NO _x using all input variables for mill No. 1	145
Table E.3	Multiple Linear Regression Calculations for SO ₂ using all input variables for mill No. 1	146
Table E.4	Multiple Linear Regression Calculations for PM using all input variables for mill No. 1	147
Table E.5	Multiple Linear Regression Calculations for CO using major input variables for mill No. 1	148
Table E.6	Multiple Linear Regression Calculations for NO _x using major input variables for mill No. 1	149

Table E.7	Multiple Linear Regression Calculations for SO ₂ using major input variables for mill No. 1	150
Table E.8	Multiple Linear Regression Calculations for PM using major input variables for mill No. 1	151
Table E.9	Multiple Linear Regression Calculations for CO using all input variables for mill No. 2	152
Table E.10	Multiple Linear Regression Calculations for NO _x using all input variables for mill No. 2	153
Table E.11	Multiple Linear Regression Calculations for SO ₂ using all input variables for mill No. 2	154
Table E.12	Multiple Linear Regression Calculations for PM using all input variables for mill No. 2	155

LIST OF FIGURES

Figure 1.1	World producers of palm oil in year 2000	2
Figure 1.2	Air pollution sources in year 1996	2
Figure 2.1	Cross-sectional of a palm fruit	8
Figure 2.2	Palm oil mill steam plant	10
Figure 2.3	Steam distribution to the factory processes	11
Figure 2.4	Schematic diagram showing processes in palm oil mill	16
Figure 2.5	A sample of Ringelmann Smoke Chart	17
Figure 2.6	Input and output parameters for a typical boiler emission	21
Figure 3.1	A simplified model of a biological neuron	23
Figure 3.2	A simplified model of an artificial neuron	24
Figure 3.3	Artificial Neural Networks structure design	26
Figure 3.4	A fully connected of feedforward Artificial Neural Networks (ANN) with one hidden layer	28
Figure 3.5	Back Propagation algorithm Artificial Neural Networks	29
Figure 4.1	Locations for data collection	40
Figure 4.2	Selected input variables for fuel, exhaust, turbine and boiler parameters	40
Figure 4.3	Conveyer movement to carry fibre and shell (fuel) to boiler furnace	43
Figure 4.4	Sensitivity analysis process flowchart using Artificial Neural Networks (ANN)	52
Figure 4.5	Modelling boiler emission process flowchart using Artificial Neural Networks	54
Figure 5.1	Number of hidden neurons for CO model	62

Figure 5.2	Optimum Artificial Neural Networks structure of CO model [15,27,1]	63
Figure 5.3	Number of hidden neurons for multiple model	64
Figure 5.4	Optimum Artificial Neural Networks structure of multiple model [15,27,1]	64
Figure 5.5	Comparison between actual and Multiple Linear Regression for mill No. 1	71
Figure 5.6	Comparison between actual and single model of Artificial Neural Networks for mill No. 1	75
Figure 5.7	Comparison between actual and multiple model of Artificial Neural Networks for mill No. 1	78
Figure 5.8	Comparison between actual, Multiple Linear Regression and Artificial Neural Networks model for mill No. 1	82
Figure 5.9	Crossover rates effect on Genetic Algorithms and Artificial Neural Networks performance	86
Figure 5.10	Mutation rates effect on Genetic Algorithms and Artificial Neural Networks performance	86
Figure 5.11	Population size effect on Genetic Algorithms and Artificial Neural Networks performance	87
Figure 5.12	The release and limitation of CO during data collection for mill No. 1	88
Figure 5.13	The release and limitation of NO _x during data collection for mill No. 1	89
Figure 5.14	The release and limitation of PM during data collection for mill No. 1	89
Figure 5.15	The release of SO ₂ during data collection for mill No. 1	90
Figure 5.16	Comparison between actual and Multiple Linear Regression for mill No. 2	100
Figure 5.17	Comparison between actual and single model of Artificial Neural Networks for mill No. 2	102
Figure 5.18	Comparison between actual and multiple model of Artificial Neural Networks for mill No. 2	105

Figure 5.19	Comparison between actual, Multiple Linear Regression and Artificial Neural Networks model for mill No. 2	108
Figure 5.20	The release and limitation of CO during data collection for mill No. 2	110
Figure 5.21	The release and limitation of NO _x during data collection for mill No. 2	111
Figure 5.22	The release of PM during data collection for mill No. 2	111
Figure 5.23	The release of SO ₂ during data collection for mill No. 2	112
Figure B.1	Method 5 Isokinetic Sources detail device	134
Figure B.2	Traverse points at stack gas cross sectional	134

LIST OF PLATES

Plate 4.1	Typical boiler control panel display	42
Plate 4.2	Stack gas to emit smoke	45
Plate 4.3	Gas analyzer type MSI compact	45
Plate 4.4	Particle source sampling system	46

RAMALAN PELEPASAN ASAP DARI KILANG KELAPA SAWIT MENGUNAKAN RANGKAIAN NEURAL BUATAN

ABSTRAK

Malaysia mengeluarkan 50 % daripada jumlah kuantiti pengeluaran minyak sawit di dunia dan menjadikan negara ini pengeluaran terbesar di dunia. Minyak sawit dihasilkan di kilang-kilang kelapa sawit yang mempunyai loji kuasa stim tersendiri dan loji-loji ini menggunakan bahan buangan kelapa sawit (sabut dan tempurung) sebagai bahaapi dandang. Walaubagaimanapun, hasil-hasil pembakaran menyebabkan pencemaran ke atmosfera yang serius. Berdasarkan kajian pada tahun 1999, hanya 76 % daripada kilang kelapa sawit di Malaysia mematuhi peraturan pelepasan asap *Department of Environmental* (DOE). Pelepasan asap melalui serobong boleh dipantau dengan memodelkan proses masukan (dalam bahan api, turbin, dandang) dan keluaran pencemar. Pemodelan asap dari dandang kilang kelapa sawit berdasarkan Rangkaian Neural Buatan (ANN) digunakan dalam kajian ini. Data dikumpulkan dari dua buah kilang. Regresi Lelurus Pelbagai (MLR) juga digunakan untuk mencari pekali unsur yang menyumbang kepada pelepasan setiap pencemar. Pekali Korelasi (CC) dan Analisis Sensitif Rangkaian Neural Buatan (SAANN) digunakan untuk mencari pembolehubah masukan major dan minor. Keputusan menunjukkan pembolehubah major and minor untuk kedua-dua kilang adalah sama. Ramalan dibuatkan oleh ANN dan MLR menunjukkan keputusan yang hampir sama dengan nilai sebenar yang dikumpulkan dari kedua-dua buah kilang. Namun begitu, ralat untuk MLR (5 %) lebih tinggi daripada ralat yang diperolehi daripada ANN (2.5 %) disebabkan oleh keanjalan dan kebolehan ANN lebih tinggi daripada MLR dalam meramalkan pencemaran yang

merupakan proses yang sangat kompleks dan tidak lurus. Seterusnya, Algoritma Genetik Rangkaian Neural Buatan (GAANN) digunakan untuk mencari keadaan operasi optimum dandang terhadap pelepasan pencemaran yang melebihi had yang dibenarkan. Titik-titik yang melebihi had pencemaran seperti untuk CO, hadnya adalah 870 ppm dioptimumkan supaya pelepasan pencemaran berada di bawah had yang dibenarkan. GAANN telah berjaya mencari gabungan nilai-nilai pembolehubah masukan yang melepaskan asap dalam lingkungan had dibenarkan boleh ditentukan. Walaubagaimanapun, proses pengoptimuman ini tidak ditentusahkan di loji. Penentusah boleh dilakukan di kilang dengan melihat buku rekod loji. Dengan menggunakan kaedah di atas, pemantauan dan pemodelan pencemaran mana-mana loji dapat dilakukan dan proses yang terlibat juga dapat dioptimumkan.

ABSTRACT

Malaysia produces 50 % of the total quantity of palm oil produced in the world and this makes it the largest palm oil producer in the world. Palm oil is produced in palm oil mills, which have their captive steam power plants and these plants use palm oil waste (shell and fibre) as fuel for the boilers. Unfortunately, the combustion products of these materials cause severe atmospheric pollutions. According to a survey in 1999, only 76 % of the palm oil mills in Malaysia meet the regulation of Department of Environment (DOE) regarding the emission. The emission released through the chimney can be monitored by modeling its process of input (in fuel, turbine, boiler) and output of the pollutants. Modeling the emission from the palm oil mill boiler based on Artificial Neural Networks (ANN) is used in this research. The data are collected from two mills. Multiple Linear Regression (MLR) is also applied to find the coefficient of the contributing element to the pollution. Correlation Coefficient (CC) and Sensitivity Analysis via Artificial Neural Networks (SAANN) are applied to find the major and minor input variables to each pollutant. The result shows that the major and minor input variables for both mills are similar. The prediction made by ANN and MLR agrees well with the actual values collected from both mills. However, the error for MLR (5 %) is slightly higher than the error obtained for ANN (2.5 %) as the flexibility and capability of ANN is more than MLR in predicting emission which is very complex and non-linear process. After that, Genetic Algorithms and Artificial Neural Networks (GAANN) is

applied to find the optimal operating condition of the boiler against pollution released. The points which exceed the allowable limit of pollution such as for CO, the limit is 870 ppm are optimized so that the pollution released is within the allowable limit. GAANN succeeded in finding the combination of values for input variables which release allowable emission level. However, this optimization process has not been verified yet in the plant. It could be actually tried out in the plant by looking at the log book of the plants. By using the above approaches, monitoring and modeling pollution from any plant can be utilized and the process involved can also be optimized.

Chapter 1

INTRODUCTION

1.1 Project Background

Palm oil contributes to 19 % of worldwide vegetable oil production. This is primarily due to its high oil output per hectare (6 tons of oil per hectare) and plantation rate compared to other commercial crops such as soya bean, sunflower and coconut. Figure 1.1 shows the world producers of palm oil in the year 2000. It shows that Malaysia produces 7.22 million tonne, which is 50.0 % of the world supply making it the largest producer in the world (Oil, 2000). In year the 2000, Malaysia exported 95 % of the 9 million tonne of oil refinery and fractional products. Palm oil and its related product contributes about 7 to 8 % of Gross Net Production (GNP) of Malaysia which corresponds to the second largest foreign exchange, next earnings only to petroleum and gas industries. The production of palm oil demand is proportionate to the world population growth which is around 1.6 % per year while the world palm oil production growth is around 7.3 % per year. In the year 2010, it is predicted that crude palm oil (CPO) production will reach 10.5 million tonne, which is 64 times increment in comparison to other industries (Laporan, 1998). While the palm oil industry is a major foreign exchange earner, it is also a source of pollution.

Environmental quality report as shown in Figure 1.2 gives the amount in percentage of pollution sources in Malaysia that contributes to the haze phenomena (Laporan, 1998). Out of this pollution source, power plants contribute 9 % to the pollution. The power plants use sources from fossil such as petroleum, coal, and natural

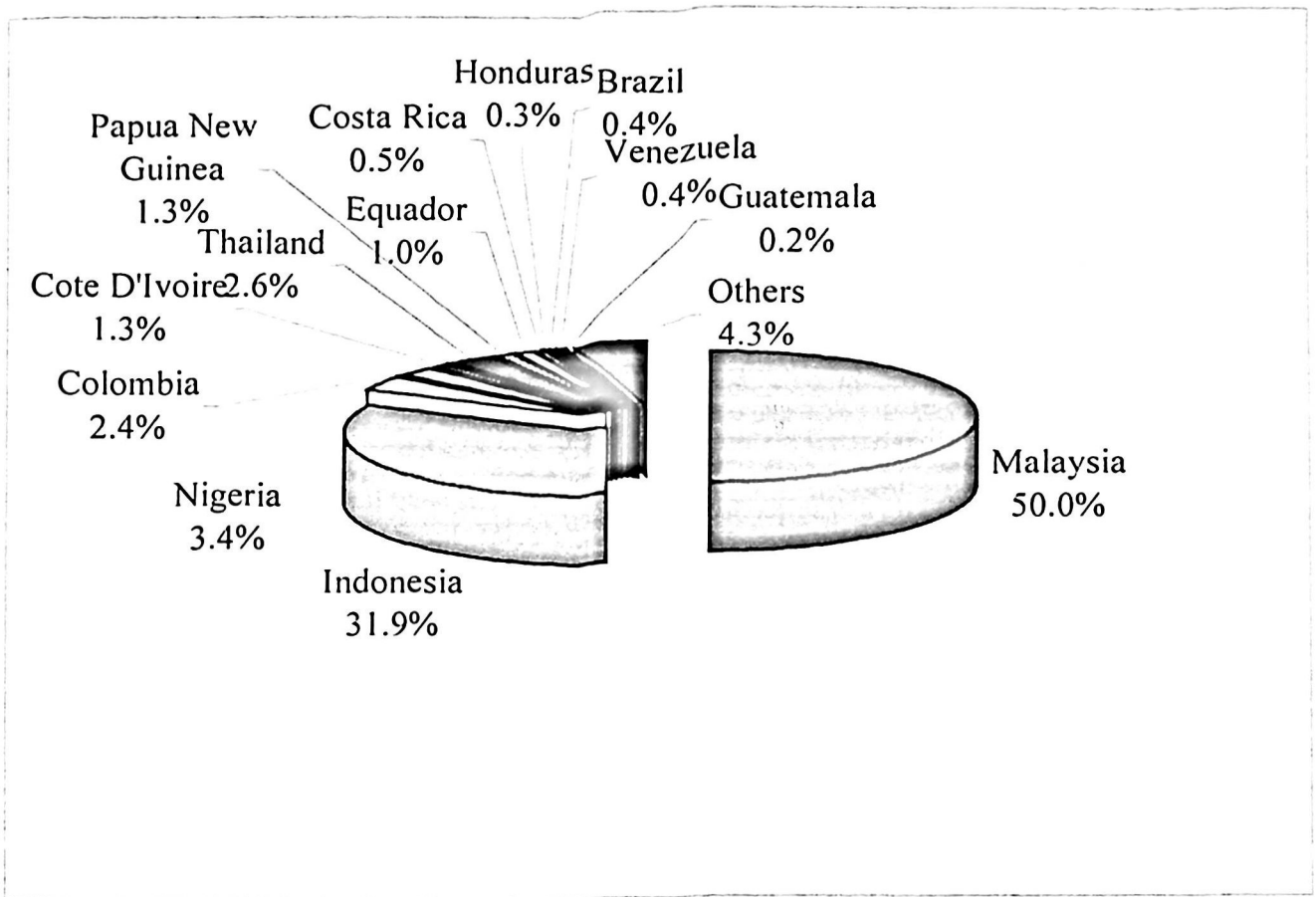

Figure 1.1 World producers of palm oil in year 2000 (Oil World Annual, 2000)

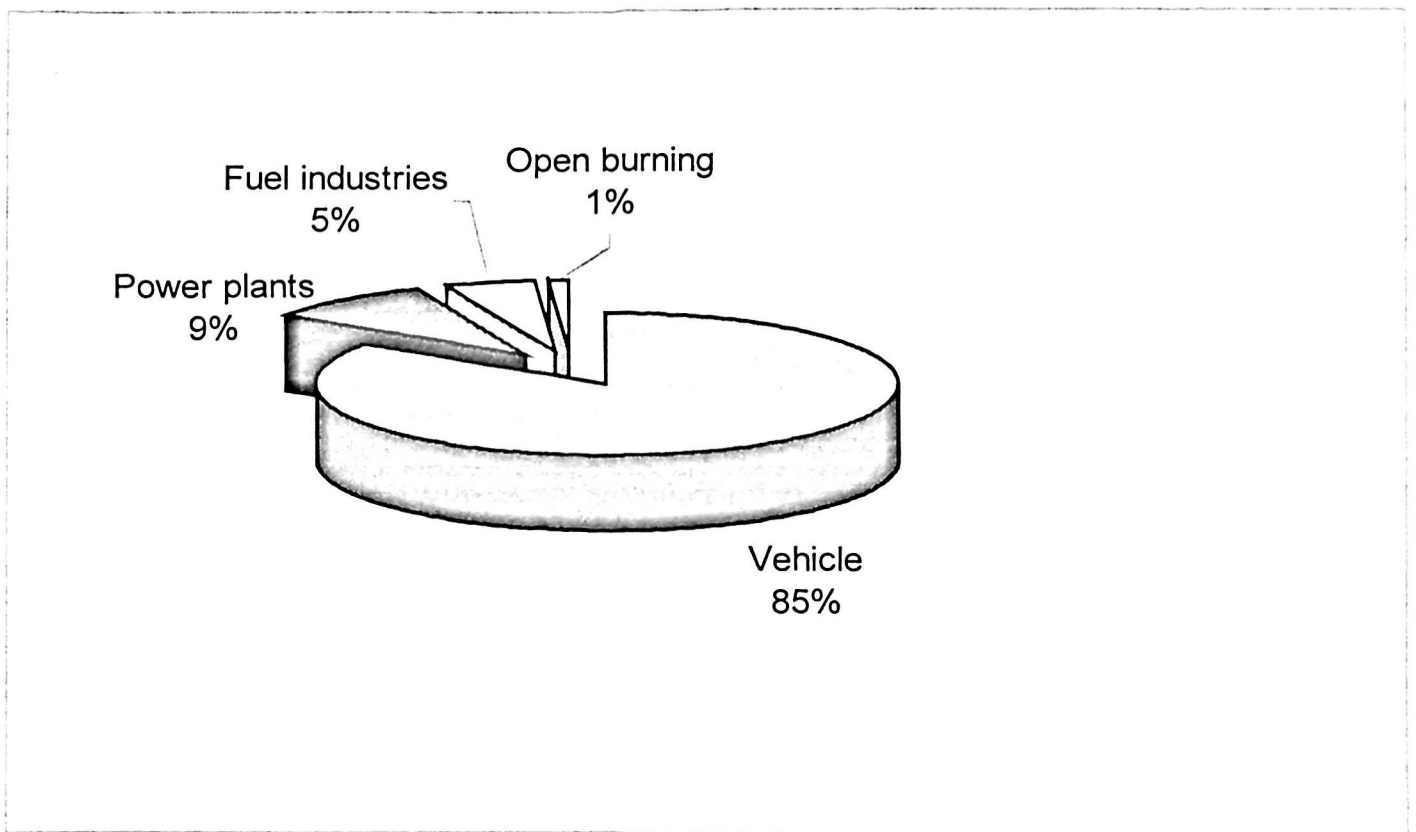

Figure 1.2 Air pollution sources in year 1996 (Laporan Kualiti Alam Sekitar, 1998)

gas as well as renewable energy such as hydro and biomass to generate mostly electricity. At present, the electrical energy generated from palm oil mills, rubber estates and other private bodies exceeds a capacity of over 6000 MW. It is estimated that these power plants account for 1-2 % of total energy produced in the country. Currently, Malaysian government targets that 5 % of total electric generation come from the renewable energy. The huge technical potential for biomass residue from palm oil and wood is estimated to be around RM200 billion for a period of 20 years (2001-2020). Unfortunately, these palm oil mills and rubber industries are also recognised to be one of the major sources of air pollution. Department of Environment (DOE) reported a satisfactory level of adherence to Environmental Quality Regulations (clean air) 1978 for most industries except the palm oil and rubber industries which are identified as major contributors to country's air pollution. Only 76 % of the 309 palm oil mills in operation met the DOE regulation (Berita Harian, 1999). This requires DOE to act by strictly withdrawing and containing the operation licences of those mills that ignored the rules regarding atmospheric pollution. Smoke and fumes released by such palm oil mills are usually visible from far away distances from the mills. The utilization of palm waste materials like fibre and shell as fuel is the main factor contributing to the emission of pollutants.

According to Leong (1986), for every 1 tonne of fresh fruit bunch (FFB), it produces 1.5 g/Nm^3 of particulate matter (PM). Hence, for a typical 500 000 tonnes of CPO, it may require the burning of 17 500 000 tonnes of FFB. This may result in the production of pollutant of 1 to 1.5 tonnes particulate matter to atmosphere per mill. The total amount of particles emitted by 309 palm oil mills in Malaysia is then about 154 500 tonnes in a day. Over an extended period of time, this level of pollution will certainly threaten the lives of human, animals, plants and buildings. Black smoke from

palm oil mill contains various pollutant gasses and materials such as nitrogen dioxide (NO_x), carbon monoxide (CO), particulate matter (PM) and sulphur dioxide (SO₂) which give various having effect to humans and environment as indicated in Table 1.1 (Leong, 1986; Krishnan, 1990). Other side effects of black smoke include the interruption of air and sea transportation and traffic services. Air pollution also indirectly brings bad effects to the economy. It tends to raise the expenditure for health care and increases the cost needed to cover the work lost due to illness, damage to agricultural crops, buildings, paint *etc.* Furthermore, air pollution also affects the tourism industry and this is bad to the country's economy.

Table 1.1 The effects of air pollution to human and the environmental

Pollutants	Effects to human and the environment
NO _x	Damages ozone layer and ultra violet filters thereby causing cancer and skin diseases. Damages the human respiratory system and causes headache when exposed to high concentrations. Animals will be affected by smog and acid rain produced.
CO	The combination of haemoglobin and CO produce carboxy haemoglobin that causes low blood ability to carry oxygen in our blood circular system. The effect from this phenomenon causes fatigue, flu and headache. Other chronic diseases that will affect to human cardiovascular, brain damage, artery system, breath system and heart. Fatal of animal occurred due to high exposure to it.
Particulate matter (PM)	The PM will penetrate our respiratory system and causes heart attack, asthma, lung cancer, cardio pulmonary diseases and pneumonia. The effects to plant are hesitation of their growth system, bleaching of the leaves colour and damage to plant tissue. It also causes visual pollution, damage and dirt on the building.
SO ₂	Acid rain forming from this gas damages the breathing system of crops. Our respiratory system will also be affected, as it will damage the pulmonary system leading to cardiovascular diseases.

Air pollution can never be totally eliminated. However, it can be minimized by controlled method (Lynn, 1976). Most of the palm oil mills have installed smoke density sensors which monitor the smoke production in units of opacity. Opacity is the

degree of smoke that reduces the passage of light as determined by a certified observer. It is expressed numerically from 0 % (fully transparent) to 100 % (fully opaque). In Malaysia only industries that use process combustion such as power plants and palm oil mills are required to install smoke density sensor meter in order to comply with the ISO 1400 standard. On top of that, most power plants install a new system called Continuous Emission Monitoring system (CEMs) which monitors the pollution level released 'online'. The CEMs is better than smoke density as it can give the smoke composition and production level automatically. Palm oil mills however are not required and expected to install this system due to the high maintenance cost (US\$10 000 per year) and its expensive initial installation cost (US\$ 200 000).

Monitoring emission based on a Artificial Neural Networks (ANN) model is proposed in the current study. The proposed model can be classified as a part of a Predictive Emission Monitoring system (PEMs) that operates in the same function as Continuous Emission Monitoring system (CEMs) in terms of monitoring several types of pollutants from various processes. Its main advantage is that it is cheaper than CEMs in operation and maintenance. This current study discusses the possibilities and suitability of a ANN in predicting and monitoring the smoke emission from biomass steam power plant at palm oil mill. Multiple Linear Regression (MLR) is also applied to search the coefficient of the contributing element to the pollution. ANN is then combined with Genetic Algorithms (GA) to seek the optimal operating condition by minimizing the pollution produced without reducing the power generated.

1.2 The Research Objectives

The main objective of the project is to develop a boiler emission model in order to predict the smoke emission using Artificial Neural Networks (ANN). This research attempts to achieve the following objectives:

1. To filter the emission factors from the data collected from palm oil mill.
2. To model the boiler emission relationship using ANN programme.
3. To find the correlation of the contributing elements to pollution by using MLR.
4. To obtain complete data of the boiler emission.
5. To optimize the operating conditions with a reduction in pollution by using GA and ANN.

Chapter 2

SMOKE EMISSION FROM PALM OIL MILL

In this chapter, the discussion is focused on the factors that cause boiler emission and pollutants. The processes in the palm oil mill which generate electricity as a by-product from fibre and shell combustion as well as smoke emission from the steam power plant are explained. In this chapter, palm oil process and smoke emission from boiler are discussed.

2.1 Palm Oil Processes

The oil palm, *Elaeis guineensis*, which is originated from West Africa, was introduced to Malaysia in 1870 as an ornamental plant. Its use as a crop was not developed until 1917, when it was grown commercially. Figure 2.1 shows the botanical structure of a palm nut. The structure consists of three layers. The centre of the fruit is the kernel which is covered by shell and the outer surface is covered by fibre. In order to process the fresh fruit bunch (FFB), a palm oil mill must be situated beside or close to the palm estates as the fruit can rot easily. A tonne of FFB consists of 15 % fibre, 7 % shell and 21 % effluent fresh bunch (EFB) producing around 14-21 % crude palm oil (CPO). Palm oil is mainly used in food industry (cooking oil, margarine, shortening, *etc*) as well as non-food applications (soap, detergent, cosmetics, *etc*). Several processes are carried out to deliver final products. The initial step of the process takes place in the mill where the CPO is extracted from the FFB. Various operations are carried out in

these processes which include loading, sterilization, threshing and crushing, digesting, pressing, depericarper, kernel production and clarification.

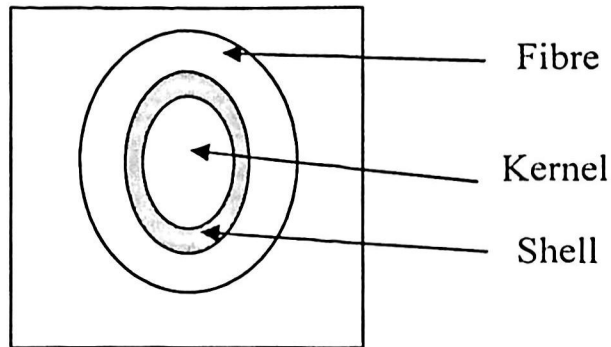

Figure 2.1 Cross-sectional of a palm fruit

Loading process carries FFB in trolley in order to maintain a constant FFB weight throughout the processes. During sterilization, the FFB will be heated to ease detachment of fruits from bunches and to soften them for the pressing processes. The sterilizer uses saturated steam at 3 bar pressure and a temperature of 140°C for 90 minutes. The FFB are threshed during the threshing process by using rotating threshing drum. The first process of extracting oil from fibre and shell begins when high-pressure skew presser does pressing after FFB is heated with steam from the boiler. The CPO contains palm oil (35-45 %), water (45-55 %) and fibre material which are sent to the clarification process. In the clarification process, the CPO is kept at the temperature of 90°C and a high velocity centrifugal and vacuum dryer is used to obtain high class oil before storing it in a saving tank.

During the pressing process, winnowing suction process separates the fibre and nut (containing kernel and shell). The kernel and shell are separated in a process called cake cracking which is done by pneumatic separation. Then the nut is processed at kernel production station. The dry kernel is saved in the bulk silo, while the shells are carried together with fibre to be used as a fuel in the furnace to heat up the boiler. In

this work, the processes of interest are related to the boiler and combustion and these are discussed in the following pages.

2.1.1 *Boiler Steam Plant Operation*

The steam under high pressure produced by boiler can be used for heating, processing and power generation. In palm oil boiler steam plant, the steam is generated from the heated water from the combustion of fibre and shell fuels to drive the turbine. There are two types of boilers normally used for producing steam; water tube boiler and fire tube boiler. A fire tube boiler uses hot gas which flows inside the tubes and water is surrounding the tubes, while water tube boiler uses water which passes through tubes and hot gases surrounding them. Water tube boiler is commonly used because of its greater safety, faster steam generation, suitability for use in power plants and occupied less area than fire tube boiler. Water in metal tubes is used as a medium to transfer the heat energy through process of convection and radiation. Figure 2.2 shows the palm oil steam plant with the devices, the processes flow and steam distribution.

Most of steam plant palm oil mills use natural circulation. In the natural circulation, a simple principle of variation of water and steam-water density mixture is used. There are many parallel riser circuits to carry the steam water mixture and a few larger cold downcomers to carry water. The raw water is first to be treated by using softener and deaerator to remove O_2 and CO_2 gas before entering the boiler drum to overcome the tube bursting. After that, the water is heated at certain temperature using the inlet heater. Water is then pumped into the boiler drum at high temperature and pressure. The generated steam is then sent to the super heater to obtain high temperature and high-pressure steam condition (Li & Priddy, 1985). The steam turbine uses steam to rotate the alternator for producing power electricity. After that, the steam

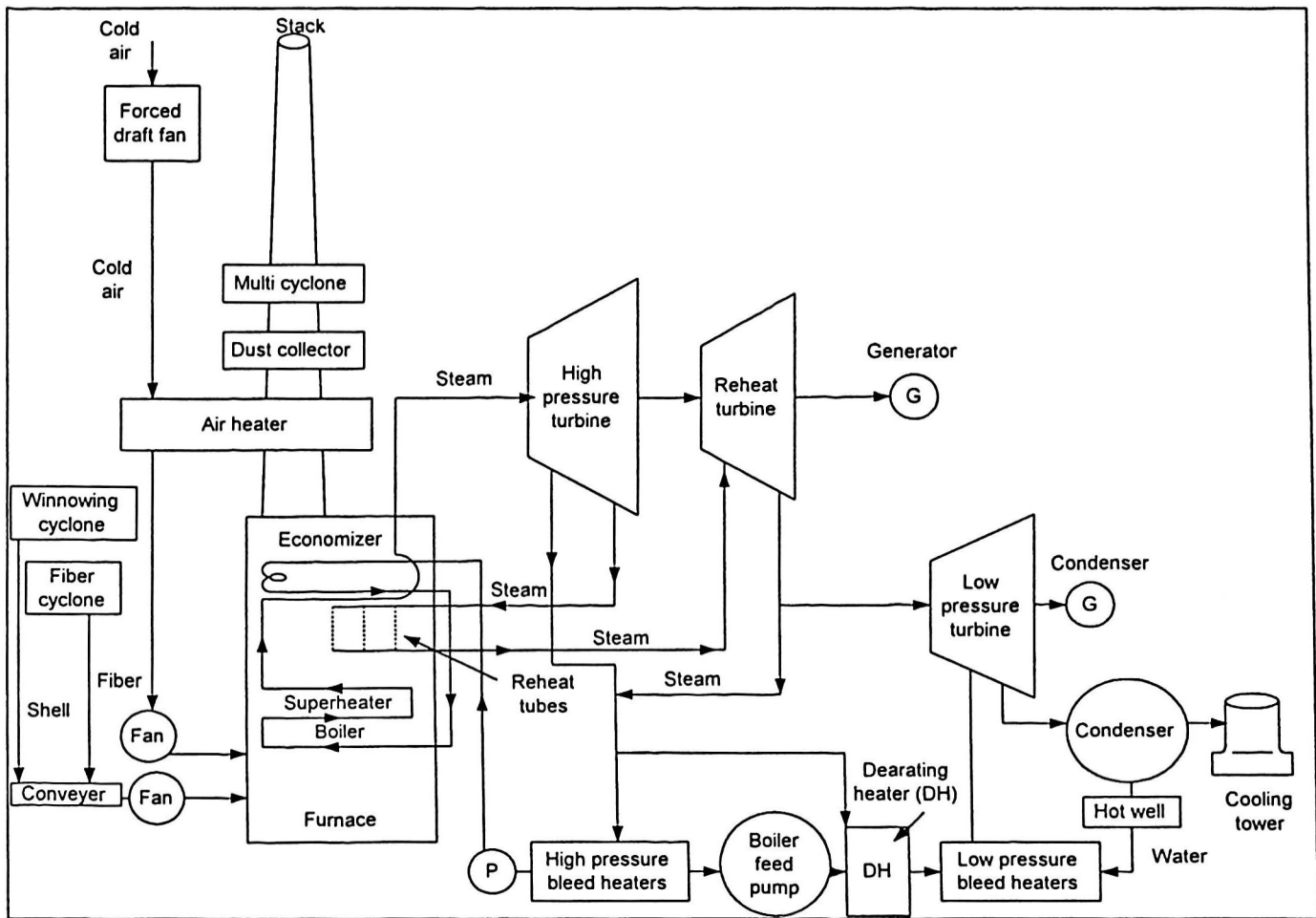

Figure 2.2 Palm oil mill steam plant (Weisman & Eckart, 1985)

is distributed for other purposes in palm oil processes. The regenerated steam is added to protect the falling of temperature and pressure that would damage the turbine. The water that does not change into steam will be sent to the sludge drum from boiler drum. The blow down process is used to clean the drum from the sludge.

Li & Priddy (1985) reported that the accessories equipment such as a super heater, reheating system, regenerating system, pre-heating and the economiser help to increase the steam plant efficiency (refer to Figure 2.2). The purpose of super heater is to increase steam temperature, which produces drier and higher steam temperature to increase turbine efficiency. The reheated system is used to stabilize the high steam temperature production in order to have low-pressure steam when entering the turbine. The regenerating system is used to increase the inlet water superheated temperature level before it enters the boiler. On the other hand, the pre-heat accessory will heat the

air that is required to combust the fuel to increase combustion temperature and heat the inlet water to accommodate steam generation. The steam coming from the turbine is distributed as shown in Figure 2.3. When high pressure condition occurs at back pressure receiver distributor, the steam will be removed and distributed to the sterilizer, digester, crude oil tank, clarification, oil storage tank and kernel dryer which requires hot water in their processes.

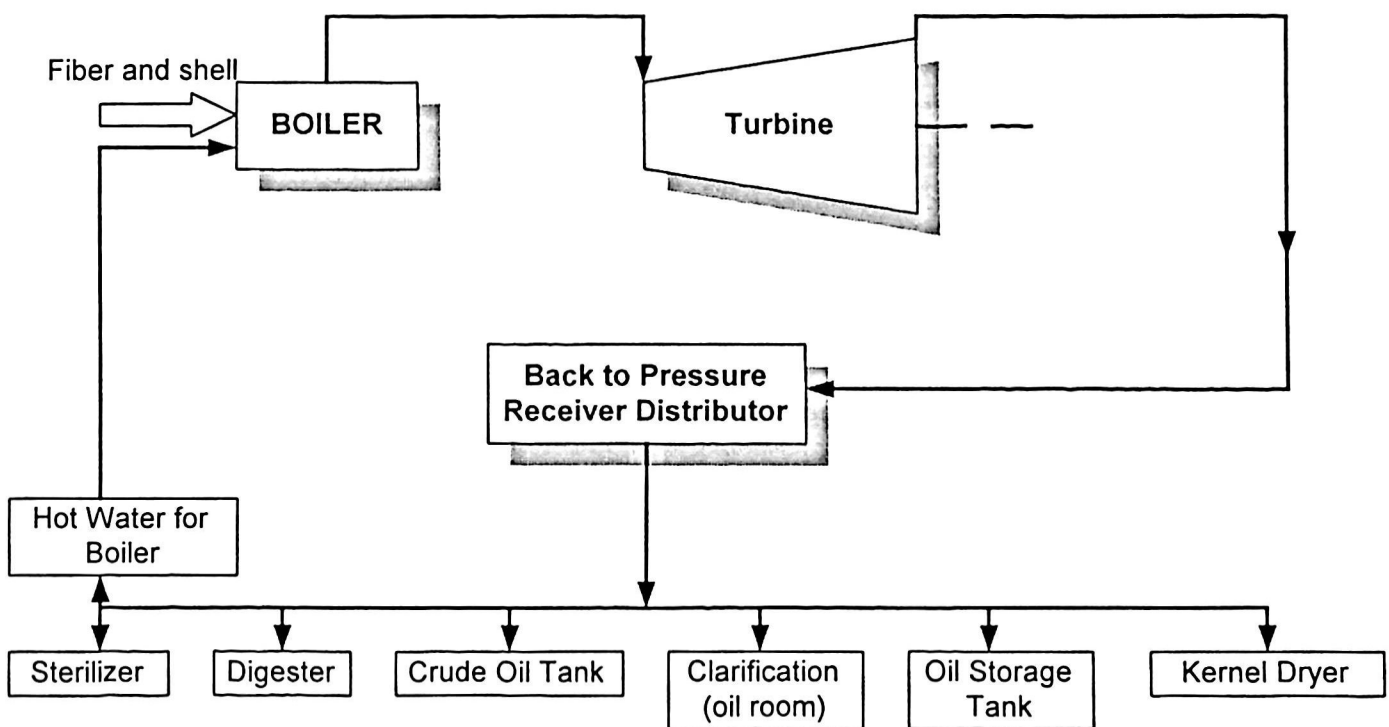

Figure 2.3 Steam distribution to the factory processes

2.1.2 Combustion Processes

Palm industry produces biomass waste materials such as fibre, shell and frond, bunch, palm oil effluent material (POEM) and tree bars. However only three of them (fibre, shell and bunch) are used as fertilizer and fuel for boiler and incinerator. Fibre and shell are used as fuel to generate electricity in steam power plant without wasting the money and material. According to An *et.al* (1993), 1 tonne of FFB produce 77 % of palm oil, 0.7 % of palm kernel, 14 to 15 % of fibre and 6 to 7 % of shell which generates 20 kW per hour electricity. A high combustion temperature generated from

waste combustion is influenced by the fuel profile like moisture content, foreign material and calorific value. Correspondingly, the quality of the fuel plays an important role in the combustion process (Li & Priddy, 1985).

The fuel from oil production process is transmitted to the furnace by using conveyer as mentioned in Section 2.1.1. The fuel inlet capacity depends on the load necessitated (Li & Priddy, 1985). The calorific value of palm oil is expressed in terms of Higher Heating Value (HHV) and Lower Heating Value (LHV). The difference is caused by the heat of evaporation of the water formed from the combustion of the hydrogen and the moisture in the material. The HHV can be obtained from bomb calorimeter experiment or by using Equation 2.1 (Keating, 1993) when the ultimate analysis of the fuel as listed in Table 2.1 is known.

$$HHV = 0.341C + 1.323H - 0.12O - 0.0153Ash + 0.0685 \quad \text{MJ/kg} \quad (2.1)$$

Table 2.1 Ultimate Analysis of the Selected Biomass (Hall & Overend, 1987)

Fuel	Element					
	C	H	O	N	S	Ash
Coconut shell & fibre	51.50	5.70	41.00	0.35	0.10	1.80
Sugar cane bagasse	46.95	6.10	42.65	0.30	0.10	3.90
Maize straw	47.09	5.54	39.79	0.81	0.12	5.77
Palm oil fibre	45.4	6.3	42.0	1.8	0	4.6
Palm oil shell	51.5	6.6	36.7	0.6	0	4.7
Wood	47.3	5.8	45.0	0.8	0	1.1

The HHV was determined experimentally using the bomb calorimeter according to the procedure given in Appendix A. The moisture content that lowers the combustion temperature of the fuel is assessed with moisture determination balance.

Table 2.2 describes the calorific value for fibre and shell as determined by using experimental results, Equation 2.1 and standard value provided by Palm Oil Research Industry Malaysia (PORIM). It shows the lower values for fibre but higher value for the

shell. It also shows the moisture content of the fuel which indicates fibre has higher moisture content than shell.

Table 2.2 Comparison of calorific value of palm waste material

Fuel (Palm waste)	Calorific value (MJ/kg)			Moisture content (%)
	Experiment	Equation	PORIM	Experiment
Fibre	16.6	18.8	18.4	24.7
Shell	24.8	21.9	20.7	18.4

Combustion takes place when rapid reaction between fuel and oxygen occurs. The combustion of fibre and shell is governed by the reaction of Equations 2.2 and 2.3 which are verified from ultimate analysis of carbon, oxygen, and hydrogen composition in Table 2.1 as demonstrated by Keating (1993).

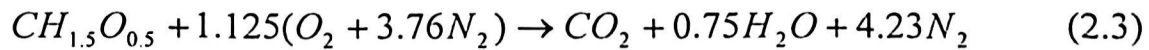

The combustion reaction depends on the air and fuel supply to the furnace. The air fuel ratio is an important parameter to be controlled. A complete reaction can be divided into partial equations, which can occur in any of the Equations 2.4, 2.5, 2.6 or 2.7 depending on the oxygen percentage in the air used for the fuel combustion.

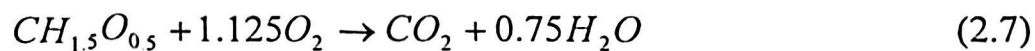
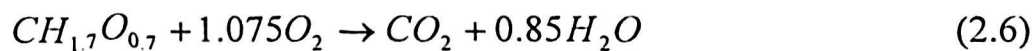
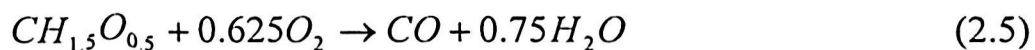
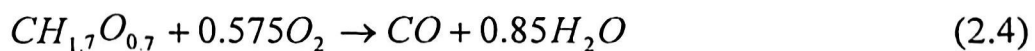

Incomplete reactions of Equations 2.4 and 2.5 happens when air quality in the furnace is low. Contrary to that, for Equations 2.6 and 2.7, a complete combustion is

achieved when adequate air is supplied to the combustion chamber. The air concentration that is supplied to the combustion chamber determines the dominant reaction.

Normally, nitrogen gas, N_2 takes part in the composition reaction because of its presence in air together with oxygen (as in Equations 2.2 and 2.3) to produce NO_x . However, N_2 is an inert gas and only provides NO_x at certain condition. NO_x is combination of NO_2 and NO , and it can be obtained in 3 types; thermal NO_x , forced NO_x and fuel NO_x (de Nevers, 1999; de blass, 1998). The thermal NO_x exists at combustion temperature above $1300^\circ C$, which source is from N_2 gas reaction. The forced NO_x is produced through the reaction between the nitrogen with activated carbon at low temperature. However, fuel NO_x occurs from the reaction between the nitrogen content in the fuel with oxygen. According to Karppenen (2000), biomass combustion in the furnace only produces fuel NO_x . The combustion of the fibre and shell that compose nitrogen will lead to fuel NO_x process (refer to Table 2.1). In addition, forced NO_x can form from incomplete combustion that produces activated carbon to react with nitrogen gas.

During combustion usually the fuel flow capacity is based on a ratio 70:30 for fibre and shell. More shell is used to flare the firing due to its high calorific value. However, this will result in increase of CO emission. CO which acts as a competitor for CO_2 is emitted when excess fuel resulting from incomplete combustion enters the furnace. At high temperature, CO_2 exists because of excess air supply (lean mixture). The lean mixture produces complete combustion and emits CO_2 (Lim, 2000), and rich mixture happens when excess fuel entering the oven lead to incomplete combustion. The production of CO has a heat of formation (9340 kJ) than CO_2 (34 019 kJ) in each kilogram of Carbon, thus resultancy in low thermal efficiency and higher emission. As

the amount of C in fibre is less than that in shell, fibre is commonly utilized as fuel during combustion compared to the shell. Normally there is no specific criteria for determining the amount of fuel required for the combustion to produce electricity. Instead, this relies on the workers' experience and the amount of waste material (fibre and shell) available from processed FFB.

Besides that, yield of unburnt material and oxide fuel are produced during incomplete combustion with low combustion temperature. These will form particulate matter (PM) that contains carbon. Hence, PM exists because of emitting unburn carbon and foreign material during incomplete combustion (Leong, 1986; de Blass, 1998; Androskoggin, 1998). As for SO₂, it only occurs in low concentration and can be neglected. It only exists in the smoke composition when there is corrosion problem in the stack gas. In the furnace and stack gas the release of SO₂ arises due to high smoke temperature (Li & Priddy, 1985). In addition, the combustion in the furnace may be started by adding diesel to the fuel to make it easy for ignition of the fibre and shell combustion. Thus, the sulphur contained in the diesel contributes to the release of very small amount of SO₂.

2.2 Smoke Emission from Boiler

A schematic diagram for typical processes in palm oil mill factory is shown in Figure 2.4. It shows all processes that have been discussed in Section 2.1. The critical processes that are most concerned in this thesis are marked with a dotted circle. It illustrates the process of burning fibre and shell as fuel for steam boiler power plant. As discussed in Part 2.1.3, from the combustion process, the pollutants released mainly consist of CO, NO_x, SO₂ and PM.

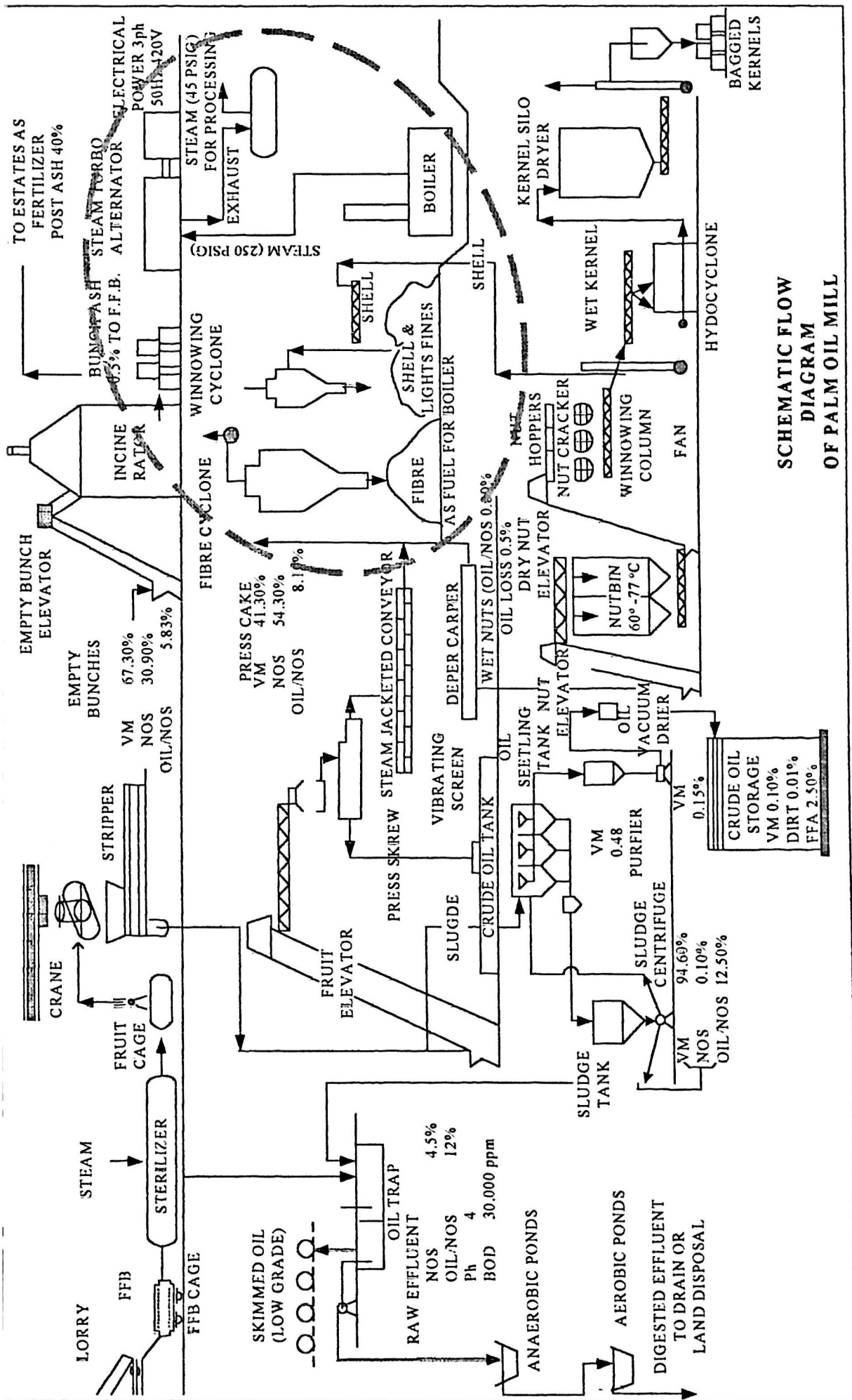

**SCHEMATIC FLOW
DIAGRAM
OF PALM OIL MILL**

Figure 2.4 Schematic diagram shows processes in palm oil mill (Palm Oil Factory Process Handbook, 1985)

2.2.1 Acts and Regulations

There are two main measurements in enforcing Malaysian Environmental Quality (Clean Air) Regulation 1978 section 51 which must be attained by each palm oil mill in Malaysia (Leong, 1986 and An *et.al*, 1993). There are:

- 1- Black smoke which must be less than chart No. 2 in Ringelmann chart as shown in Figure 2.5 for a period of 5 minutes aggregate per hour operation and 15 minutes for 24 hours operation.
- 2- Particle content at a rate less than 400 mg/Nm^3 , i.e. standard C before entering fresh air.

The first measurement is determined by monitoring the dark smoke observation at stack gas. The smoke opacity limit states that smoke emissions darker than Ringelmann chart No.2 (Figure 2.5) cannot exceed 5 minutes in an hour and 15 minutes a day. The second measurement is obtained by using the standard method to collect the dust that contains carbon particle, i.e. Method 5 isokinetic source sampling. The dust concentration limit is 400 mg/Nm^3 before discharging to the environment.

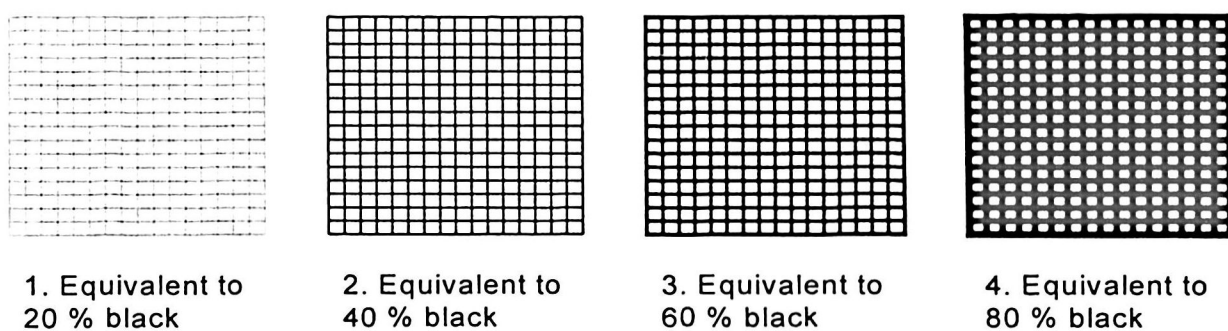

Figure 2.5 A sample of Ringelmann Smoke Chart (Lynn, 1976)

Malaysian regulation concentrates only on particulate content in smoke emission. The regulation focuses on high PM content in pollution that is visible through black smoke condition. The smoke emission from palm mill not only contains carbon

particles but also other pollutant gasses (NO_x, SO₂, CO) that threaten our health and safety. The regulations and limitation can be referred to Environmental Protective Agency of United States of America (EPAUSA) and other agencies in the world. Table 2.3 shows a list of typical pollutants emitted by chimney. In this research, the main consideration is on emissions of CO, NO_x, SO₂ and PM. Therefore, the Ministry of Industry standard as put in the last row of the Table 2.3 will be used as limitation of the boiler emission from palm oil mill in order to optimise operating condition which produces emission within the limit as will be discussed in Chapters 4 and 5.

Table 2.3 Standardization of exhaust/chimney separation (Ministry of Industry, USA, DOE, EPA-USA)

Rules	Pollutants			
	PM	NO _x	SO ₂	CO
DOE Malaysia, mg/Nm ³ (ppm)	400 (351)	350 (307)	1700 (1491)	
Tenaga Nasional Berhad (TNB) (mg/Nm ³)	40	980-1480	615-1640	
Typical North America (mg/Nm ³)	50	750	650	
World Bank (mg/Nm ³)	400	750	650	
Typical ASEAN (mg/Nm ³)	100	850-1700	940	
Typical Europe (mg/Nm ³)	100	1430	720	
Typical ASIA (mg/Nm ³)	100	1430	720	
Ministry of Industry USA, mg/Nm ³ (ppm)	400 (351)	470 (250)	1300 (500)	992 (870)

2.2.2 Smoke Emission Factors

The smoke emission factors are quite complex, and are influenced by many processes. There are no direct mathematical relationships available between the fuel combustions, boiler processes and power load produced by turbine. Even though

factors such as combustion, boiler process and mill process are related to each other in producing emission from steam power plant.

The combustion of fibre and shell is recognized as the main factor for boiler emission. The inconsistency in fuel flow affects combustion feature, steam generation, electric energy output and finally the emission (Weisman & Eckart, 1995). Despite the fuel transfer system being driven by a motor at constant speed to supply the fuel, problem exists as fibre and shell are not fed uniformly due to variation in the rate of loading to trolley. It will also cause fluctuating calorific value and moisture, or fuel quality, interrupting the combustion rate and temperature. Combustion furnace also needs to be cleaned from unburnt carbon that influences the combustion rate. Briefly, not only fuel capacity causes the emission, but also the fuel types and its quality play a role in the emission production and cannot be easily controlled.

Steam generation from palm waste material combustion depends on the power load required. Li & Priddy (1985) said the processes and power needed influence fuel inlet capacity, air and water. When power is unstable, it influences other factors to change their parameters automatically. High power electricity requires low pressure and high temperature steam (Weisman & Eckart, 1985). Therefore, the electric energy generated from turbine is proportional to the mill operation which involves many processes.

The air supply system is automatically controlled by the fuel inlet and inlet water capacity. The air supply will increase when excess of water in boiler drum and fuel flows in the oven. Although excess air supply is to achieve complete combustion, it also causes low combustion temperature and in return produces NO_x gas. However, less air supply causes CO emission water attendant less steam generation. It will decrease boiler efficiency, power generation and affect optimum heat transfer.

Hence, the air capacity, temperature and excess air are extremely complex to control and optimise in order to minimize smoke production. These processes are related to each other and are highly non-linear. They cannot be illustrated by direct equations to forecast the emission.

As discussed, the complex factors and contributors to many processes in the palm oil mill have no direct relationship in predicting the emission. The operations in the palm oil mill, the processes and operations involve the furnace, boiler and turbine which are closely related to each other. Figure 2.6 illustrates the complexity of factors which affect emission such as steam pressure (Sp), steam capacity (Sc), feed water (Fw), steam temperature (St), furnace combustion (Fc), boiler outlet (Bo), water level (Wl), ambient temperature (At), flue gas temperature (Ft), excess air (Ea), fibre flowrate (Ff), shell flowrate (Sf), power output (Po), oxygen (O₂) and carbon dioxide (CO₂). The output emissions include carbon monoxide (CO), nitrogen oxide (NO_x), sulphur dioxide (SO₂) and particulate matter (PM). These emissions are also related to each other as discussed in Section 2.1.2. Controlling emission quality can be done if the process of input factors can be controlled as the input indirectly is responsible the outputs or pollutants.

The discussion on the input and output variables with respect to the pollution is simplified by the illustration shown in Figure 2.6. Output parameters represent the pollutants as the effect from the boiler process while generating electricity. As these parameters are highly complex and non-linear and in various interaction between factors inside the process can be regarded as a black box. The main concern from this process is to monitor and subsequently control the release of emission. As the whole process involves the cause and effect or input and output, Artificial Neural Networks (ANN) is found to be a feasible method to model the boiler emission from palm oil mill.

ANN has the capability to model the combustion process consisting of input variables such as Sp, St, Fw, *etc.* as input factors and pollutants such as CO, NO_x, SO₂ and PM as output variables. ANN can also model the boiler, turbine and fuel combustion process in order to optimise and control the emission level released. The figure illustrates the suitability and possibilities of applying ANN in the current research, and ANN will be discussed in the following chapter.

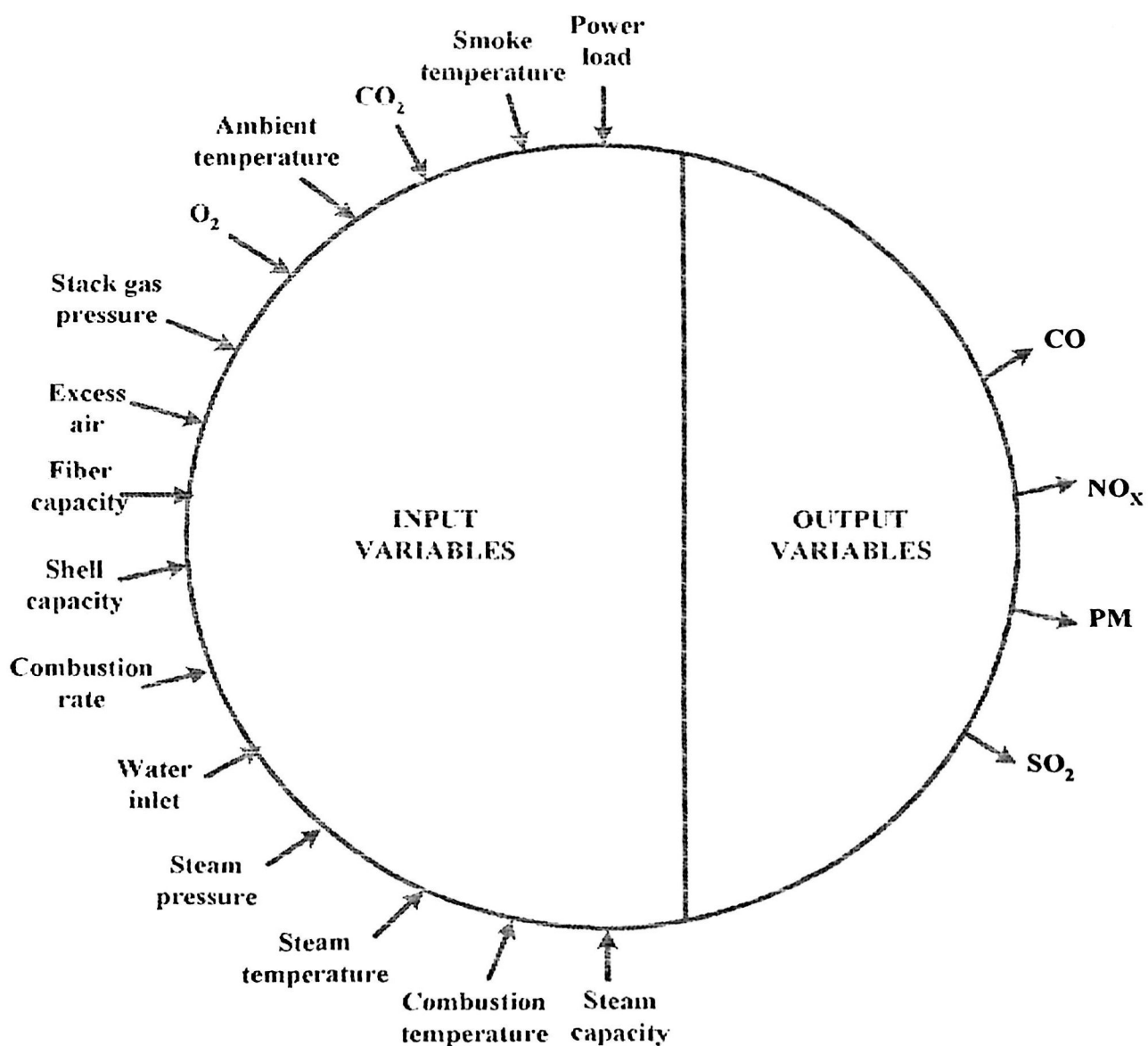

Figure 2.6 Input and output parameters for a typical boiler emission

Chapter 3

ARTIFICIAL NEURAL NETWORKS (ANN) IN PREDICTING BOILER EMISSION

In this chapter, fundamental, principle, structure and algorithm of Artificial Neural Networks (ANN) are introduced. An ANN is then developed by using Matlab, a highly efficient programming language which is now commonly used in engineering analysis. This chapter also discusses the previous work done by other researchers in the field of controlling emissions.

3.1 Fundamental of Artificial Neural Networks (ANN)

The concepts of Artificial Intelligent have given the possibility of realising machine learning based on human thinking method. According to Bartos (1997), Artificial Intelligent group comprises of ANN, expert system (ES), fuzzy logic (FL), Genetic Algorithms (GA) and other combination of AI like fuzzy neuro, neuro genetic and fuzzy genetic system. ANN is adapted from the human biological neuron that reacts to give an output result after receiving the information (Demuth & Beale, 1998). Actually, this ANN is based on signal processing using mathematical formulae that function as a human nerve. ANN must learn how to process input before they can be utilized in an application. The process of training an ANN involves adjusting the input weights on each neuron such that the output of the network is consistent with the desired output. This involves the development of a training file, which consists of data for each input node and the correct or desired response for each of the network's output

nodes. Once the network is trained, only the input data are provided to the network, which then recalls the response of the network learned during training.

A biological neuron as shown in Figure 3.1 has a roughly spherical cell body called soma. The signals generated in soma are transmitted to other neurons through an extension on the cell body called axon or nerve fibres. Another kind of extensions around the cell body like bushy tree called the dendrites, which are responsible for receiving the incoming signals generated by other neurons. In the brain, there is liquid flow that contains code information that uses electrochemical media, the so-called neurotransmitters from the synapses toward the axon. The axon of each neuron transmits the information to other neurons. The neuron receives information at the synapses from a large number of other neurons. It is estimated that each neuron may receive stimuli from as many as 10 000 other neurons.

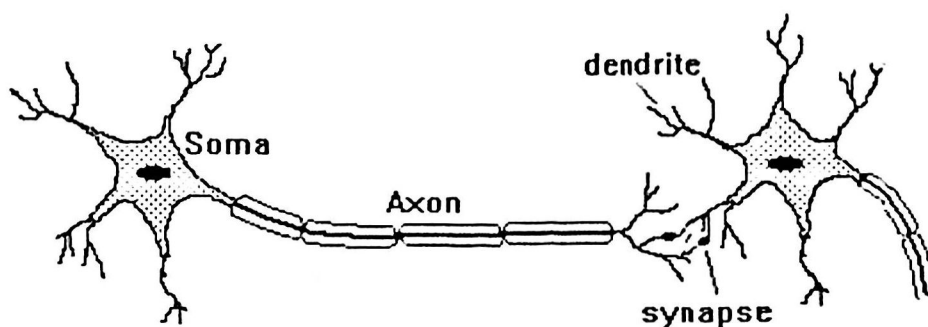

Figure 3.1 A simplified model of a biological neuron (Freeman & Skapura, 1991)

Figure 3.2 shows a highly simplified model of an artificial neuron, which may be used to simulate some important aspects of the real biological neuron. A basic model consists of one set of inputs, adding block and activation function. It also shows that one set of input is introduced to input neuron represented by I_1, I_2, I_3 vector which is equivalent to the synapse in biological neuron. Each signal multiplied with weights $w_1, w_2, and w_3$ equals to the strength of synapse link in biological neuron. The node

functions as body cell that will sum all weighted inputs in algebra and will produce one unit of O_j . The vector can be illustrated in mathematical model as follows:

$$O_j = \sum_{i=1}^n I_i w_i \quad (3.1)$$

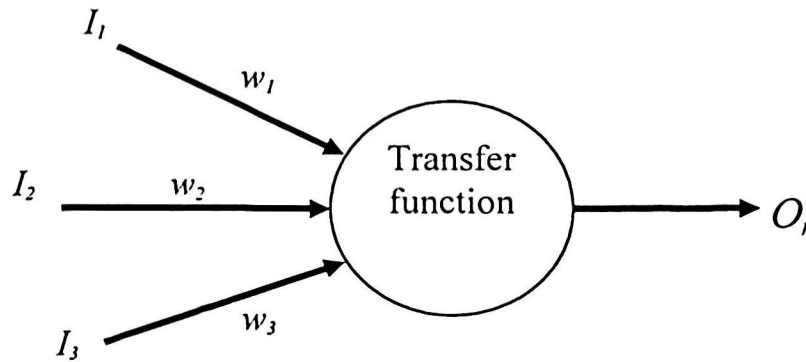

Figure 3.2 A simplified model of an artificial neuron

The strength of ANN depends directly on the weight numbers increase when the nodes increase. If an active unit is more than limit value, the unit will produce output value that contain in Threshold Logic Unit (TLU) which was introduced by McCulloch and Pitts in the year 1943 (Freeman & Skapura, 1991). This function labelled as b shown in Equation 3.2 will increase the total value $I_i w_i$. A large b value reacts as a weak action compared to negative or small value which reacts as the strong action according to the strength of neurons, as shown in Equation 3.2 as:

$$O_j = \sum_{i=1}^n I_i w_i + b_i \quad (3.2)$$

3.2 Structure of Artificial Neural Networks (ANN)

Neural computing is an alternative to programmed computing which is a mathematical model inspired by biological models. This computing system is made up of a number of artificial neurons and a huge number of interconnections between them.