

**DEVELOPMENT OF LINKAGE MECHANISM
FOR IN-PIPE ROBOT**

NIK MUHAMMAD ASHRAF BIN CHE MEGAT

UNIVERSITI SAINS MALAYSIA

2019

**DEVELOPMENT OF LINKAGE MECHANISM
FOR IN-PIPE ROBOT**

by

NIK MUHAMMAD ASHRAF BIN CHE MEGAT

**Thesis submitted in fulfilment of the requirements
for the degree of
Bachelor of Engineering (Manufacturing Engineering with Management)**

May 2019

ACKNOWLEDGEMENT

In the very beginning, I would like to give my deepest gratitude towards Universiti Sains Malaysia (USM) for giving an opportunity for me to pursue my degree in Manufacturing Engineering with Management course and people that give morale support throughout my one to make Final Year Project success.

First of all, I would like to thank Dr. Norzalilah Mohamad Nor for supervise and give guidance on how to doing final year research and her advice for me to overcome all the challenges during my research project period. I learnt many things under her supervision and be able to complete my project within time given.

Next, I would like to give my deepest gratitude to the assistant engineers in School of Mechanical Engineering especially Mr. Halim and Mr. Hashim for assisting me and give advice on how to do fabrication process and electrical works in laboratory.

Last but not least, a very much thanks to Madam Jamilah Hassan Basri in USM Engineering Library to assist me on how to do thesis and other documentation works. I would like to thank to my family and friends for encouragement and support during my final year project from start until the end.

TABLE OF CONTENTS

ACKNOWLEDGEMENT	ii
TABLE OF CONTENTS	iii
LIST OF TABLES	vi
LIST OF FIGURES	vii
LIST OF SYMBOLS	ix
LIST OF ABBREVIATIONS	x
ABSTRAK	xi
ABSTRACT	xii
CHAPTER 1 INTRODUCTION	1
1.1 Overview	1
1.2 Project Background	3
1.3 Problem Statement	4
1.4 Objective	4
1.5 Project scope	5
CHAPTER 2 LITERATURE REVIEW	7
2.1 Overview	7
2.2 Types of In-pipe Robot	7
2.2.1 Pipe Inspection Gauge (PIG)	8
2.2.2 Wheeled Type In-Pipe Robot.....	9
2.2.3 Caterpillar Type In-Pipe Robot.....	9
2.2.4 Wall Pressing Type In-Pipe Robot.....	10
2.2.5 Walking Type In-Pipe Robot	11
2.2.6 Worm Type In-Pipe Robot.....	11
2.2.7 Plastic Elastic Joint Pipeline Inspection Robot.....	12
2.2.8 Propeller Type In-Pipe Robot	13

2.2.9	One-Inch Pipe Inspection Robot	13
2.2.10	In-Pipe Robot with Underactuated Twisting Joint.....	14
2.3	Existing Attach Mechanism of In-Pipe Robot	15
2.3.1	Triangular Structured Driving Mechanism	15
2.3.2	Flexible Wheel Mechanism Drive In-Pipe Robot.....	17
2.3.3	Magnetic Locomotion In-Pipe Robot	19
2.4	Existing Cornering Mechanism of In-Pipe Robot.....	21
2.4.1	Caterpillar Track Wheel-Based Robot.....	21
2.4.2	Crawling-Based In-Pipe Robot	24
2.4.3	Articulated In-Pipe Robot	26
CHAPTER 3 METHODOLOGY.....		28
3.1	Case Study on Existing Robot.....	28
3.2	Project Methodology Flow	29
3.3	Proposed Solutions	30
3.4	SolidWorks Modelling	31
3.4.1	Free Ball Joint Mechanism of In-Pipe Robot.....	32
3.4.2	Spring Mechanism of In-Pipe Robot	32
3.5	Robot Body Calculation	33
3.6	Spring Stiffness for Suspension	35
3.7	Motor Installation	36
3.8	Material Selection for The Drive Wheels	37
3.9	Control System for In-Pipe Robot.....	41
3.10	Cost Estimation for The Prototype.....	43
3.10.1	Cost for Removal Parts	44
3.11	Experiment and Testing	45
CHAPTER 4 RESULTS AND DISCUSSION		47
4.1	Capability of The In-Pipe Robot Prototype.....	47

4.2	Experimental Results.....	47
4.3	Power Consumption of DC Motor	51
4.4	Advantages of In-Pipe Robot Compared with Existing Robot	52
CHAPTER 5 CONCLUSION.....		53
5.1	Overview	53
5.2	Limitation	53
5.3	Future Work	54
REFERENCES.....		55
APPENDIX		

LIST OF TABLES

	Page
Table 1.1 Project scope and description.....	5
Table 3.1 The Part Model and Details	37
Table 3.2 Cost Estimation for the Prototype	43
Table 3.3 Cost for Removal Parts	44
Table 4.1 In-pipe robot prototype turn in left	48
Table 4.2 In-pipe robot prototype turn in right	49
Table 4.3 In-pipe robot prototype move in straight pipe	50

LIST OF FIGURES

	Page
Figure 2.1 Pipe Inspection Gauge (PIG)	8
Figure 2.2 Wheeled Type In-Pipe Robot	9
Figure 2.3 Caterpillar Type In-Pipe Robot	9
Figure 2.4 Wall Pressing Type In-Pipe Robot	10
Figure 2.5 Walking Type In-Pipe Robot.....	11
Figure 2.6 Worm Type In-Pipe Robot	11
Figure 2.7 Plastic Elastic Joint Pipeline Inspection Robot	12
Figure 2.8 Propeller Type In-Pipe Robot.....	13
Figure 2.9 One-Inch Pipe Inspection Robot.....	13
Figure 2.10 In-Pipe Robot with Underactuated Twisting Joint	14
Figure 2.11 DeWaLoP Maintenance Unit System.....	16
Figure 2.12 Isometric view and front view of DeWaLoP in expansion mode.....	17
Figure 2.13 The mechanism structure of the robot	18
Figure 2.14 The horizontal mechanism of the robot's driving mechanism	18
Figure 2.15 The top view of flexible wheel mechanism robot	19
Figure 2.16 Geometry of magnetic robot.....	20
Figure 2.17 Transmission system & Motor layout, with part No. 1: Motor, 9: Gear, 10: Driving Shaft, 11: Wheel Gear, 14: Magnetic Wheels.	20
Figure 2.18 Magnetic robot cross-section diagram.....	21
Figure 2.19 Front view of caterpillar track wheel-based robot.....	22
Figure 2.20 Isometric view of robot.....	22
Figure 2.21 different view of flexible link.....	23
Figure 2.22 Adjustable dimension of flexible link.....	23

Figure 2.23 Graphical simulation of robot when takes cornering.....	24
Figure 2.24 The in-pipe robot overall structure	25
Figure 2.25 Coupling methods of back supporting and telescopic mechanism.....	25
Figure 2.26 In-pipe robot turning test in the pipe elbow.....	26
Figure 2.27 The overall view of articulated in-pipe robot	27
Figure 2.28 Articulation, universal joint and stiffening spring installed in the robot joint.....	27
Figure 3.1 Project Flow Chart.....	29
Figure 3.2 Free ball joint on the connector	30
Figure 3.3 Overview of In-Pipe Robot Model	31
Figure 3.4 Free ball joint mechanism of in-pipe robot prototype	32
Figure 3.5 Free body diagram of the in-pipe robot	33
Figure 3.6 Total weight of the in-pipe robot	34
Figure 3.7 Compression test for the in-pipe robot's leg suspension spring.....	35
Figure 3.8 Force/distance graph for in-pipe robot suspension spring.....	36
Figure 3.9 DC 6V mini geared motor	36
Figure 3.10 Schematic diagram for L298D motor control shield wiring. Black: negative terminal, Red: positive terminal, Green: ground	42
Figure 3.11 Schematic diagram for Arduino UNO and Bluetooth module wiring....	43
Figure 3.12 T-branch pipe.....	46
Figure 3.13 In-pipe robot body	46
Figure 5.1 Suggested ball wheel on the stator body of in-pipe robot	54

LIST OF SYMBOLS

F_s	Friction force	N
F	Normal force	N
W_b	Robot's body weight	Kg
P	Power	Watt
V	Voltage	V
I	Current	A

LIST OF ABBREVIATIONS

PIG	Pipe Inspection Gauge
CAD	Computer Aided Design
IDE	Integrated Development Environment
3D	Three Dimension
IC	Integrated Circuit
PWM	Pulse Width Modulation
PVC	Polyvinyl Chloride

DEVELOPMENT OF LINKAGE MECHANISM FOR IN-PIPE ROBOT

ABSTRAK

Kerja pemeriksaan di dalam saluran paip telah dilakukan oleh manusia untuk memerhati dan menetusahkan mana-mana kebocoran terutamanya di dalam industri loji, bahan kimia, gas semula jadi dan pelantar minyak. Persekitaran kerja ini adalah sangat berbahaya dan berkemungkinan besar memberi bahaya kepada pekerja sama ada kesan jangka masa pendek atau panjang. Untuk menyelesaikan masalah ini, robot pemeriksa dalam paip telah diperkenalkan bagi menggantikan kerja ini dan berevolusi untuk menawarkan prestasi yang lebih baik berbanding dengan kerja pemeriksaan secara manual. Tujuan projek ini adalah untuk merekabentuk robot pemeriksa dalam paip yang berkebolehan untuk bergerak dalam paip and membelok dalam keadaan stabil di penjuru paip yang mempunyai pelbagai diameter di pasaran dan juga industri. Rekabentuk robot termasuk bagaimana untuk membelok di sudut paip dan luas permukaan yang bersentuhan bagi robot untuk memastikan robot sentiasa stabil apabila bergerak menyelusuri saluran paip. Untuk memastikan mobiliti robot di dalam saluran paip, sistem kawalan telah digunakan pada badan robot untuk memusingkan tayar menggunakan Arduino UNO sebagai “minda” yang menyalurkan elektrik kepada sistem lokomotif robot. Selepas melakukan uji kaji, didapati robot dapat melakukan pusingan di selekoh paip dan bergerak dengan baik di saluran paip lurus. Walaubagaimanapun, pemilihan bahan yang bersesuaian pada bebola tayar akan memberi kesan yang berbeza terhadap cengkaman pada dinding paip. Justeru, bahan yang bersesuaian adalah getah yang disalut dengan bebola bagi memastikan cengkaman pada dinding paip. Projek ini sedikit sebanyak dapat menyumbang kepada mekanisma robot untuk melalui selekoh paip.

DEVELOPMENT OF LINKAGE MECHANISM FOR IN-PIPE ROBOT

ABSTRACT

Pipeline inspection works has been done by human to observe and identify any leakage especially in industrial plant, chemical, natural gas and oil rig. This job environment is the most dangerous and high possibility to give hazard for workers in short or long term effect. To encounter this problem, in-pipe inspection robot has been introduced to replace the job and evolved to offer better performance compared with manual inspection. The purpose of this project is to design a in-pipe robot which is capable to move in the pipe and turning in stable condition in the pipe junction with various diameter in the market and industry. The design of robot including the mechanism on how to turn in the corner of the pipe and the area of contact for the robot to keep stable while moving through the pipeline. To make the robot mobile in the pipeline, control system is implemented in the robot's body to rotate the wheels by using Arduino UNO as a "brain" that transmit electrical supply to locomotion of the robot. After conducting experiment, robot is observed can make turn in the pipe junction and make good mobility in straight pipe. However, suitable material selection at the ball wheels will give different effect towards grip performance on pipe wall. Thus, the suitable material is coating the rubber on ball wheels to ensure better gripping performance. This project can give contribution on the robot's mechanism to passing through the junction of pipe.

CHAPTER 1

INTRODUCTION

1.1 Overview

Pipeline infrastructures are very important to the environment and society. The purpose of doing pipeline is to transport the water, natural gas, chemicals and oil, but the most significant disadvantage is leakage of the pipeline. Thus, to avoid the leakage in the pipeline, the in-pipe robot is the best solution as an alternative for human to inspect the condition in the pipe. Leakage of the pipeline problem is not involving economics issue only, but also the human safety, environment, sustainability and health issue [1].

Nowadays, there are various type and size of piping, pipeline may on the vertical and horizontal position and the connection also vary such as T-shape, L-shape, curved radius pipe and S-shape pipe. The researches have challenges to design the in-pipe robot which can move in the stated pipeline connection

The robot can be classified into two types of locomotion which is the active locomotion and passive locomotion. Active locomotion means the robot can move in the pipeline actively and accurately control the speed as well as the direction by carrying drive source. While the passive wheels means the robot is having difficulties to control their speed and area because disability in controlled movement. In-pipe robot with passive locomotion moving due to the flow of the liquid inside the pipe [2].

There are many in-pipe robots that are designed and marketed nowadays which is the Pipe Inspection Gauge (PIG), wheeled type robot, caterpillar type robot, wall-pressed type robot, walking type robot and screw type robot. Each of the robots got their advantages and disadvantages. For example, the PIG type robot is not equipped

with any motor and it just using the flow in the pipe. The disadvantage of the caterpillar type robot is does not had ability to climb up the vertical pipeline [2], yet the drive mechanism of the in-pipe robot still needs to be studied which the speed of the motor either its can be implemented in all type of robot.

1.2 Project Background

In-pipe robot is designed to move in the pipeline and doing inspection work. This method is easier for human to find out which area in the pipeline that has leakage and prevent any environment issues by fixing it immediately. For example, any leakage in chemical substances or oil will affect the environment especially water which is the essential source for human being [2].

Besides, if the damage in the pipelines are not fixed immediately it will be more difficult if any natural disaster happens due to difficulties to find out the origin location of defect. By putting the sensor along the pipelines are too much costing to implementing, so the in-pipe robot is the most reasonable way to do any inspection work inside the pipeline. The advantage of robot is it can work through diameter sizes of pipe ranging from 184.34mm until 224.06mm and doing hazardous things besides the labor cost can be reduced. The study of mechanism of robot is necessary by knowing the best way for the robot to moving and adapt with various size of pipeline.

Next, in-pipe robot will be an alternative for human to do work that can affect their health and safety inside the pipeline. Working in dangerous workplace such as chemical pipeline has higher possibility for worker in danger because just a small spark can ignite a tremendous flame in the chemical substances plant. Therefore, the control interface design and drive mechanism of the in-pipe robot need to be study, the design of the in-pipe robot involves the mechanism of robot movement (Locomotion), electrical (wiring), shape/weight distribution of the robot and programming. Each of the aspect of the design will affect the performance and reliability of the robot.

In the previous project, the robot is designed based on triangle shape with wheel on each of the edges of the robot as drive mechanism to move [19]. The limitation that can be seen in previous project are the robot cannot turn in T-junction, unable to working well in pipe that have fluid due to the electronic component and the robot is too heavy to work through vertical pipe wall.

1.3 Problem Statement

From the previous research in term of in-pipe robot, there are several problems that need to be solved [19]. The weight of the robot from the previous project is too heavy, the objective to reduce the weight is to make the robot able to climb up the vertical pipeline and against the gravity force towards it. Then, the electrical components are not well isolated due to its purpose to work under the wet condition in the pipeline. In the other hand, the front ball wheels are not in contact with the pipe wall and it will increase friction force towards the wheel and difficult for the robot to moves properly.

1.4 Objective

This project carried out with objective:

To improve the robot's stability when turning into the pipeline T-junction by replace free joint ball in the center of the body connector.

1.5 Project scope

The project scope will be shown in the Table 1.1:

Table 1.1 Project scope and description

Scope	Description
Identify the problem	<ul style="list-style-type: none">• Understanding the general situation in real life• Read the literature review related to the project• Find the importance of the in-pipe robot uses
Doing analysis on the existing in-pipe robot design	<ul style="list-style-type: none">• Study the type of existing in-pipe robots.• Find out the limitation of the existing robot• Study the mechanism of the robot
Design the in-pipe robot	<ul style="list-style-type: none">• Sketch and build a 3-D model robot• Design the free-moving locomotive robot• Do calculation for the related force needed
Prototype fabrication and cost estimation	<ul style="list-style-type: none">• Build a prototype• Cost calculation for the fabrication of prototype

Experiment and testing	<ul style="list-style-type: none">• Testing the prototype and analyze the function
Result analysis	<ul style="list-style-type: none">• Make analysis and identify the future work

CHAPTER 2 LITERATURE REVIEW

2.1 Overview

This literature review discusses about the existing in-pipe robots that had been researched and developed besides the type of in-pipe robot, the existing moving mechanism and the mechanism that attach to the wall are discussed.

2.2 Types of In-pipe Robot

The variation of in-pipe robot today was developed to carry out the tasks that is dangerous to be handle by human. In many years, researchers were trying to develop the mechanism for the robot to do inspection work by imitating the animal locomotion initially, later the evolution of locomotion had evolved to rotation and wheeled inspection robot [7].

2.2.1 Pipe Inspection Gauge (PIG)

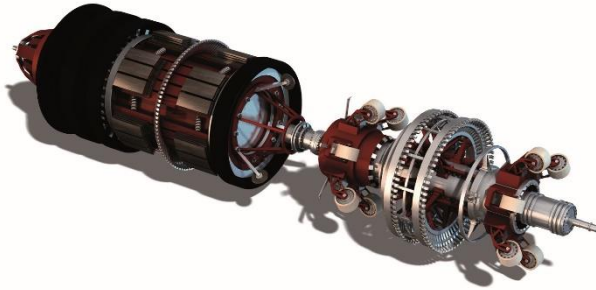

Figure 2.1 Pipe Inspection Gauge (PIG)

This Pipe Inspection Gauge in-pipe robot in Figure 2.1 has advantage of moving without actuator. It drives with the help of force from the fluid or gas pressure to make it move. The disadvantage of this robot is difficult to control the speed because it depends on the speed of fluid and gas through the pipeline and when in junction. [3][4][5][6]

2.2.2 Wheeled Type In-Pipe Robot

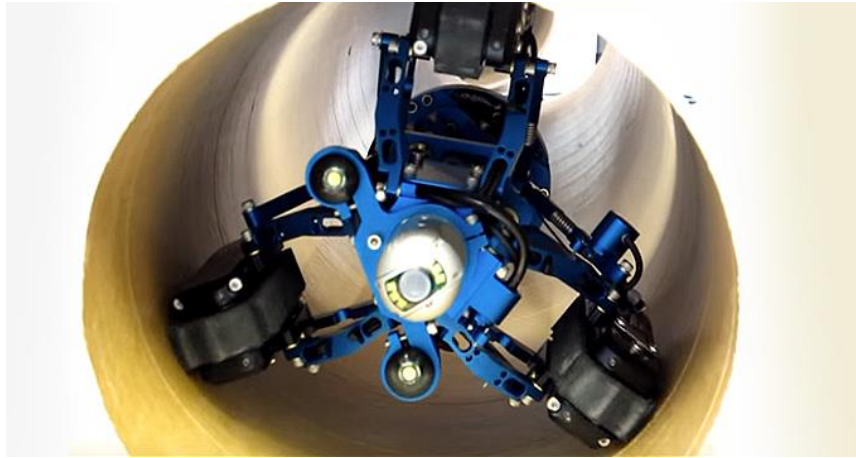

Figure 2.2 Wheeled Type In-Pipe Robot

In Figure 2.2, this Wheeled Type In-Pipe Robot is built with the simple design and able to steer but this type of robot only used for horizontally pipelines. The disadvantage of this robot is the possibility to slipping when climb up to the steeper or vertical pipeline. [3][4][5][6]

2.2.3 Caterpillar Type In-Pipe Robot

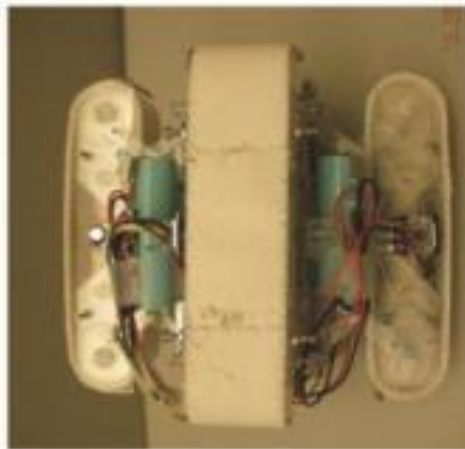

Figure 2.3 Caterpillar Type In-Pipe Robot

The mechanism of Caterpillar Type In-Pipe Robot is almost similar with the wheeled type in-pipe robot, this type of robot can work in horizontal pipe. The wall-pressed system allows the robot to adapt with complex pipe condition. Caterpillar wheel as caterpillar system to provide good traction force to move forward and backward.

2.2.4 Wall Pressing Type In-Pipe Robot



Figure 2.4 Wall Pressing Type In-Pipe Robot

This Wall Pressing Type In-Pipe Robot in Figure 2.4 is useful both horizontal and vertical pipeline. The robot contains flexible links that can attach with the pipe wall and avoid the robot slip in vertical pipe. [3][4][5][6]

2.2.5 Walking Type In-Pipe Robot



Figure 2.5 Walking Type In-Pipe Robot

Walking Type In-Pipe Robot are less competency in the industry. This is because the mechanism of the robot is difficult to control due to many actuators mounted on the robot. The design of the robot is complex and need detailed work and experience to develop and control the robot. [3][4][5][6]

2.2.6 Worm Type In-Pipe Robot

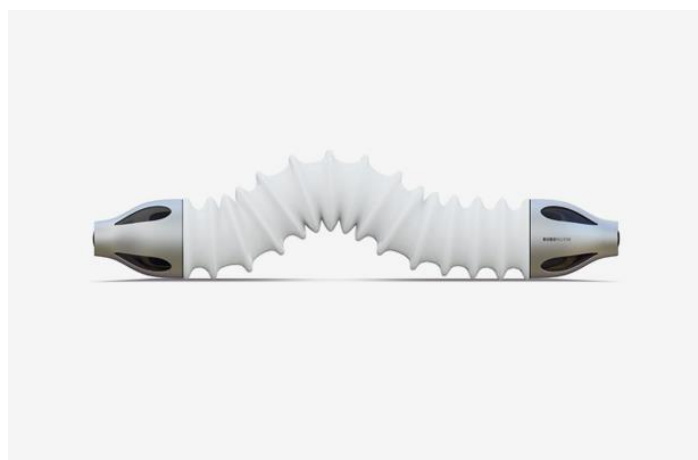

Figure 2.6 Worm Type In-Pipe Robot

Worm Type In-Pipe Robot will move like inchworm through the pipeline which is the front part will move first followed by the back part. The mechanism is like transverse wave, the body of the robot will expand and contract in order of sequence to move forward and backward. This robot is preferred for the small diameter of pipe but commonly this robot is slower in mobility. [3][4][5][6]

2.2.7 Plastic Elastic Joint Pipeline Inspection Robot



Figure 2.7 Plastic Elastic Joint Pipeline Inspection Robot

Plastic Elastic Joint Pipeline Inspection Robot consists of four links and they are connected by three spring joints. The front rolling and driving units are symmetric with the rear rolling and driving units, respectively. The hemispherical wheels do not rotate around the roll-axis by reaction force when moving along the pipe axis. It can drive along the vertical pipe due the angle of rolling motor may be adjusted by an absolute encoder attached to the rear of the motor [7].

2.2.8 Propeller Type In-Pipe Robot

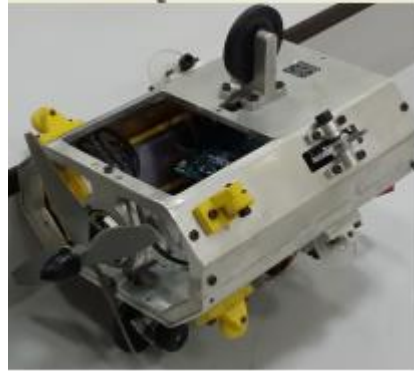

Figure 2.8 Propeller Type In-Pipe Robot

The mechanical design of this Propeller Type In-Pipe Robot fulfilled key requirements which is always able to travel in a pipeline with elbows and maintain sufficient contact with the inner surface of the pipe besides durable and light weight construction. The chassis of this robot is using aluminum which is formed using two sheets for ease of disassembly during the testing stages and fastened together using screw. Six wheels are touching the inner surface of the pipe to ensure the robot maintains smooth contact with the inner surface of the pipe, this helps maintain smooth robot motion and prevents any edges of the robot from hitting the pipeline [8].

2.2.9 One-Inch Pipe Inspection Robot

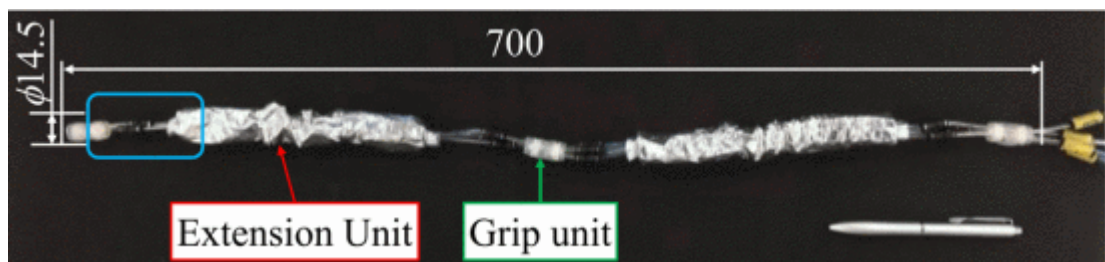

Figure 2.9 One-Inch Pipe Inspection Robot

One-Inch Pipe Inspection Robot is proposed to have active traction type flexible inchworm robot (PI-RO I). The robot that have mechanism that outputs the propulsive force and the traction force actively as a method to make the both force high. To achieve this mechanism, the grip unit for holding the robot inside the pipe and an extension unit for propulsion and traction need to be developed. This robot is developed to inspect the buried pipe supplying gas and water to homes. The motion pattern of this robot is by grip unit in front of the axial extension actuator holds the pipe and the robot moves forward by repeating these motions. Furthermore, when the front extension unit extends, for the structure grip unit, when the pressure is applied to this unit, the rubber tube expands and holds the robot inside the pipe [9].

2.2.10 In-Pipe Robot with Underactuated Twisting Joint

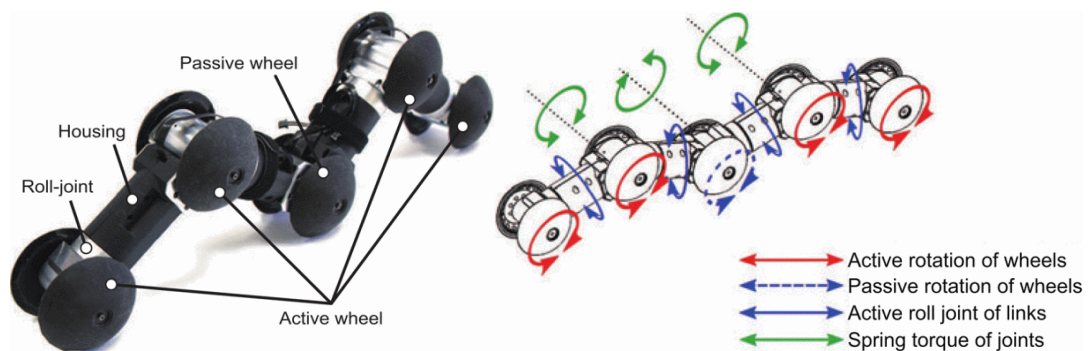

Figure 2.10 In-Pipe Robot with Underactuated Twisting Joint

In-Pipe Robot with Underactuated Twisting Joint is developed by both active and passive rotational degree of freedom, respectively. The robot is invented of three

elastic joints that are passively bent by torsional springs. The springs press all wheels against the inner surface of the pipe to make sure the robot does not fall down in a vertical pipe. The new mechanism can twist its body like a helix to change the orientation around the pipe axis compared to the previous developed robot [10] [11]. A DC geared motor is installed in each link (housing). Each link is divided into two parts that can rotate relative to each other and are supported by bearings. [12]

2.3 Existing Attach Mechanism of In-Pipe Robot

To make the variation of robot that can be fit in any condition on pipeline, the moving mechanism is necessary to be developed. There are several development of robot's moving mechanisms that can be referred and study for future progress in the project.

2.3.1 Triangular Structured Driving Mechanism In-Pipe Robot

This inspection robot called DeWaLoP (Developing Water Loss Prevention) system includes the conventional inspection of the pipe system, which carried out using a cable-tethered robot with an onboard video system.

Luis A. Mateos, Kai Zhou and Markus Vincze had made this mobile robot uses a differential wheel drive, which makes the robot able to promptly adjust its position to remain in the middle of the pipe while moving. Next, the maintenance unit of the structure is able to expand to expand or compress with a Dynamical Independent Suspension System (DISS) [13].



Figure 2.11 Triangular Structured Driving Mechanism In-Pipe Robot

The Triangular Structured Driving Mechanism In-Pipe Robot structure, by expanding its wheels can create a stiff structure inside the pipe, hence the robot system can work without any vibration or involuntary movement from the inertia and accurately hold the pipe joint: by compressing its wheeled legs. The structure consists of six wheels paired with legs that separated by 120 degree of angle between each other. The legs are functioned as the support system along the center of the pipe.

The concept of this robot is mimicking a cylindrical robot that able to cover the 3D in-pipe space but modifies the standard cylindrical robot into double cylindrical arm, where both arms are connected to the central axis of the maintenance unit and located 180 degree each other.

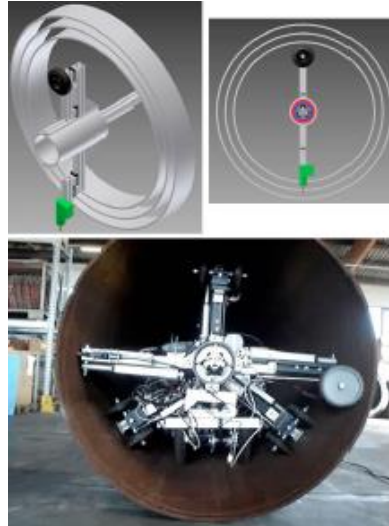

Figure 2.12 Isometric view and front view of Triangular Structured Driving Mechanism In-Pipe Robot

2.3.2 Flexible Wheel Mechanism Drive In-Pipe Robot

This Flexible Wheel Mechanism Drive In-Pipe Robot is autonomous self-driven inline inspection robot was developed by et al. [14]. The flexible mechanism structure is imitating on how spider movement can adapt the irregular surface by its flexibility to pass through the obstacle area or maneuver at a corner or junction.

The main mechanism structure composed of two parts: the body tube and the three flexible clutch mechanisms. The exterior parts of the robot consist of three sets of flexible clutch mechanisms that are positioned with 120 degrees of angle interval, which can make the body suit well in the pipeline with round cross section.

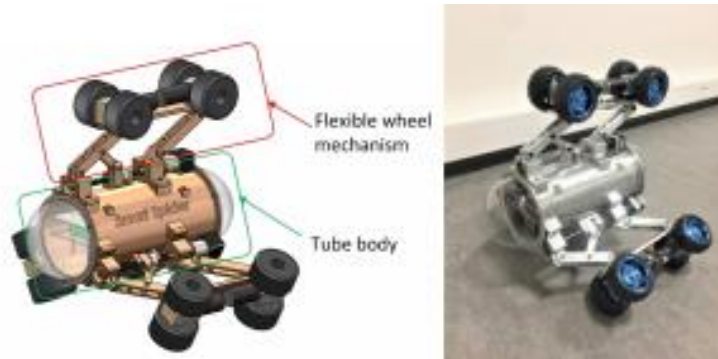

Figure 2.13 The mechanism structure of the Flexible Wheel Mechanism Drive In-Pipe Robot

The driving mechanism is responsible to actuate the 4-bar linkage clutch by extending and contracting, followed to the wheels unit to fit in to different size of pipeline. The screw rod will revolve clockwise or anticlockwise and will be driven by stepper motor. Therefore, the U-shape slider and the connector slider crossing on the screw rod can move forward and backward respectively. Then, the angle of 4-bar linkage will move according to the position of the slider.

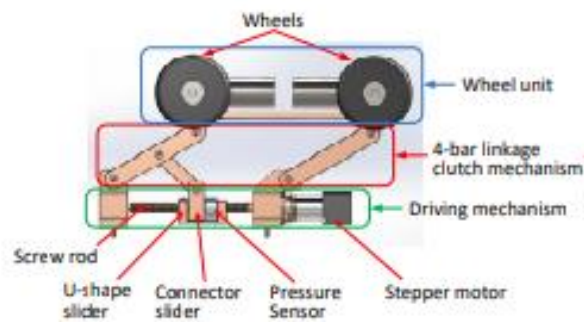

Figure 2.14 The horizontal mechanism of the Flexible Wheel Mechanism Drive In-Pipe Robot

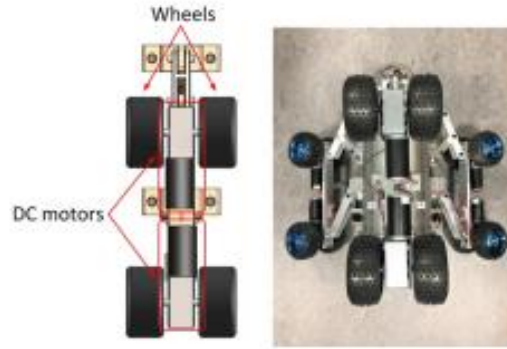

Figure 2.15 The top view of flexible wheel mechanism of Flexible Wheel Mechanism Drive In-Pipe Robot

2.3.3 Magnetic Locomotion In-Pipe Robot

The Magnetic Locomotion In-Pipe Robot mechanism is introduced et al. [15] for in-pipe robot that intended to travel from small diameter pipelines to larger bores. The target is the ferrous pipeline which have diameter range of 50mm – 1250mm. Magnetic adhesion is performing adhesion without need for wall-pressing system at the larger diameter of pipeline. It can be seen that the wall pressing robot severely limits the range of the pipelines that can be inspected by a single robot.

The magnetic pipe robot was designed to enter 50mm internal diameter ferrous pipelines. The robot is equipped with magnetic wheels, including soft rubber wheels printed using soft-printed material. The main body of the robot is considered as two separated halves and screwed together after the implementation of motors, electronics and battery. The wireless Bluetooth radio transceiver is mounted on top of the chassis directly with the Arduino FTDI.

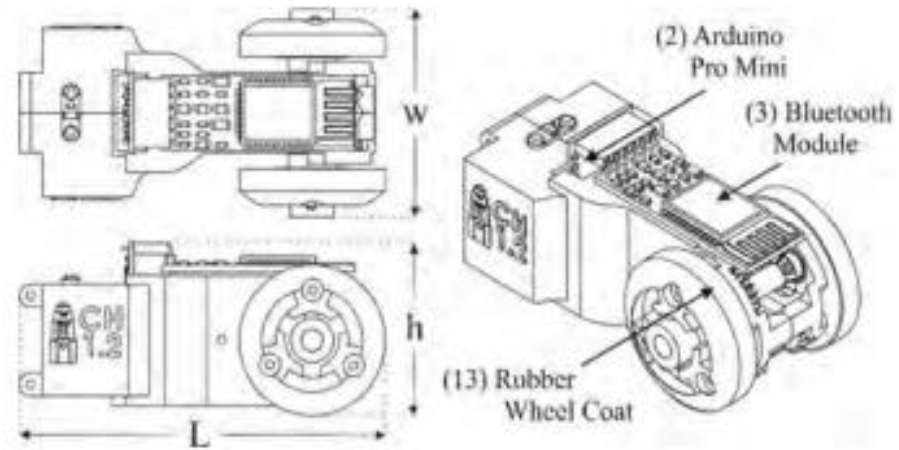

Figure 2.16 Geometry of Magnetic Locomotion In-Pipe Robot

The constraint of this design is to fit the robot in 50mm pipeline. Due to that limitation, the motors are mounted perpendicular to the driveshaft and the wheels. The motor sits parallel on top of the other. Each drive one gear train with transmission through a bevel gear.

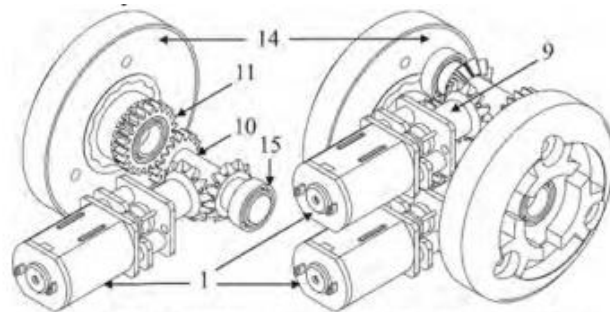

Figure 2.17 Transmission system & Motor layout of Magnetic Locomotion In-Pipe Robot, with part No. 1: Motor, 9: Gear, 10: Driving Shaft, 11: Wheel Gear, 14: Magnetic Wheels.

Instead of having magnet directly in contact with the inner surface of the pipe, they are housed between two steel plate. It can have two benefits, redirection of the magnetic flux into the steel plates and protection of the neodymium magnets. Corrosion and shock impact can cause degradation and fracturing of the magnets, by encapsulating them is significantly safer.

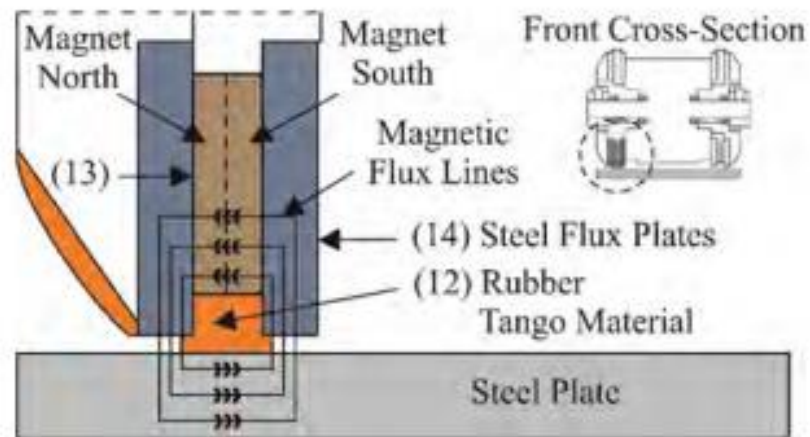

Figure 2.18 Magnetic Locomotion In-Pipe Robot cross-section diagram

2.4 Existing Cornering Mechanism of In-Pipe Robot

The cornering mechanism is the essentials for in-pipe robot to turning in the junction of the pipe. The turning radius and angle plays important role on the stability of the robot before and after passing through the junction.

2.4.1 Caterpillar Track Wheel-Based Robot

The conceptual design of this Caterpillar Track Wheel-Based Robot consists of main body, three foldable links and three caterpillar wheels tracks [16]. The wheel tracks developed as wall-pressed to increase gripping force that enable it to tackle wall without any slipping. In addition, the robot applying tri-axial differential mechanism as the caterpillar tracks are arranged at an angle of 120 degrees with respect to one another.



Figure 2.19 Front view of Caterpillar Track Wheel-Based Robot



Figure 2.20 Isometric view of Caterpillar Track Wheel-Based Robot

To take cornering in the elbow of the pipeline, the radius of curvature needs to be considered. Therefore, it is important to determine the correct size of the robot. The flexible link plays important role in employing wall-pressed mechanism to provide additional gripping force to wheels and to connect the main body frame and tracks as well. The flexible links are made from U shape aluminum bar and 3mm acrylic sheet (Perspex). U shaped aluminum used as platform and Perspex forming a cross “X” pattern.

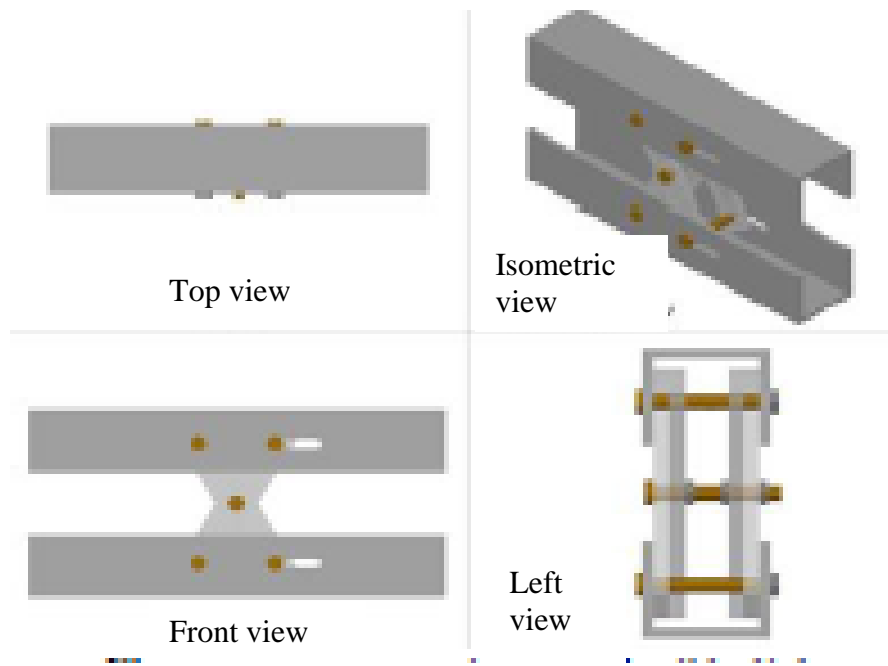

Figure 2.21 different view of flexible link of Caterpillar Track Wheel-Based Robot

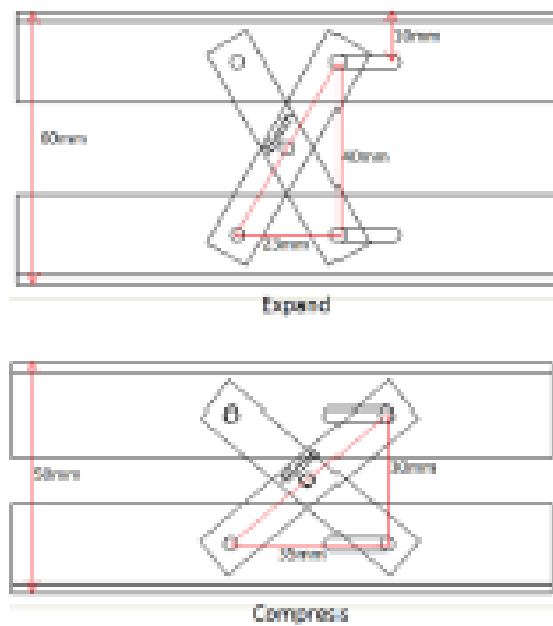

Figure 2.22 Adjustable dimension of flexible link of Caterpillar Track Wheel-Based Robot

Figure 2.23 shows the graphical simulation of the robot during cornering in the 90 degrees elbow. The figures are arranged in sequence to get a clear perspective on how the robot pass through the elbow of pipe.

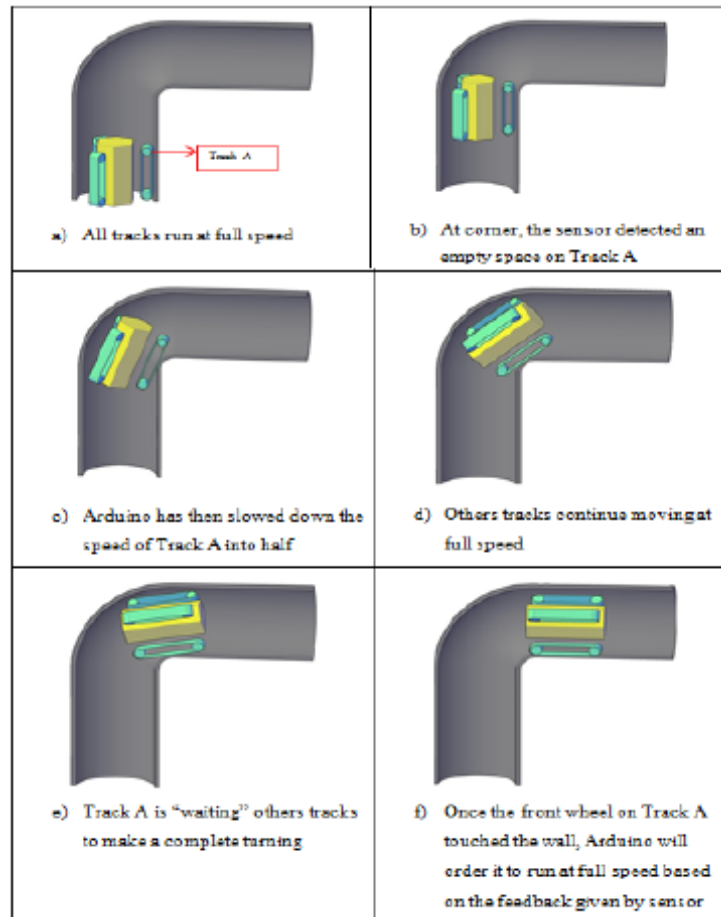

Figure 2.23 Graphical simulation of Caterpillar Track Wheel-Based Robot when takes cornering

2.4.2 Crawling-Based In-Pipe Robot

The Crawling-Based In-Pipe Robot can be seen composed with three parts: front, back supporting structure and central telescopic structure [17]. The front and supporting back structure are umbrella-based shape stand to support pipe shell and movement for robot. Central telescopic structure adopts parallelogram structure to stretch out and draw back driven by motor and screw rod to move ahead. The soft