

Neural Cognition Processing of Working Memory in Traumatic Brain  
Injury (TBI) patients – An ERP and A Beamforming Analysis of EEG  
and MEG Data

By

AISHAH SAKINAH BINTI ZAHID

Thesis submitted in partial fulfilment of the requirements for the  
degree of Master in Integrated Neuroscience

July 2019

## ACKNOWLEDGEMENT

My utmost gratitude to the Almighty Allah, for granting me a good health, strength and determination to complete this thesis. A heartfelt gratitude to my beloved parents and family members who are always supporting me physically and mentally. A very special gratitude to my supervisor Dr. Mohammed Faruque Reza for all the guidance throughout the completion this thesis. My highest appreciation and respect for his willingness to share his knowledge and expertise and being very committed to help me in completing my thesis. I would like to thank my co-supervisors too, Dr. Nor Azila Noh from Faculty of Medicine, USIM and Dr. Hamwira Yaacob from Department of Computer Science, IIUM. Sincere appreciation to Mr. Hazim Omar and Mrs. Alwani Liyana Ahmad for helping me to execute the EEG and MEG session and to Dr. Nadia for recruiting the patients for my study. I also would like to extend my gratitude to my friends for being my ultimate mental support. My acknowledgement also goes to all the lectures, staff and science officers of Neuroscience Department. A special acknowledgement to Prof Dato' Jafri Malin Abdullah, Director, Centre for Neuroscience Services and Research (P3Neuro), Health Campus, Universiti Sains Malaysia, 16150 Kubang Kerian, Kelantan to include my study in the TRGS grant.

## TABLE OF CONTENTS

|  |       |
|--|-------|
| Acknowledgement                            | II    |
| Table of Contents                          | III   |
| List of Tables                             | X     |
| List of Figures                            | XII   |
| List of Abbreviations                      | XVI   |
| List of Symbols                            | XVIII |
| Abstrak                                    | XIX   |
| Abstract                                   | XXI   |
|  |       |
| CHAPTER 1 - INTRODUCTION                   |       |
| 1.1 Background of Study                    | 1     |
| 1.1.1 Definition of TBI                    | 1     |
| 1.1.2 Epidemiology of TBI                  | 2     |
| 1.1.3 Classification of TBI                | 4     |
| 1.1.4 Severity measurement of TBI          | 5     |
| 1.1.5 Symptoms and effects of TBI          | 6     |
| 1.2 Neural oscillation/Brain oscillation   | 7     |
| 1.2.1 Definition of Neural Oscillation     | 7     |
| 1.2.2 Classification of Neural Oscillation | 8     |
| 1.3 Working memory and N-back task         | 9     |
| 1.3.1 Working Memory                       | 9     |
| 1.3.2 N-back                               | 10    |
| 1.4 EEG/MEG/ERP                            | 12    |
| 1.4.1 EEG                                  | 12    |
| 1.4.2 MEG                                  | 13    |

|  |    |
|--|----|
| 1.4.3 ERP  | 15 |
| 1.4.3.1 P300   | 16 |
| 1.4.3.2 N170   | 17 |
| 1.5 Beamforming Analysis   | 18 |
| 1.6 Objective(s)   | 19 |
| 1.6.1 General Objective  | 19 |
| 1.6.2 Specific Objectives  | 19 |
| 1.7 Hypothesis   | 20 |
| 1.7.1 Null Hypothesis  | 20 |
| 1.7.2 Research Hypothesis  | 20 |
| 1.8 Rationale of Study   | 20 |
| <br>   |    |
| CHAPTER 2 – LITERATURE REVIEW  |    |
| 2.1 Neural Oscillations during working memory                              | 21 |
| 2.2 N170 component in response to single letter perception as the stimulus | 22 |
| 2.3 P300 as an electrophysiology cognitive index in TBI patients           | 24 |
| 2.4 Beamforming analysis on MEG and EEG data                               | 25 |
| <br>   |    |
| CHAPTER 3 – METHODOLOGY  |    |
| 3.1 Ethics   | 27 |
| 3.2 Consent form   | 27 |
| 3.3 Sampling method  | 27 |
| 3.3.1 Convenience method   | 27 |
| 3.3.2 Purposive method   | 28 |
| 3.4 Research Participants  | 28 |
| 3.5 Study design   | 28 |
| 3.5.1 Experimental study   | 28 |

|                               |    |
|-------------------------------|----|
| 3.5.2 Case-control study      | 29 |
| 3.6 Sample size calculation   | 29 |
| 3.7 Inclusion                 | 31 |
| 3.7.1 Healthy participants    | 31 |
| 3.7.2 TBI participants        | 31 |
| 3.8 Exclusion                 | 31 |
| 3.8.1 Healthy participants    | 31 |
| 3.8.2 TBI participants        | 32 |
| 3.9 Procedure                 | 32 |
| 3.9.1 Consent form briefing   | 32 |
| 3.9.2 Preparation of EEG/MEG  | 32 |
| I) EEG                        | 32 |
| II) MEG                       | 34 |
| A) Head Positioning procedure | 34 |
| 3.9.3 EEG/MEG Recording       | 36 |
| I) N-back task                | 36 |
| A) 0-back                     | 36 |
| B) 1-back                     | 37 |
| C) 2-back                     | 37 |
| D) 3-back                     | 38 |
| 3.9.4 ERP waveform analysis   | 39 |
| 3.9.4.1 Neural Oscillation    | 39 |
| 3.9.4.2 EEG and MEG           | 39 |
| 3.9.5 Statistical analysis    | 41 |
| 3.9.5.1 Neural Oscillation    | 41 |
| 3.9.5.2 ERP components        | 42 |
| 3.9.6 Beamforming Analysis    | 42 |

|   |    |
|---|----|
| 3.9.7 Study flow chart  | 44 |
| CHAPTER 4 – RESULTS   |    |
| 4.1 Participants  | 47 |
| 4.2 Neural Oscillation  | 49 |
| 4.2.1 Fast Fourier Transformation (FFT) spectral analysis                         | 49 |
| A) EEG  | 49 |
| B) MEG  | 49 |
| 4.2.2 Statistical Analysis  | 50 |
| 4.2.2.1 EEG   | 50 |
| 1) Power in Delta Frequency band during Target condition and Non-Target condition | 50 |
| 2) Power in Theta Frequency band during Target condition and Non-Target condition | 51 |
| 3) Power in Alpha Frequency band during Target condition and Non-Target condition | 52 |
| 4) Power in Beta Frequency band during Target condition and Non-Target condition  | 54 |
| Conclusion for Neural oscillation differences of EEG/ERP data                     | 55 |
| 4.2.2.2 MEG   | 56 |
| 1) Power in Delta Frequency band during Target condition and Non-Target condition | 56 |
| 2) Power in Theta Frequency band during Target condition and Non-Target condition | 57 |
| 3) Power in Alpha Frequency band during Target condition and Non-Target condition | 58 |
| 4) Power in Beta Frequency band during Target condition and Non-Target condition  | 60 |
| Conclusion for Neural oscillation differences of MEG/ERP data                     | 61 |
| 4.3 ERP components  | 61 |
| 4.3.1 Statistical Analysis  | 64 |

|   |     |
|---|-----|
| 4.3.1.1 EEG   | 64  |
| I) P300 Amplitude                                       | 64  |
| II) P300 Latency  | 67  |
| III) N170 Amplitude                                     | 69  |
| IV) N170 Latency  | 72  |
| 4.3.1.2 MEG   | 75  |
| I) P300 Amplitude                                       | 75  |
| II) P300 Latency  | 78  |
| III) N170 Amplitude                                     | 82  |
| IV) N170 Latency  | 84  |
| 4.4 Beamforming analysis                                | 88  |
| 4.4.1 EEG   | 93  |
| I) P300 during Target condition                         | 93  |
| II) P300 during Non-Target condition                    | 94  |
| III) N170 during Target condition                       | 95  |
| IV) N170 during Non-Target condition                    | 96  |
| 4.4.2 MEG   | 97  |
| I) P300 during Target condition                         | 97  |
| II) P300 during Non-Target condition                    | 98  |
| III) N170 during Target condition                       | 99  |
| IV) N170 during Non-Target condition                    | 100 |
| CHAPTER 5 - DISCUSSION                                  |     |
| 5.1 Introduction  | 101 |
| 5.2 Neural Oscillation                                  | 101 |
| 5.3 ERP components                                      | 103 |
| 5.3.1 P300 Amplitude ( $\mu\text{V}$ ) and latency (ms) | 103 |
| 5.3.1.1 During Target condition                         | 103 |

|   |     |
|---|-----|
| 5.3.1.2 During Non-Target condition                     | 105 |
| 5.3.2 N170 Amplitude ( $\mu\text{V}$ ) and latency (ms) | 106 |
| 5.3.2.1 During Target condition                         | 106 |
| 5.3.2.2 During Non-Target condition                     | 106 |
| 5.4 Beamforming Analysis                                | 107 |
| 5.4.1 EEG   | 108 |
| 5.4.1.1 P300 component during target condition          | 108 |
| 5.4.1.2 N170 component during target condition          | 109 |
| 5.4.1.3 P300 component during non-target condition      | 109 |
| 5.4.1.4 N170 component during non-target condition      | 110 |
| 5.4.2 MEG   | 110 |
| 5.4.2.1 P300 component during target condition          | 110 |
| 5.4.2.2 N170 component during target condition          | 111 |
| 5.4.2.3 P300 component during non-target condition      | 111 |
| 5.4.2.4 N170 component during non-target condition      | 112 |
| <br>CHAPTER 6 - CONCLUSION                              |     |
| 6.1 Summary of results                                  | 113 |
| 6.2 Limitations   | 114 |
| 6.3 Recommendation and future studies                   | 114 |
| <br>REFERENCES  | 115 |
| <br>APPENDICES  |     |
| APPENDIX 1 : TRGS ETHICAL APPROVAL                      | 125 |
| APPENDIX 2 : CONSENT FORMS (ENGLISH VERSION)            | 127 |
| APPENDIX 3 : CONSENT FORM (MALAY VERSION)               | 142 |



|   |     |
|---|-----|
| APPENDIX 4 : EEG AND MEG EQUIPMENT        | 158 |
| APPENDIX 5 : BEAMFORMING ANALYSIS RESULTS | 160 |

## LIST OF TABLES

|            |   |    |
|------------|---|----|
| Table 1.1  | Data tabulation of Major Trauma cases by Gender   | 3  |
| Table 1.2  | Data tabulation of Major Trauma Cases by Age Group  | 3  |
| Table 1.3  | Data tabulation of Major Trauma Cases by Race   | 3  |
| Table 1.4  | Major Trauma Cases by Cause of Injury   | 3  |
| Table 1.5  | Major Trauma Cases by Glasgow Coma Scale (GCS)  | 4  |
| Table 3.1  | Sample size calculation by Power and Sample Size (PS) software.   | 30 |
| Table 3.2  | Tabulated information of the test involved, variables and objective of the test conducted.  | 45 |
| Table 3.3  | Tabulated information of the test involved, variables and objective of the test conducted.  | 46 |
| Table 4.1  | Information about the injury region and the duration of the post-injury of TBI patients   | 48 |
| Table 4.18 | EEG P300 Amplitude (Mean $\pm$ SD) of Healthy and TBI participants during Target Condition and Non-Target condition                                     | 64 |
| Table 4.19 | EEG P300 Latency (Mean $\pm$ SD) of Healthy and TBI participants during Target condition and Non-Target condition.                                      | 67 |
| Table 4.20 | EEG N170 Amplitude (Mean $\pm$ SD) of Healthy and TBI participants during Target condition and Non-Target condition.                                    | 70 |
| Table 4.21 | EEG N170 Latency (Mean $\pm$ SD) of Healthy and TBI participants during Target Condition and Non-Target condition                                       | 73 |
| Table 4.22 | MEG P300 Amplitude (Mean $\pm$ SD) of Healthy and TBI participants during <i>N</i> -back Target and Non-Target condition from a set of 15 brain regions | 76 |
| Table 4.23 | MEG P300 latency (Mean $\pm$ SD) of Healthy and TBI participants during <i>N</i> -back Target and Non-Target condition from a set of 15 brain regions   | 79 |
| Table 4.24 | MEG N170 Amplitude (Mean $\pm$ SD) of Healthy and TBI participants during <i>N</i> -back Target and Non-Target condition from a set of 15 brain regions | 82 |

|            |   |    |
|------------|---|----|
| Table 4.25 | MEG N170 latency (Mean $\pm$ SD) of Healthy and TBI participants during <i>N</i> -back Target and Non-target condition from a set of 15 brain regions | 85 |
| Table 4.26 | Summary of the beamforming analysis for P300 and N170 during target condition of EEG data   | 89 |
| Table 4.27 | Summary of the beamforming analysis for P300 and N170 during non-target condition of EEG data   | 90 |
| Table 4.28 | Summary of the beamforming analysis for P300 and N170 during target condition of MEG data   | 91 |
| Table 4.29 | Summary of the beamforming analysis for P300 and N170 during non-target condition of MEG data   | 92 |

## LIST OF FIGURES

|             |   |    |
|-------------|---|----|
| Figure 1.1  | A representation of jolt or blow to the head  | 1  |
| Figure 1.2  | Graphic representation of brain damage that may occur inside of TBI patient.                                | 5  |
| Figure 1.3  | The effects of TBI on the brain's lobe  | 7  |
| Figure 1.4  | Brainwaves and its ranges   | 9  |
| Figure 1.5  | Working memory model by Allen Baddeley  | 10 |
| Figure 1.6  | Example of graphical representation of 1, 2 and 3 n conditions in n-back paradigm with letter as a stimulus | 11 |
| Figure 1.7  | Illustration on how the electrodes and the EEG output will be conveyed during EEG session                   | 13 |
| Figure 1.8  | Example of MEG recording  | 14 |
| Figure 1.9  | Example of the averaging process of EEG segments to produced ERP  | 16 |
| Figure 1.10 | Example of P300 wave  | 17 |
| Figure 1.11 | The N170 fluctuated downwards with a greater amplitude when the stimuli are a face                          | 18 |
| Figure 1.12 | Illustration on the idea of beamforming approach  | 18 |
| Figure 3.1  | Illustration on position of participants, The PC monitor and the cap during EEG session.                    | 33 |
| Figure 3.2  | important parts of the head for HP procedure  | 35 |
| Figure 3.3  | MEG machine inside the Magnetic-shielded room (MSR)   | 41 |
| Figure 4.1  | Demographic information of Healthy participants by Age  | 47 |
| Figure 4.2  | Demographic information of TBI participants by Age  | 48 |
| Figure 4.3  | EEG Frequency result in power spectrum by using FFT analyzer of Healthy 1 participant                       | 49 |
| Figure 4.4  | MEG Frequency result in power spectrum by using FFT analyzer of Healthy 1 participant                       | 49 |
| Figure 4.5  | Power in Delta frequency band (Mean $\pm$ SD) during Target condition                                       | 50 |
| Figure 4.6  | Power in Delta frequency band (Mean $\pm$ SD) during Non-Target condition                                   | 51 |

|             |   |    |
|-------------|---|----|
| Figure 4.7  | Power in Theta frequency band (Mean $\pm$ SD) during Target condition   | 52 |
| Figure 4.8  | Power in Theta frequency band (Mean $\pm$ SD) during Non-Target condition   | 52 |
| Figure 4.9  | Power in Alpha frequency band (Mean $\pm$ SD) during Target condition   | 53 |
| Figure 4.10 | Power in Alpha frequency band (Mean $\pm$ SD) during Non-Target condition   | 54 |
| Figure 4.11 | Power in Beta frequency band (Mean $\pm$ SD) during Target condition  | 55 |
| Figure 4.12 | Power in Beta frequency band (Mean $\pm$ SD) during Non-Target condition  | 55 |
| Figure 4.13 | Power in Delta frequency band (Mean $\pm$ SD) during Target condition   | 56 |
| Figure 4.14 | Power in Delta frequency band (Mean $\pm$ SD) during Non-Target condition   | 57 |
| Figure 4.15 | Power in Theta frequency band (Mean $\pm$ SD) during Target condition   | 58 |
| Figure 4.16 | Power in Theta frequency band (Mean $\pm$ SD) during Non-Target condition   | 58 |
| Figure 4.17 | Power in Alpha frequency band (Mean $\pm$ SD) during Target condition   | 59 |
| Figure 4.18 | Power in Alpha frequency band (Mean $\pm$ SD) during Non-Target condition   | 59 |
| Figure 4.19 | Power in Beta frequency band (Mean $\pm$ SD) during Target condition  | 60 |
| Figure 4.20 | Power in Beta frequency band (Mean $\pm$ SD) during Non-Target condition  | 61 |
| Figure 4.21 | EEG/ERP waveforms of a healthy 1 (Top) and TBI 1 (Bottom) participant during target (Green) and non-target condition (Pink) | 62 |
| Figure 4.22 | MEG/ERP waveforms of a healthy 1 (Top) and TBI 1 (Bottom) participant during target (Green) and non-target condition (Pink) | 63 |
| Figure 4.23 | Graph of P300 amplitude ( $\mu$ V) of healthy and TBI participants during target condition                                  | 66 |
| Figure 4.24 | Graph of P300 amplitude ( $\mu$ V) of healthy and TBI participants during Non-target condition                              | 66 |
| Figure 4.25 | Graph of P300 Latency (ms) of healthy and TBI participants during target condition  | 69 |
| Figure 4.26 | Graph of P300 Latency (ms) of healthy and TBI participants during Non-target condition                                      | 69 |
| Figure 4.27 | Graph of N170 amplitude ( $\mu$ V) of healthy and TBI participants during target condition                                  | 72 |
| Figure 4.28 | Graph of N170 amplitude ( $\mu$ V) of healthy and TBI participants during Non- target condition                             | 72 |
| Figure 4.29 | Graph of N170 Latency (ms) of healthy and TBI participants during target condition  | 74 |

|             |  |    |
|-------------|--|----|
| Figure 4.30 | Graph of N170 Latency of healthy and TBI participants during Non-target condition  | 75 |
| Figure 4.31 | Bar Graphs of MEG P300 Amplitude ( $\mu\text{V}$ ) of Healthy and TBI participants during N-back Target condition from a set of 15 brain regions     | 78 |
| Figure 4.32 | Bar Graphs of MEG P300 Amplitude ( $\mu\text{V}$ ) of Healthy and TBI participants during N-back Non-Target condition from a set of 15 brain regions | 78 |
| Figure 4.33 | Bar Graphs of MEG P300 Latency (ms) of Healthy and TBI participants during N-back Target condition from a set of 15 brain regions                    | 81 |
| Figure 4.34 | Bar Graphs of MEG P300 Latency (ms) of Healthy and TBI participants during N-back Non-Target condition from a set of 15 brain regions                | 81 |
| Figure 4.35 | Bar Graphs of MEG N170 Amplitude ( $\mu\text{V}$ ) of Healthy and TBI participants during N-back Target condition from a set of 15 brain regions     | 84 |
| Figure 4.36 | Bar Graphs of MEG N170 Amplitude ( $\mu\text{V}$ ) of Healthy and TBI participants during N-back Non-Target condition from a set of 15 brain regions | 84 |
| Figure 4.37 | Bar Graphs of MEG N170 Latency (ms) of Healthy and TBI participants during N-back Target condition from a set of 15 brain regions                    | 87 |
| Figure 4.38 | Bar Graphs of MEG N170 Latency (ms) of Healthy and TBI participants during N-back Non-Target condition from a set of 15 brain regions                | 87 |
| Figure 4.39 | P300 localization in the brain of Healthy 1 participant during target condition  | 93 |
| Figure 4.40 | P300 localization in the brain of TBI 1 participant during target condition  | 93 |
| Figure 4.41 | P300 localization in the brain of Healthy 6 participant during non-target condition  | 94 |
| Figure 4.42 | P300 localization in the brain of TBI 5 participant during non-target condition  | 94 |
| Figure 4.43 | N170 localization in the brain of Healthy 1 participant during target condition  | 95 |
| Figure 4.44 | N170 localization in the brain of TBI 1 participant during target condition  | 95 |
| Figure 4.45 | N170 localization in the brain of Healthy 6 participant during non-target condition  | 96 |

|             |   |     |
|-------------|---|-----|
| Figure 4.46 | N170 localization in the brain of TBI 5 participant during non-target condition     | 96  |
| Figure 4.47 | P300 localization in the brain of Healthy 7 participant during target condition     | 97  |
| Figure 4.48 | P300 localization in the brain of TBI 3 participant during target condition         | 97  |
| Figure 4.49 | P300 localization in the brain of Healthy 7 participant during non-target condition | 98  |
| Figure 4.50 | P300 localization in the brain of TBI 6 participant during non-target condition     | 98  |
| Figure 4.51 | N170 localization in the brain of Healthy 7 participant during target condition     | 99  |
| Figure 4.52 | N170 localization in the brain of TBI 3 participant during target condition         | 99  |
| Figure 4.53 | N170 localization in the brain of Healthy 7 participant during non-target condition | 100 |
| Figure 4.54 | N170 localization in the brain of TBI 6 participant during non-target condition     | 100 |

## LIST OF ABBREVIATIONS

|       |  |
|-------|--|
| TBI   | Traumatic Brain Injury                         |
| NTrD  | National Trauma Database                       |
| MOH   | Ministry of Health                             |
| ETD   | Emergency and Trauma Department                |
| GCS   | Glasgow Coma Scale                             |
| DAI   | Diffuse axonal injury                          |
| Hz    | Hertz  |
| ERO   | Event-Related-Oscillation                      |
| ERP   | Event-Related-Potential                        |
| WM    | Working Memory                                 |
| EEG   | Electroencephalogram                           |
| MEG   | Magnetoencephalography                         |
| MRI   | Magnetic Resonance Imaging                     |
| fMRI  | Functional Magnetic Resonance Imaging          |
| MSI   | Magnetic Source Imaging                        |
| MSR   | Magnetic-Shielded Room                         |
| ms    | milisecond                                     |
| P3    | P300 Wave                                      |
| Fm/fm | Frontal Midline                                |
| HUSM  | Hospital Universiti Sains Malaysia             |
| CIRT  | Center for Innovation in Research and Teaching |
| PS    | Power and Sample Size                          |
| HPI   | Head Position Indicator                        |
| ISI   | Interstimulus Interval                         |
| ICA   | Independent Component Analysis                 |



|     |                             |
|-----|-----------------------------|
| TSE | Temporal Spectral Evolution |
| SDH | Subdural Hematoma           |
| SAH | Subarachnoid Hemorrhage     |
| EDH | Extradural Hemorrhage       |
| FFT | Fast Fourier Transformation |
| BAs | Brodmann Areas              |

## LIST OF SYMBOLS

|           |           |
|-----------|-----------|
| $K\Omega$ | Kiloohm   |
| $\mu V$   | microvolt |

## ABSTRAK

Kecederaan Otak Trauma adalah sejenis kerosakan otak yang disebabkan oleh pukulan atau tamparan kepada Kepala, dari trauma tumpul atau tajam. Ia adalah bukan degeneratif, mencari bukan kongenital ke otak yang membawa kepada kemerosotan sementara atau kekal fungsi kognitif, fizikal dan psikososial, dengan negeri yang berkaitan dikurangkan atau diubah kesedaran. ayunan neural adalah mekanisme asas dan penting yang membolehkan penyegerakan aktiviti neural mencari dan dalam kawasan otak dan merangsang koordinasi duniawi yang tepat proses neural asas tugas kognitif seperti kognisi, ingatan, persepsi, dan tingkah laku. Tujuan kajian ini adalah untuk menyiasat perubahan neural ayunan ayunan / otak semasa bekerja tugas memori di kalangan peserta yang sihat dan TBI, untuk menyiasat perubahan kependaman dan amplitud N170 dan komponen P300 dalam bekerja pemprosesan memori di kalangan peserta yang sihat dan TBI dan menyetempatan sumber neural aktiviti ingatan kerja dengan menggunakan analisis Beamforming di kalangan peserta yang sihat dan TBI. Kaedah kajian ini dibahagikan kepada tiga fasa; 1) Fasa Recruitment; Di mana para peserta diambil berdasarkan kriteria kemasukan dan pengecualian, 2) Pengumpulan data; MEG dan EEG rakaman dan 3) Analisis Data; ayunan neural (Delta, Theta, Alpha, Beta) dan Amplitud dan Latency untuk P300 dan analisis N170. Keputusan dibahagikan kepada 3 bahagian mengikut objektif. 1) Perubahan dalam Neural Oscillation kalangan peserta TBI dan peserta yang sihat: peserta TBI menunjukkan kuasa jauh lebih tinggi daripada gelombang frekuensi rendah (Delta dan Theta) dan kuasa yang lebih tinggi daripada gelombang (Beta) aktiviti frekuensi tinggi berbanding peserta sihat semasa tugas ingatan kerja . 2) analisis komponen ERP P300 dan N170 Amplitud dan Latency: penemuan anomali di mana peserta TBI menunjukkan keputusan yang lebih baik dari segi Amplitud dan Latency untuk P300 dan N170. 3) Sumber P300 dan N170 terletak di kawasan visual persatuan, deria-motor dan kawasan yang bertanggungjawab untuk

pemrosesan Memory Kerja. Kesimpulannya, walaupun pesakit TBI sederhana telah menunjukkan agak besar attention untuk bekerja tugas ingatan, pemrosesan fungsi kognitif keseluruhan ingatan kerja telah sedikit merosot berbanding rakan mereka, kajian itu perlu ditiru dalam sampel besar pesakit.

## ABSTRACT

Traumatic Brain Injury is a type of brain damage that is caused by a jolt or blow to the head from blunt or penetrating trauma. It is a non-degenerative, non-congenital revile to the brain that leads to temporary or permanent deterioration of cognitive, physical, and psychosocial functions, with an associated diminished or altered state of consciousness. Neural oscillations are basic and important mechanism that enables the synchronization of neural activity across and within brain regions and stimulates the exact temporal coordination of neural processes underlying cognitive tasks such as cognition, memory, perception, and behaviour. The aim of this study is to investigate the changes of neural oscillations/brain oscillation during working memory task among Healthy and TBI participants, to investigate the changes the latency and amplitude of N170 and P300 component in working memory processing among Healthy and TBI participants and to localize the neural sources of working memory activity by using Beamforming analysis among Healthy and TBI participants. The method of this study is divided into three phases; 1) Recruitment phase; Where the participants are recruited based on inclusion and exclusion criteria, 2) Data collection; MEG and EEG recording and 3) Data Analysis; Neural oscillation (Delta, Theta, Alpha, Beta) and Amplitude and Latency of P300 and N170 analysis. The results are divided into 3 parts according to the objectives. 1) Changes in Neural Oscillation among TBI participants and Healthy participants: TBI participants showed significantly higher power of low-frequency wave (Delta and Theta) and higher power of High-frequency wave (Beta) activity compared to Healthy participants during the working memory task. 2) ERP component analysis of P300 and N170 Amplitude and Latency: Anomaly findings where TBI participants showed better results in term of Amplitude and Latency of P300 and N170. 3) The sources of P300 and N170 are located at the visual association area, sensory-motor and the area that is responsible for Working Memory processing. In conclusion, even the moderate TBI

patients has shown rather greater attention to working memory task, the overall cognitive function processing of working memory was slightly deteriorated compared to their counterpart, the study will need to be replicated in a large sample of patients.

**Keywords: TBI, Working Memory (WM), Neural Oscillations, ERPs,  
Beamforming analysis**

# CHAPTER 1

## INTRODUCTION

### 1.1 Background of study

#### 1.1.1 Definition of Traumatic Brain Injury (TBI)

Traumatic Brain Injury is a type of brain damage that is caused by a jolt or blow to the head from blunt or penetrating trauma (Horne & Kachman, 2018). There are numerous operational definitions of TBI depending on the studies, but it is commonly defined as an alteration in brain functioning or the emergence of evidence of brain pathology caused by an external force (Leo & McCrea, 2016). TBI is a non-degenerative, non-congenital revile to the brain that lead to temporary or permanent deterioration of cognitive, physical, and psychosocial functions, with an associated diminished or altered state of consciousness (Dawodu, 2017).

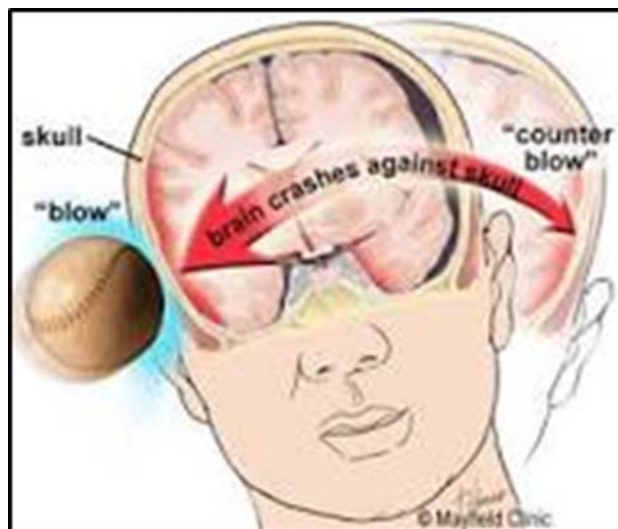

Figure 1.1 A representation of jolt or blow to the head (From: Mayfield Clinic)

The common engender of TBI are traffic accidents, sports injuries, falls and assaults that can happen at home, public area or workplace. The impairments of the brain can be classified into three categories that are mild, moderate and severe, depending on the severity and the mechanism of the injury. According to (Harvey & Close, 2012) the majority cases of TBI hospitalizations were due to falls (82.9%), followed by traffic accidents (9.6%). But the soaring rate in hospitalizations due to TBI is predominantly being driven by the increase in fall-related traumatic head injuries.

### **1.1.2 Epidemiology of TBI**

National Trauma Database 2009 is the fourth report that provides statistical and descriptive analysis of major trauma patients who were referred and admitted to eight participating hospitals in Malaysia. All the data are derived from National Trauma Database (NTrD), a database that is supported by the Ministry of Health (MOH) in collecting information of Malaysia's major trauma incidents and its risk factors, and management. The eight participating hospitals are Selayang Hospital, Kuala Lumpur Hospital, Sultanah Bahiyah Hospital, Pulau Pinang Hospital, Sultanah Aminah Hospital, Sungai Buloh Hospital, Tengku Ampuan Rahimah Hospital and lastly Hospital Ampang. The data collections are conducted by these hospitals' Emergency and Trauma Department (ETD).

Based on the report, 166 768 trauma patients were admitted to the ETD from the 8 participating hospitals in 2009. Major trauma patients decree 1.2% (2061/166 768) of all trauma admissions. Assigned to gender, 86.6% of major trauma patients were males followed by 13.4% females. 15 to 34-year-old individual was at the highest risk of major trauma. Out of 2061 major trauma cases, 52.9% were Malays and 12.9% involved foreigners. The injuries were predominantly from blunt trauma (96.3%). 91.2% of the injuries were accidental with the most cases were due to traffic accidents. Motorcyclists were leading the chart of traffic accidents where it accounted with 66.0%,



followed by injuries that occurred at home with 6.8% and 5.0% happened at construction/industrial place.

Table 1.1 Data tabulation of Major Trauma cases by Gender

| Gender | No. of patients | Percentage (%) |
|--------|-----------------|----------------|
| Male   | 1784            | 86.56          |
| Female | 277             | 13.44          |

(Source: NTrD 4th report 2019)

Table 1.2 Data tabulation of Major Trauma Cases by Age Group

| Age Group | No. of patients | Percentage (%) |
|-----------|-----------------|----------------|
| 15-24     | 703             | 34.11          |
| 25-34     | 464             | 22.51          |
| 35-44     | 271             | 13.15          |
| 45-54     | 173             | 8.39           |
| 55-64     | 146             | 7.08           |
| 65-74     | 87              | 4.22           |

(Source: NTrD 4th report 2019)

Table 1.3 Data tabulation of Major Trauma Cases by Race

| Race      | No. of patients | Percentage (%) |
|-----------|-----------------|----------------|
| Malay     | 1088            | 52.79          |
| Chinese   | 395             | 19.17          |
| Indian    | 272             | 13.2           |
| Foreigner | 266             | 12.91          |

(Source: NTrD 4th report 2019)

Table 1.4 Major Trauma Cases by Cause of Injury

| Cause of Injury                                     | No. of patients | Percentage (%) |
|---|-----------------|----------------|
| Road Traffic  | 1582            | 76.76          |
| Industrial Accident                                 | 26              | 1.26           |
| Fall from over 2 meters                             | 148             | 7.18           |
| Fall from under 2 meters<br>(about a door's height) | 95              | 4.61           |
| Sports Injury                                       | 6               | 0.29           |
| Burns   | 19              | 0.92           |
| Stab Wounds   | 36              | 1.75           |
| Gunshot Wound                                       | 4               | 0.19           |
| Other Assault                                       | 83              | 4.03           |

(Source: NTrD 4th report 2019)

Table 1.5 Major Trauma Cases by Glasgow Coma Scale (GCS)

| Glasgow Coma Scale (GCS) | No. of patients | Percentage (%) |
|--------------------------|-----------------|----------------|
| 13-15                    | 625             | 30.33          |
| 9-12                     | 410             | 19.89          |
| 3-8                      | 1026            | 49.78          |

(Source: NTrD 4th report 2019)

### 1.1.3 Classification of TBI

(Silver *et al.*, 2005) There are two classification of TBI; one is primary and secondary Injuries and another one is Focal and diffuse injuries. (1) Primary and Secondary Injuries; Primary injuries are caused by mechanical force and happens right at the moment of impact; the two main mechanisms of primary injury are contact such as object hit the head, or the brain hit the inside of the skull and acceleration-deceleration. Secondary injuries are not externally induced, may be delayed from the moment of impact and it may superimpose injury on a brain that already induced by primary Injury.

(2) Focal and diffuse injuries; This category of injuries is commonly detected together. Focal injuries comprise of scalp injury, skull fracture and surface contusions, it is generally caused by contact. Diffuse injuries in other hand includes diffuse axonal injury (DAI), hypoxic-ischemic damage, meningitis, and vascular injury which are generally caused by acceleration-deceleration forces.

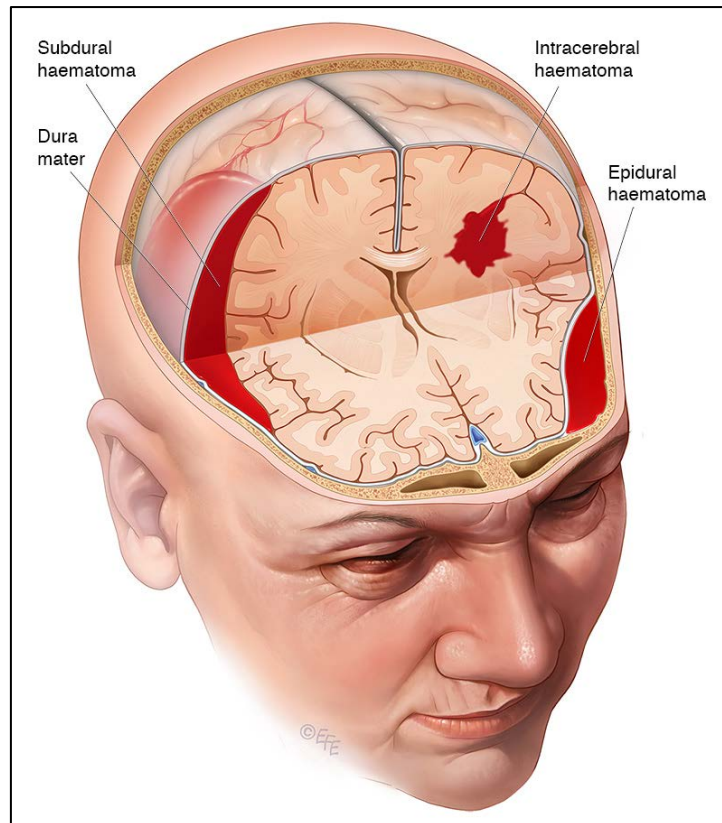

Figure 1.2 Graphic representation of brain damage that may occur inside of TBI patient.

#### 1.1.4 Severity measurement of TBI

(Pangilinan *et al.*, 2019) Glasgow Coma Scale (GCS) is used to measure the severity of TBI, it tested the level of consciousness in a patient based on several categories of test. The categories are divided into three categories; Eye Opening (E) that consist of scores ranging from NT (Not testable) to spontaneous (4), the higher the score the better the condition of the patient. (2) Verbal response (V), the second test that consist scores ranging from none (1) to obeys command (6); Lower score indicates poor consciousness while high score indicates the opposite.

The last test category is the Motor Response (M), where the score comprises of NT to obeys command (6). At the end of the test, the marks from each category will be summed up, the summation score will be used in the classification of TBI. GCS score that is 8 or less indicates severe TBI, followed with score ranging from 9 to 12 indicates moderate TBI and lastly the mild TBI with GCS score of 13-15.

### **1.1.5 Symptoms and effects of TBI**

Symptoms of TBI may be asymptomatic for a few days or weeks following the injury ("Traumatic Brain Injury, "). Symptoms of TBI varies according to the severity of the injury, and the symptoms can be physically shown or cognitively. For mild TBI patients, their physical symptoms will be as losing consciousness for a short time, headache, being in state of confusion, dizziness, blurred vision or tired eyes, ringing in the ears and lastly having a bad taste in mouth. Mild TBI patients may have damage in their cognitive systems resulting in excessive fatiguenesss or feeling lethargic, changed in sleeping patterns, behavioural or mood alteration and having difficulties in task that involves memorizing, concentration, attention, or thinking ("What are the Causes of TBI?, "). Mild TBI can be a temporary injury to the brain while worse TBI can result in torn tissues, bruising, bleeding and other physical damage to the brain. These injuries can cause long-term complications and even can be fatal ("Traumatic brain injury, ").

("Traumatic brain injury, ") Moderate or severe TBI patients might show the same symptoms as mild TBI and occurs within the first hours to days after the head injury. Patients will be having a loss of consciousness in a longer time from several minutes to hours. The symptoms will go to repeatedly vomiting and keep feeling nauseated, the individual may also experience convulsions or seizures. Dilation of one or both pupils of the eyes, runny nose and/or ears, unable to wake up from sleeping, weaken and/or numb fingers and toes and losing coordination. Patients will be having mental or cognitive issues such as profound confusion, feeling frequent agitated, slurred speech and might be in coma or any other consciousness disorders.

(Stuss, 2011) In most cases of TBI, frontal or temporal areas are predominantly affected despite the mechanism of injury and subsequent pathophysiology. Since frontal and temporal region are responsible of cognitively demanding tasks including executive control, working memory, episodic memory and problem solving as well as

the processing speed, it may result in inefficiency of those activities in a brain of TBI patient.

| Lobe           | Normal brain  | Injured brain  |
|----------------|---|--|
| Frontal lobe   | Personality, behavior, emotions<br>Judgment, planning, problem solving<br>Speech: speaking and writing (Broca's area)<br>Body movement (motor strip)<br>Intelligence, concentration, self awareness | Behavioral and emotional changes<br>Impaired judgment, motivation and inhibition<br>Reduced mental abilities, memory loss<br>Impaired sense of smell, vision loss<br>Paralysis on one side of the body   |
| Parietal lobe  | Interprets language, words<br>Sense of touch, pain, temperature<br>Interprets vision, hearing, motor, memory<br>Spatial and visual perception   | Difficulty distinguishing left from right<br>Lack of awareness or neglect of certain body parts<br>Difficulties with eye-hand coordination<br>Problems with reading, writing, drawing, naming, mathematics   |
| Occipital lobe | Interprets vision (color, light, movement)  | Defects in vision or blind spots (visual field cuts)<br>Blurred vision, visual illusions / hallucinations<br>Difficulty reading and writing  |
| Temporal lobe  | Understanding language (Wernicke's area)<br>Memory<br>Hearing<br>Sequencing and organization  | Problems with short-term and long-term memory<br>Changes in sexual behavior<br>Increased aggressive behavior<br>Difficulty recognizing faces, identifying / naming objects<br>Difficulty understanding language and speaking (aphasia)<br>Common location for seizures |
| Cerebellum     | Balance<br>Coordination<br>Posture  | Difficulty coordinating fine movements<br>Difficulty walking, tremors, dizziness (vertigo)<br>Slurred speech   |
| Brainstem      | Automatic functions such as breathing, heart rate, body temperature, wake and sleep cycles, digestion, sneezing, coughing, vomiting, and swallowing   | Changes in breathing<br>Difficulty swallowing food and water (dysphagia)<br>Problems with balance and movement<br>Dizziness and nausea (vertigo)   |

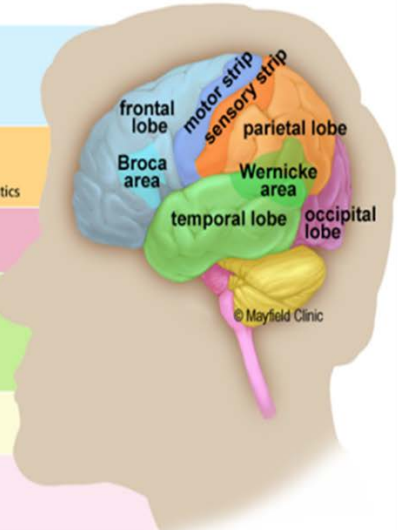

Figure 1.3 The effects of TBI on the brain's lobe (source:Mayfield Clinic)

## 1.2 Neural oscillation/Brain Oscillation

### 1.2.1 Definition of Neural Oscillation

Neural oscillations or brainwaves are rhythmic or monotonous patterns of neural activity in the central nervous system (CNS) ("Neural Oscillations," 2016). According to Başar, 2013 neural oscillations refer to the rhythmic and/or repetitive electrical activity that is being generated spontaneously as a response to stimuli by neural tissue in the CNS. Hans Berger (1873-1941) discovered the neural oscillation process by using electroencephalogram. The role of this process is as functional building blocks in sensory-cognitive processes has been proved to be significant in recent decades (Başar, 2013).

Neural oscillations are basic and important mechanism that enables the synchronization of neural activity across and within brain regions and stimulates the exact temporal coordination of neural processes underlying cognitive task such as cognition, memory, perception, and behavior

(Neustadter *et al.*, 2016). It is an emergent property of neural networks generated by coordinated synaptic transmission across neuronal populations (Ford *et al.*, 2007). Neural oscillations also functioning as a putative mechanism for sensory, attentional, mnemonic, and motoric processes (Singer, 1999; Başar, 2011). Synchronization of neural oscillations might be reflecting variable signals underlying communication flexibility within and between cortical areas (Uhlhaas, 2011).

### **1.2.2 Classification of Neural Oscillation**

Neural Oscillations are classified according to their frequency, amplitude and phase. There are two types of neural oscillations; Evoked neural oscillations where phases are locked to the stimulus onset and another one is induced neural oscillation which is not strictly locked to the stimulus onset but are related to the stimulus (Başar, 2013).

Oscillation will occur whenever neurons fire repetitively in synchronization at a specific period. The number of firing represent the frequency of the oscillation, 1 Hertz (1 Hz) indicates one oscillation per second. Inside the brain of impaired cognitive patients, event-related oscillations (ERO) in the alpha, beta, gamma, delta, and theta frequency are highly modified.

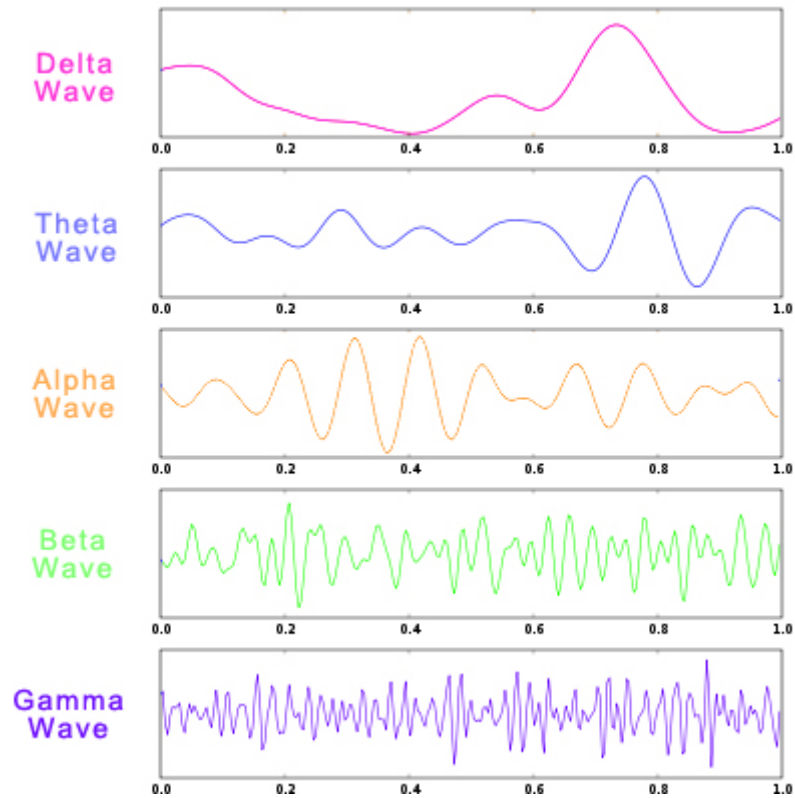

Figure 1.4 Brainwaves and its ranges

(Source: Traumatic Brain Injury Rehabilitation)

### 1.3 Working Memory and N-back task

#### 1.3.1 Working Memory (WM)

Working memory is the ability of an individual to hold information shortly in the memory while executing other mental operations on the information (Mirsky *et al.*, 1995). It is a process of maintaining and manipulating information for instant use without letting the information being encoded into short or long-term memory storage. It is a process of keeping information consciously in mind whilst transforming it to execute something in achieving certain goal. Executive function disorders are often being connected to the deficits in working memory (Bowler & Lezak, 2015).

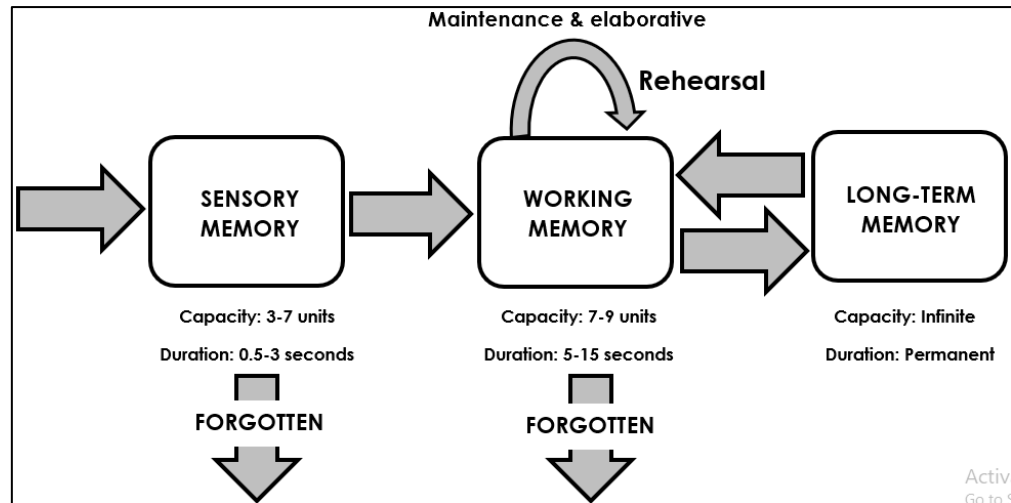

Figure 1.5 Working memory model by Allen Baddeley

Allen Baddeley a psychologist who is working on the memory system, proposed that the initial stages of the memory system are complex. He promoted that conscious activation of information is important for human ability to understand thought and perception; only then the information is transferred and permanently stored into long-term memory (Baddeley, 2007). Figure 2.5 shows the flow on how the information is being process starting from the stimulus until it being encoded and stored in the long-term memory storage. First, sensory memory will pick up stimulus and last for 0.5 to 3 seconds. When the person started to be attentive to the information, the working memory will retain the information approximately for 5 to 15 seconds even without being rehearsed. If the information is being left without rehearsed or used it will be forgotten while if the information I repeatedly access it will be encoded and transferred to the long-term memory.

### 1.3.2 N-back

N-back test was developed by Wayne Kirchner in 1958 as a measuring tool for working memory, it was originally introduced as a visuospatial task with four load factors ("0-back" to "3-back") (Coulacoglou & Saklofske, 2017). A year after, Mackworth then introduced N-back task as a visual letter task with up to



six load factors (Coulacoglou & Saklofske, 2017). N-back task is a continuous-recognition measures that present stimulus sequences in order whether in form of letters or pictures. When the stimuli match what is shown 'n' steps before, the subject will press the 'stop' button (Owen *et al.*, 2005). The number 'n' will increase, means that more memory will be needed as the game progress.

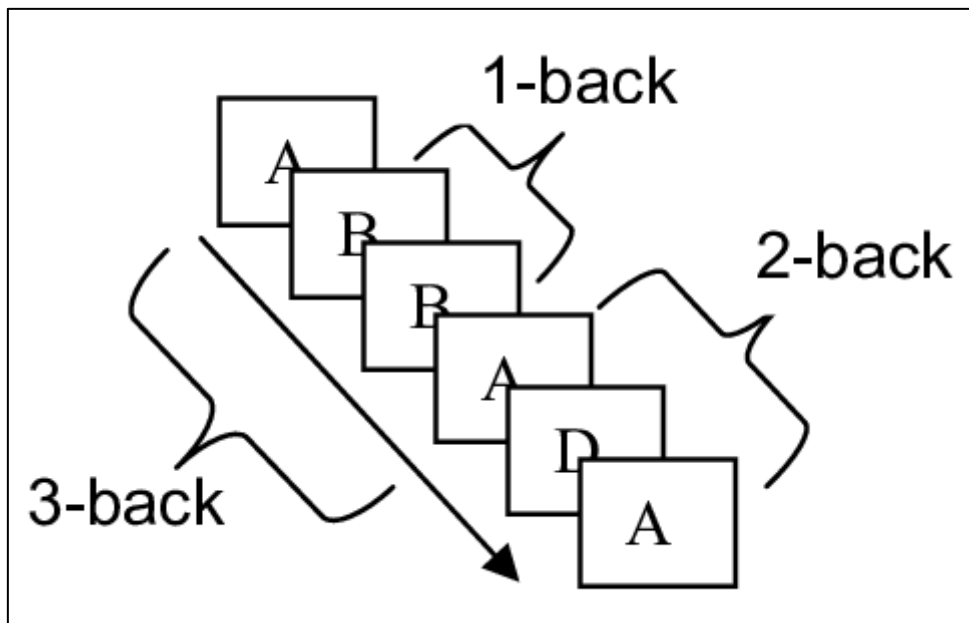

Figure 1.6 Example of graphical representation of 1, 2 and 3 n conditions in N-back paradigm with letter as a stimulus

This exercise will challenge the active part of the participants' working memory. Once subject has pass  $N = 1$ , the representation will be more complex and not the simple and recent items on your mind. Updated stimulus that will make the participants' mind 'buffer' and able to compare new input against the one that the participants remember. This activity requires maintenance and manipulation of working memory (Owen *et al.*, 2005).

The neurobiology of N-back test that is the most popular experimental paradigms for functional neuroimaging studies of working memory is that, when the test is conducted, some regions in the brain are found to be activated by using neuroimaging. Cortical region, lateral premotor cortex, dorsal cingulate and medial premotor cortex, dorsolateral and ventrolateral prefrontal cortex;

frontal poles, and medial and lateral posterior parietal cortex (Owen *et al.*, 2005). Subsidiary meta-analyses based on suitable subsets of the primary data demonstrated wide range of similar activation patterns for identity monitoring of verbal stimuli and both location and identity monitoring of nonverbal stimuli (Owen *et al.*, 2005).

## **1.4 EEG/MEG/ERP**

### **1.4.1 EEG**

EEG is an abbreviation of Electroencephalogram, a tool to record electrical activity in the brain by using electrodes attached to a person's scalp ("EEG (electroencephalogram)"). Neurons in the brain communicates with each other in an electrical form even in a sleeping state. This activity will be recorded by EEG machine and conveyed as wavy lines on the computer. EEG is widely used for research purpose and clinical diagnose. Changes in brain activity may indicates brain damage or disorder that related brain. In this research we are conducting EEG to determine the differences of brainwaves in TBI patients and normal subject.

EEG is also used to detect disease such as brain tumour, brain dysfunction, inflammation in the brain, stroke or sleep disorders. For patients that are in vegetative state EEG will be used to confirm brain death. Rather than confirming brain death, it also helps to determine the right level of anesthesia for patient that in medically induced coma. Subject may feel a slightly uncomfortable during the EEG session as the need to follow a few rules and guideline. However, the electrodes do not give any sensation to the subject it only records the brain wave.

Nowadays, the used of EEG in context of human-machine interaction has become tremendously popular (Frey *et al.*, 2013). Many studies are also been using EEG to measure mental states focus on specific task like working memory (Klimesch, 1999) or affective valence (Ahern & Schwartz, 1985).

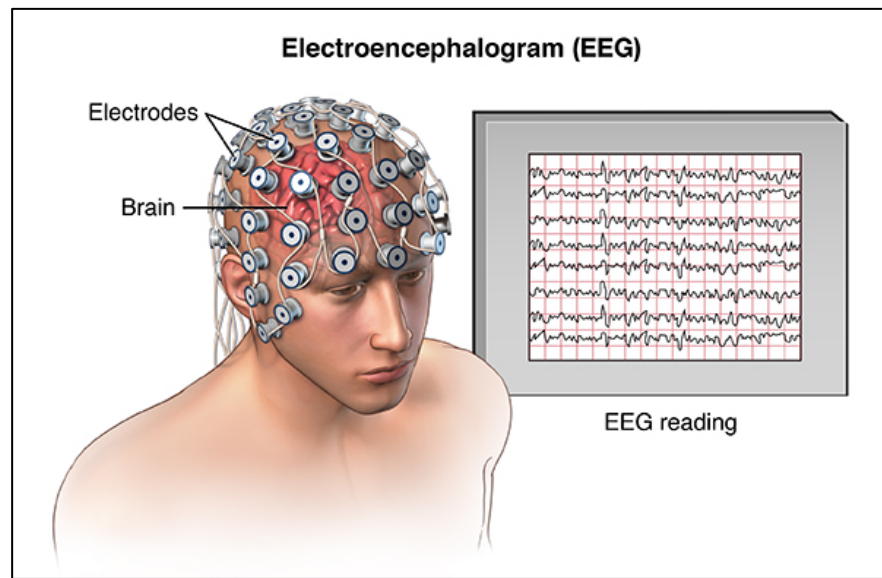

Figure 1.7 Illustration on how the electrodes and the EEG output will be conveyed during EEG session

#### 1.4.2 MEG

MEG or Magnetoencephalography is a tool to measure magnetic field that is generated by the electrical activity of neurons in the brain (Singh, 2014). MEG is a non-invasive test that provides precise resolution of the timing of neuronal activity (Singh, 2014). It's a direct measure of brain function with a very high temporal resolution and a good spatial resolution. MEG usage is usually paired with magnetic resonance imaging (MRI) to get an excellent structural perspective. The combination of MEG and MRI are called Magnetic source imaging (MSI).

Magnetic fields that are recorded by MEG are generated by the electric current in the brain. Thus, it is extremely important for MEG to be housed inside a magnetically shield room to ensure the external magnetic noises are attenuated. Magnetometers and gradiometers are the sensors that are responsible to record the magnetic field; there are two types of gradiometers that are axial and planar. Magnetometers are most sensitive to deep brain sources and provide the best signal. However, magnetometers are also sensitive to other magnetic noises when gradiometers are better at noise reduction. One of the most crucial advantage of MEG over EEG, is that MEG fields pass through the head without any distortion and it has high spatial and temporal resolution.

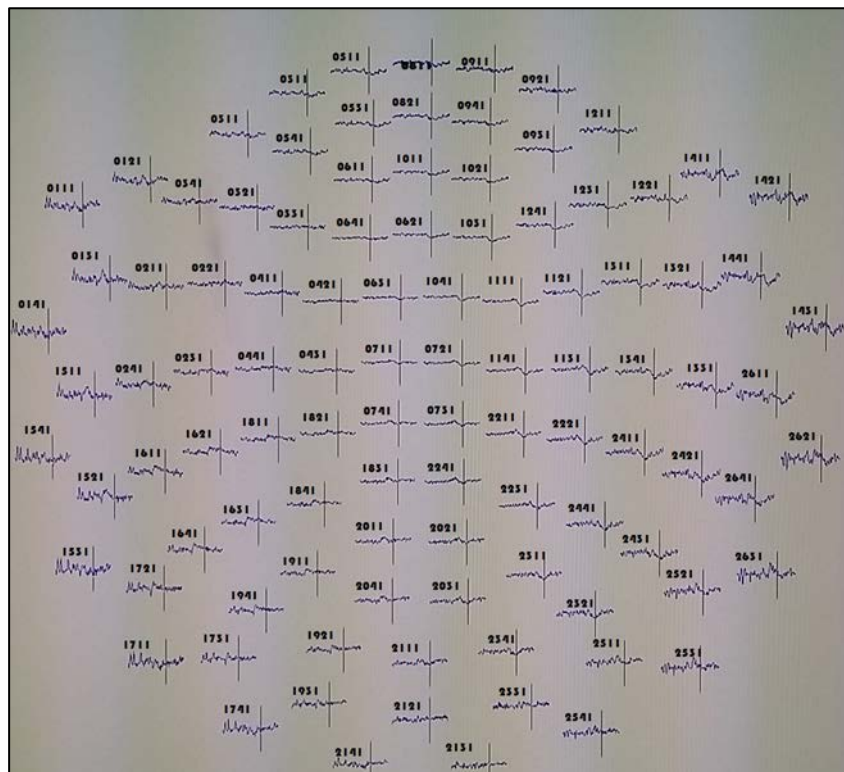

Figure 1.8 Example of MEG recording

### 1.4.3 ERP

Event-related potential (ERP): The measured brain response resulting directly from a specific sensory, cognitive, or motor event (Başar, 2013). According to Rugg, 2001 ERP is a voltage fluctuation that are being recorded proportional to a specific time and event. It is a measured brain response that is the direct result of a specific sensory, cognitive or motor event (Luck, 2005). ERPs are very small voltages produced in the brain as a response to specific events or stimuli (Blackwood & Muir, 1990)

ERP is thought as a reflection of the summed activity of postsynaptic potentials produced when a large number of neurons synchronously fire together while processing information (Peterson *et al.*, 1995). (Sur & Sinha, 2009) In human, ERP can be divided into two categories; The early waves, the components that peaking within the first 100 ms after stimulus being projected and are termed as 'sensory' or 'exogenous' as they depend largely on physical parameters of the stimulus. Second component is the later part in which participant will be evaluating the stimulus and the waveform formed due to that is called 'cognitive' or 'endogenous'. The waveforms are described according to latency and amplitude.

Previous studies on ERP showed that latency and amplitude of some of the TBI patients were abnormal compared with control groups (Larson *et al.*, 2007; Segalowitz *et al.*, 1997). (Rugg, 2001) Since ERP is just a small part of electrical activity of EEG that are not time-locked to any specific event, it is necessary to perform processing techniques that can extract ERP 'signal' from the noise in which it's embedded. Signal averaging is the most commonly employed technique where a number of EEG segments, each time-locked to the same event are averaged and giving out a waveform in which consistent features of the segments are retained while others are reduced.

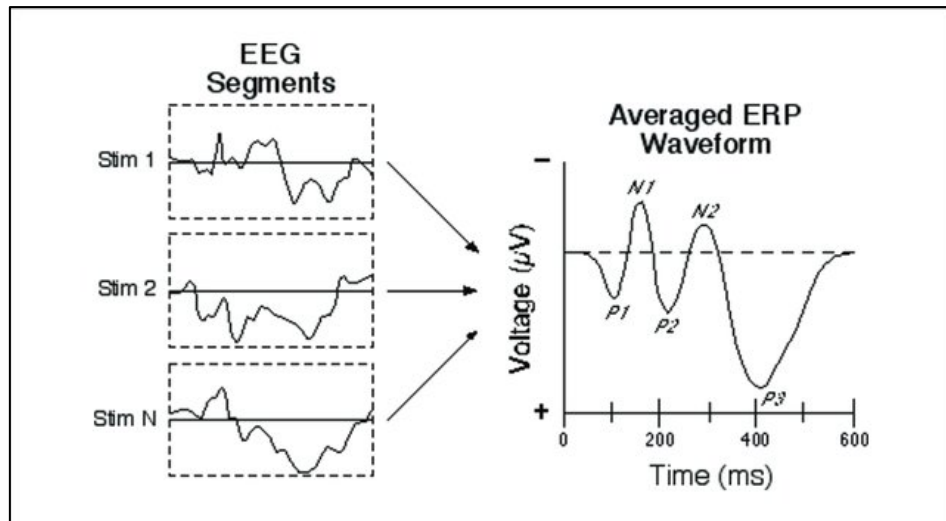

Figure 1.9 Example of the averaging process of EEG segments to produce ERP (Léger., 2014)

#### 1.4.3.1 P300

P300 or P3 wave was discovered by Sutton *et al.* in 1965 and has been the major component of ERP research field (Polich, 2007). It is a positive deflection (Picton, 1992) in voltage with a latency (delay between stimulus and response) of approximately 250 to 500 ms (Bentin *et al.*, 1996). P300 wave is considered to be an endogenous potential, as its occurrence links more to a person's reaction rather than physical attributes of a stimulus. Latency is the speed of stimulus classification resulting from discrimination of one event from another (Sur & Sinha, 2009). Superior mental performance will give out shorter latencies (Sur & Sinha, 2009).

P3 amplitude is the reflection of stimulus information, greater attention produced larger P3 wave (Sur & Sinha, 2009). Numerous studies have been conducted to elicit the P3 wave, this is when Oddball paradigm was discovered and widely applied. In this paradigm, subject will be instructed to respond to a rare or infrequent occurrence rather than the frequently presented stimuli (Başar, 2013). Declined in P3

wave indicates neurobiological vulnerability that underlying disorders such as alcohol dependence, drug dependence, nicotine dependence, conduct behaviour and adult anti-social behaviour (Patrick *et al.*, 2006).

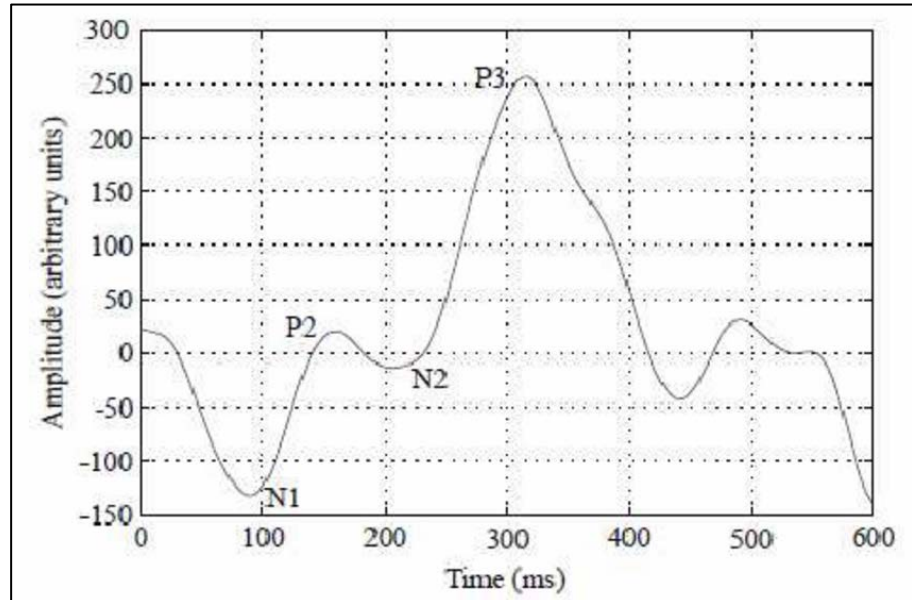

Figure 1.10 Example of P300 wave (Hoffman *et al.*, 2008).

#### 1.4.3.2 N170

N170 is a component of ERP that reflects the neural processing of faces. It was first described by Shlomo Bentin and his colleagues in 1996, they measured ERPs from participants viewing faces and other objects and found that human faces and its parts elicited different responses compare to other stimuli including body parts, cars and animal faces (Kropotov, 2016). The N170 modulation is predominant in the left hemisphere for words and in the right hemisphere for faces (Ibanez *et al.*, 2011).

In adults, N170 is a face-sensitive ERP component is a negative deflection in wave amplitude that produced around 170 ms after the presentation of a face (Bentin *et al.*, 1996; George *et al.*, 1996).

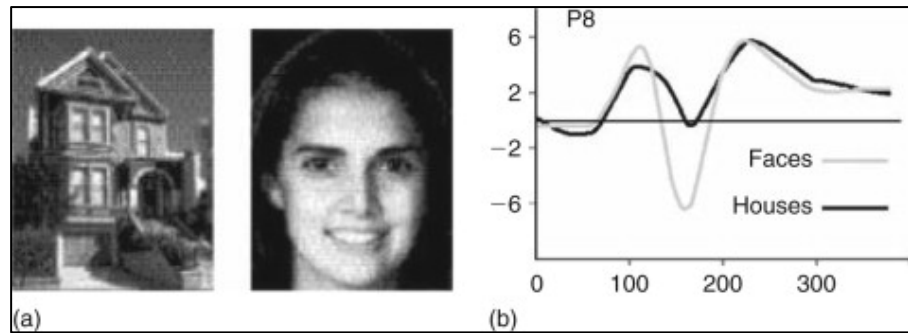

Figure 1.11 The N170 fluctuated downwards with a greater amplitude when the stimuli are a face (Kropotov, 2009)

### 1.5 Beamforming Analysis

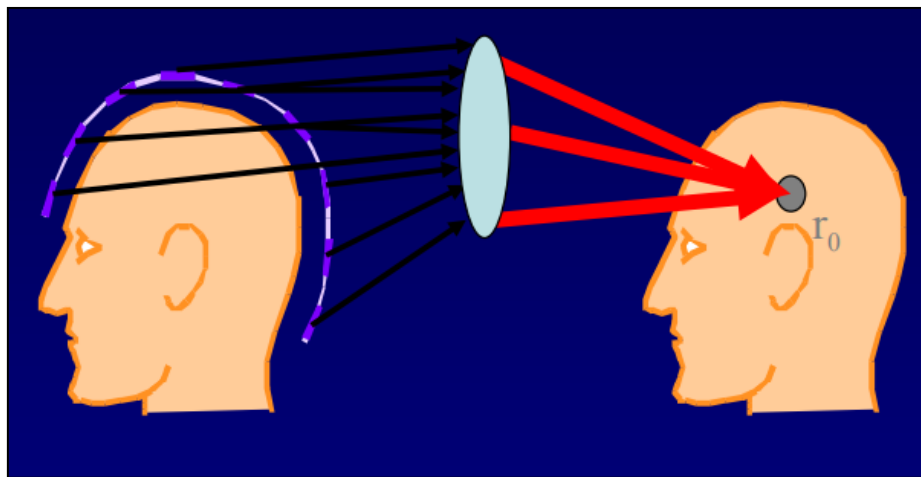

Figure 1.12 Illustration on the idea of beamforming approach (Sillekens *et al.*, 2008)

Beamforming approach is a spatial-filtering based source reconstruction method for MEG and EEG that allows the estimation of neuronal activity at a particular location within the brain (Oswal *et al.*, 2014). According to Ashiwini Oswal, accurate estimation of both the lead fields and the data covariance is important for accurate beamformer solutions. In addition, they discussed about the accuracy of covariance matrix estimation which, might counterintuitively, is inversely proportional to the number of channels (Brookes *et al.*, 2008). MEG data usually been used for source localization in beamformer method (Woolrich *et al.*, 2011). Main key to beamformer analysis is the estimation of the data covariance matrix (Woolrich *et al.*, 2011).



If the level of the noise is high, or only small amount of data is available it will be resulted in poor estimation of data covariance matrix and degraded signal-to-noise ratio of the beamformer output (Woolrich *et al.*, 2011). One of the crucial advantages of this analysis is that induced changes in cortical oscillatory power that is absence in a strong average-evoked response still can be identified and localized (Hillebrand & Barnes, 2005).

## **1.6 Objective(s)**

### **1.6.1 General Objective**

To study the neural processing and to localize the sources during N-back Working Memory task from EEG and MEG data among Healthy and TBI participants.

### **1.6.2 Specific Objectives**

- 1) To investigate the changes of neural oscillations/brain oscillation during working memory task among Healthy and TBI participants.
- 2) To investigate the changes the latency and amplitude of N170 and P300 component in working memory processing among Healthy and TBI participants.
- 3) To localize the neural sources of working memory activity by using Beamforming analysis among Healthy and TBI participants.

## **1.7 Hypothesis**

### **1.7.1 Null Hypothesis**

- 1) There are no differences in neural oscillation during Working Memory task between TBI and Healthy participants
- 2) There are no differences in the latency and amplitude of N170 and P300 components between TBI patients and Healthy participants
- 3) There are no neural sources present at the frontal or temporal lobe.

### **1.7.2 Research Hypothesis**

- 1) There are differences in neural oscillation during Working Memory task between TBI and Healthy participants
- 2) There are differences in the latency and amplitude of N170 and P300 components between TBI patients and Healthy participants
- 3) There are neural sources present at the frontal or temporal lobe.

## **1.8 Rationale of Study**

This study is being conducted to examine the pattern of functional neural changes in the brain and the exact location. There might be a difference in the performance between healthy and TBI patients as it is proven in the past research. The sources localization of the affected area related to working memory may be identified, as TBI patients are believed to have declined progress on their working memory ability and specific area in the brain might be responsible to this. The knowledge of the exact neuronal sources could be beneficial for the therapeutic/rehabilitation purpose and improve the working memory ability.

## CHAPTER 2

### LITERATURE REVIEW

#### 2.1 Neural Oscillations during Working Memory

In a review study conducted by Sun *et al.*, 2017 Oscillatory Alpha activity and ERPs from EEG provides evidence that helps to elicit specific impairments in TBI patients. From the review, acute EEG changes in mild TBI patients were identified; where quantitative EEG (qEEG) commonly shows reduction in the mean of Alpha frequency (Ilanof & Anghinah, 2017), Increased Delta and increased theta (Fenton, 1996; McClelland *et al.*, 1994) or increased Theta:alpha ratio (Chen *et al.*, 2006; Watson *et al.*, 1995). Subacute EEG changes were also found in mTBI weeks or months after the recovering process; Posterior alpha frequency increased by 1-2 Hz and then return to original baseline in 3 months to a year. For chronic changes in mTBI, high delta (1.5-5 Hz) and low frequency of alpha (8.5 – 12 Hz) were determined post-concussive syndrome patients with matched controls.

Brain oscillations at different frequencies have been associated to numerous of basic and higher cognitive processes. Another review study was conducted to identify the roles of frequencies (Theta, alpha and gamma) during Working Memory maintenance process (Roux & Uhlhaas, 2014). In this study, it was proposed that gamma band is involved during WM maintenance, alpha band is responsible in inhabitation of task-irrelevant information, theta-band underlies the organization of sequentially ordered WM items and the role of cross-frequency coupling (CFC) in enabling alpha-gamma and theta-gamma for different WM information.

A study by Maurer *et al.* was conducted to investigate the relevance of the theory which Increasing of Frontal midline (FM-) Theta activity was associated with WM processes. During the study Maurer *et al.*, found a MEG study that can support the theory. It was a study conducted by Jensen and Tesche in 2002, where Theta did increase with WM complexity during retention. Not only in WM task that associates with visual (Boonstra *et al.*, 2013) but also during Sternberg WM task (Meltzer *et al.*, 2007 and Michels *et al.*, 2008)). These findings also lead to the localization of the theta activity at the frontal and anterior cingulate (Luu *et al.*, 2004). However, in a WM-dependent study conducted by Michels *et al.*, 2008 showed the fm-theta did not increased in 20% of the study's participants; elicit that these effects are variety. They found that fm-Theta increased when WM load is high, and the accuracy of the participants performance decreased. Thus, it was concluded that lesser accuracy reflects increased in WM load. The results in this study is corroborating with the previous study that fm-Theta increment does relate to the complexity of WM. Nevertheless, this evidence only proved the significance of large fm-theta activity during WM process and the increased of fm-theta was only statistically proven at a few frontal electrodes not the average of all electrodes. Besides Theta band, they also detected the involvement of alpha frequency (Increased in high WM, decreased in low WM).

In our study, we decided to investigate the changes of delta, theta, alpha and beta frequencies during the Working Memory task between the moderate TBI and healthy participants.

## **2.2 N170 component in response to single letter perception as the stimulus.**

The N170 modulation is predominant in the left hemisphere for words and in the right hemisphere for faces (Ibanez *et al.*, 2011). A study conducted by (Stevens *et al.*, 2013) found that single letters enhanced N170 more than false font stimuli and elicited a bilateral rather than only left-lateralized. They are using 0-back paradigm with single letters and false fonts as the stimulus and 16 colleague students as their healthy participants. The ERPs of the

participants were recorded, and the result showed that both letters and false fonts evoked N170 with letters induced higher amplitude of N170.

Another study that showed single letters do evoked N170 by the single letter as the stimulus was done by Wong *et al.* in 2005, where they examined the selectivity of the N170 component to single letters associated with expertise (They conducted an experiment on English readers who unable to read Chinese and Chinese-English who are bilinguals). In this study, 0-back task paradigm was applied and presented with three types of stimulus; Roman alphabet, Chinese character and pseudo-font characters. The result showed that N170 was larger when the Roman character was the stimulus across all participants which then they concluded familiar letters enhances higher N170 response. As both groups of participants are familiar with roman characters there might be some relations between familiar stimulus and enhancement of N170. The result was then supported by the statement from another study that stated, personal memory activation is one of the visual N170 wave's attribution that is partly generated in the fusiform gyrus (Kropotov, 2016).

Robotham *et al.*, 2017 conducted a review study entitled "Face and word recognition can be selectively affected by brain injury or developmental disorders", a review about whether face and word recognition rely on highly specialized cognitive processes. In this review study, several research papers that proposed since 2004 onwards were compared. The highlight of this review was that they reviewed the studies that are using N170 component in their study to emphasize the relation of N170 amplitude and words as the stimulus in the research. As proven in previous studies, N170 did enhanced through words as the stimulus, N170 amplitude is larger at the right hemisphere for faces and larger at the left hemisphere for words (Bentin *et al.*, 1996; Schendan *et al.*, 1998). Based on research conducted in 2009 and 2013 by Dien and Nestor *et al.* N170 elicited bilateral activation of the brain hemisphere.

As most of the study conducted revealed that N170 component does response to single letter perception, in our study we decided to compare the N170 component between moderate TBI patients and Healthy group by using single letter as the stimulus too. While most

studies above only used 0-back we decided to use 0-back, 1-back, 2-back and 3-back paradigm to strengthen our justification to see the differences across the groups.

### **2.3 P300 as an electrophysiological cognitive index in TBI patients**

Wong *et al.* in 2005 said that P300 showed smaller amplitude when the participants encountered with familiar stimulus compared to unfamiliar stimulus; such as English and bilingual readers seeing roman character and pseudo-font stimulus. Assumptions was made that probably unfamiliar characters and strings were complex, thus required more attention; this assumption was supported by the statement that P300 amplitude is known to increase proportionally to the stimulus complexity (Johnson, 1986a, 1993b).

P3 amplitude is the reflection of stimulus information, greater attention produced larger P3 wave (Sur & Sinha, 2009). Through ERP study, it has been proved that P300 component is a sensitive index of cognitive efficiency (Larson *et al.*, 2012). In 2007, Doi *et al.* studied the P3 components of ERPs in patients after TBI to evaluate their cognitive attribute. The results showed prolonged visual P300 latency in patients and differences in P300 amplitude of patients and controls; based on that they reported that TBI patients did show declination in cognitive function as reflected by P300 and the reaction time. This paper also discussed about how visual sensory processing may be more complicated and required higher order function, therefore the speed allocation for attention resources that was reflected by visual P300 presumably to be affected (John Polich, 1991). Thus, Polich in 1991 and 2004 suggest that P300 amplitude may be an excellent indicator to determine the effect of attention diversion and time allocation for controls and TBI patients.

Nadia *et al.*, 2012 conducted a study in evaluating the cognitive consequences of mild TBI and concussion by using electrophysiology also P300 as the index to determine cognitive deficits. The main objective of this study was to understand brain performance and function during Working Memory task in mild TBI patients through ERP study and wanted to clarify the association between brain functioning through ERP recording, behavioural performance on