

SULIT



First Semester Examination
2017/2018 Academic Session

January 2018

EAS661 – Advanced Structural Mechanics

Duration : 2 hours

Please check that this examination paper consists of EIGHT (8) pages of printed material before you begin the examination.

Instructions: This paper contains **SIX (6)** questions. Answer **FOUR (4)** questions.

All questions must be answered in English.

Each question **MUST BE** answered on a new page.

...2/-

SULIT

1. (a) Using suitable specialization of basic equations in 3D elasticity, derive the governing differential equation for the linear elastic bar problem shown in **Figure 1** where E : elastic modulus, A : cross-sectional area, w : uniformly distributed load per unit length. Next, using the derived governing differential equation, obtain the expression of axial displacement u and axial stress σ_x for the linear elastic bar problem. Both ends of the bars are fixed.

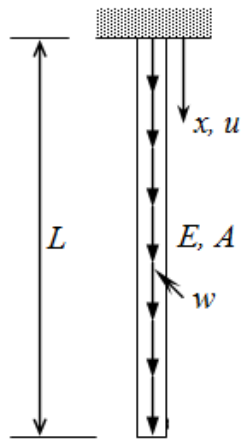

Figure 1

[15 marks]

- (b) **Figure 2** shows a thin plate structure subjected to in-plane (x - y plane) loads on the boundary. The thin plate is also subjected to in-plane body force $R_x(x,y)$ and $R_y(x,y)$ in x and y direction, respectively.

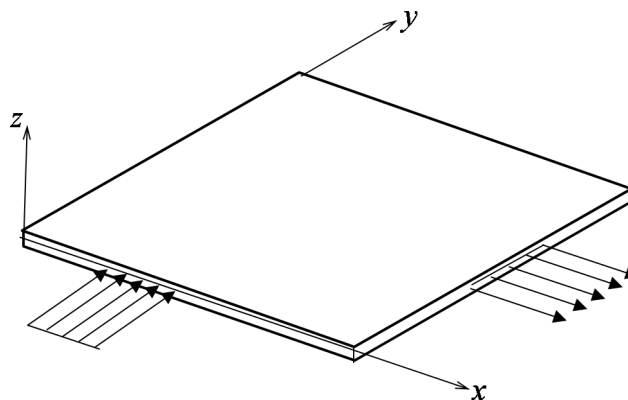

Figure 2

...3/-

- (i) Using a diagram of an infinitesimal volume taken from the interior of the thin plate in **Figure 2**, show clearly the non-zero stress components.
- (ii) Next, using the diagram shown in (i), derive the equilibrium equation in x -direction.

[10 marks]

2. (a) The strain energy U_p stored in an elastic body can be expressed using the following equation:

$$U_p = \int_{vol} v_p d(vol)$$

where v_p is strain energy density. Using the above equation of U_p , derive the equation of strain energy stored in the linear elastic prismatic bar shown in **Figure 3**, where E : elastic modulus, A : cross-sectional area, L : length of the bar and e : elongation of the bar.

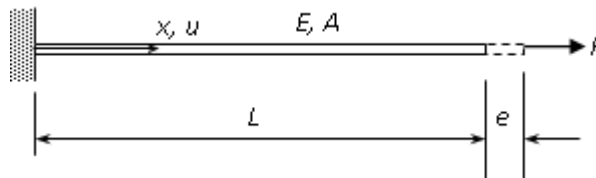

Figure 3

[5 marks]

- (b) **Figure 4** shows a cantilever beam with length l subjected to a uniformly distributed load of intensity w and a vertical point load P at a distance of $\frac{2}{3}l$ from the fixed support. One linear spring with spring constant k is attached to the free end. The following expression for lateral displacement field v has been suggested:

$$v = C_0 \left(1 - \cos \frac{\pi x}{2l} \right)$$

where C_0 is a constant. Show that the above displacement field is kinematically admissible. Next, solve for the constant C_0 by using Rayleigh-Ritz method and principle of minimum potential energy. Flexural rigidity of the column is EI .

...4/-

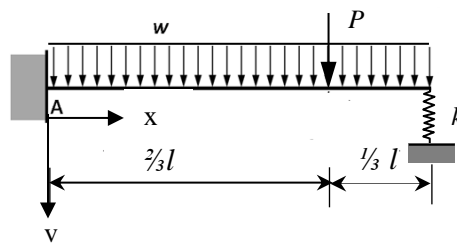

Figure 4

[20 marks]

3. **Figure 5** shows a stepped bar which is fixed at both ends. Length of both portions 1-2 and 2-3 is $0.5L$. Elastic modulus of the bar is E and cross-sectional area of portion 1-2 and 2-3 is A and $1.5A$, respectively. The bar is subjected to a uniformly distributed load w and $1.5w$ per unit length for portion 1-2 and 2-3, respectively. Using piece-wise Rayleigh-Ritz method, obtain the axial displacement at point 2. Divide the bar into two portions 1-2 and 2-3 and assume linear displacement field for each portion.

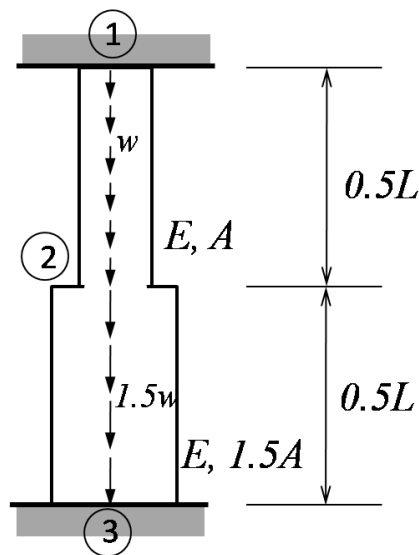

Figure 5

[25 marks]

4. (a) Write down the element stiffness matrices and global matrix for the three bars assembly which is loaded with force P , and constrained at the two ends in terms of E , A and L as shown in **Figure 6a**.

[5 marks]

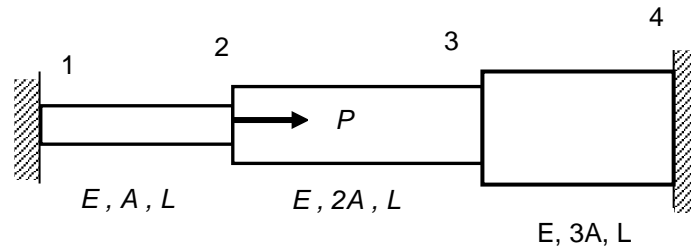

Figure 6a

- (b) Write down the element stiffness matrices and global matrix for the two bars assembly which is loaded with force $10P$ at node 2 as shown in **Figure 6b**. The bar assembly is constrained at end B and free at end A with a gap of Δ at end A. Given the value of $P = 60$ kN, $E = 20$ kN/mm², $L = 200$ mm, $A = 250$ mm² and $\Delta = 1.2$ mm, determine:

- (i) the displacement at nodes 1, 2 and 3
- (ii) the support reaction forces at A

[20 marks]

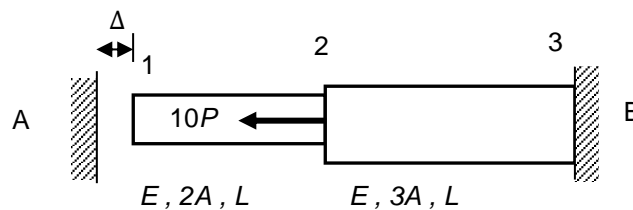

Figure 6b

5. (a) Two plates shown in **Figure 7a** and **7b**, shall be analysed as a plane strain problem. Both plates are divided into 9 elements. Each node has been labelled accordingly. Calculate the bandwidth, $B = (R+1)$ NDOF for the plate assuming two degrees of freedom at each node.

[5 marks]

...6/-

- (b) Rearrange the node labeling in such a way that a minimum value of R is obtained.

[5 marks]

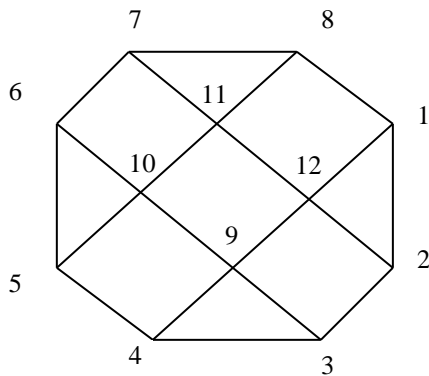

Figure 7a

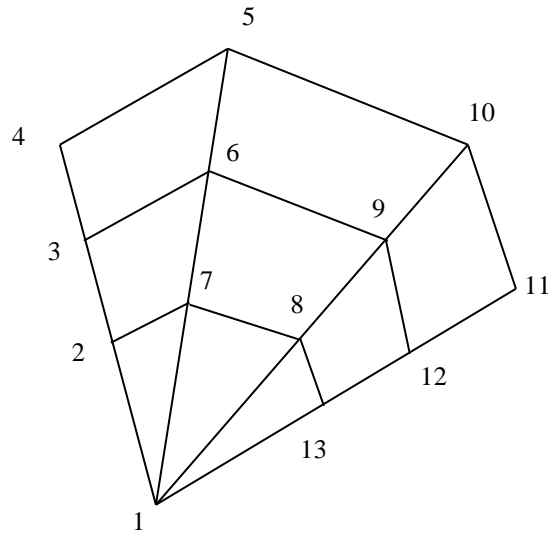

Figure 7b

- (c) **Figure 7c** shows a frame structure labeled as nodes 1, 2 and 3, subjected to a nodal forces of $P = 20 \text{ kN}$ at node 2 and uniformly distributed load of 6 kN/m . The frame is fixed at node 1 and pinned at node 3. Given the value of $E = 207 \text{ GPa}$, $I = 3 \times 10^{-5} \text{ m}^4$ and $A = 0.005 \text{ m}^2$.

- (i) Derive the global stiffness matrix for the frame.
- (ii) Determine the deflection u_2 , v_2 , θ_2 in unit metre and rad, respectively.

[15 marks]

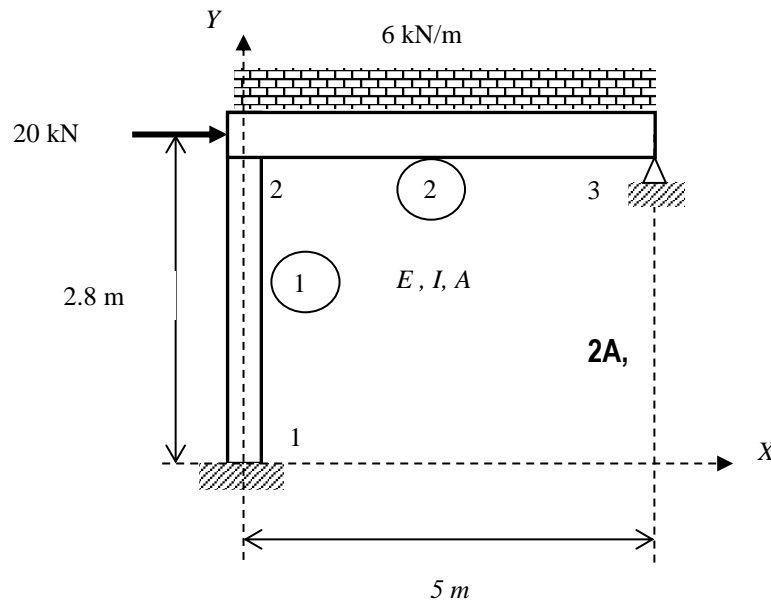

Figure 7c

Given the stiffness of the beam element in dimensional space :

$$k = \frac{EI}{L^3} \begin{bmatrix} v_i & \theta_i & v_j & \theta_j \\ 12 & 6L & -12 & 6L \\ 6L & 4L^2 & -6L & 2L^2 \\ -12 & -6L & 12 & -6L \\ 6L & 2L^2 & -6L & 4L^2 \end{bmatrix} \text{ for the beam element}$$

$$k = \begin{bmatrix} U_i & U_j \\ k & -k \\ -k & k \end{bmatrix} \text{ for the spring element}$$

6. (a) Explain the importance of model validity and accuracy of the following factors in the modeling procedures for Finite Element Method.
- (i) geometry
 - (ii) material properties
 - (iii) loading conditions

[9 marks]

...8/-

- (b) Show clearly in a step by step manner the development process of a stiffness matrix, $[K]^e$, for a triangular element in a state of plane stress as shown in **Figure 8**. Next calculate the displacements at node 3 and node 2. Given $E = 10^3 \text{ kN/m}^2$, $\nu = 0.3$ and $t = 0.5 \text{ m}$.

[16 marks]

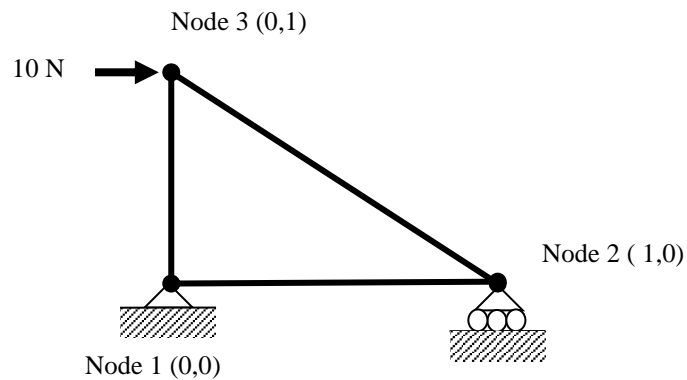

Figure 8

-oooOooo-