



Second Semester Examination
Academic Session 2017/2018

May/June 2018

EMM 242 – Dynamic
[Dinamik]

Duration : 2 hours
[Masa : 2 jam]

Please check that this paper contains **SIX [6]** printed pages before you begin the examination.

*[Sila pastikan bahawa kertas soalan ini mengandungi **ENAM [6]** mukasurat bercetak sebelum anda memulakan peperiksaan.]*

INSTRUCTIONS : Answer **ALL FOUR [4]** questions.
[ARAHAN : Jawab SEMUA EMPAT [4] soalan.]

In the event of any discrepancies, the English version shall be used.

[Sekiranya terdapat sebarang percanggahan pada soalan peperiksaan, versi Bahasa Inggeris hendaklah diguna pakai.]

1. [a] Figure 1[a] shows two different sets of unit vectors. Determine the coordinate transformation array from b_1, b_2 to i, j for the illustrated system.

Rajah 1[a] menunjukkan dua set vektor unit yang berbeza. Tentukan susunan transformasi koordinat daripada b_1, b_2 kepada i, j bagi sistem yang ditunjukkan.

- (i) **Superimpose the two unit vectors and draw the reoriented system.**
Tindih kedua-dua vektor unit dan lukiskan sistem orientasi ulang.
- (ii) **Determine the coordinate transformation array.**
Tentukan susunan transformasi koordinat.
- (iii) **Check the answer by drawing the vectors.**
Semak jawapan dengan melukis vektor-vektor tersebut.

(50 marks/markah)

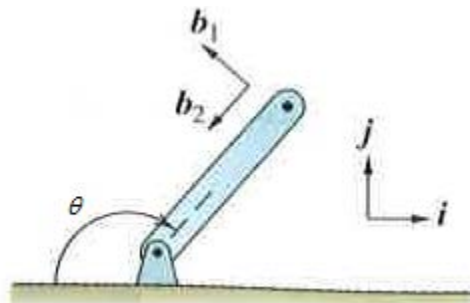

Figure 1[a]
Rajah 1[a]

- [b] Figure 1[b] shows a single-link mechanism. The ends of the link are free to move in straight guides, A along the i direction and B along the j direction. The length of the link AB is 0.5 m. If A is pushed to the right at 4 m/s, determine ICR (instantaneous center of rotation) and v_B when θ is 30° .

Rajah 1[b] menunjukkan mekanisme pautan tunggal. Hujung pautan bergerak bebas pada arah lurus, A pada arah i dan B pada arah j . Panjang pautan AB adalah 0.5 m. Jika A ditolak ke kanan pada 4 m/s, tentukan ICR (pusat seketika putaran) dan v_B apabila θ bersamaan 30° .

(50 marks/markah)

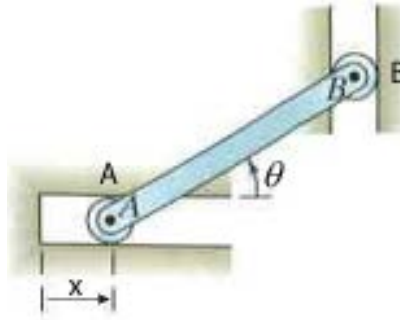

Figure 1[b]
Rajah 1[b]

2. In Figure 2, the saw blade in a lumber mill is required to satisfy these conditions;

Dalam Rajah 2, mata gergaji pada gergaji balak perlu memenuhi syarat-syarat berikut;

- (i) **remain in horizontal position,**
kekalkan pada kedudukan mendatar,
- (ii) **move freely downward and**
bergerak bebas ke bawah dan
- (iii) **undergo a complete back and forth motion.**
melengkapkan gerakan ke depan dan belakang.

An electric motor, having a constant shaft rotation of 50 rad/s, is available to power the saw and can be located anywhere. Design a linkage mechanism that will transfer the rotation of the motor's shaft to the saw blade.

Draw and discuss the details of the design. Determine the maximum velocity and acceleration of the saw blade and indicate the related vectors on the motion path.

Motor elektrik dengan keupayaan putaran malar syaf 50 rad/s disediakan untuk menggerakkan gergaji dan boleh diletakkan di mana-mana. Reka bentuk mekanisme pautan yang memindahkan putaran syaf motor ke mata gergaji.

Lukis dan bincangkan dengan lengkap reka bentuk tersebut. Tentukan halaju maksimum dan pecutan mata gergaji tersebut dan tandakan vektor-vektor berkaitan pada laluan gerakan.

(100 marks/markah)

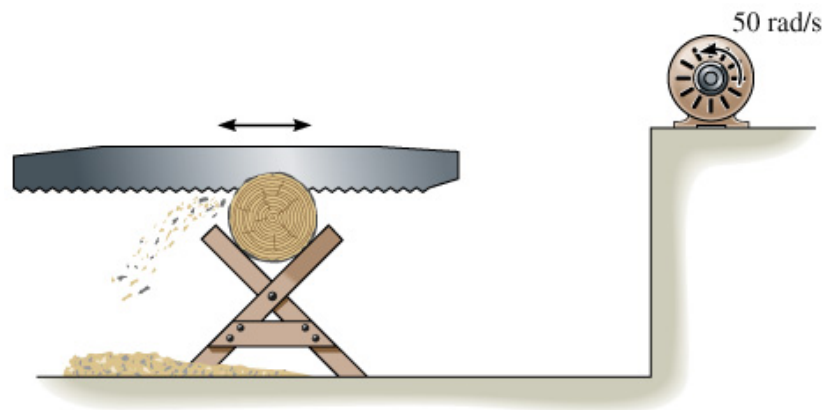

Figure 2
Rajah 2

3. **Figure 3 shows a platform carrying a crate with a centre of gravity at G. The platform is at rest when $\theta = 45^\circ$. The 200kg crate does not slip on the platform. Based on the given information and neglect the mass of the links and the platform,**

Rajah 3 menunjukkan sebuah platform yang membawa kotak dengan pusat graviti pada G. Platform berkenaan berada dalam keadaan rehat apabila $\theta = 45^\circ$. Kotak seberat 200kg itu tidak tergelincir semasa berada di atas platform. Berdasarkan maklumat yang diberi dan abaikan jisim penyambung dan platform,

- (i) **sketch the free body diagram of the platform at θ equals to 45° and 90° , and**
lakarkan rajah badan bebas untuk platform pada sudut 45° dan 90° , dan
- (ii) **determine the force developed in links AB and CD at the instant $\theta = 90^\circ$ if the hydraulic cylinder BE exerts a constant vertical force of $F = 1.5$ kN on the platform.**
tentukan daya pada penyambung-penyambung AB dan CD apabila $\theta = 90^\circ$ jika silinder hidraulik BE mengenakan daya menegak malar $F = 1.5$ kN terhadap platform.

(100 marks/markah)

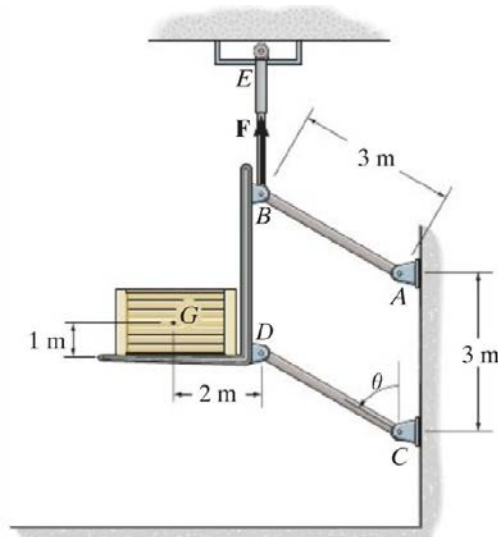

Figure 3
Rajah 3

4. [a] At the instant shown in Figure 4[a], the 25 kg bar rotates clockwise at 2 rad/s. The spring attached to its end always remains vertical due to roller guide at C. If the spring has an unstretched length of 0.6 m and a stiffness of $k = 100 \text{ N/m}$, determine the angular velocity of the bar at the instant it has rotated 30° clockwise.

Pada keadaan seperti Rajah 4[a], bar berjisim 25 kg berputar mengikut arah jam dengan kelajuan 2 rad/s. Spring yang diletakkan pada hujung bar sentiasa berada menegak disebabkan roda pada C. Sekiranya spring mempunyai panjang tidak teregang 0.6 m dan kekakuan $k = 100 \text{ N/m}$, tentukan kelajuan sudut bar pada masa ia berputar pada 30° mengikut arah jam.

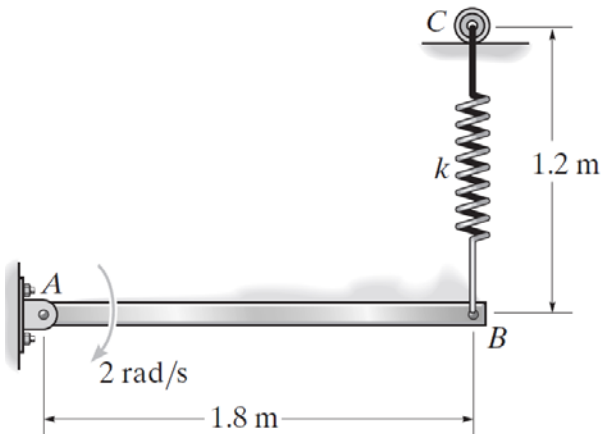

Figure 4[a]
Rajah 4[a]

(40 marks/markah)

- [b] The 5 kg slender rod is suspended from the pin at A as shown in Figure 4[b]. If a 1 kg ball is thrown at the rod and strikes its centre with a velocity of 9 m/s, determine the angular velocity of the rod just after the impact. The coefficient of restitution is $e = 0.4$.

Rod nipis seberat 5 kg digantung pada pin A seperti ditunjukkan pada Rajah 4[b]. Jika bola seberat 1 kg dilemparkan ke arah rod dan mengenai titik tengah rod dengan kelajuan 9 m/s, tentukan kelajuan sudut rod selepas hentaman itu. Pekali pemulihan bagi kes berkenaan ialah $e = 0.4$.

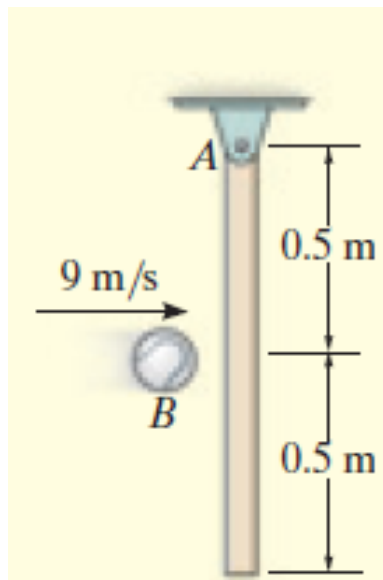

Figure 4[b]
Rajah 4[b]

(60 marks/markah)

-oooOooo-