

**INVESTIGATION OF WATER FLOW OVER CONTRACTED
RECTANGULAR FLAT-CRESTED SLIT WEIR IN OPEN
CHANNEL**

ROSLEY BIN JAAFAR

UNIVERSITI SAINS MALAYSIA

2009

**INVESTIGATION OF WATER FLOW OVER CONTRACTED
RECTANGULAR FLAT-CRESTED SLIT WEIR IN OPEN
CHANNEL**

by

ROSLEY BIN JAAFAR

**Thesis submitted in fulfillment of the
requirements for the degree of
Master of Science**

DECEMBER 2009

ACKNOWLEDGMENTS

In the name of Allah, Most Gracious, Most Merciful.

First I would like to thank Assoc. Prof. Dr. Ishak Bin Hj. Abd. Azid, my advisor for the tremendous guidance and support he has been given me since I started my Master research study at Universiti Sains Malaysia. He is a teacher, scientist and as a friend. It is really a great experience to study with him.

Many thanks must be given to technical staff of School of Mechanical Engineering, Universiti Sains Malaysia for their helpful and cooperative on my research works.

I would also like to express my appreciation to all my friends who gave me an inspiration to work hard and motivated me during my research study.

Special thanks to my wife who has been extremely supportive and patient in putting up with me for all the times and also my kids whom give me a constant love and motivates me indirectly.

I am gratitude to the government of Malaysia and Universiti Teknologi Mara for awarding me the staff study leave. Last but not the least to everyone who helped me in this work for completed my research study.

TABLE OF CONTENTS

	Page
ACKNOWLEDGEMENTS	ii
TABLE OF CONTENTS	iii
LIST OF TABLES	vii
LIST OF FIGURES	viii
LIST OF ABBREVIATIONS	xi
LIST OF SYMBOLS	xii
ABSTRAK	xiv
ABSTRACT	xv
CHAPTER 1 – INTRODUCTION	
1.1 Background	1
1.2 Flow in open channels	1
1.3 Flow measurements in open channels	2
1.3.1 Weirs	4
1.3.1.1 Sharp-crested weirs	7
1.3.1.2 Weirs not sharp-crested	10
1.3.1.3 Selection of weirs	13
1.3.2 Measurement accuracy of the flow	14
1.3.3 Discharge coefficient	15
1.4 Problem statement	16
1.5 Objectives	16
1.6 Outline of dissertation	17

CHAPTER 2 – LITERATURE REVIEW

2.1	Introduction	18
2.2	Flow measurement structure	18
2.3	Rectangular sharp-crested weirs	19
2.4	Weirs not sharp-crested	21
2.5	Remarks on existing study of weir	23
2.6	Summary	26

CHAPTER 3 – THE GENERAL THEORY OF FLOW OVER WEIR

3.1	Introduction	27
3.2	General principles of fluid flow	27
3.2.1	Continuity equation	28
3.2.2	Bernoulli equation	28
3.2.3	Flow through orifices	29
3.2.4	Flow over weirs	32
3.3	General discharge equations for a weir	32
3.3.1	Rectangular sharp-crested weir	34
3.3.2	Rectangular weir not sharp-crested	37
3.3.3	Dimensional analysis	38
3.4	Summary	40

CHAPTER 4 – EXPERIMENTAL INVESTIGATION

4.1	Introduction	41
4.2	Location of head-measurement	42
4.3	Experimental apparatus and facility	45
4.4	Experimental procedure	46
4.5	Summary	48

CHAPTER 5 – RESULTS AND DISCUSSIONS

5.1	Introduction	49
5.2	Experimental result	49
5.2.1	Overview	49
5.2.2	Data collection	50
5.2.3	Weir calibration	52
5.2.4	Head-discharge relationship	56
5.2.5	Discharge coefficient	59
5.2.6	Velocity of approach	62
5.2.7	Weir sensitivity	64
5.3	Error analysis	66
5.3.1	Discharge measurement	66
5.3.2	Head measurement	70
5.4	Equation of discharge coefficient C_d	72
5.4.1	C_d with head	73
5.4.2	C_d with H/b	75

5.4.3	C_d with H/P	77
5.4.4	C_d with H/t	80
5.4.5	C_d with Reynolds number and Weber number	82
5.4.6	Recommendation on an accurate equation	88
5.5	Summary	91

CHAPTER 6 – CONCLUSION

6.1	Conclusion	92
6.2	Recommendation for future study	93

REFERENCES	94
-------------------	----

LIST OF PUBLICATIONS	98
-----------------------------	----

LIST OF TABLES

		Page
Table 4.1	Range of test variables	42
Table 5.1	Data collection of flow over contracted rectangular flat-crested slit weir	51
Table 5.2	Experimental conditions of the collected data	52
Table 5.3	Comparison of values of Q_A and Q_T at $P = 0.04m$	56
Table 5.4	Head-discharge relationship and calculated discharge coefficient for contracted rectangular flat-crested slit weir	57
Table 5.5	Minimum and maximum actual values of weir head and discharge coefficient	61
Table 5.6	Statistical results of actual C_d for contracted rectangular flat-crested slit weir	61
Table 5.7	Comparison of head results due to approach velocity for flow over contracted rectangular flat-crested slit weir	63
Table 5.8	Comparison between actual discharge, calculated discharge and theoretical discharge for contracted rectangular flat-crested slit weir	68
Table 5.9	Statistical results of discharges for contracted rectangular flat-crested slit weir	69
Table 5.10	Comparison value of Reynolds number R , Weber number W and discharge coefficient C_d	87
Table 5.11	Statistical results of comparison of discharge coefficient equation	89

LIST OF FIGURES

	Page	
Figure 1.1	The trapezoidal weir, a sharp-crested weir for flow measurement. (Source: Irrigation water management, training manual no.8, IILRI Italy, 1993)	4
Figure 1.2	Free flow of water over a weir	5
Figure 1.3	Submerged flow of water over a weir.	5
Figure 1.4	Flowing of water over sharp-crested and not sharp-crested weir	7
Figure 1.5	Sketch of contracted rectangular sharp-crested weir	8
Figure 1.6	Sketch of uncontracted rectangular sharp-crested weir	9
Figure 1.7	Sketch of triangular sharp-crested weir	9
Figure 1.8	Sketch of trapezoidal sharp-crested weir	10
Figure 1.9	Flow over a weir not sharp-crested	11
Figure 1.10	Flow over a weir with rectangular cross-section	11
Figure 1.11	Flow over a weir with triangular cross section	11
Figure 1.12	Flow over a weir with rounded entry cross-section	12
Figure 1.13	Flow over a weir with sloping crest cross-section	12
Figure 1.14	Sketch of contracted rectangular flat-crested slit weir	13
Figure 3.1	Components of total head	29
Figure 3.2	An orifice in the side of tank discharging freely to the atmosphere	30
Figure 3.3	Example of opening of orifices	30
Figure 3.4	Flow over uncontracted rectangular sharp-crested weir	34
Figure 4.1	Sketch of contracted rectangular flat-crested slit weir	41
Figure 4.2	Sketch of a top and side view of experimental apparatus	43
Figure 4.3	Sketch of a flow over contracted rectangular flat-crested slit weir	44

...continued

Figure 4.4	View of an experimental apparatus	44
Figure 4.5	Models of contracted rectangular flat-crested slit weir	46
Figure 4.6	View of a flow over contracted rectangular flat-crested slit weir	48
Figure 5.1	Side view of a flow over contracted rectangular flat-crested slit weir	50
Figure 5.2	Plot of $\log Q_A$ against $\log H$ for head-discharge relationship of contracted rectangular flat-crested slit weir	54
Figure 5.3	Actual discharge Q_A plotted against weir head H at $P = 0.04$ m for head-discharge relationship of contracted rectangular flat-crested slit weir	54
Figure 5.4	Actual discharge Q_A plotted against weir head H for head-discharge relationship of contracted rectangular flat-crested slit weir	58
Figure 5.5	Calculated discharge Q_C plotted against weir head H for head-discharge relationship of contracted rectangular flat-crested slit weir	59
Figure 5.6	Theoretical discharge Q_T plotted against weir head H for head-discharge relationship of contracted rectangular flat-crested slit weir	59
Figure 5.7	Sensitivity, change in weir head for unit change in discharge dH/dQ as function of actual discharge Q_A for contracted rectangular flat-crested slit weir	65
Figure 5.8	Sensitivity, change in weir head for unit change in discharge dH/dQ as function of weir head H for contracted rectangular flat-crested slit weir	65
Figure 5.9	Actual discharge Q_A plotted against calculated discharge Q_C for contracted rectangular flat-crested slit weir	70
Figure 5.10	Actual discharge Q_A plotted against theoretical discharge Q_T for contracted rectangular flat-crested slit weir	70
Figure 5.11	Discharge coefficient C_d plotted against weir head H at $P = 0.035$ m and 0.075 m for contracted rectangular flat-crested slit weir	74

..continued

Figure 5.12	Discharge coefficient C_d plotted against weir head H at different weir height P for contracted rectangular flat-crested slit weir	75
Figure 5.13	Discharge coefficient C_d plotted against H/b at $P = 0.035$ m and 0.075 m for contracted rectangular flat-crested slit weir	76
Figure 5.14	Discharge coefficient C_d plotted against H/b at different weir height P for contracted rectangular flat-crested slit weir	77
Figure 5.15	Discharge coefficient C_d plotted against H/P at $P = 0.035$ m and 0.075 m for contracted rectangular flat-crested slit weir	78
Figure 5.16	Discharge coefficient C_d plotted against H/P at different weir height P for contracted rectangular flat-crested slit weir	79
Figure 5.17	Discharge coefficient C_d plotted against H/t at $P = 0.035$ m and 0.075 m for contracted rectangular flat-crested slit weir	80
Figure 5.18	Discharge coefficient C_d plotted against H/t at different weir height P for contracted rectangular flat-crested slit weir	81
Figure 5.19	Discharge coefficient C_d plotted against Reynolds number R at $P = 0.035$ m and 0.075 m for contracted rectangular flat-crested slit weir	83
Figure 5.20	Discharge coefficient C_d plotted against Reynolds number R at different weir height P for contracted rectangular flat-crested slit weir	84
Figure 5.21	Discharge coefficient C_d plotted against Weber number W at $P = 0.035$ m and 0.075 m for contracted rectangular flat-crested slit weir	85
Figure 5.22	Discharge coefficient C_d plotted against Weber number W at different weir height P for contracted rectangular flat-crested slit weir	86
Figure 5.23	Discharge coefficient $C_d(A)$ plotted against estimated discharge coefficient $C_d(E)$ for contracted rectangular flat-crested slit weir	90

LIST OF ABBREVIATIONS

ASTM	American Society for Testing and Materials.
BSI	British Standards Institute
IILRI	International Institute for Land Reclamation and Improvement
ISO	International Organization for Standardization
USBR	United States Department of the Interior Bureau of Reclamation

LIST OF SYMBOLS

A	Cross-sectional area
B	Channel width
b	Weir width
C_d	Discharge coefficient
C_e	Effective discharge coefficient
C_w	Weir coefficient
dA	Area of the strip
dh	Vertical height of the strip
dh/dQ	Weir sensitivity
$E\%$	Error in percentage unit
g	Gravitational acceleration = $9.81 \text{ m}^2/\text{s}$
H	Weir head
h	Depth of water from the strip
H_t or H_T	Total head
H_v	Velocity head
K	Flow coefficient
n	Exponent number
P	Pressure
P	Weir height
Q	Discharge
Q_E	Estimated discharge
Q_T or Q_{Te}	Theoretical discharge
Q_A	Actual discharge

Q_C	Calculated discharge
R	Reynolds number
R^2	Coefficient of determination
t	Weir crest thickness
V	Mean velocity
V_1	Approach velocity
W	Weber number
Z	Elevation head
α_1	ratio of Q_A/Q_P
α_2	ratio of Q_A/Q_T
ν	Kinematic viscosity
μ	Dynamic viscosity
σ	Surface tension
σ	Standard deviation
σ_m	Standard error of the mean
ρ	Density of water
γ	Specific weight
$\Delta Q\%$	Discharge deviations in percentage unit

**PENYELIDIKAN ALIRAN AIR DI ATAS EMPANG LIMPAH
BERSEGIEMPAT TEPAT TERKECUT LEKAH YANG MEMPUNYAI
PUNCAK RATA PADA SALURAN TERBUKA**

ABSTRAK

Empang limbah adalah struktur hidraulik yang tertua dan mudah pembinaannya telah digunakan ke atas saluran terbuka sejak dahulu oleh para jurutera untuk tujuan pengukuran aliran, lesapan tenaga, lencongan aliran, pengaturan kedalaman aliran, saluran banjir dan lain-lain lagi. Terdapat banyak persamaan kadar alir untuk empang limbah bersegiempat tepat puncak tajam pada paras tinggi empang limbah, turus empang limbah dan kadar alir air yang berbagai saiz tetapi sebaliknya bagi empang limbah bersegiempat tepat terkecut lekah puncak rata. Dalam kajian ini, konsep empang limbah lekah diperluaskan ke atas empang limbah bersegiempat tepat terkecut lekah puncak rata yang diuji untuk mengukur kadar alir yang rendah pada paras ketinggian empang limbah yang berlainan. Kajian dijalankan ke atas sembilan empang limbah lekah yang berlainan ketinggiannya dengan lebar 10 mm dan tebal puncaknya adalah 4 mm. Pekali kadar alir pada persamaan umum empang limbah yang diperolehi melalui ujikaji yang dijalankan pada kajian ini ialah 0.69. Hubungan di antara pekali kadar alir dengan parameter utama tak berdimensi juga telah diperolehi melalui kajian ini. Persamaan kadar alir yang dicadangkan di tesis ini boleh digunakan untuk mengira anggaran kadar alir air dengan tepat ke atas empang limbah bersegiempat tepat terkecut lekah puncak rata.

INVESTIGATION OF WATER FLOW OVER CONTRACTED RECTANGULAR FLAT-CRESTED SLIT WEIR IN OPEN CHANNEL

ABSTRACT

Weirs are among the oldest and simplest hydraulic structures that have been used for many years by hydraulic engineers for flow measurement, energy dissipation, flow diversion, regulation of flow depth, flood passage and other means in open channels. A number of discharge equations are available for rectangular sharp-crested weirs at various weir heights, weir heads and discharge flows of water but such equations are not available for contracted rectangular flat-crested slit weirs. In this study, the slit weir concept is extended for contracted rectangular flat surface of weir crest to measure the discharges of small flow rates at different weir heights. This study was carried out on nine different weir heights with 10 mm weir width and 4 mm weir crest thickness. The discharge coefficient in the general weir equation has been determined experimentally to be 0.69. The relationship between the discharge coefficient and the main dimensionless parameters is obtained. The recommended discharge equation obtained from this thesis can be used to accurately estimate water flow over contracted rectangular flat-crested slit weirs.

CHAPTER 1

INTRODUCTION

1.1 Background

Water resources play a very important role in national development and constitute a critical input for economic planning. The availability of water becomes increasingly important to mankind as the population expands and industry develops. Water district authority will need to seek ways to extend the use of water by the best available technologies rather than finding and developing new sources.

Knowledge of the quantity available water is the first stage in the efficient management of the water resources and the key is good water measurement practices thus, a basic understanding of flow in open channel is essential. The lack of good water measurement can cause drainage problems, excessive seepage losses, canal or dam breaks, poor on-farm irrigation, excessive erosion and poor water quality (Williams et al. 1993).

1.2 Flow in Open Channels

Open channel flow involves the flow of liquid (usually water) in a channel or conduit that is not completely filled in which a liquid flows with free surface subjected to a constant pressure (usually the atmosphere) and is driven by gravity (Munson et al. 2006). As a result, with steady uniform flow under free discharge conditions, a progressive fall or decrease in the water surface elevation always occurs as the flow moves downstream. Open channels can be classified as either natural or artificial (Sturm 2001). Natural open channels refer to all channels, which have been developed by natural processes and have not been significantly improved by humans

such as brooks, streams, rivers and estuaries. Artificial open channels refer to all channels which have been developed by human efforts to convey water for certain purposes such as water-power development, city water supply, storm sewers, sanitary sewers, irrigation canals, drainage ditches, aqueducts and flood diversion channels. Consequently, it is important that a channel can be designed to carry a particular discharge, or the discharge in a channel can be calculated from measurements of the bed slope, the width and the depth of flow.

The complexities offered by open channel flow due to the free surface rather than closed conduit can be dealt with through a combination of theory and experiments as in other branches of fluid mechanics. The basic principles of continuity, energy conservation and force-momentum flux balance must be satisfied, but often the investigation must resort to experiments to complete the solution of the problem.

1.3 Flow Measurements in Open Channels

Flow measurements are essential in many applications such as transportation of solids as slurries, compressed natural gas in pipelines, water and gas supply systems to domestic consumers, irrigation systems and a number of industrial process control system (Nakra and Chaudry 2004). As mentioned in Section 1.2, measurement of flow rates in open channels is difficult because of non-uniform channel dimensions and variations in velocities across the channel. The measuring of discharge at various points in the system is useful and necessary when the water available from a particular source is limited and must be used very carefully, where people have to pay for the water used and for settling any disputes of water

distribution. The main techniques for flow measurement in open channels (Ackers et al.1978); hydraulic structures; velocity-area methods; dilution techniques and slope-hydraulic radius-area methods.

Hydraulic structures are devices, which are used to regulate or measure flow in open channels and can be grouped into three categories (Chadwick et al. 2004):

- i. Flow measuring structures, eg. weirs and flumes
- ii. Regulation structures, eg. gates or valves
- iii. Discharge structures, eg. spillways or culverts.

A flow measurement structures in the first category are classified into those that measure pressure or head. Weirs are among the oldest simplest hydraulic structures which have been used for many years (Borghei et al. 1999). In case of weirs, the head is measured and then charts, tables or equations are used to obtain the discharge. In addition, the hydraulic design of a measurement structure has to consider the range of discharges to be accommodated, the requisite accuracy of measurement and the need for a structure geometry that fits economically into the work purposes. Figure 1.1 shows the example of weir for flow measurement in the field.

Discharge measurements must also be performed in the laboratory. The main difference between field and laboratory is the controlled environment of laboratory so that better measuring system can be used. The principles used for determination of discharge in the field are equally applicable to the laboratory.

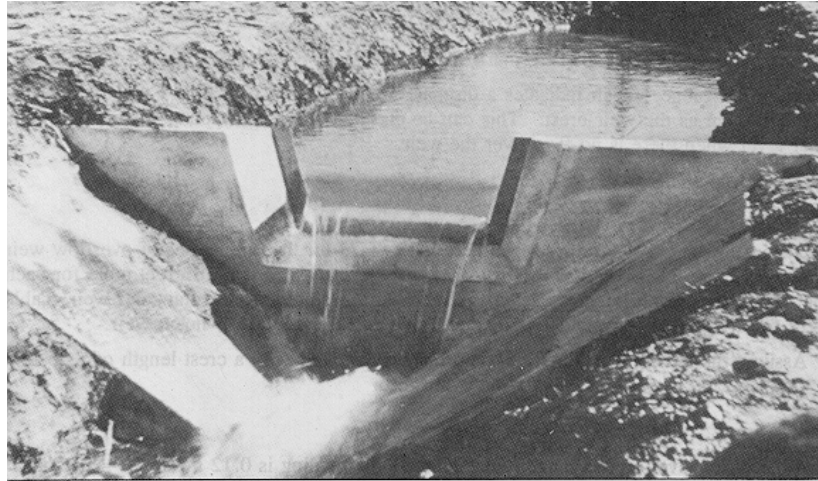

Figure 1.1: The trapezoidal weir, a sharp-crested weir for flow measurement.
(Source: Irrigation water management, training manual no.8, IILRI Italy, 1993)

1.3.1 Weirs

A weir is a structure built across a channel to raise the level of water, with the water flowing over it. In other words, any obstruction having an approximately uniform cross section, placed in a channel so that the water must flow over it, is a weir. Weirs are installed either as a means of controlling water levels in an upstream channel or as a means of accurately measuring the discharge (May et al. 2003). The edge or surface over which the water flows is called the crest. The overflowing sheet of water is termed the nappe. If the nappe discharges into the air, the weir has free discharge or free flow (Figure 1.2). If the discharge is partially under water, the weir is submerged or drowned (Figure 1.3). The channel of approach is the channel leading up to the weir, and the mean velocity in this channel is called the velocity of approach V_1 . The depth of water flowing above the crest is the head H . Those terms are shown in Figure 1.2. The several factors affecting the flow over weirs are the

head, fluid properties and temperature effects, approach and tail water conditions, weir geometry and measurement accuracies.

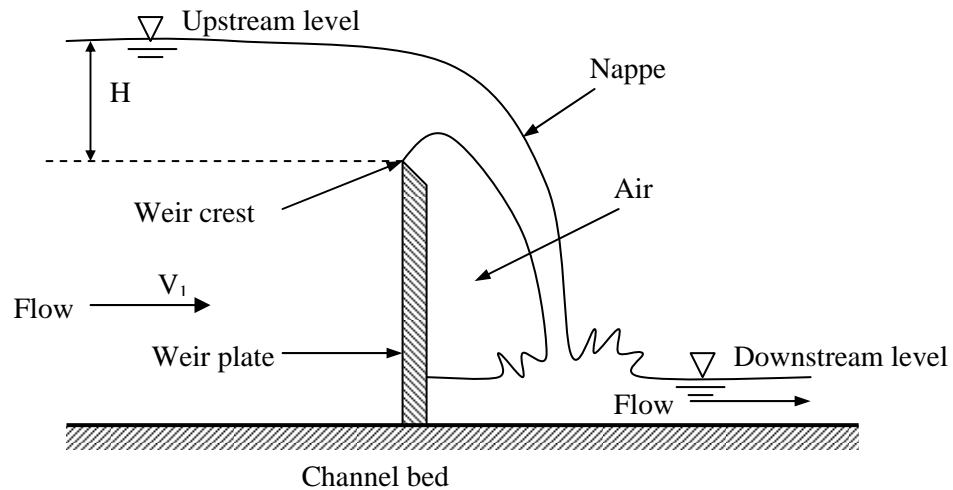

Figure 1.2: Free flow of water over a weir

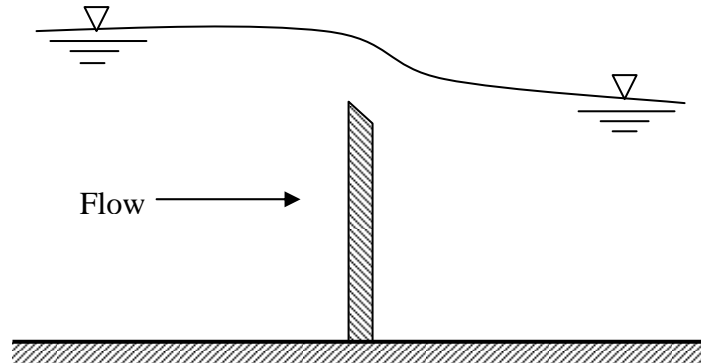

Figure 1.3: Submerged flow of water over a weir

The advantages and disadvantages of weirs are as follows (Merkley 2004):

i. Advantages

- Capable of accurately measuring a wide range of flows.
- Tends to provide more accurate discharge ratings than flumes and orifices.

- Easy to construct.
 - Can be both portable and adjustable.
 - Most floating debris tends to pass over the structure.
- ii. Disadvantages
- Relatively large head required, particularly for free flow conditions. This precludes the practical use of weirs for flow measurement in flat areas.
 - The upstream pool must be maintained clean of sediment and kept free of weeds and trash, otherwise the calibration will shift and the measurement accuracy will be compromised.

A weir with a crest where the water springs free (free flow) of the crest at the upstream side (except for very low heads, i.e. less than 60 mm (USBR 1997)) is called a sharp-crested weir (Figure 1.2 and 1.4a). If the water flowing over the weir does not spring free and the weir crest thickness (t) is either small or big, the weir is called a not sharp-crested weir (Figure 1.4b). The contracted weir (Figure 1.5) has a length (b) of weir smaller than the width of the approach channel (B). A weir having its length (b) equals to the width of the approach channel (B) is called a uncontracted weir (Figure 1.6). Weirs can be classified in two ways King and Wisler (1922):

- i. With reference to the opening of geometrical shapes such as rectangular, triangular and trapezoidal.
- ii. With reference to the cross-sectional form at the crest. Weir crests are constructed of many cross sectional forms, but they all come under one of the general headings, (a) sharp-crested weirs, which are used

primarily for the measurement of flowing water and (b) weirs not sharp-crested which are used primarily as a part of hydraulic structures.

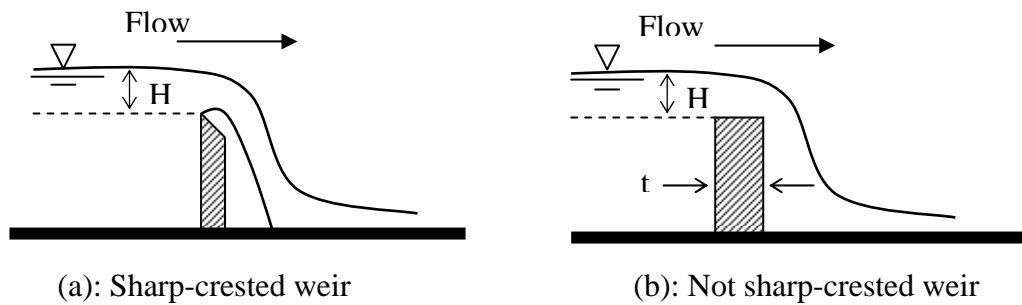

Figure 1.4: Flowing of water over sharp-crested and not sharp-crested weir

1.3.1.1 Sharp-Crested Weirs

A sharp-crested weir (or thin-plate weir) is a weir consists of a vertical plate fixed to the channel bed and is provided with a sharp top edge (Figure 1.2 and 1.4a). Although, theoretically the top edge is zero thickness, in actual practice the top of the plate is 1 to 2 mm long in the flow direction and the downstream edge is beveled at angle of 45° to 60° (Raju 1993). Upstream side must be smooth and at angle 90° of the top edge. Commonly used shapes of sharp-crested weirs are rectangular, trapezoidal (or cipolletti), and triangular (or V-notched). Figure 1.5 to 1.8 show a sketch of a sharp-crested of contracted and uncontracted rectangular weir, triangular weir and trapezoidal weir. The material to be used will depend on the corrosive qualities of the fluid to be gauged; brass, aluminum alloy, stainless steel, galvanized metal and plastic sheet are all possibilities to be considered.

In sharp-crested weir, the sharpness of the edge is required to be maintained properly otherwise with the change in the sharpness of the crest will affect the characteristics of the weir. Sharp-crested weirs are useful only as a means of measuring flowing water and generally used to measure the discharge in small open channel. Because the weirs have thin and sharp crests, they are not suitable for use in large rivers and with dirty fluids, which deposit in the approach channel behind the weir and destroy the conditions required for accurate discharge measurements. The performance of the device is sensitive to the accuracy with which the corner finished of sharp edge (Ackers et al.1978).

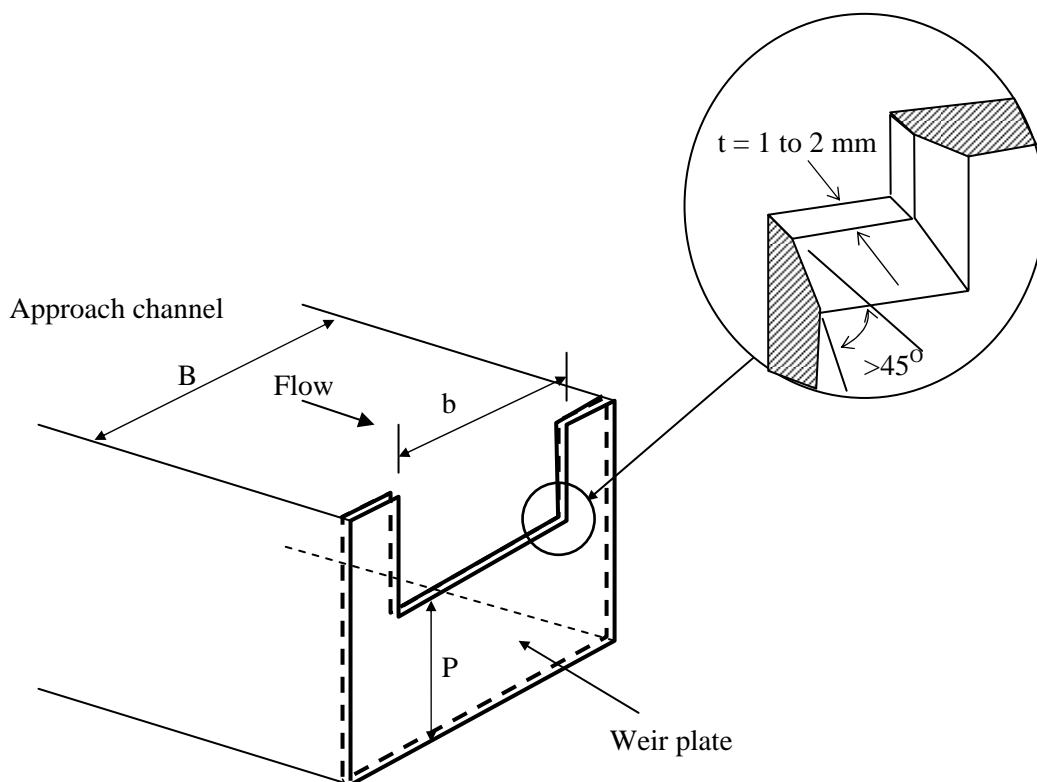

Figure 1.5: Sketch of contracted rectangular sharp-crested weir

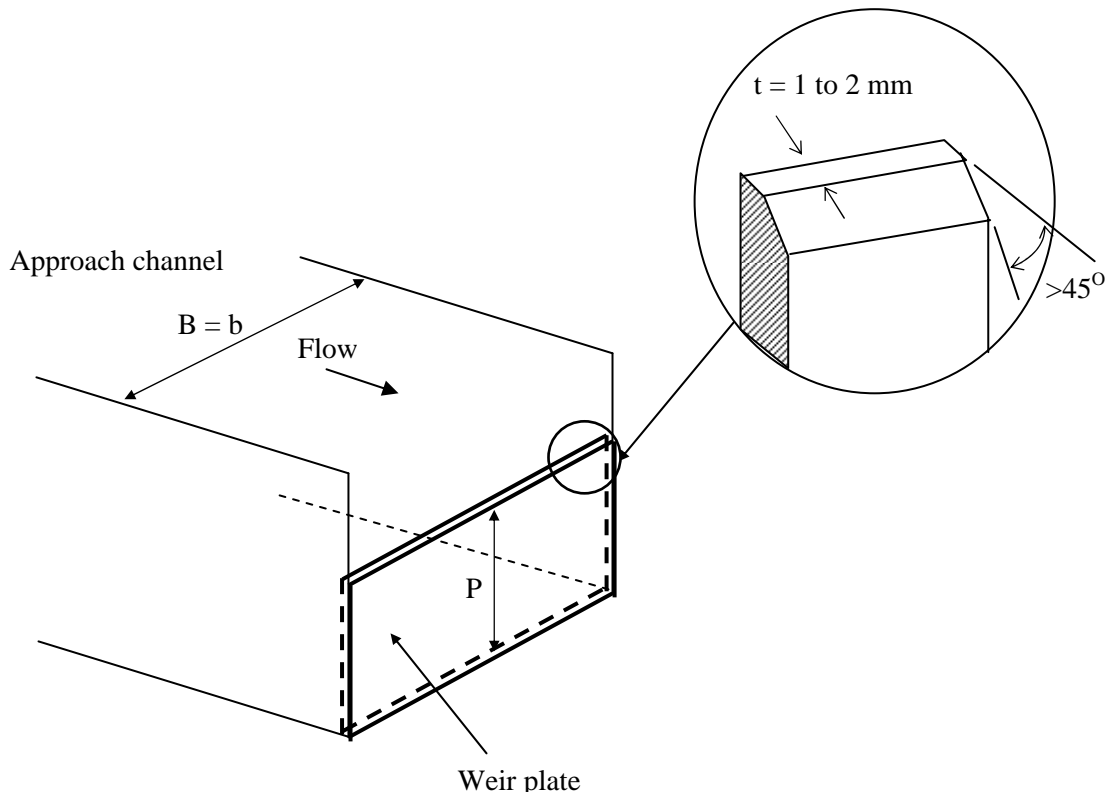

Figure 1.6: Sketch of uncontracted rectangular sharp-crested weir

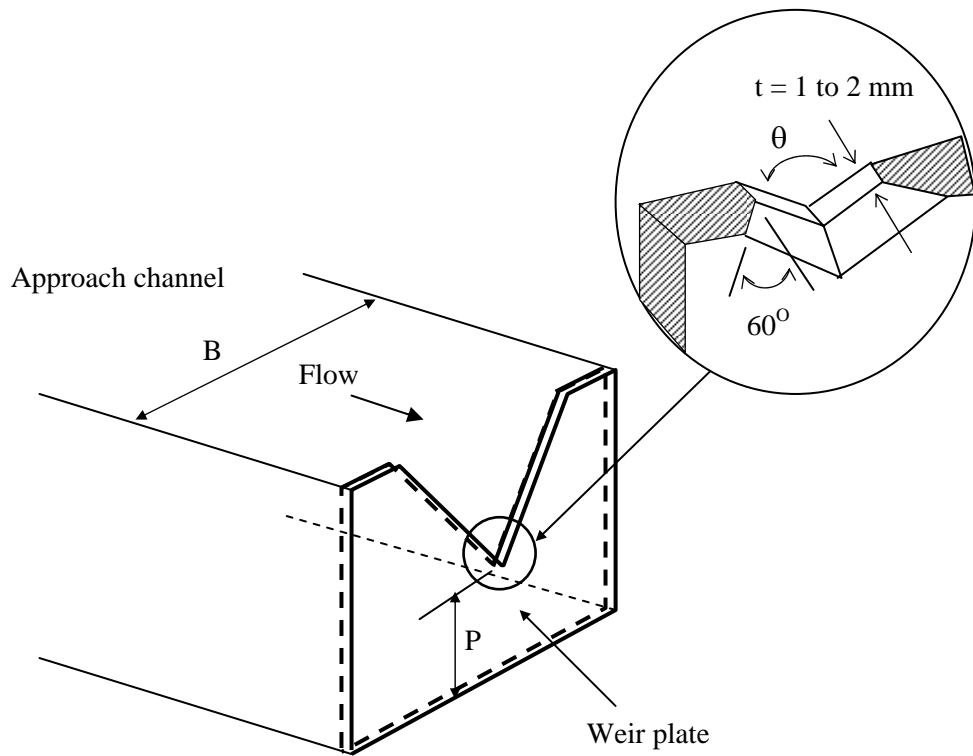

Figure 1.7: Sketch of triangular sharp-crested weir

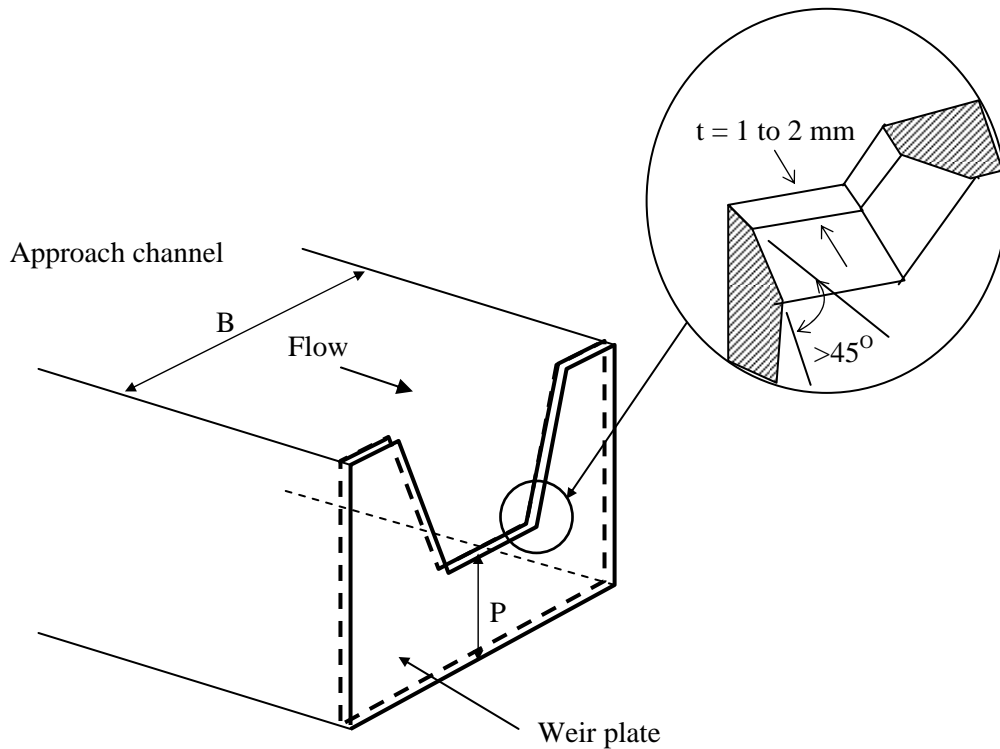

Figure 1.8: Sketch of trapezoidal sharp-crested weir

1.3.1.2. Weirs Not Sharp-Crested

If used to obtain discharge records for long periods, sharp-crested weirs are difficult to maintain due to crest become dulled or rusted or damaged by debris. Under such conditions it may be advisable to use a weir with a thicker crest in which must be more than 2 mm. Spillway sections of dams are examples of this type of weir. Weirs not sharp-crested (Figure 1.4b and 1.9) are commonly incorporated into hydraulic structures as control or regulation devices, with measurement of flow as their secondary. The weirs also termed as weirs with finite crest width. They are usually designed for use in the field, and consequently to handle large discharges. The amount of fluid that will pass over a weir not sharp-crested depends to a large extent on its sectional form and the shape of its crest. Weirs not sharp-crested are constructed in a wide variety of cross-sectional forms and have surface contraction

similar to sharp-crested weirs, but conditions at the crest are different and vary with the sectional form. Weirs not-sharp-crested are classified according to the shape of weir cross section (Ricketts et al. 2003) and such examples are shown in Figure 1.10 to 1.13. Among the weirs of not sharp-crested, the rectangular weir with horizontal crest is the most common.

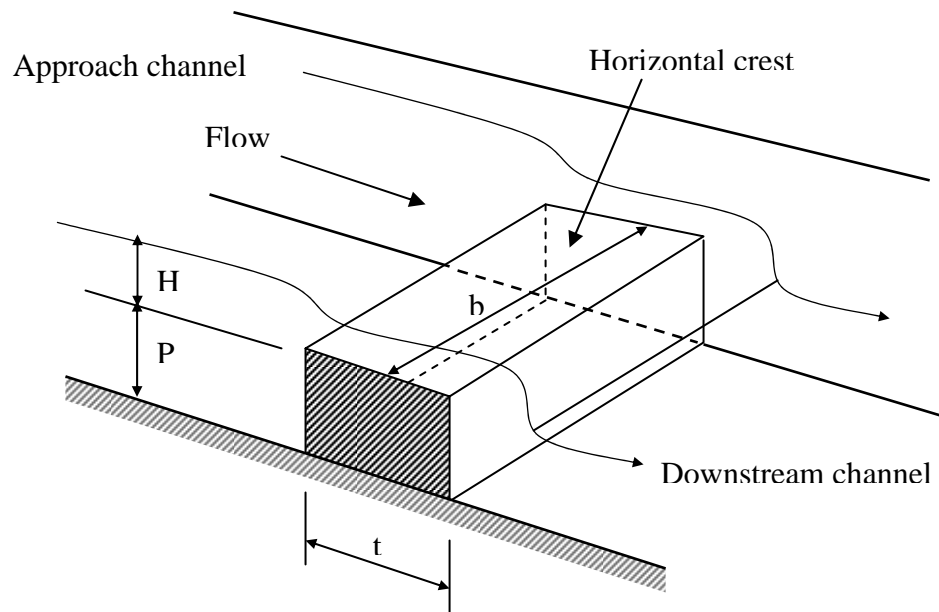

Figure 1.9: Flow over a weir not sharp-crested

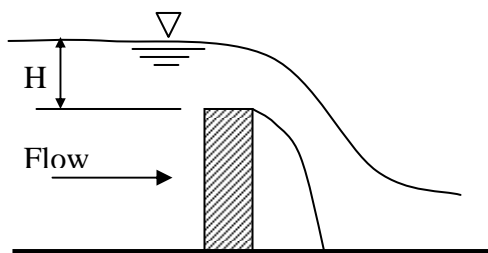

Figure 1.10: Flow over a weir with rectangular cross-section

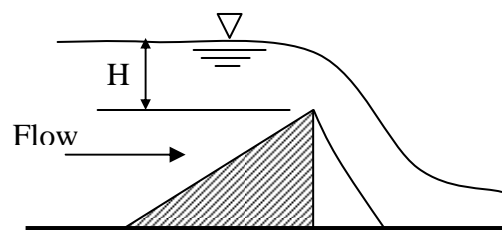

Figure 1.11: Flow over a weir with triangular cross-section

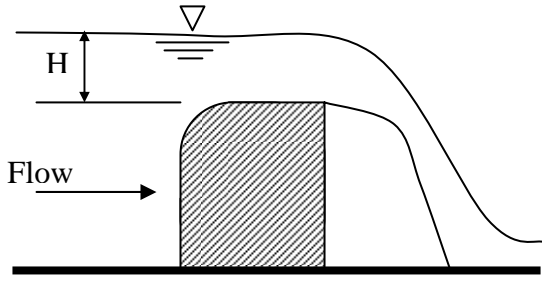

Figure 1.12: Flow over a weir with rounded entry cross-section

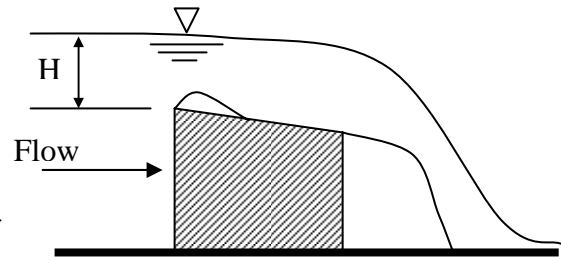

Figure 1.13: Flow over a weir with sloping crest cross-section

Based on the value of H/t (Figure 1.9), four types of finite-crest width weirs can be classified (Govinda Rao and Muralidhar 1963: source; Subramanya 2005) for the flow over a rectangular weir with an upstream sharp corner as follows:

- i. Long-crested weir ($H/t \leq 0.1$)
- ii. Broad-crested weir ($0.1 \leq H/t \leq 0.35$)
- iii. Narrow-crested weir ($0.35 \leq H/t \leq 1.5$)
- iv. Sharp-crested weir ($H/t \geq 1.5$)

In fourth classification, the flow separates at the upstream corner and jumps clear across the weir crest. Hence, the weir behaves as a sharp-crested weir. Based on this classification, the contracted rectangular flat-crested weir (Figure 1.14) as used in this study was fabricated. In this thesis, a weir geometry investigated is called contracted rectangular flat-crested slit weir. The weir, named a 'slit weir' is a narrow, i.e. weir width b is small, vertical and the geometry shape is rectangular. If the weir width is more than 0.075 m, it is not considered as a slit weir (Aydin et al. 2002). Thus, following their recommendation, the weir width b equals to 0.01 m is used for this investigation.

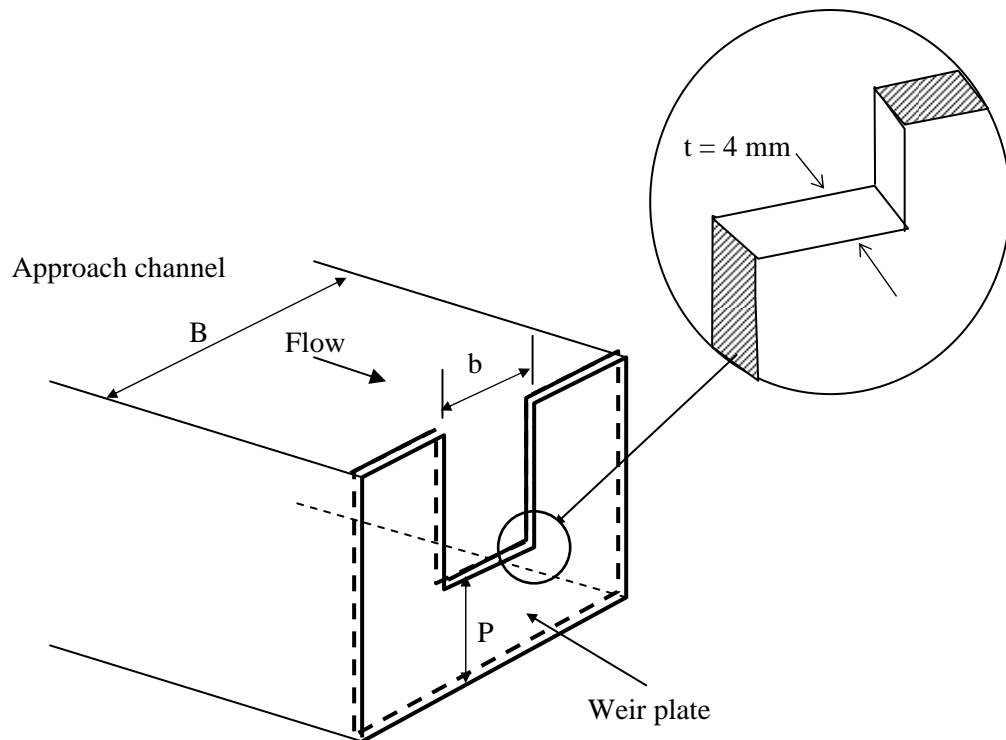

Figure 1.14: Sketch of contracted rectangular flat-crested slit weir

1.3.1.3 Selection of Weirs

Selection of the proper water measurement device is dependent on a variety of factors such as accuracy requirements, head loss, cost, legal constraints, range of flow rates, types of measurements and records needed, maintenance requirements, device standardization and calibration and etc. The ease of the discharge that can be measured or regulated is frequently more important since this will reduce the cost of operation (Bos 1989).

Selection of weir for a particular situation depends on the range of discharges to be measured, the accuracy desired and whether or not the weir can be calibrated after installation. Sharp-crested weirs have the advantage that laboratory calibration conditions can be quite accurately reproduced in the field (Brater et al. 1996). Each

weir has characteristics suited for particular operating conditions. Triangular weir is used for precise measurement at low discharges whereas the rectangular weir is used to measure at large discharges. Trapezoidal weir can be used for wide range of discharges. Triangular weir can measure more accurate flow than rectangular weir and trapezoidal weir's measurement is less accurate than triangular and rectangular weir's measurement. At low heads (< 60 mm), the nappe has a tendency to adhere to the downstream face of a rectangular weir, thus a triangular weir should be used.

1.3.2 Measurement Accuracy of the Flow

Accurate application of water measuring devices generally depends on standard design or careful selection of devices, care of fabrication and installation, good calibration data and analyses, and proper user operation with enough frequent inspection and maintenance procedures. All methods of flow measurement are subject to error, as it is for every measurement in science and engineering (Ackers et al. 1978). Even though in ideal conditions, repeated measurement of a reference standard will give slightly different instrument readings either; greater or less than this value.

Errors are minimized by careful application of the technique. It is greatly enhanced and useful for the flow rate measurement if a statement of possible error accompanies the result. The error may be defined as the difference between the true flow rate and the flow rate, which is calculated from the measured water level (upstream head) with the aid of the appropriate head discharge equations (Bos 1989).

Accuracy is the degree of conformance of a measurement to a standard or true value (USBR 1997). It is better to give a range, which is expected to cover the true value of the measured quantity with a high degree of probability, which is usually 95% that is adopted as the confidence level for all errors in this study. Most methods or measurement devices can produce accuracies within $\pm 5\%$ of actual discharge (USEPA 2001).

1.3.3 Discharge Coefficient

Real liquids are very difficult to describe mathematically when they are flowing because friction, viscosity and turbulence should be considered (Hamil 2001). The only practical approach to derive the discharge equation is by assuming that the real fluid behaves like an inviscid or ideal fluid (i.e. without considering them). This means that many of the equation need not to be accurate. However, this can be compensated by determining experimentally the value of the 'fiddle factor', so that the simple equations for an ideal liquid give accurate answers for a real liquid. This factor is called coefficient of discharge C_d , where:

$$C_d = \text{actual discharge } Q_A / \text{theoretical discharge } Q_{Te} \text{ or}$$
$$C_d = Q_A/Q_{Te} \tag{1.1}$$

Much time and effort has been devoted by the investigators and researchers for obtaining accurate C_d values for the several flow measuring devices. The accuracy of the discharge measurement depends on the accuracy of the coefficient of discharge, as well as on how well the theoretical equation describes the flow. The accuracy of the values substituted into the equation such as head and cross sectional area of flow is also very important measurement factors.

1.4 Problem Statement

The basics of open channel flow measurement are well known but it depends on numerous studies to evaluate the empirical discharge equations and coefficients. This can be achieved by obtaining fresh data, particularly in modern practice to add to the existing evidence. Weirs have been extensively studied and applied as flow measurement devices and as well as water control structures in a wide range of agricultural, chemical engineering and municipal applications. Most of the researchers have studied experimentally related to the surface profile, pressure distribution, velocity distribution, air entrainment, fluid properties effects and discharge coefficient as well as discharge equations.

A number of discharge equations are available for rectangular sharp-crested weirs at various weir heights, weir heads and discharge flows but such equations are not generally available for contracted rectangular flat-crested slit weirs. Consequently, the engineers or operators of waterworks cannot be able to predict the discharge as well as discharge coefficient due to no discharge equations of water flow over contracted rectangular flat-crested slit weir. Hopefully, the contracted rectangular flat-crested slit weir will be important as an alternative of weir selection with appropriate applications.

1.5 Objectives

The objectives of this research are listed below:

- i. To obtain the discharge coefficient of water flow over contracted rectangular flat-crested slit weir.

- ii. To find the relationships between discharge coefficient and several important dimensionless parameters in flow measurement of water over contracted rectangular flat-crested slit weir.
- iii. To develop a discharge equation of water flow over contracted rectangular flat-crested slit weir, which can be used to predict the discharges flow over it.

1.6 Outline of Dissertation

This thesis consists of six (6) chapters. The first chapter gives the necessary background on flow in open channel, flow measurement in open channel, discharge coefficient and selection of water measuring devices. Besides that, the problem definition and the thesis objectives are also presented. The second chapter describes the overview of the previous works in the field of interest and gives necessary information to proceed throughout the thesis. The general theory of flow over weir and the related equations are presented in chapter three (3). In this chapter, general principles of fluid flow, measurement of discharge and related information on dimensionless parameters that describe the function of discharge coefficient are also presented. Chapter four (4) describes the experimental setup and procedure used for experimental works. Chapter five (5) presents the result for data analysis and discussion. The analysis obtained in this chapter is then developed to obtain the related discharges equation. Finally chapter six (6) highlights the conclusion drawn from the work in this thesis.

CHAPTER 2

LITERATURE REVIEW

2.1 Introduction

In this chapter, a literature review of the four (4) main topics is presented.

The topics covered are as follows:

- i. Flow measurement structure
- ii. Rectangular sharp-crested weir
- iii. Weirs not sharp-crested
- iv. Remarks on existing study of weir

2.2 Flow Measurement Structure

Flow measurement structure is generally designed to act as a control in the channel in order to provide a unique relationship between the upstream head and the discharge (Boiten 2002). Several standard sources such as the International Organization for Standardization (ISO), British Standards Institute (BSI), American Society for Testing and Materials (ASTM), and other standard organizations provide the outlines for the design requirements, discharge relationship, and the set-up of rating curves for most of the commonly used flow measurement structures. For non-standard structures, handbooks such as Ackers et al. (1978), Bos (1989), USBR (1997) and Clemmens et al. (2001), and the literature such as Herschy (1995), Chatterjee et al. (2002), Aydin et al. (2002 and 2006), Martinez et al. (2005), and Igathinathane et al. (2007) can be consulted.

2.3 Rectangular Sharp-Crested Weirs

Weirs have been used for a number of decades for the measurement of discharge in channel and also have been studied through experimental tests and theoretical prediction by many investigators. Regarding the flow of water over sharp-crested weir, many studies have been reported in the literature such as Ramamurthy et al. (1987), Singh et al. (1994), Wu and Rajaratnam (1996), Swamee et al. (1998), Prakash and Shivapur (2004) and Baddour (2008). A large number of formulas for sharp-crested have been published but only those best known or those appearing to possess the greatest merit will be given in this thesis. The first systematic investigation of the overall flow behaviour is due to Poleni in the 18th century (Miller et al. 1994).

In all the earlier experiments on weirs, small quantities of water were used. The Francis experiments were performed in 1852 by using larger quantities of water for uncontracted and contracted rectangular sharp-crested weir and the coefficient of discharge equation as well as for discharge formula were developed. Brater et al. (1996) have explained in `Handbook of Hydraulics`, many researchers such as Fteley and Stearns (1877 and 1879), Bazin (1886), Swiss Society of Engineers and Architects (1924), Rehbock (1929) and Kindsvater and Carter (1957) performed the experiment of rectangular sharp-crested weir. These investigators produced coefficient of discharge whose value must be discovered by experiment and relevant empirical relationships relating discharge equations were obtained. The experiments were conducted at different sizes of weir heights, weir widths, flow rates, heads, and fluid properties consideration.

Most discharge relations for weirs predict the discharge reasonably well at moderate and high heads but not well at low heads. The effects of viscosity and surface tension of the liquid are important at low heads and have not been properly considered in deriving the discharge relations. These effects were considered in Kinsdvater and Carter (1957: source; Brater et al. 1996) where the formula for rectangular sharp-crested weir flow of water was derived by adding a correction factor to the head. Raju (1977) introduced a correction factor to account for effects of viscosity and surface tension at low heads for flow of mixture of kerosene oil and mobil oil. The experiments were conducted on uncontracted rectangular sharp-crested weirs and 90^0 triangular sharp-crested weirs.

Discharge relationships for low head of water flows over uncontracted rectangular sharp-crested and a 90^0 triangular sharp-crested weir are not readily available in books or standards. So, practicing engineers have to calibrate their set-up again and again. In addition, the interpolation of data is a tedious job too. This necessitates finding reasonably accurate relationships for discharge measurement that was investigated by Mitra and Mazumdar (2004). The coefficient of discharge was determined experimentally and the effects of various parameters like viscosity, surface tension, and velocity of approach on the variation of coefficient of discharge was examined separately.

Since weirs have been used as flow measuring devices, the effect of the relative crest height on discharge coefficient must be cleared. Calculation of the actual discharge over weir is complicated due to the curvature of the streamlines in both vertical and horizontal directions of the flow. Experimental study was carried

out by El-Alfy (2005) to investigate the effect of vertical curvature of flow streamlines due to change in weir crest height and the effect of head angle on discharge coefficient. The study was carried out on sharp-crested weirs of contracted rectangular, triangular weir, and trapezoidal weir and also broad-crested weir under different flow conditions.

Aydin et al. (2002) introduced the concept of slit weir. This weir is a contracted rectangular sharp-crested with very small weir width, in which is effective in measuring very small of water flow rates. The coefficient of discharge is determined experimentally and the relationship with the main dimensionless parameters is obtained. Various sizes of weir height, and slit width are used in the experiment. Aydin et al. (2006) extended the experiment of contracted rectangular sharp-crested slit weir to study the effect of the slit width where more sizes of slit width are conducted in the study. Ramamurthy et al. (2007) extended the study of slit weir concept with experiments on contracted rectangular sharp-crested multislit weir (3, 7 and 15 unit of weirs). This concept is used to predict the water flow characteristics of a multislit weir capable of measuring a wide range (low and high) of flow rates. Discharge coefficient is determined experimentally and the relationship between discharge coefficient and the main dimensionless parameters is investigated.

2.4 Weirs Not Sharp-Crested

As the number of shapes of weirs not sharp-crested is unlimited, it is not to be expected that experimental data are available for all of them. The results of several series of experiments on weirs of different cross sections are still being investigated by researchers all around the world.

The broad-crested weir is recommended as a flow measurement structure, provided it satisfies some standard conditions. Hager and Schwalt (1994) analyzed experimentally the flow features (i.e. surface profile, separation profile, bottom pressure profile, and velocity profile close to the upper crest corner) over the broad-crested weir with vertical upstream wall and sharp-crested corner under the free flow and submerged flow. Gonzales and Chanson (2007) conducted basic experiments in a near full-scale broad-crested weir with rounded nose to measure systematically the velocity and pressure distributions on the weir, and discharge coefficient is also derived. These studies were rarely investigated in a large-size facility under controlled flow condition.

Much consideration has been given to weirs at various geometries and usually is classified based only on their physical geometry. The amount of head associated with the flow passing over the weirs is now being considered as another factor of weir classification (Johnson 2000). This finding comes from the investigation on flow of water over a rectangular flat-topped weir and sharp-crested weir at wide range of flow rates, various weir crest thickness, and weir height by considering the velocity head. As a result, the practicing engineers will not be confused with the data provided whether they are for flat-topped or sharp-crested weirs.

As the weir coefficient directly influences the discharge capacity of weir, it is worthwhile to increase the capacity without changing the hydraulic design of weirs. Based on the experimental investigations carried out by Mallikarjuna et al. (2006), a significant improvement in the weir coefficient is observed by suitably modifying the

crest shapes of weirs. The experiment is conducted on various crest shapes (not sharp-crested weirs) under free and submerged flow conditions.

2.5 Remarks on Existing Study of Weir

In all fields of engineering, there is a delay between the carrying out of research and the incorporation of its results into practical design and construction. Engineers designing or using flow measurement structures require knowledge of the accuracy of the derived discharges in order to satisfy themselves that the results are adequate for the purpose in hand. Hence, it is important to know the necessary guidance or information as mentioned in Section 2.2 when designing flow measurement structures or studying flow of water over weirs.

The rectangular sharp-crested is fundamental importance in the laboratory and in the field because it serves as a simple and accurate device for flow measurement and control in open channels. As it can be seen from the published literature (Section 2.3), although a quantity of work has been done by investigators on rectangular sharp-crested for normal weir width in obtaining a discharge coefficient as well as discharge equation in terms of the fluid properties and geometric properties of weirs, not enough work has been done on rectangular flat-crested slit weir.

There are some cross-sectional forms of weirs not sharp-crested which might be more satisfactory for the measurement of flowing water than sharp-crested weirs if a complete experimental data for them are available such as mentioned in Section

2.4. Complete data for any particular shape of weir requires an exhaustive research similar to that required for sharp-crested weirs.

Engineering experimentation, which in a general sense involves using the measurement process to seek new or further information, ranges in scope from experiments to establish new correct data and method of analysis, to conceive and verify theoretical concepts, and evaluate the performance and behaviour of existing weir. Consequently, the guidelines from the published documents such as International Organization for Standardization (ISO), British Standards Institute (BSI), water manuals and also the previous researchers as describe earlier in this chapter are needed to succeed in investigating the existing weir (contracted rectangular flat-crested slit weir).

The basic open channel flow measurements are well known but the dependence on numerous studies to evaluate the empirical equations and coefficients has meant considerable published data on these values. Hence, there will be a need to obtain fresh data. The study of the contracted rectangular flat-crested slit weir attempts to quantify the data of flow measurement capability. The concept of slit weir is continued in this thesis by using a flat-crested weir instead of a sharp-crested weir which was studied out experimentally by Aydin et al. (2002) and Ramamurthy et al. (2007). In addition, a contracted rectangular flat-crested slit weir has been selected in this thesis due to simplicity, easy maintenance and good flow measurement which is similar to the flow of rectangular sharp-crested weirs.