

**HUMAN HEAT ENERGY HARVESTING USING  
THERMOELECTRIC COOLER**

**By**

**WONG HUI PING**

**A Dissertation submitted for partial fulfillment of the  
requirements for the degree of Master of Science**

**June 2014**

## **Acknowledgment**

I would like to express my greatest and sincere appreciation to family member, my project supervisor, Dr. Zuraini Dahari for her constructive advices, encouragement and support throughout the period of this dissertation. She has been generously shares her valuable knowledge and ideas within the area of this project implementation. Next, I would like to thanks to USM and USAINS for the library facilities and also all the team support within the period of this project. Finally, special thanks to Ministry of Education Malaysia, MyBrain15 scholarship programme for sponsoring MyMaster Postgraduate study.

## Table of Contents

Acknowledgment.....	ii
Table of Contents.....	iii
List of Figures.....	vi
List of Tables .....	x
List of Abbreviations .....	xii
ABSTRAK .....	xiii
ABSTRACT .....	xiv
CHAPTER 1 .....	1
INTRODUCTION.....	1
1.1    Background.....	1
1.2    Problem Statement.....	2
1.3    Objectives .....	2
1.4    Project Scopes .....	3
1.5    Research Contribution .....	3
1.6    Thesis Organization.....	4
CHAPTER 2.....	5
LITERATURE REVIEW .....	5
2.1    Introduction .....	5

2.2	Human Heat Generation and Distribution in Environment.....	5
2.3	Human Heat within Bodies .....	8
2.4	Principles of Human Heat Generation to Electricity .....	10
2.4.1	The Seebeck Effect.....	10
2.4.2	The Peltier Effect.....	11
2.5	Energy Harvesting Applications.....	13
2.6	Human Heat Energy Harvesting Applications.....	15
2.7	Summary.....	22
CHAPTER 3.....		24
DESIGN METHODOLOGY AND IMPLEMENTATION .....		24
3.1	Introduction .....	24
3.2	Human Heat as Input .....	25
3.3	Thermoelectric Module : Peltier.....	26
3.4	Voltage Booster .....	27
3.5	LED output indicator .....	29
3.6	Experimental Testing by using Arduino UNO .....	30
3.7	Simulation by using LTSpice .....	32
CHAPTER 4.....		33
RESULTS AND DISCUSSIONS .....		33
4.1	Introduction .....	33
4.2	Circuit Design Schematic.....	33

4.3	Test Analysis.....	35
4.3.1	Experimental Results.....	35
4.3.2	Simulation Results.....	51
4.4	Discussions.....	59
4.5	Summary.....	62
CHAPTER 5.....		63
CONCLUSION AND RECOMMENDATIONS.....		63
5.1	Conclusion.....	63
5.2	Recommendations and Improvement.....	64
REFERENCES.....		65
APPENDIX A : Thermoelectric Cooler Datasheet.....		67

## List of Figures

Figure 2.1: Human heat impact to radiation (Santee and Gondalez, 1998) .....	7
Figure 2.2: Human heat generation within bodies (Despopoulos and Silbernagl, 2003)..	9
Figure 2.3: Thermoelectric module: Seebeck effect operation.....	11
Figure 2.4: Thermoelectric module: Peltier effect operation.....	12
Figure 2.5: Summary of natural resources energy harvesting from the human body (Chen, 2011).....	14
Figure 2.6: Body-powered wireless pulse oximeter (Leonov and Vullers, 2009).....	16
Figure 2.7: Body powered EEG headband; TEG (Yazicioglu et. al., 2007).....	16
Figure 2.8: Body-powered ECG headband; TEG and PV cells (Yazicioglu et. al., 2008).....	17
Figure 2.9: Neural recording system through Thermoelectric Power (Hmida et.al, 2009).....	18
Figure 2.10: CMOS MEMS based thermoelectric device (Jin et.al, 2010).....	18
Figure 2.11: A flexible TEG composed of polydimethylsiloxane (PDMS) substrate and thermocouples (Sung et. al., 2011).....	19
Figure 2.12: (a) Flexible TEG attached to body, (b) Exploded view of the TEG (Sung et. al., 2011).....	20
Figure 2.13: Carbon Nanotube Materials (Hewitt, et al, 2012).....	21

Figure 2.14: Human heat energy harvesting through hand rubbing and display on electronically in paper (Karagozler et, al, 2013).....	21
Figure 2.15: Flexible wrist band TEG (Yoon, 2014).....	22
Figure 3.1: Prototype Design Block Diagram.....	25
Figure 3.2: Liquid Crystal Thermometer.....	26
Figure 3.3: Peltier module, TEC-12706.....	26
Figure 3.4: (a) LTC3108 and (b) Pin configuration for LTC3108.....	28
Figure 3.5: (a) step-up transformer, (b) symbol and (c) pin configuration.....	28
Figure 3.6: Arduino UNO microcontroller board.....	30
Figure 3.7: Data logging for voltage output from Peltier module.....	31
Figure 3.8: Simulation for voltage output from Peltier module.....	32
Figure 4.1: Prototype design in prototype board.....	34
Figure 4.2: Prototype design in circuit diagram.....	34
Figure 4.3: Experimental result for human palm temperature.....	36
Figure 4.4: Experimental results for human palm using data logger.....	37
Figure 4.5: (a) Prototype circuit from human palm, (b) Experimental results for $V_{LED}$ ....	38
Figure 4.6: Experimental result for human top palm temperature.....	39
Figure 4.7: Experimental results for human top palm using data logger.....	40
Figure 4.8: (a) Prototype circuit from human top palm, (b) Experimental results for $V_{LED}$ .....	41
Figure 4.9: Experimental result for human wrist temperature.....	42

Figure 4.10: Experimental results for human wrist using data logger.....	43
Figure 4.11: (a) Prototype circuit from human wrist, (b) Experimental results for $V_{LED}$ ..	44
Figure 4.12: Experimental result for human top wrist temperature.....	45
Figure 4.13: Experimental results for human top wrist using data logger.....	46
Figure 4.14: (a) Prototype circuit from human top wrist, (b) Experimental results for $V_{LED}$ .....	47
Figure 4.15: Experimental result for human leg temperature.....	48
Figure 4.16: Experimental results for human leg using data logger.....	49
Figure 4.17: (a) Prototype circuit from human leg, (b) Experimental results for $V_{LED}$ ....	50
Figure 4.18: Simulation result for voltage input from Peltier shows 100 mV.....	51
Figure 4.19: Simulation result for voltage booster output shows 3.133 V.....	52
Figure 4.20: Simulation result for $V_{LED}$ is at 2.277 V.....	52
Figure 4.21: Simulation result for voltage input from Peltier shows 80 mV.....	53
Figure 4.22: Simulation result for voltage booster output shows 2.989 V.....	53
Figure 4.23: Simulation result for $V_{LED}$ is at 2.21V.....	54
Figure 4.24: Simulation result for voltage input from Peltier shows 70 mV.....	54
Figure 4.25: Simulation result for voltage booster output shows 2.893 V.....	55
Figure 4.26: Simulation result for $V_{LED}$ is at 2.174 V.....	55
Figure 4.27: Simulation result for voltage input from Peltier shows 60 mV.....	56
Figure 4.28: Simulation result for voltage booster output shows 2.8 V.....	56



Figure 4.29: Simulation result for $V_{LED}$ is at 2.108 V.....	57
Figure 4.30: Simulation result for voltage input from Peltier shows 20 mV.....	57
Figure 4.31: Simulation result for voltage booster output shows 2.483 V.....	58
Figure 4.32: Simulation result for $V_{LED}$ is at 1.898 V.....	58
Figure 4.33: Comparison between the simulation and experimental results for the output voltage from booster circuit.....	60
Figure 4.34: Comparison between Simulation and Experimental results for $V_{LED}$ .....	61
Figure 4.35: Power towards temperature.....	62

## List of Tables

Table 2.1: Summary on the on-going research on human heat detection and its application.....	23
Table 3.1: List of item used for voltage booster circuit prototype.....	29
Table 3.2: List of item used for LED output indicator circuit prototype.....	30
Table 4.1: Experimental results for human palm logged from Arduino UNO data logger.....	37
Table 4.2: Experimental results for $V_{LED}$ using human palm logged from Arduino UNO.....	38
Table 4.3: Experimental results for human top palm logged from Arduino UNO.....	40
Table 4.4: Experimental results for $V_{LED}$ using human top palm logged from Arduino UNO.....	41
Table 4.5: Experimental results for human wrist logged from Arduino UNO.....	43
Table 4.6: Experimental results for $V_{LED}$ using human wrist logged from Arduino UNO.....	44
Table 4.7: Experimental results for human top wrist logged from Arduino UNO.....	46
Table 4.8: Experimental results for $V_{LED}$ using human top wrist logged from Arduino UNO.....	47

Table 4.9: Experimental results for human leg logged from Arduino UNO.....	49
Table 4.10: Experimental results for $V_{LED}$ using human leg logged from Arduino UNO.....	50
Table 4.11: Summary of results.....	60
Table 4.12: Summaries for $P_{LED}$ .....	61

## **List of Abbreviations**

Abbreviation	Meaning
PDMS	Polydimethylsiloxane
TEG	Thermoelectric Generator
CNT	Carbon Nanotube
TEC	Thermoelectric Cooler

# **PENUAIAN TENAGA HABA MANUSIA DENGAN MENGGUNAKAN PENYEJUK TERMOELEKTRIK**

## **ABSTRAK**

Penyelidikan dalam penuaian tenaga diperbaharui semakin meningkat adalah kerana batasan sumber tenaga yang sedia ada. Sumber penuaian tenaga boleh diperbaharui yang terkemuka adalah seperti hidroelektrik, angin dan solar. Kajian ini memberi tumpuan kepada penuaian tenaga haba yang akan menukar haba buangan manusia kepada tenaga elektrik. Ia memberi fokus terhadap penukaran haba buangan daripada lima bahagian badan manusia iaitu tapak tangan, bahagian atas tapak tangan, pergelangan tangan, bahagian atas pergelangan tangan dan kaki kepada tenaga elektrik. Penyejuk termoelektrik digunakan untuk menukarkan haba daripada tubuh manusia kepada tenaga elektrik. Dalam kajian ini sebuah litar dibangunkan untuk meningkatkan voltan yang kecil kepada voltan yang lebih tinggi dengan menyalakan LED sebagai output. Berdasarkan keputusan eksperimen, voltan keluaran dari modul Peltier tertinggi diperolehi daripada bahagian atas tapak tangan manusia iaitu sebanyak 0.1 V. Voltan itu dapat ditingkatkan sehingga 2.9 V pada keluaran penggalak voltan. Voltan keluaran pada beban adalah 2.47V dan kuasa keluaran pada beban adalah 24.7 mW. Prototaip yang dibina mampu menjana haba buangan manusia kepada tenaga elektrik. Tapak tangan manusia adalah lokasi yang paling sesuai untuk menyalakan LED.

# **HUMAN HEAT ENERGY HARVESTING USING THERMOELECTRIC COOLER**

## **ABSTRACT**

An extensive research in renewable energy harvesting is increasing due to the limitation of energy resources. The known leading renewable energy harvesting sources is such as hydroelectricity, wind and solar. This research will focus on the human heat energy harvesting which will convert human waste heat to electricity. It focuses on converting the waste heat to electricity from five area of human body such as human palm, top palm, wrist, top wrist and leg. Thermoelectric cooler is used to convert the human body heat to electricity. In this research, a booster circuit is developed to boost the small voltage to higher voltage in order to power up an LED as output indicator. Based on experimental results, the maximum output voltage from Peltier module is obtained from human palm which is 0.1 V. The voltage is able to be boosted up to 2.9 V at the voltage booster output. The output voltage generated at load is 2.47 V and the power output is 24.7 mW. The prototype board built is able to generate human heat as electricity. Human palm is the most suitable location to power-up the LED.

# CHAPTER 1

## INTRODUCTION

### 1.1 Background

In recent years, an increasing concern of environmental issues of emissions, in particular global warming and the limitations of energy resources has resulted in extensive research into novel technologies of generating electrical power. The common energy resources are such as the sunlight (solar), wind, thermal (heat), and hydroelectricity. The known leading renewable energy harvesting generation sources are hydroelectricity, wind and solar.

This research will focus on energy harvesting from human heat, which is to convert the waste heat to energy. As the technology is emerging, human heat is able to generate electricity. This energy is clean and renewable, yet it has been remain unexploited despite its abundance from our body. The waste heat is also found to be beneficial in terms of its cleanliness and it is safe to human and the environment. Thus, this research is an effort to investigate the alternative source from a human body waste heat and turn it to useable electricity as it has the characteristic to provide a high and low power application. The example of the application is to power up multiple devices, from an ultra-small device to domestic appliances.

## **1.2 Problem Statement**

Most of researches on energy harvesting area focus on energy by water, wind, fossil fuel and solar which possess the criteria of low portability and may cause harm to animals and environment. Water energy conversion which is also known as hydroelectricity requires a dam for electricity generation, wind energy requires a wind turbine and it causes a lot of bats and birds death. Fossil fuel is one of the first energy generations but this energy has been protested as it harms human health. Solar energy is limited and available in few hours with different intensities with the possibilities of overcast days. There are multiple of explorations into renewable sources but the approach to a portable, economical energy harvesting percentage is small. In the current era, human uses multiple types of portable devices and of course these devices require batteries. Up to a certain time, the batteries needed to be charged within a certain hour and within a certain location which with the source from a power source.

## **1.3 Objectives**

Of all the current faced problems and limitation, a study on the human heat to generate electricity has been conducted. Below are the objectives of the thesis.

- i. To investigate on human heat energy generation from five area of human body parts which are human palm, human top palm, human wrist, human top wrist and also human leg.



- ii. To design and develop a prototype circuit for human heat energy generation to power up an LED.
- iii. To analyze the power output from the proposed prototype based on the five area of human body heat generation.

#### **1.4 Project Scopes**

The scope of this research will focus on the energy generated from human bodies. Small voltage generated from the body will be used to turn on an LED. This thesis will limit to lab scale simulation. In this work, a circuit with Peltier module as the input, a step up voltage circuit as a voltage booster and an LED as an output are used to investigate the possibility of human heat as a energy source.

#### **1.5 Research Contribution**

Human bodies able to provide an amount of waste heat as green energy. The production of human body heat can be utilized in some of the commercial devices such as emergency flash light. In this research, different human body heat temperatures are used to generate to electricity, and the final output is for commercial usage such as LED indicator. This method of human waste heat conversion provides environmentally friendly and reliable types of energy. This resource is unlimited and can be used anytime without external power supply.

## **1.6 Thesis Organization**

This thesis contains below chapters which will explain further details in order to achieve the results of the research.

Chapter 2 covers the fundamental knowledge and theoretical principles of the human heat generation, distribution and its conversion to electricity. This chapter also includes the on-going research on human heat detection and its application.

In Chapter 3 research methodology and implementation on the analysis of the methods applied to a field of study, or the analysis of the palm, wrist and leg methods and principles associated with a branch of knowledge. Typically, it includes concepts such as theoretical model.

Chapter 4 will explain on the result outcomes and the data analysis also the discussion of the project outcome. Finally, Chapter 5 describes the conclusion and future recommendations.

## **CHAPTER 2**

### **LITERATURE REVIEW**

#### **2.1 Introduction**

This chapter covers the background knowledge on human heat generation, distribution and the theoretical principles of heat to electricity generation. Multiple applications from the previous works for numerous types of energy harvesting will also be described in this chapter.

#### **2.2 Human Heat Generation and Distribution in Environment**

Human heat is a kind of energy that is gained by two methods which is from human metabolic and environmental variables (Fangers, 1970). A study shows that the sun temperature is around 5500 °C. This generates the thermal environment and it will determine a human's thermal level. Human response to the thermal environment when the presence of four basic environment variables. The four basic environment variables are stated as air temperature, mean radiant temperature, humidity and air movement. For the human factor, the combinations of human metabolic and clothing level were the two other factors that affect human heat generation. These six fundamental factors determine the

overall of human thermal environment. Human heat is also known to be different between a child and an adult, so the responses difference is identified (Ken, 2002).

Humans are homeotherm, a thermoregulation that maintains a stable internal core body temperature to about 37 °C. Exercise or fever may increase the temperature from core body temperature, while exposure to cold may decrease the level of body temperature from the core body temperature. Skin temperature varies greatly in response to metabolism and the environment because of the temperature receptors that held in the skin detect the hot and cold changes (Ken, 2002).

The temperature of the surrounding environment air will vary, this determine the heat flow also the heat transfer between the human body and the surrounding environment air. Human heat is generated through radiation and the radiant temperature is defined as the exchange between human body heat and the environment air (McIntyre, 1980). Human body is defined to respond to six types of radiations and they were the three solar radiations (direct, diffuse, reflect), two thermal radiations (sky, ground) and the thermal radiation emitted from human body (Santee and Gondalez, 1998). Figure 2.1 illustrate the above statement. The body posture and orientation of a human will impact the human responses to the radiation.

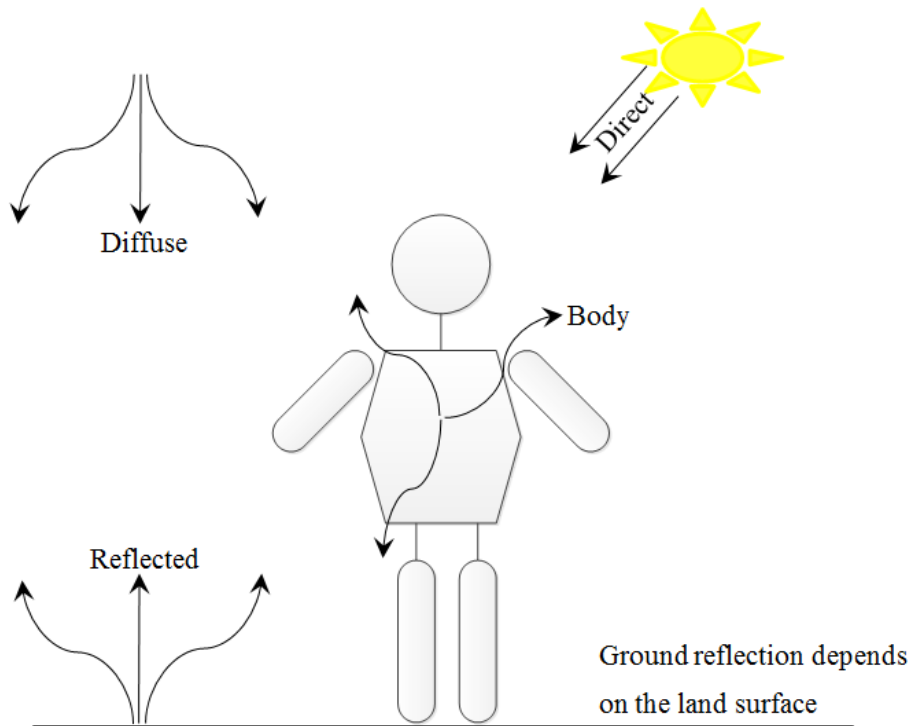

Figure 2.1: Human heat impact to radiation (Santee and Gondalez, 1998)

Air movement across the body influences the heat flow to and from the body also the body temperature. The movement of air will vary in time, space and direction (ISO 7730, 1994). Sweat is heated by the human body, evaporates into vapor then heat is transferred from the body to the environment. These four environment basic factors and two human factors were the six factors of heat generation and distribution within human body.

### 2.3 Human Heat within Bodies

The internal human body temperature is maintained around 37 °C. The heat transfer from the environment and heat generation inside the body is required to be balanced by the amount of heat output produced from the body. If the heat generation is greater than heat output produced from the body, the body temperature will increase and vice versa. Heat generation within bodies, heat transfer, and heat storage were the three terms used to determine human body heat.

The metabolic rate of body,  $M$  provides energy to enable the body to do practical work,  $W$  and the balance is released as heat,  $M-W$ . Heat transfer can be defined by conduction,  $K$ , convection,  $C$ , radiation,  $R$  and evaporation,  $E$ . The combination of all the heat transfer, heat production and losses creates heat storage,  $S$ . When body in constant temperature, the core heat storage rate is zero,  $S=0$ . This means the heat gain or loss will impact the body temperature to be increase or decrease. For example, heat gain will affect the storage to be positive and increases the body temperature (Robert et.al, 2004).

Heat production within the body is related to the body posture, orientation and movement of the person. Generally, oxygen is taken into body, transported by blood to cell to burn the food consumed and most of the energy is released in terms of heat. Energy from a practical work varies the metabolic rate. Researcher found that human body produces an approximation of 56% of total heat that occurs in the internal organs and about 18% in the muscle and skin. Heat production increases during physical activity, and the percentage of

heat produced by mechanical work can rise to as much as 90% as shown in Figure 2.2 (Despopoulos and Silbernagl, 2003).

In 1999, a study has been conducted to determine the human thermal generation and found that each of human contributes in producing heat at the total of 26,296 (W/m<sup>3</sup>) (Fiala et. al.,1999).

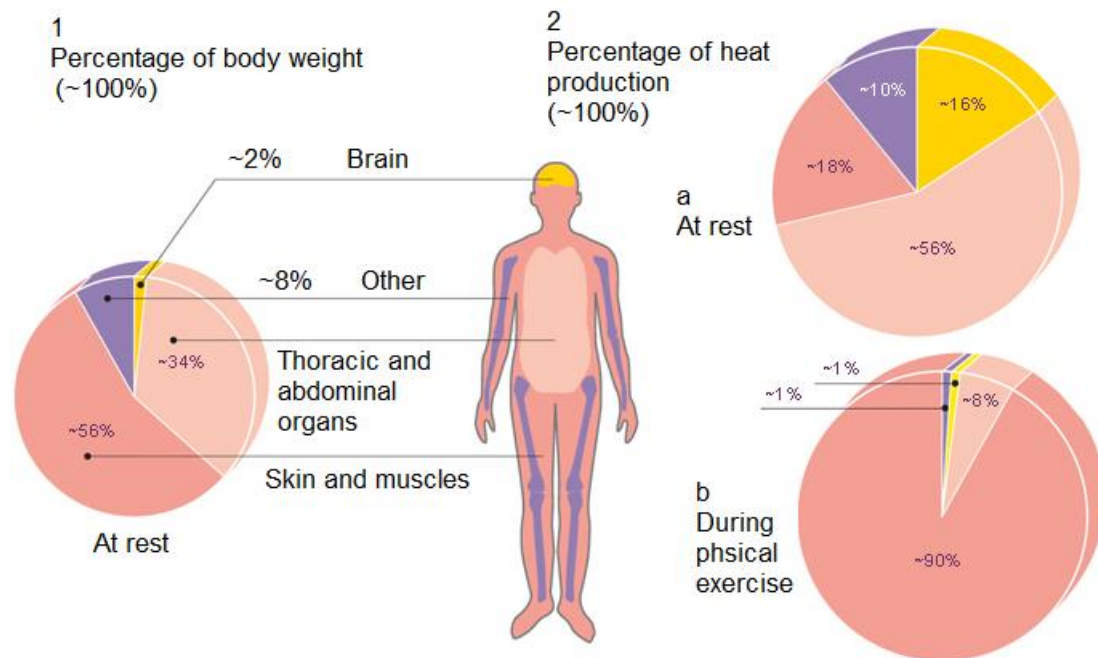

Figure 2.2: Human heat generation within bodies (Despopoulos and Silbernagl, 2003)

Skin temperature can be measured by placing sensors on the skin by using thermocouples, thermistor or by measuring thermal radiation. The heat flow within a small surface such as hand and fingers has been measured by using heat flux sensors or a flexible heat flow devices (Daanen and Wouter, 1992). In Ken modelling analysis, skin temperature is estimated as a constant value is at around 33 °C under constant temperature and 36 °C under heat stress (Ken, 2002).

## **2.4 Principles of Human Heat Generation to Electricity**

Waste heat to electrical energy is based on thermoelectric effect principles. The use of waste heat sources is a very attractive area for the generation of electrical energy. In general, waste heat is produced where some type of work is performed (Miguel et.al. 1999). The principles can be identified in terms of Seebeck effect and Peltier effect.

### **2.4.1 The Seebeck Effect**

Seebeck effect converts the temperature differences directly into electricity. In 1821, Seebeck observed that a temperature difference between two ends of a metal bar create an electrical current in between, with the voltage being directly proportional to the temperature difference (Yarris, 2007).

In Seebeck effect, voltage is generated when there is a temperature difference between the hot and cold at the ends of the semiconductor material. The voltage is named as Seebeck voltage and it is directly proportional to the temperature differential. The constant of proportionality is stated to as the Seebeck coefficient. The operation of Seebeck effect occur when heat is supplied at the one junction causes an electric current to flow in the circuit and electrical power is delivered (Riffat and Ma, 2003).



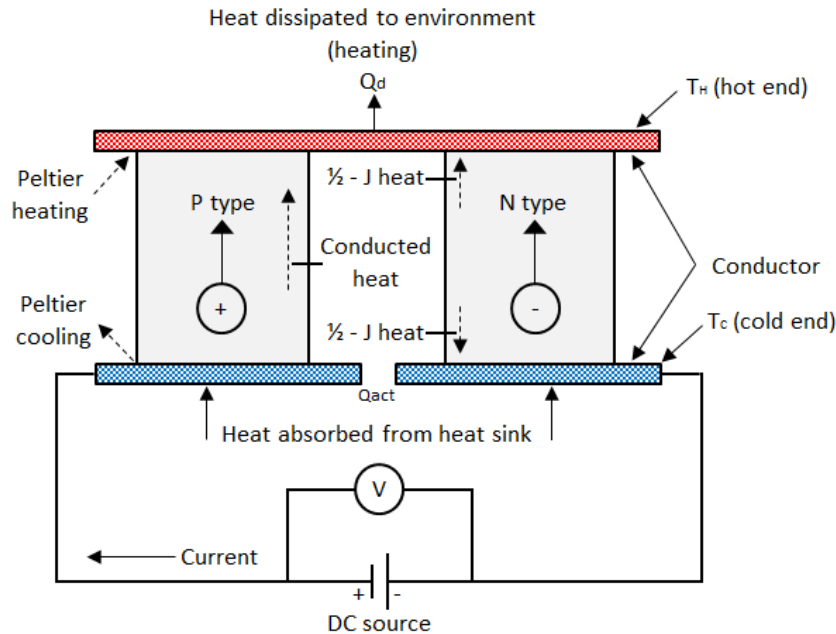

Figure 2.3: Thermoelectric module: Seebeck effect operation

Electrons on the hot side of a material are more energized than on the cold side and these electrons will flow from the hot side to the cold side. Electricity will flow continuously even if the circuit flow is completed. Semiconductor material in pairs, “*p*-type” and “*n*-type” allows them to combine electrically in series to increase voltage and power output (Razak et. al, 2011). Figure 2.3 illustrate the Seebeck effect operation.

### 2.4.2 The Peltier Effect

In 1838, Peltier and Lenz reported the peltier phenomenon during an experiment of electric current flow on two dissimilar conductors. A drop of water is placed at the junction of two bars with two different properties. The electric current varies when it is supplied in either direction. For example, when electric current is supplied in one

direction, the water froze and if in the opposite direction, the frozen water liquefied. The experiment showed that two semiconductor materials with different properties the junction will either dissipate or absorbed heat.

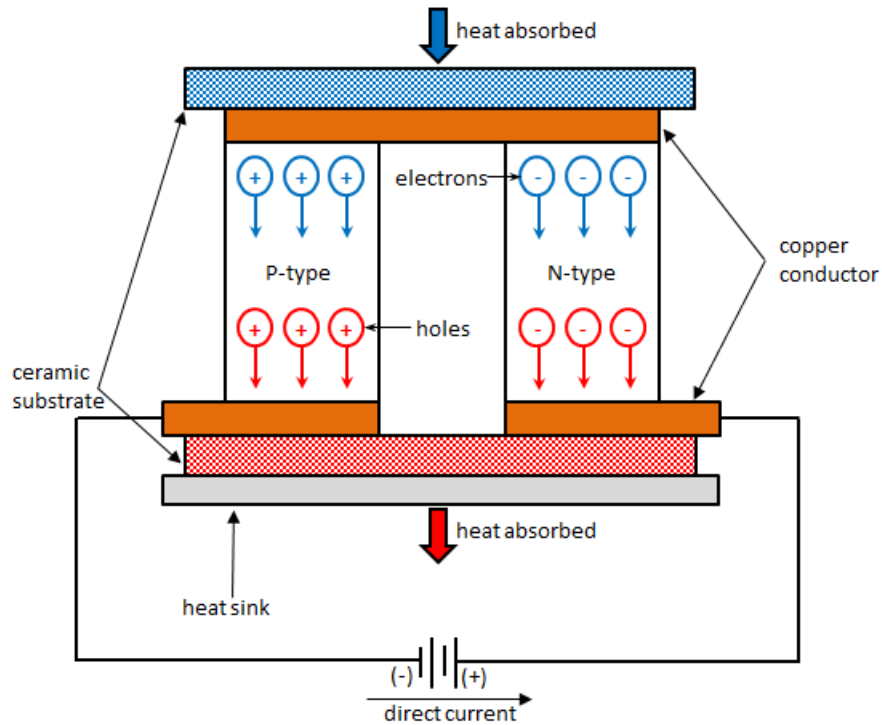

Figure 2.4: Thermoelectric module: Peltier effect operation

Figure 2.4 illustrates the Peltier effect operation. When a voltage is applied, electrons continually flow in and leave the current hole and move to the next available hole. Holes acts as electrical carriers and electron moves in the copper conductors.

The dissipation principles occurs when the electrons leave the p-type and flows into the cold side copper, holes are created in the p-type because electrons bounced out to a higher energy level band to match the energy level of the electrons that are already moving into the copper. Extra energy for the holes creation comes by absorbing heat. The newly

created holes will move downwards to the hot side copper. Electrons from the hot-side copper move into the p-type and drop into the holes dissipate the excess energy as heat (Arun, 2007).

The absorbing heat principle occurs when the n-type provide more electrons to complete the atomic bonds within the crystal lattice. When voltage is applied, these extra electrons are easily moved into the conduction band. Additional energy is required to get the n-type electrons to match the energy level of the incoming electrons from the cold-side copper then the extra energy comes by absorbing heat (Arun, 2007).

When the electrons leave the hot-side of the n-type, they once again can move freely in the copper and drop down to a lower energy level, and release heat in the process. The heat is always absorbed at the cold side of the n-type and p-type elements, and heat is always released at the hot side of thermoelectric element (Arun, 2007).

## **2.5 Energy Harvesting Applications**

Development from natural resources is increasing in energy harvesting for the use in medical for human ease. An energy harvester is define as a small generator of electricity from the environment and the list of energy harvesting method is numerous. There are numerous types of energy harvesting for photovoltaic. One of the known research by University Sains Malaysia researcher is the solar module monitoring expert system for PV system model design (Taib and Shawal, 2003) and another application is the polarized

solar cells (Sebald et. al, 2009). Several researchers found the energy harvesting comes from mechanical vibrations, in the method of electrostatic through a relative movement between electrically isolated charged capacitor planes. The harvested energy generation is from the electrostatic force between the plates (Peano and Tamboso, 2005). Mechanical vibration can also be generated through electromagnetic method. Electromagnetic induction arising, form the rotative or linear motion between a magnetic flux and a conductor (Jones et. al., 2004). Another example is form by piezoelectric. The active materials were used to convert a mechanically stressed into energy (Badel et. al., 2005). The energy harvesting from human body can be summarized in the below figure 2.5.

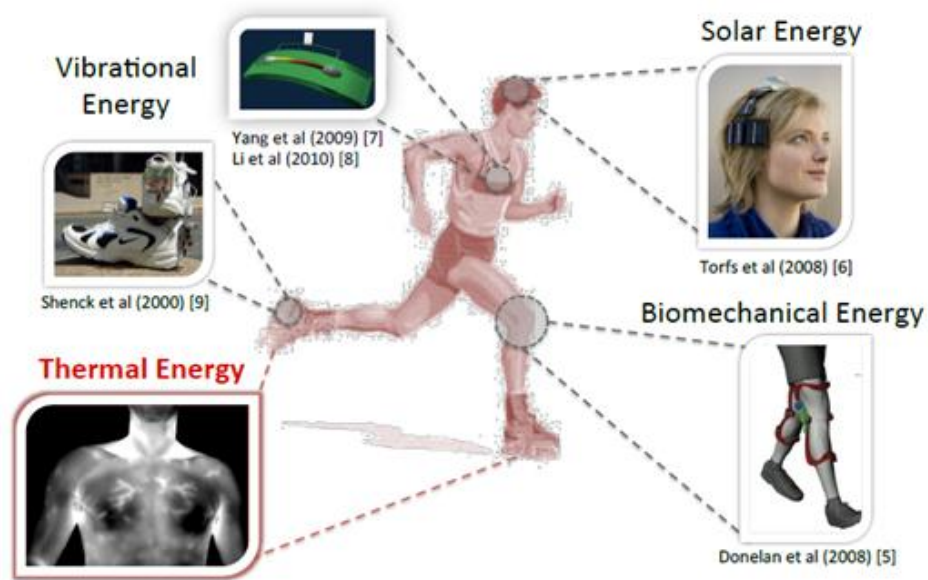

Figure 2.5: Summary of natural resources energy harvesting from the human body (Chen, 2011)

## 2.6 Human Heat Energy Harvesting Applications

Thermal energy harvesting from body heat is useful for powering low-power electronics devices. In human heat energy harvesting, thermoelectric generator (TEG) is a commonly used device to convert the human heat to electricity. Human body can produce approximately  $10\text{--}30 \mu\text{W}/\text{cm}^2$  of electrical power in moderate climate, on 24 hours in average. This thickness and size affect the produced output power. The thicker the TEG, the better the power generation, while the larger the TEG, the less power per unit area is produced (Leonov and Vullers, 2009).

In 2006, a wearable electronics self-powered for medical application that is shown in Figure 2.6, using human body heat were presented. The first project was the combination of ambient light and human heat to produce the self-powered wearable device. The research is enhanced with other methods of implementation by using TEG in transferring human heat to electricity. The first practical demonstration of body-powered medical devices is a wireless pulse oximeter  $\text{SpO}_2$  sensor that has been designed, fabricated, and tested on people. By using the device, oxygen content in arterial blood is measured. TEG is used to power up a watch-size device with a minimal power production of about 100 W at night and with a variation within 100–600 W range during the day (Leonov and Vullers, 2006). Figure 2.6 illustrates the application.

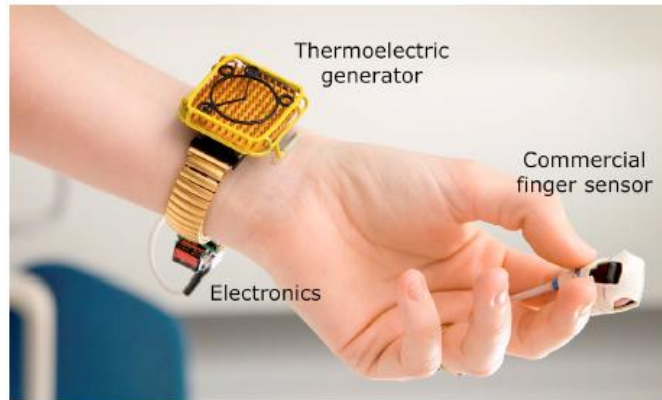

Figure 2.6: Body-powered wireless pulse oximeter (Leonov and Vullers, 2006)

In 2007, a body-powered device electroencephalography (EEG) is invented as per shown in Figure 2.7. The researcher found that the forehead is a convenient location for a TEG on the head. By using low power application specific integrated circuit (ASIC), the power consumption is reduced and the device able to powered through human heat. EEG headband power consumption production is 2.5 mW and the output stabilized voltage ranged at 2 V and 2.8 V (Yazicioglu et. al., 2007).

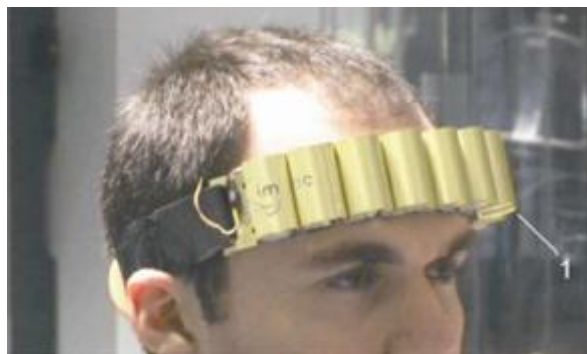

Figure 2.7: Body powered EEG headband; TEG (Yazicioglu et. al., 2007)

In 2008, EEG headband is improved by combining the TEG with the photovoltaic (PV) cells shown in Figure 2.8 is invented. The design is with the PVs covered the TEG and the dual power generation improved without the changes in weight and size. PV cells are much lighter and able to provide additional power; this advantage able to reduce the TEG thickness but PV cells is unstable as it is depending on ambient lights. EEG headband power consumption production is 1.5 mW during daytime (Yazicioglu et. al., 2008).



Figure 2.8: Body-powered EEG headband; TEG and PV cells (Yazicioglu et. al., 2008)

In 2009, an implantable neural recording system is proposed. Human tissue warmth is used to convert to electricity. The proposed circuit in the research shown in Figure 2.9 is to create the neural signal ranged from 50  $\mu\text{V}$  to 500  $\mu\text{V}$  by using thermoelectric power concept. A thin film generator MPG-D602 is used in this application. The generated power consumption is at approximate 9.22  $\mu\text{W}$  (Hmida et.al, 2009).

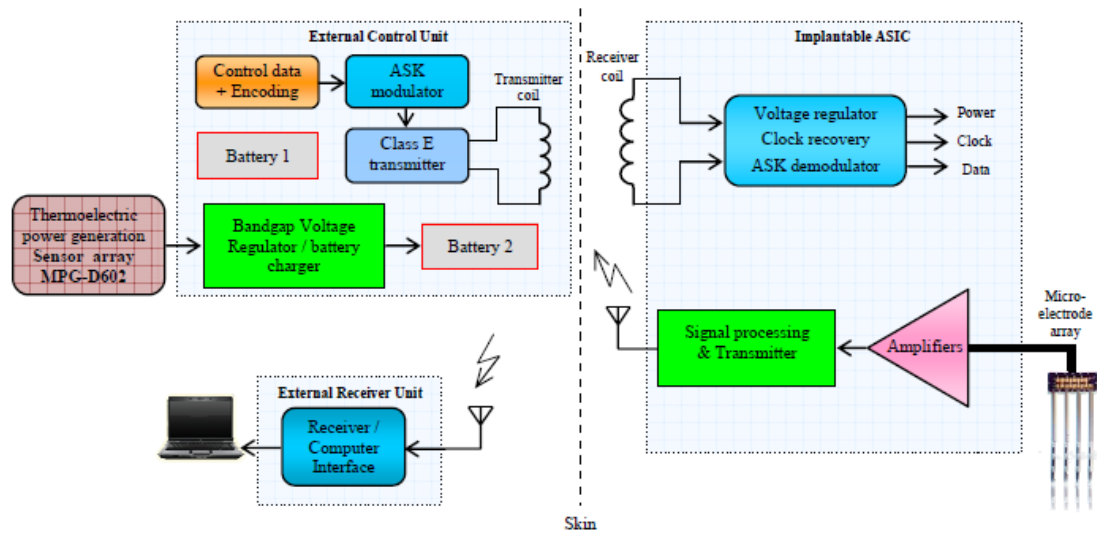

Figure 2.9: Neural recording system through Thermoelectric Power (Hmida et.al, 2009)

In 2010, a group of Asian researchers fabricated a thermoelectric power generator shown in Figure 2.10, to convert human body heat to electricity. The generator is made of a chip with 1 cm in square size. It consist of more than 30 K thermocouples in the generator. The thermocouples were arranged to detect the temperature difference between the junctions to produce an output voltage. The power output generation is  $1.3 \mu\text{W}$  and able to generate 16.7 V (Jin et.al, 2010).

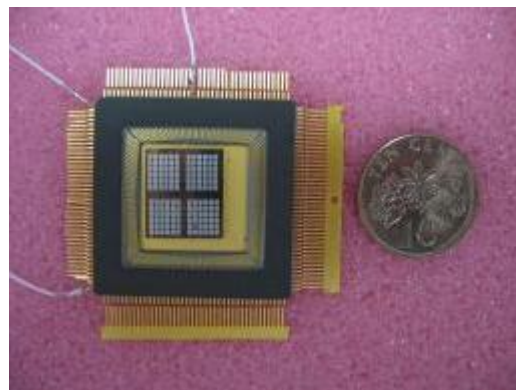

Figure 2.10: CMOS MEMS based thermoelectric device (Jin et.al, 2010)



In 2011, Korean researchers had used a TEG that composed of polydimethylsiloxane (PDMS) substrate and thermocouples. The material shown in Figure 2.11 is flexible and has low thermal conductivity. Figure 2.12 illustrate the application of the TEG and the TEG is pasted on human body to generate electricity. The generated power consumption production during ambient temperature is 50 nW while the voltage is at 5 mV with 10  $\mu$ A (Sung et. al., 2011).

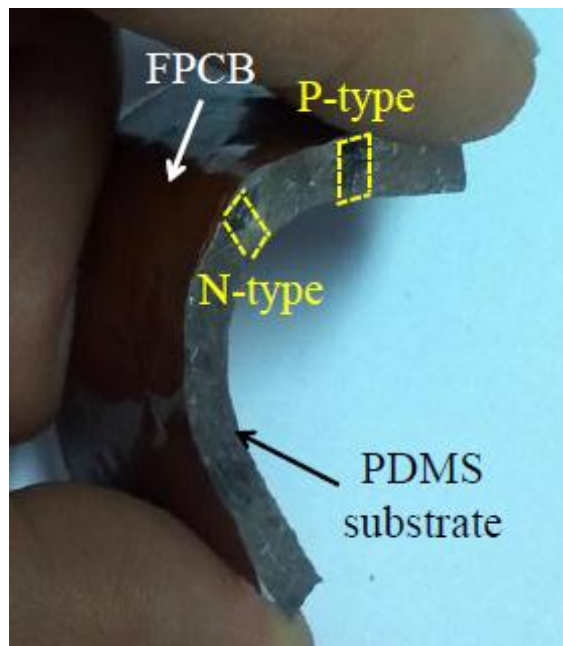

Figure 2.11: A flexible TEG composed of polydimethylsiloxane (PDMS) substrate and thermocouples (Sung et. al., 2011)

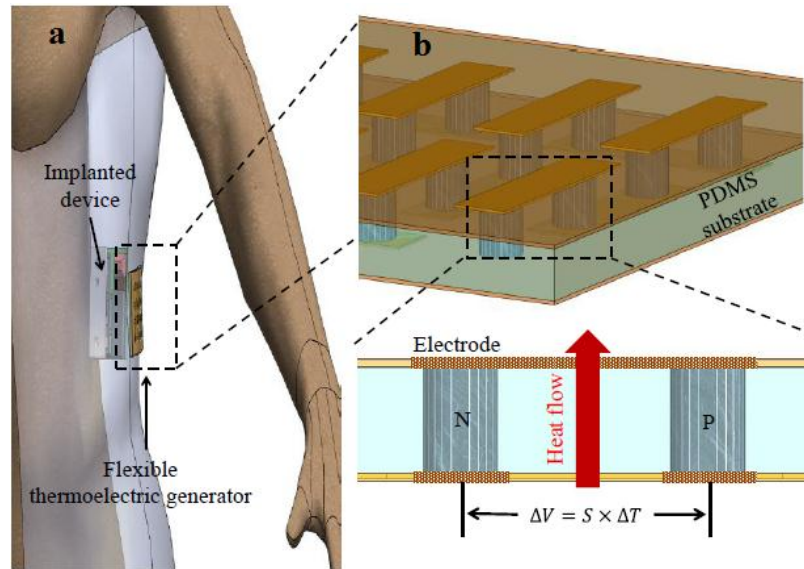

Figure 2.12: (a) Flexible TEG attached to body, (b) Exploded view of the TEG

(Sung et. al., 2011)

In 2012, a carbon nanotube (CNT) or polymer materials that is shown in Figure 2.13 which is also named as Power Felt. It is a low cost, ease of production, and flexibility material is produced. This application can be used as to power up a wristwatch from human heat and other wearable application such as winter jackets to power electronic devices, such as an iPod. This material is able to convert both human body heat and movement to electricity. The material is experimented to have 72 layers with the temperature difference of 50 K. It is able to generate maximum power output at 137 nW (Hewitt, et al, 2012).



Figure 2.13 Carbon Nanotube Materials (Hewitt, et al, 2012)

In 2013, a flexible and inexpensive design is presented by using human gesture through rubbing, sliding, touching and tapping to convert to electrical energy. This energy will be used to display a word on a paper as shown in Figure 2.14. These gestures not only able to display word it is also able to light-up an LED, buzzers and IR transmitter. It uses a thin surface of PTFE (polytetrafluoroethylene) or known as teflon to create an opposite polarity charges during the rubbing gesture. The average peak power is measured at 44 mW (Karagozler et, al, 2013).



Figure 2.14: Human heat energy harvesting through hand rubbing and display on electronically in paper (Karagozler et, al, 2013)

In 2014, The Korea Advanced Institute of Science and Technology (KAIST), introduces the latest TEG technology on glass fabric as shown in Figure 2.15. The fabric is a wearable, flexible and light. The generated power consumption is approximately 40 mW at the temperature difference of 31 °F between human skin and the environment (Yoon, 2014).



Figure 2.15: Flexible wrist band TEG (Yoon, 2014)

## 2.7 Summary

Table 2.1 present the summary on human heat energy harvesting and its application. Most of the research is on medical field. In this research, different area of analysis of human heat generation to electricity is studied, and the final output is for commercial usage such as LED indicator. The proposed design methodology and implementation will be discussed in details in Chapter 3.

Table 2.1: Summary on the on-going research on human heat detection and its application

Year	Device used	Application
2006	TEG : wearable pulse oximeter electronics elf-powered	Medical application
2007	body-powered device electroencephalography : EEG headband	Medical application
2008	TEG with the photovoltaic (PV) cells : EEG headband	Medical application
2009	Thin film generator MPG-D602	Electronic application
2010	CMOS MEMS based thermoelectric device	Electronic application
2011	TEG polydimethylsiloxane (PDMS) substrate and thermocouples	Medical/military application
2012	Carbon Nanotube (CNT) or polymer	Electronic application
2013	PTFE (polytetrafluoroethylene) or teflon	Electronic application
2014	TEG glass fabric	To be determined

## CHAPTER 3

### DESIGN METHODOLOGY AND IMPLEMENTATION

#### 3.1 Introduction

This chapter describes the methodology for the whole structure of experimental setup with the respective consideration for the proposed design. This section explains the general concept design of the overall system to convert human heat to electricity. The overall prototype design block diagram is illustrated as in Figure 3.1, which consists of the human heat as input, the thermoelectric module or Peltier module, heat sink, the voltage booster and the LED output indicator. Each of it will be explained in the next section.

In this research, the temperature of different human body parts will be measured by using Liquid Crystal thermometer. The human body parts will be placed on top of the peltier module and a heat sink on the other side. The human heat generation from the human body location is proven through the Seebeck effect. The electricity is generated due to the temperature difference between the cold surface and the hot surface. The voltage generated from Peltier module is then supplied to voltage booster circuit to boost the small energy harvested from human body heat to a higher voltage in order to turn on the