UNIVERSITI SAINS MALAYSIA

1st. Semester Examination
2004/2005 Academic Session

October 2004

EAS 663/4 – Dynamics and Stability of Structures

Duration: 3 hours

Instructions to candidates:

1. Ensure that this paper contains **EIGHT (8)** printed pages, including appendices, before you start your examination.
2. This paper contains **FIVE (5)** questions. Answer **ALL (5)** questions.
3. All questions **MUST B** answered in English.
4. All questions **MUST BE** answered on a new sheet.
5. All questions carry equal marks.
6. Write the answered question numbers on the cover sheet of the answer script.

1. (a) List two characteristics that distinguish structural dynamic problems from static ones. (4 marks)
- (b) Define viscous damping. Sketch the displacement response, (v) versus (t) of undamped and damped SDOF systems for free vibration. Does the natural period of vibration, T , change with the present of damping? (6 marks)
- (c) Figure 1.0 shows a model of spring-mass SDOF system that is subjected to a harmonic excitation, $p(t) = 50 \cos 10t$ N. The weight of the mass block is 150 kN and the spring stiffness, $k = 7000$ N/m. Assume the damping of the system is equal to 5% of the critical damping. Determine the total displacement response of the system which is given by the following equation:

$$v(t) = V \cos(\Omega t - \alpha) + e^{-\zeta \omega t} (A_1 \cos \omega_d t + A_2 \sin \omega_d t)$$

$$V = \frac{v_r}{\sqrt{(1-r^2)^2 + (2\zeta r)^2}}$$

where ω : natural circular frequency of the system and v_0 : static displacement due to p_0 .

(10 marks)

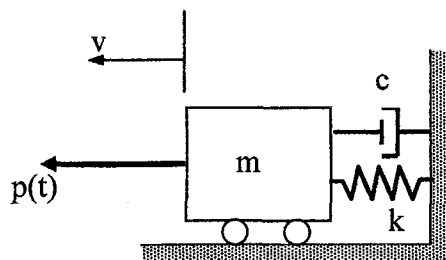

Figure 1.0

2. (a) Duhamel Integral is normally used for the evaluation of a linear SDOF system subjected to arbitrary time varying force. Define the underlined term with the help of a graph Force, (P) versus (t) . (5 marks)
- (b) Figure 2.0 shows a spring-mass model for 2DOF system under free vibration. Derive the equations of motion for the system. (5 marks)

(5 marks)

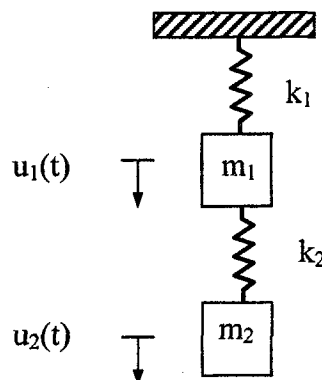

Figure 2.0 (a)

(c) The water tower as shown in Figure 2.0 (b) weighs 700kN when filled with water is subjected to step force with rise time [Figure 2.0 (c)]. It is observed that a horizontal jack force of 30kN is required to displace the tower top by a distance of 20mm. Estimate the maximum lateral displacement response due to dynamic forces. The constant phase is given by the following equation:

$$v(t) = v_0 \left\{ 1 + \frac{1}{\omega t_r} [A \sin(\omega(t - t_r) + \alpha)] \right\}$$

$$A = \sqrt{(1 - \cos \omega t_r)^2 + (\sin \omega t_r)^2}, \quad \tan \alpha = -\frac{\sin \omega t_r}{(1 - \cos \omega t_r)}$$

where ω : natural circular frequency of the system, v_0 : static displacement due to p_0 , v_{max} : maximum response and T_n : natural period of vibration. A plot of $R_d (= v_{max} / v_0)$ versus t_r / T_n is shown in Figure 2.0 (d). Comment on the effect of ratio t_r / T_n on R_d , without carrying out any "exact" dynamic analysis.

(10 marks)

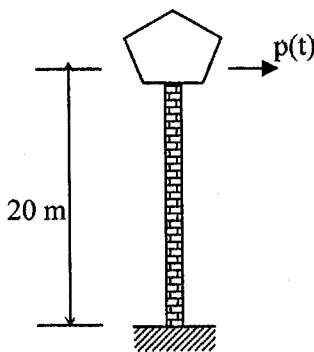

Figure 2.0 (b)

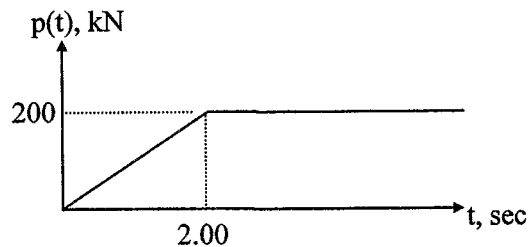

Figure 2.0 (c)

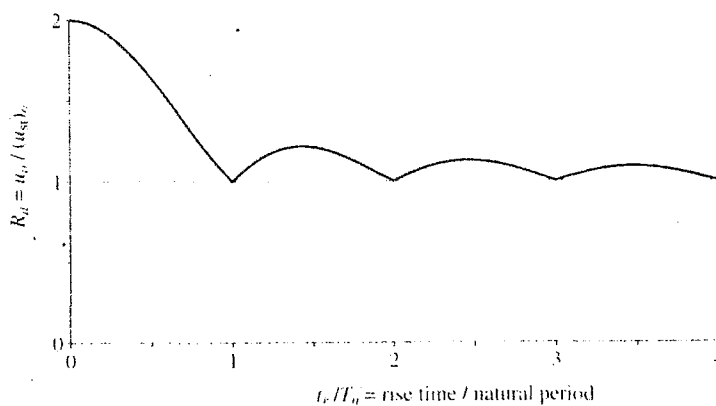

Figure 2.0 (d)

3. (a) By using an axially loaded and perfectly straight column with both ends pinned, explain the concepts of stable, unstable and neutral equilibrium. (6 marks)

- (b) Figure 3.0 shows an initially straight column subjected to an axial load P which acts at an eccentricity e from the centroidal axis of the column. Obtain the following relation between mid-height deflection δ and ratio P/P_E where P_E : Euler buckling load $=\pi^2EI/L^2$:

$$\delta = e \left[\sec \left(\frac{\pi}{2} \sqrt{\frac{P}{P_E}} \right) - 1 \right]$$

Sketch a plot of P/P_E versus δ for three different values of e .

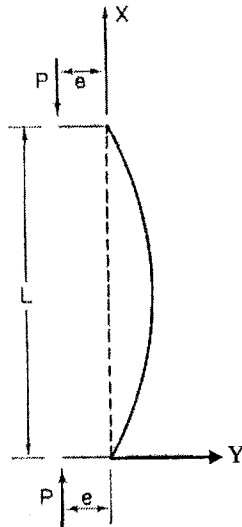

Figure 3.0

Sketch also on the same plot the graph representing the behaviour of an initially straight column with $e=0$. Based on the graph, discuss the effect of imperfection of load on the behaviour of an axially loaded column. (14 marks)

4. (a) Derive the following fourth order differential equation for beam-column :

$$y^{iv} + k^2 y'' = 0, \quad k^2 = \frac{P}{EI}$$

where y : lateral displacement of beam-column, P : axial force acting at both ends of beam-column, EI : flexural rigidity, $(\dots)'' = d^2(\dots)/dx^2$ and $(\dots)^{iv} = d^4(\dots)/dx^4$. Next, explain how the above fourth order differential equation is used to determine the critical load of beam-column with different end conditions. You are required to specifically point out in your explanation how starting from the fourth order differential equation, one can arrive at the eigenvalue problem which can be used to solve for the critical load of beam-column with different end conditions. (10 marks)

(b) A simple two-bar frame is shown in Figure 3.0. A load P acts at end B of vertical member AB . Both supports A and C are fixed. Obtain the effective length L_e for the two-bar frame by using the following equation for an elastically restrained column:

$$(1 - \lambda_1 - \lambda_2 - \lambda_1 \lambda_2 \Phi^2) \Phi \sin \Phi + (2 + \lambda_1 \Phi^2 + \lambda_2 \Phi^2) \cos \Phi - 2 = 0$$

where $\lambda_1 = EI/(\alpha_1 L)$, $\lambda_2 = EI/(\alpha_2 L)$, $\Phi = kL$, $k^2 = P/EI$, EI : flexural rigidity, L : length of column, α_1, α_2 : rotational stiffness of end 1 and 2 of column being studied, respectively. Justify your solution for the effective length obtained by using information provided in Table 1.0 (see Appendix 1).

(10 marks)

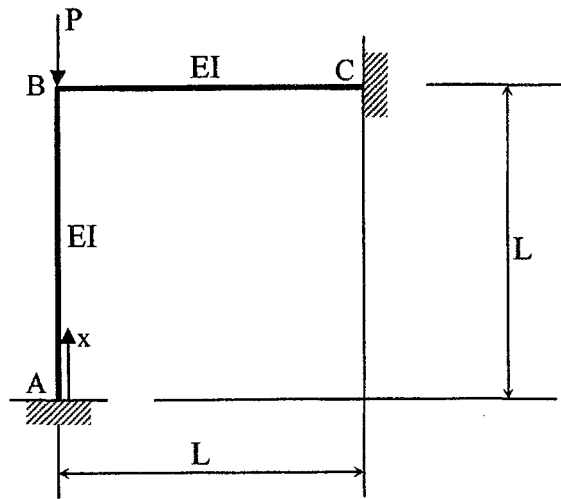

Figure 3.0

5. (a) Figure 4.0 (a) and (b) show braced and unbraced frames, respectively. For each frame, sketch the buckling mode corresponding to the lowest critical load. Using suitable eigenvalue analysis, it can be shown that effective length factor K for

- i. column in braced frame is $K < 1.0$ and
- ii. column in unbraced frame is $K > 1.0$

Justify the above conclusions by referring to behavior of columns with other standard end conditions.

(6 marks)

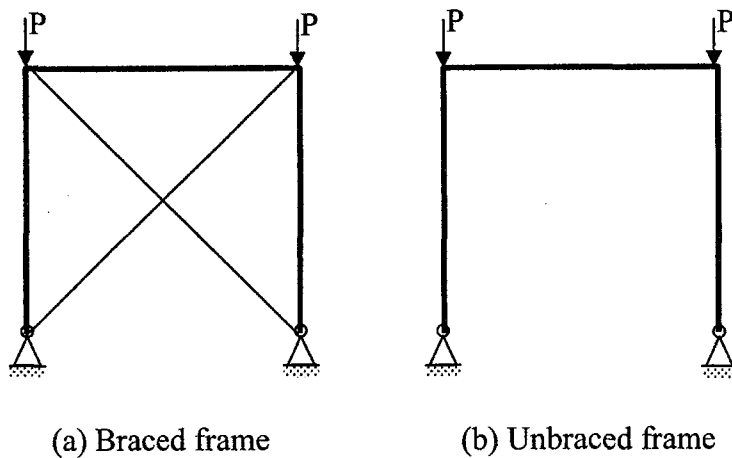

Figure 4.0

(b) Slope deflection equations for a beam-column are given as follows :

$$M_A = \frac{EI}{L} (s_{ii}\theta_A + s_{ij}\theta_B)$$

$$M_B = \frac{EI}{L} (s_{ji}\theta_A + s_{jj}\theta_B)$$

where s_{ii} , $s_{ij}(=s_{ji})$, s_{jj} are stability functions and M_A , M_B , θ_A and θ_B are as shown in Figure 5.0.

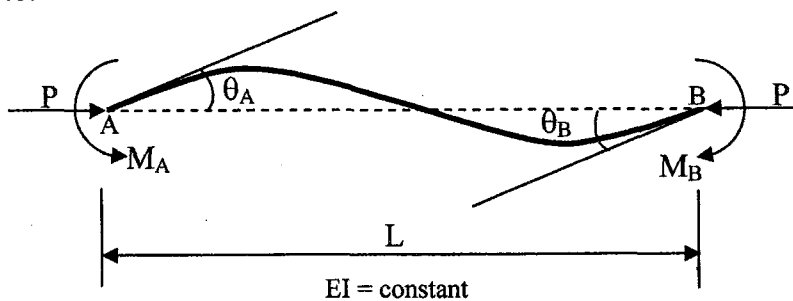

Figure 5.0

Making use of the previous set of slope-deflection equations and the following assumptions for a member in a braced frame:

- i. All members are prismatic and behave elastically
- ii. The axial forces in the beam are negligible
- iii. All columns in a storey buckle simultaneously
- iv. At a joint, the restraining moment provided by the beams is distributed among the columns in proportion to their stiffness
- v. At buckling, the rotations at the near and far ends of the beams are equal and opposite

show the process of deriving the following eigenvalue problem for the determination of effective length of a column in a braced frame :

$$\begin{bmatrix} s_{ii} + \frac{2}{G_A} & s_{ij} \\ s_{ij} & s_{jj} + \frac{2}{G_B} \end{bmatrix} \begin{Bmatrix} \theta_A \\ \theta_B \end{Bmatrix} = \begin{Bmatrix} 0 \\ 0 \end{Bmatrix}$$

where G_A , G_B are defined as follows :

$$G_A = \frac{\sum_A (I/L)_{column}}{\sum_A (I/L)_{beam}} = \frac{\sum \text{of column stiffness meeting at end A}}{\sum \text{of beam stiffness meeting at end A}}$$

$$G_B = \frac{\sum_B (I/L)_{column}}{\sum_B (I/L)_{beam}} = \frac{\sum \text{of column stiffness meeting at end B}}{\sum \text{of beam stiffness meeting at end B}}$$

You are required:





- i. to show the equations involved in arriving at the eigenvalue problem
- ii. to show a suitable sketch showing the column in a braced frame
- iii. to state how the assumptions listed above are used in the derivation

(14 marks)

Appendix 1

(a)

Table 1 Effect of end condition on critical load

Boundary conditions	Critical load P_{cr}	Deflection mode shape	Effective length KL
Simple support-simple support	$\frac{\pi^2 EI}{L^2}$		L
Clamped-clamped	$4 \frac{\pi^2 EI}{L^2}$		$1L$
Clamped-simple support	$2.04 \frac{\pi^2 EI}{L^2}$		$0.70L$
Clamped-free	$\frac{1}{4} \frac{\pi^2 EI}{L^2}$		$2L$

(b) Slope deflection equations for a beam member without relative end translation and in-span lateral load:

$$M_{AB} = 2 \frac{EI}{L} (2\theta_A + \theta_B)$$

$$M_{BA} = 2 \frac{EI}{L} (\theta_A + 2\theta_B)$$

