

**THE MODELLING OF TYRE ROTATION BEHAVIOUR WITH  
TYRE PRESSURE MONITORING SYSTEM**

**GOH YIK CHOONG**

**UNIVERSITI SAINS MALAYSIA**

**2017**

**THE MODELLING OF TYRE ROTATION BEHAVIOUR WITH  
TYRE PRESSURE MONITORING SYSTEM**

**by**

**GOH YIK CHOONG**

**Thesis submitted for partial fulfillment of the requirement  
for the degree of Master of Science  
(Microelectronic Engineering)**

**August 2017**

## **ACKNOWLEDGEMENT**

First and foremost, I would like to express my deep gratitude to research supervisor Dr. Mohamed Fauzi Bin Packeer Mohamed, for his patient guidance, enthusiastic encouragement and constructive suggestion on my research planning and development. His willingness to give his time, starting from first semester before the actual research start date. In addition, his professionalism and passion that supported me throughout the Master program until completion is much appreciated.

Besides that, I would also like to thank Intel technology as well as my direct superior Mr. Lim Choon Aun for offering me the opportunity enroll in this postgraduate micro-electronic master program and his support is much appreciated. Apart from that, I wish to thank various people from USM and Usains that were involved in contributing to this Mixed-mode partnership master program and making it a success.

Last but not least, warmest thought to my lovely family members for supporting my decision in every milestone in my life. Without their continuous support, I would not have the opportunities to achieve success, especially during the challenging period to carry on my research work.

# TABLE OF CONTENTS

ACKNOWLEDGEMENT .....	i
TABLE OF CONTENTS.....	ii
LIST OF TABLES .....	v
LIST OF FIGURES .....	vii
LIST OF ABBREVIATIONS.....	x
ABSTRAK.....	xii
ABSTRACT.....	xiii
CHAPTER 1 INTRODUCTION .....	1
1.1 Background .....	1
1.2 Problem Statements.....	3
1.3 Research Objectives .....	4
1.4 Research Scope .....	4
1.5 Research Contribution.....	5
1.6 Thesis Outline .....	6
CHAPTER 2 LITERATURE REVIEW .....	7
2.1 Introduction.....	7
2.2 Existing Tyre Monitoring Technologies .....	7
2.2.1 Direct and Indirect Measurements.....	7
2.2.2 Survey and Comparison of Tyre Monitoring Technologies.....	9
2.3 Type Of Tyre Construction, Improper Inflations And Tyre Depth Measurement .....	11
2.3.1 Bias-ply and Radial Tyre Construction .....	11
2.3.2 Tyre Failure Caused by Improper Inflation.....	14
2.4 Wireless Technologies .....	16

2.4.1 Overview of Technologies Survey in Wireless Communication for Vehicle .....	16
2.4.2 Operation Mode .....	17
2.4.3 Frequency, Data Rate and Range .....	18
2.4.4 Power Consumption .....	18
2.5 Review on Tyre Rotation Behaviour Model .....	19
2.5.1 Tyre Rotation under Different Revolution .....	19
2.5.2 Tyre Rotation under Different Inflation .....	22
2.5.3 Data Transmission in Vehicle.....	25
2.6 Chapter Summary.....	27
CHAPTER 3 METHODOLOGY .....	30
3.1 Introduction .....	30
3.1 Methodology of Project.....	30
3.2 Block Diagram of Tyre Pressure Monitoring System.....	31
3.2.1 Transmitter Module .....	33
3.2.2 Receiver Module.....	33
3.3 Flow Chart.....	33
3.4 Selection Of Hardware .....	37
3.4.1 Pressure Sensor.....	37
3.4.2 Inertia Measurement Unit (IMU) .....	38
3.4.3 Wireless technologies .....	39
3.4.4 Bluetooth .....	40
3.4.5 Microcontroller.....	41
3.5 Design & Experiment Setup For Tyre Pressure Monitoring System .....	42
3.5.1 Design of Transmitter Module inside the Tyre .....	43
3.5.2 Transmitter and Receiver Module Circuit Design.....	45

3.5.3 Experimental Setup.....	48
3.5 Chapter Summary.....	53
CHAPTER 4 RESULTS AND DISCUSSIONS.....	54
4.1 Overview .....	54
4.2 Modelling Of Vehicle Rotation Behaviour and Vehicle Distance Traveled Calculation ...	54
4.2.1 Accelerometer Performance Based On Wheel Rotation with Speed Variation .....	54
4.2.2 Accelerometer Performance Based On Wheel during Braking / Stop Condition .....	57
4.2.3 Accelerometer Performance Based On the Wheel Rotation Counter And Distance Travel Calculation .....	60
4.3 Monitoring On Pneumatic Pressure inside Tubeless Tyre .....	64
4.3.1 Investigate From Atmospheric Pressure Level to Project Specification .....	64
4.3.2 Pressure Sensor Reading Accuracy Test by Reverse Engineering.....	69
4.4 Data Transmission Quality on Bluetooth Connection.....	72
4.5 Chapter Summary.....	75
CHAPTER 5 CONCLUSION AND FUTURE WORKS.....	77
5.1 Conclusion.....	77
5.2 Future Works.....	78
REFERENCES .....	79
APPENDIXES .....	1

## LIST OF TABLES

<b>Table 1.1</b> Statistic of General Road Accident Data in Malaysia [1].....	<b>1</b>
<b>Table 1.2</b> Statistic of Road Deaths by Type of Vehicle [2].....	<b>2</b>
<b>Table 1.3</b> Vehicle Related Critical Reasons [3].....	<b>3</b>
<b>Table 2.1</b> The Comparison of Tyre Monitoring Technologies Working Principle [13, 14].....	<b>10</b>
<b>Table 2.2</b> Performance and Differences of Bias-ply and Radial Technologies [15].....	<b>12</b>
<b>Table 2.3</b> Comparison of Wireless network parameters that used in In-vehicle transmission [24].....	<b>18</b>
<b>Table 2.4</b> Energy Consumption of several wireless standard in different stages [26].....	<b>19</b>
<b>Table 2.5</b> The Measured RSSI according to sensor position [35].....	<b>25</b>
<b>Table 2.6</b> Variation of packet received at different speed [36].....	<b>27</b>
<b>Table 2.7</b> Compilation of Limitation, Gap and Further Improvement from Research papers .....	<b>28</b>
<b>Table 3.1</b> Comparison of absolute pressure sensors .....	<b>37</b>
<b>Table 3.2</b> Comparison of IMU Sensors [38].....	<b>38</b>
<b>Table 3.3</b> Comparison of wireless technologies [39].....	<b>39</b>
<b>Table 3.4</b> Comparison bluetooth module available in the market [40].....	<b>40</b>
<b>Table 3.5</b> Comparison of Arduino Version Available In Market [41].....	<b>41</b>
<b>Table 3.6</b> Software Used in project development .....	<b>42</b>
<b>Table 4.1</b> Accelerometer result of different speed .....	<b>55</b>

<b>Table 4.2 Z-axis behaviour during brake .....</b>	<b>58</b>
<b>Table 4.3 Description of tyre running condition .....</b>	<b>59</b>
<b>Table 4.4 Experiment results of rotation counter with different speed .....</b>	<b>60</b>
<b>Table 4.5 Differential Voltage reading respect to pressure rereading .....</b>	<b>66</b>
<b>Table 4.6 Parameter uses to calculate the equation of straight line .....</b>	<b>67</b>
<b>Table 4.7 Pressure sensor readings by reverse engineering method .....</b>	<b>69</b>
<b>Table 4.8 RSSI from multiples transmitter direction .....</b>	<b>72</b>
<b>Table 4.9 Transmitter position in rear and front tyre.....</b>	<b>73</b>
<b>Table 4.10 RSSI with different rotation speed .....</b>	<b>75</b>

## LIST OF FIGURES

<b>Figure 2.1 Sensor Placement for Direct System [9].....</b>	<b>8</b>
<b>Figure 2.2 Operation Principle for Indirect System [12].....</b>	<b>8</b>
<b>Figure 2.3 Tyre Monitoring Technology Categories .....</b>	<b>9</b>
<b>Figure 2.4 Bias-ply construction [15].....</b>	<b>11</b>
<b>Figure 2.5 Radial construction [15].....</b>	<b>12</b>
<b>Figure 2.6 Description of radial tyre components [16].....</b>	<b>14</b>
<b>Figure 2.7 Tyre Failures Caused by Improper Inflation [18].....</b>	<b>15</b>
<b>Figure 2.8 Wear Bar inside the Tyre Thread [22].....</b>	<b>16</b>
<b>Figure 2.9 Calculation of Wheel Speed [28].....</b>	<b>20</b>
<b>Figure 2.10 Measured and estimated vehicle speed according to time [29].....</b>	<b>20</b>
<b>Figure 2.11 Frequency of rotation compared to oscillation [31].....</b>	<b>21</b>
<b>Figure 2.12 Traction ratio against slip different inflation pressure [32].....</b>	<b>22</b>
<b>Figure 2.13 Straight-line braking with respect to inflation pressure and acceleration [34] .....</b>	<b>24</b>
<b>Figure 2.14 The Position of TPMS sensors and monitoring device [35].....</b>	<b>25</b>
<b>Figure 2.15 LabVIEW GUI with speed variation [36].....</b>	<b>26</b>
<b>Figure 3.1 Methodology of project .....</b>	<b>31</b>
<b>Figure 3.2 System flow of sensing and processing module .....</b>	<b>32</b>
<b>Figure 3.3 Transmitter module sequence flow chart .....</b>	<b>35</b>
<b>Figure 3.4 Receiver and Monitoring module sequence flow chart .....</b>	<b>36</b>

<b>Figure 3.5 Selected Honeywell pressure sensor [37] .....</b>	<b>37</b>
<b>Figure 3.6 Selected IMU [38] .....</b>	<b>38</b>
<b>Figure 3.7 HC-05 Bluetooth Module [40].....</b>	<b>40</b>
<b>Figure 3.8 Arduino Pro Mini 328 [41].....</b>	<b>41</b>
<b>Figure 3.9 Side view (left) and top view (right) of transmitter module placement .</b>	<b>44</b>
<b>Figure 3.10 Transmitter module (zoom in) .....</b>	<b>45</b>
<b>Figure 3.11 (a) Transmitter module schematic design .....</b>	<b>46</b>
<b>Figure 3.11 (b) Transmitter module circuit diagram .....</b>	<b>46</b>
<b>Figure 3.12 (b) Receiver module schematic design .....</b>	<b>47</b>
<b>Figure 3.12 (b) Receiver module circuit diagram .....</b>	<b>48</b>
<b>Figure 3.13 Pitch, roll and yaw behaviour .....</b>	<b>49</b>
<b>Figure 3.14 Single axis accelerometer rotation .....</b>	<b>50</b>
<b>Figure 3.15 Tyre dimension index [42] .....</b>	<b>51</b>
<b>Figure 3.16 Multiples direction of transmitter .....</b>	<b>52</b>
<b>Figure 3.17 Multiples direction of transmitter .....</b>	<b>53</b>
<b>Figure 4.1 The graph at 25 rounds per minute, rpm .....</b>	<b>56</b>
<b>Figure 4.2 The graph at 50 rounds per minute, rpm .....</b>	<b>57</b>
<b>Figure 4.4 Behaviour of Z-axis at tyre acceleration, sharp brake and stopped condition .....</b>	<b>59</b>
<b>Figure 4.6 Acceleration versus Time graph based on test runs .....</b>	<b>61</b>
<b>Figure 4.7 Technique for wheel rotation identification .....</b>	<b>62</b>
<b>Figure 4.8 Algorithm for rotation calculation .....</b>	<b>63</b>
<b>Figure 4.10 Output reading show in terminal emulator program .....</b>	<b>64</b>

<b>Figure 4.11 Histogram of Absolute Pressure versus Pressure Gauge Reading .....</b>	<b>65</b>
<b>Figure 4.12 Gauge pressure reading at 156 kpa .....</b>	<b>68</b>
<b>Figure 4.13 Graph of Pre-set Pressure Reading versus Sensor Reading .....</b>	<b>70</b>
<b>Figure 4.14 Real-time pressure measurement on LCD .....</b>	<b>71</b>
<b>Figure 4.15 Re-position for central receiver .....</b>	<b>74</b>

## **LIST OF ABBREVIATIONS**

ABS - Antilock Braking System

ATIS - Automatic Tyre Inflation Systems

CAN - Controller Area Network

CTIS - Central Tyre Inflation Systems

DC - Direct Current

DSSS - Direct Sequence Spread Spectrum

FHSS - Frequency-Hopping Spread Spectrum

GUI - Graphical User Interface

HIL - Hardware-In-Loop

HR-WPAN - High-Rate Wireless Personal Area Network

IEEE - Institute of Electrical and Electronics Engineers

IMU - Inertia Measurement Unit

LCD - Liquid Crystal Display

LED - Light-Emitting Diode

LR-WPAN - Low-Rate Wireless Personal Area Network

MIROS - Malaysian Institute of Road Safety

NMVCCS - National Motor Vehicle Crash Causation Survey

OEM - Original Equipment Manufacturer

PWM - Pulse Width Modulation

RF - Radio Frequency

RSSI - Received Signal Strength Index

TPMS - Tyre Pressure Monitoring System

UDMS - Universal Data Monitoring System

USM – Universiti Sains Malaysia

WLAN - Wireless Local Area Network

# PEMODELAN TENTANG KELAKUAN PUTARAN TAYAR MELALUI SISTEM PENGAWASAN TEKANAN TAYAR

## ABSTRAK

Peningkatan bilangan kenderaan bermotor yang pesat di negara-negara berorientasikan teknologi telah membawa kepada peningkatan yang drastik dalam kemalangan jalan raya disebabkan oleh beberapa faktor. Faktor-faktor ini boleh dikategorikan kepada tiga faktor utama iaitu keadaan persekitaran jalan raya, tingkah laku manusia, dan masalah kenderaan. Di antara ketiga-tiga faktor, masalah kenderaan merupakan satu-satunya parameter yang boleh dimanipulasi apabila dibandingkan. Berdasarkan statistik, kajian mendapati keadaan tayar dan roda motosikal adalah punca utama yang menyumbang kepada kemalangan maut jalan raya. Oleh itu, adalah perlu untuk membina sistem yang dapat memantau keadaan tayar motosikal di jalan raya. Walaupun terdapat beberapa sistem pemantauan yang sedia ada, tetapi setiap sistem mempunyai kelebihan dan kekurangan tersendiri dalam kekangan aplikasi. Sebagai contoh, parameter utama seperti bacaan tekanan pneumatik dari tayar motosikal tidak dikemaskini secara langsung, hal ini boleh menyebabkan keadaan menjadi lebih teruk apabila berlaku kebocoran pada tayar. Selain itu, keadaan putaran roda seperti kenaikan dan penurunan pecutan serta kecekapan cengkaman brek yang tidak diambil kira boleh menjurus kepada penghasilan haba, terutamanya di negara-negara yang berada di garisan Khatulistiwa yang mempunyai jalan raya yang panas sepanjang siang hari. Di samping itu, penempatan pemancar dan penerima bagi tujuan komunikasi tanpa wayar perlu diperbaiki untuk memastikan kualiti penghantaran maklumat dapat dilaksanakan dengan baik, tindakan ini bertujuan untuk mengelak transmisi maklumat yang salah atau tertangguh. Objektif kajian ini adalah untuk membangunkan satu sistem pemantauan yang menggabungkan kelebihan sistem pengukuran secara langsung dan tidak langsung dalam usaha untuk mengatasi masalah seperti yang dibincangkan. Sistem ini perlu memantau bacaan tekanan tayar yang dikemas kini secara langsung dan membuat kiraan jumlah jarak perjalanan menggunakan algoritma berdasarkan kajian keadaan putaran roda kenderaan tersebut. Selain itu, parameter tahap kuasa telah dikaji melalui penunjuk kekuatan penerimaan isyarat untuk tujuan pemantauan kualiti transmisi. Sistem ini mempunyai dua bahagian iaitu modul pemancar dan modul penerima. Modul pemancar dibina daripada kombinasi perkakasan seperti pengawal mikro modul *bluetooth* dan peranti pengesan yang terletak pada rim tayar untuk memperolehi status keadaan tayar. Manakala modul penerima berfungsi sebagai pengumpul dan penganalisa maklumat yang diterima dari modul pemancar dan memberi maklum balas apabila status keadaan tayar tidak normal. Hasil keputusan daripada beberapa eksperimen yang telah dijalankan menunjukkan bahawa penempatan pemancar dapat memastikan bacaan penunjuk kekuatan penerimaan isyarat yang konsisten iaitu pada -70 dBm dengan kelajuan putaran tayar yang berbeza dan kedudukan pemancar yang berbeza dari jarak yang sama. Hasil kajian juga menunjukkan bahawa prestasi putaran roda dapat dikenal pasti dan menghasilkan anggaran jarak yang dilalui kenderaan berdasarkan kiraan jumlah jarak perjalanan. Selain itu, tahap tekanan pneumatik tayar telah dirumus dan ketepatan hasilnya telah dipastikan dengan kaedah kejuruteraan balikan sebanyak  $\pm 20$  kPa daripada nilai toleransi projek. Secara keseluruhan, penyelidikan ini telah berjaya memperoleh bacaan tahap tekanan secara langsung daripada roda yang berputar, membuat kiraan jumlah jarak yang dilalui berdasarkan kitaran putaran roda dan menempatkan pemancar dan penerima berdasarkan parameter tahap kuasa untuk memastikan kualiti transmisi.

# **THE MODELLING OF TYRE ROTATION BEHAVIOUR WITH TYRE PRESSURE MONITORING SYSTEM**

## **ABSTRACT**

The number of motorized vehicles is rapidly increasing in the technology driven countries, and led to the dramatic increase in road accident. The causes of accidents can be categorized into three major factors which are road environmental condition, human behaviour, and vehicle defects. The vehicle defects are the only parameter that is controllable when compared with to other two factors. Statistics show that the tyre and wheels-related from motorcycles is the critical reason and major contributor to road death accident. Therefore, there is the necessity to build a system that is able to monitor the on-road tyre condition. Several existing monitoring systems are available, but each has its own advantages and disadvantages based on the application's limitation. For example, the important parameter such as pneumatic pressure captured from the tyre is not in real-time, thus it may become worst when there is air leakage. Besides that, tyre rotation behaviour such as acceleration, deceleration and sharp brake condition is not considered which may tend to build up heat. Especially in the countries on the equator which have warm road pavement throughout the daytime. In addition, the placement of transceiver for wireless communication need to determine in order to avoid misinterpretation on the wrong/delayed result captured. The research objective is to develop a monitoring system that combines the advantages of direct and indirect measurement system in order to overcome the problem as discussed. The system needs to capture the real-time pressure level on running tyre and provide calculations on the total distance travelled by the vehicle through algorithms from investigation of tyre rotation behaviour. Apart from that, the power level parameter was studied through the received signal strength index (RSSI) calibration for transmission quality purposes. The system consist of two parts which are the transmitter module and receiver module. The transmitter module is built from combination of hardware such as microcontroller, bluetooth module and sensing devices which sat on the tyre rim to acquire tyre condition. Whereas, the receiver module is responsible to collect and analyze information from the transmitter module and provide a feedback whenever an abnormal tyre condition occurred. Several experiments were conducted, the result shows that the placement of transceiver can be justified with consistent RSSI at -70 dBm from different tyre rotation speed and different transmitter's directions with the same displacement. The result also shows that the performance of tyre rotation behaviour is able to identify and provide the estimation of distance travelled by the vehicle with evidence support from distance travel calculation. Lastly, the pneumatic pressure level inside the tyre was captured and the result accuracy is further ensured with reversed engineering method with  $\pm 20$  kpa from project tolerance. Overall, the research work is able to capture the real-time pressure level on running tyre, provide calculation on total distance travelled based on tyre rotation cycle and position the transceiver based on the power level parameter to ensure the transmission quality.

# CHAPTER 1

## INTRODUCTION

### 1.1 Background

In a technology driven century, the number of road accident is dramatically increase due to the rapid rising of motorized vehicles on the road as tabulated in the statistics of General Road Accident Data in Malaysia [1]. Table 1.1 clearly stated the trend of road crashes for 20 years until 2016. The number of road crashes in the year 2015 is nearly multiple with a factor of 1.5 which equal to 161,000 cases when compared to the year 2005. In addition, road deaths are weighted 6706 of cases from the road crashes, this remains highly unacceptable which results in very high economic and social costs to the nation.

**Table 1.1 Statistic of General Road Accident Data in Malaysia [1]**

Year	Registered Vehicles	Population	Road Crashes	Road Deaths	Serious Injury	Slight Injury	Index per 10,000 Vehicles	Index per 100,000 Population	Indeks per billion VKT
1997	8,550,469.00	21,665,600.00	215,632.00	6,302.00	14,105.00	36,167.00	7.37	29.10	33.57
1998	9,141,357.00	22,179,500.00	211,037.00	5,740.00	12,068.00	37,896.00	6.28	25.80	28.75
1999	9,929,951.00	22,711,900.00	223,166.00	5,794.00	10,366.00	36,777.00	5.83	25.50	26.79
2000	10,598,804.00	23,263,600.00	250,429.00	6,035.00	9,790.00	34,375.00	5.69	26.00	26.25
2001	11,302,545.00	23,795,300.00	265,175.00	5,849.00	8,680.00	35,944.00	5.17	25.10	23.93
2002	12,068,144.00	24,526,500.00	279,711.00	5,891.00	8,425.00	35,236.00	4.90	25.30	22.71
2003	12,819,248.00	25,048,300.00	298,653.00	6,286.00	9,040.00	37,415.00	4.90	25.10	22.77
2004	13,828,889.00	25,580,000.00	326,815.00	6,228.00	9,218.00	38,645.00	4.52	24.30	21.10
2005	15,026,660.00	26,130,000.00	328,264.00	6,200.00	9,395.00	31,417.00	4.18	23.70	19.58
2006	15,790,732.00	26,640,000.00	341,252.00	6,287.00	9,253.00	19,885.00	3.98	23.60	18.69
2007	16,813,943.00	27,170,000.00	363,319.00	6,282.00	9,273.00	18,444.00	3.74	23.10	17.60
2008	17,971,907.00	27,730,000.00	373,071.00	6,527.00	8,868.00	16,879.00	3.63	23.50	17.65
2009	19,016,782.00	28,310,000.00	397,330.00	6,745.00	8,849.00	15,823.00	3.55	23.80	17.27
2010	20,188,565.00	28,910,000.00	414,421.00	6,872.00	7,781.00	13,616.00	3.40	23.80	16.21
2011	21,401,269.00	29,000,000.00	449,040.00	6,877.00	6,328.00	12,365.00	3.21	23.70	14.68
2012	22,702,221.00	29,300,000.00	462,423.00	6,917.00	5,868.00	11,654.00	3.05	23.60	13.35
2013	23,819,256.00	29,947,600.00	477,204.00	6,915.00	4,597.00	8,388.00	2.90	23.10	12.19
2014	25,101,192.00	30,300,000.00	476,196.00	6,674.00	4,432.00	8,598.00	2.66	22.00	10.64
2015	26,301,952	31,190,000	489,606	6,706	4,120	7,432	2.55	21.5	9.6
2016	27,613,120	31,660,000 <sup>e</sup>	521466 <sup>a</sup>	7152 <sup>a</sup>	TBP	TBP	2.59	22.6	10.7 <sup>a</sup>

e = Estimated value from Department of Statistics Malaysia  
a = Media statement  
NA = Not available (The official figures are not available yet )  
TBP = To be published

According to the Malaysian Institute of Road Safety Research (MIROS) report, there are three major factors that contribute to road accidents, such as human factor, road environmental condition, and vehicle defects [2]. The vehicle defect contributed 6.2% from the factor, which is at huge amount of cases when converted into numerical value, 30,335 cases to be exact.

In order to root cause this issue, road deaths can be categorized by the type of vehicle involved as shown in Table 1.2. Motorcycles and motorcars are the major contributors in road death which weighted 83.5% among the road death crashes [2].

**Table 1.2 Statistic of Road Deaths by Type of Vehicle [2]**

Types of Vehicle	The Number of Deaths
Motorcycle	4485
Motorcar	1489
Pedestrian	511
Lorry	186
4 Wheel Drive	142
Others	122
Bicycle	123
Van	65
Bus	29
Total	7152

Besides that, vehicle defect is the only parameter that is able to be controlled and prevented before an accident happens when compared to the other two major factors. The vehicle defect can be further attribute into several critical reasons. From the publication of The National Motor Vehicle Crash Causation Survey (NMVCCS), the vehicle related critical reasons were mainly measured through external inspection of the vehicle components such as tyres, brakes, and steering as shown in Table 1.3. The table shows that the tyre/wheels-related components are the known reason which contributed the highest number of cases, weighted 35% from the vehicle defect factor [3].

**Table 1.3 Vehicle Related Critical Reasons [3]**

Critical Reason	Estimated (Based on 2% of the NMVCCS crashes)	
	Number	Percentage* ± 95% conf. limits
Tires /wheels-related	15,000	35% ± 11.4%
Brakes-related	10,000	22% ± 15.4%
Steering/suspension/transmission/ engine-related	2,000	3% ± 3.3%
Other/unknown vehicle-related problems	17,000	40% ± 24.0%
Total	44,000	100%

Based on the comparisons of statistical result, it is concluded that the major contributor to the number of accidents is the vehicle defects from motorcycle with tyre/wheels related issues. Therefore, there is a need to develop a reliable tyre pressure monitoring system that considers tyre rotation behaviour such as acceleration, deceleration and sharp brake condition, in order to reduce the number of accidents.

## **1.2 Problem Statements**

The main purpose of the investigation of tyre rotation behaviour through modelling algorithm with tyre pressure monitoring system is to reduce the number of accidents in term of tyre related defects. In addition, the proposed algorithm for tyre rotation cycles can be utilized for developing driverless vehicle or smart car systems. There are several types of tyre monitoring system available and it can be categorized into two systems which is direct measurement and indirect measurement. In short, the direct measurement system measures the tyre pressure through sensing device, whereas indirect measurement system measures the other parameters other than tyre pressure. Both direct and indirect measurement has advantages and disadvantages based on working principle.

Existing monitoring systems are unable to show the real-time pneumatic pressure level inside the tyre when the vehicle is running and this may become worse whenever any air is leaking. The real-time system was proposed with the advanced integration techniques applied to provide real-time

tyre pressure monitoring [4]. Although the real-time reading can be obtained via integration techniques, it's only applicable to stationary vehicle wheels. None of the experiment is discussed during their rotation. Apart from that, the pneumatic pressure level inside the tyre will increase with respect to distance travelled due to several rotational behaviour such as acceleration and sharp braking which may lead to the buildup of heat, especially under hot ambient temperature.

Several great publications focused on enhancing the monitoring system either through hardware and software. There are hardware minimization through specific antenna design [5] and power recovery circuit with battery-less [6] while there are also software based implementations such as off-road simulation and graphic user interface [7]. However, none of these topics survey the placement and positioning of the transceiver. This is the important factor that may affect the data transmission quality and lead to misinterpretation on the captured result.

### **1.3 Research Objectives**

The research objectives

- i. To develop a monitoring system with the advantages of indirect measurement system, which provide calculation on total distance travelled by the vehicle.
- ii. To develop a monitoring system with the advantages of direct measurement system, which able to capture the real-time pressure level on running tyre.
- iii. To determine the placement of the transmitters and receiver based on power level parameter through the received signal strength index (RSSI) calibration to ensure the transmission quality.

### **1.4 Research Scope**

From the statistical survey discussed in the previous section, vehicle defects of motorcycles related to tyre/wheels is the major contributor to the road death accidents, hence this research is aimed to provide the monitoring system based on the tyre condition. This monitoring system will focus on motorcycles tyre which is the highest number of vehicle from crash report cases [3]. The literature

review on the type of tyre will be discussed, only the tubeless radial tyre will be applied to the research work because of the tyre construction was suitable to be used in experiment while the other type of tyre is not considered. The tyre model for this research is fixed with 80/90-17 M/C 44P. Besides, gauge pressure is used in several algorithm calculations instead of absolute pressure because the experiment was not test in a vacuum environment. The research system monitored on the parameters such as pneumatic pressure inside the tyre, tyre temperature and wireless coverage throughout several experiments. From the experiment, pneumatic pressure will be monitored at range from 180 kPa to 270 kPa with 20 kPa of tolerance and resolution, and temperature at 20 to 65 degree Celsius with reference to the weather range of Malaysia [8] and project coverage range with 0.1 degree Celsius of resolution. The Bluetooth coverage ranges is from 0 to 4 meters, which covers the motorcycle size. All the experiments will take place in standard road conditions with dry and flat surface (tar road) and altitude of 60 meters as the guidance in order to achieve the stated objectives with consistent results.

With literature surveyed and fixed project specification, this research will able to investigate the tyre rotation behaviour through modelling algorithm with the proposed system (direct and indirect measurement), which is small in size and able to function well inside the tyre. This research will use motorcycle (2-wheel vehicle) to develop the stated objectives such as the real-time pressure level, the total distance traveled algorithm and the placement for transceiver with multiple sensors (accelerometer, pressure sensor, and thermometer) mounted inside the tyre. The monitoring system is able to show the real time tyre condition in term of pneumatic pressure and temperature parameters and provide feedback system through display, light indicator and alarm when the tyre runs under abnormal condition.

### **1.5 Research Contribution**

This research contributes to provide alternative distance traveled calculation based on the proposed algorithm through developing the tyre pressure monitoring system. The system was enhanced from only measure of pneumatic pressure to tyre rotation behaviour such as acceleration, deceleration and sharp braking condition. Apart from that, the placement for the transceiver is relocated with the determination of RSSI to ensure the transmission quality.

## **1.6 Thesis Outline**

In chapter 2, the results of comprehensive literature review is deliberated with more in-depth counterpart of the literature review in chapter 1. The overview of various segments such as existing tyre pressure monitoring system, tyre construction and inflation is discussed. The paper review on several techniques comparison for tyre rotation behavior, wireless technologies applications, and the relationship between pneumatic pressure level and tyre performance is conducted.

In chapter 3, the methodology of the research is charted on how the research objective can be achieved. The five development stages of this research work will be discussed. The system flow of sensing module is presented in terms of a flow chart in the first stage, continued with comparison and selection of hardware, software and sensing device. The third stage is the proposed system circuit design and implementation on motorcycle rim. Next, the experimental setup for each experiment is discussed in detail with specific situations and theories involved.

In chapter 4, the discussions and findings from each experiment will be conducted in this chapter. The result obtained from the system is presented in the form of a table or graph and followed by discussion on findings supported by theory, and analysis of the findings is done to determine whether the findings align with the experiment hypothesis assumption or vice versa contradict to the expected result.

In chapter 5, the nutshell of research work which summarizes and explains the aims, important findings and conclusion. The evaluation of modelling algorithm with commentary on the contribution and limitations of the research work was discussed. Lastly, recommendations for further improvement areas that are needed to enhance the performance and accuracy of the system is discussed.

## **CHAPTER 2**

### **LITERATURE REVIEW**

#### **2.1 Introduction**

The overview of existing tyre pressure technologies was discussed in terms of the advantages and disadvantages based on application. The tyre construction and inflation conditions such as over inflation and under inflation is deliberated. This literature review is necessary before developing the system due to its specific application, for example, existing tyre technologies Central Tyre Inflation Systems (CTIS) are only suitable for bus/truck tyres due to the operation principle. Several proposed techniques from the paper had been reviewed to make comparisons and areas that needed improvements were identified. The review on tyre rotation behavior, wireless technology applications, and the relationship between pneumatic pressure level and tyre performance is conducted.

#### **2.2 Existing Tyre Monitoring Technologies**

##### **2.2.1 Direct and Indirect Measurements**

The tyre monitoring system is developed to acquire pneumatic pressure level reading inside the tyre for specific vehicle based on several technologies. These monitoring system was classified into two major categories such as direct and indirect measurement [10]. The direct and indirect measurement have different operation principle, but both measurements are able to provide feedback when the tyre runs under abnormal pressure condition. The direct systems will attach a sensing devices and a transmitter inside the tyre as illustrated in Figure 2.1 and transmit the information wirelessly to the receiver. The information was analyzed by the system and warns the driver if the tyre pressure is below or above predetermined level. The direct systems are able to detect pressure levels as small as one PSI (pounds per square inch) in term of resolution. Whereas,

the indirect systems have an alternative way in monitoring the tyre instead of checking the pneumatic pressure level. This system monitors the rate of revolution from each wheel. For example, as shown in Figure 2.2 the tyre that has lower pressure will roll at a different revolution per distance as compared to other tyres. The system will feedback the abnormal tyre condition to the driver without generating the accurate pressure reading. The limitation of this system occurred when all the tyres runs under abnormal conditions and will result in misinterpretation of information [11].

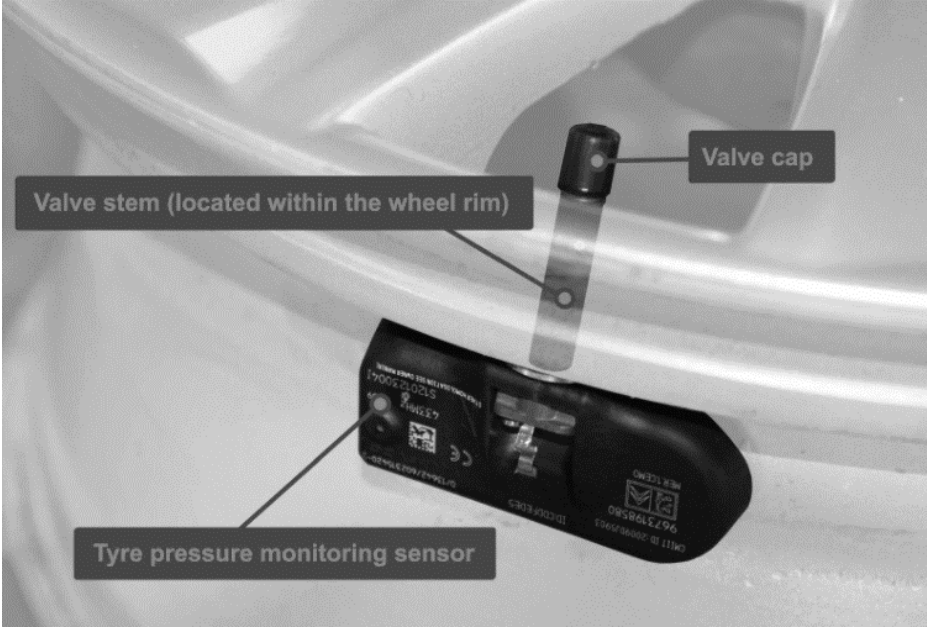

**Figure 2.1 Sensor Placement for Direct System [9]**



**Figure 2.2 Operation Principle for Indirect System [12]**

### 2.2.2 Survey and Comparison of Tyre Monitoring Technologies

According to the survey conducted, there are five different types of monitoring approaches available with current technology. The available approaches are Tyre Pressure Monitoring System (TPMS), Central Tyre Inflation Systems (CTIS), Automatic Tyre Inflation Systems (ATIS), Dual Tyre Pressure Equalizers and Passive Pressure Containment Approaches as shown in Figure 2.3. Each technology addresses specific vehicle inflation problem. The comparison and description of the working principle of each technology was discussed in Table 2.1.

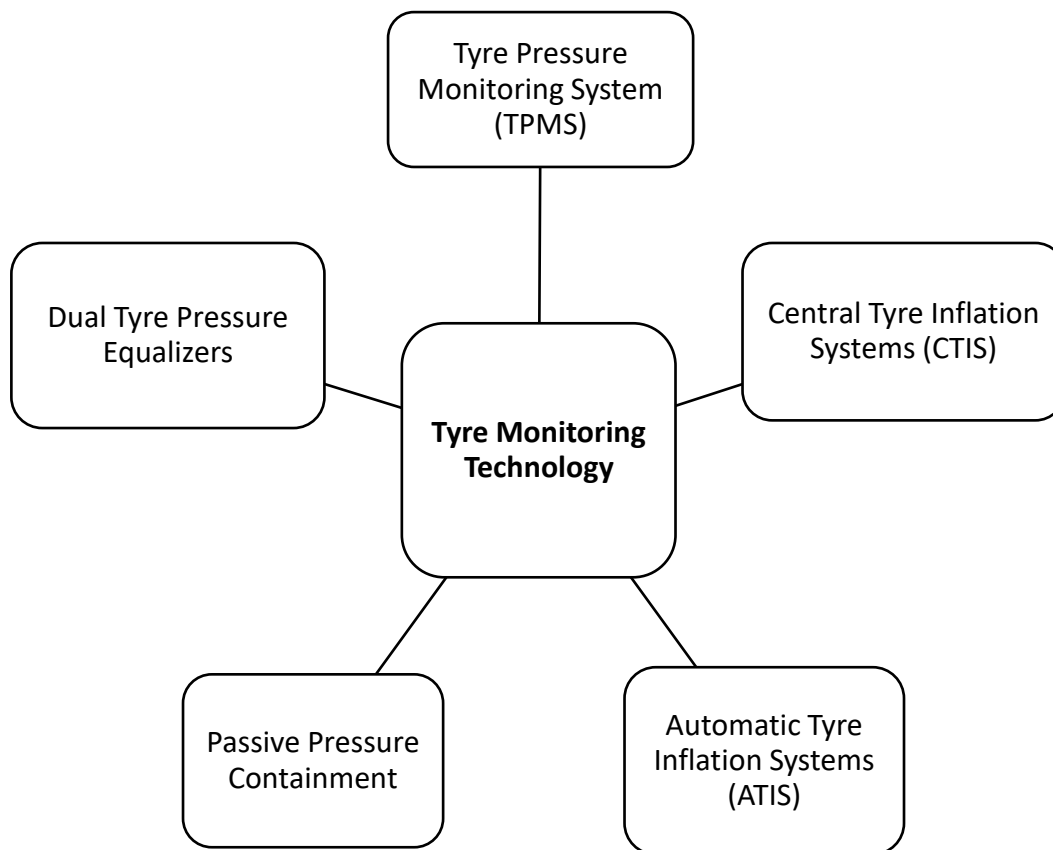

**Figure 2.3 Tyre Monitoring Technology Categories**

**Table 2.1 The Comparison of Tyre Monitoring Technologies Working Principle [13, 14]**

Pros	Cons
Tyre Pressure Monitoring System (TPMS) - Working Principle: Direct measure pressure level and compared with pre-set value.	
<ul style="list-style-type: none"> <li>i. Direct measurement system</li> <li>ii. Feedback system provided</li> </ul>	<ul style="list-style-type: none"> <li>i. Sensing device attached to fragile valve</li> <li>ii. Pre-installation necessary and the system is not standardized</li> </ul>
Central Tyre Inflation Systems (CTIS) - Working Principle: User owns the control and able to select the target pressure level in order to adjust the pressure level for specific operation	
<ul style="list-style-type: none"> <li>i. Reduce the vibration and shock loading</li> <li>ii. Possible of flexible control</li> </ul>	<ul style="list-style-type: none"> <li>i. Not able to show the actual pressure level</li> <li>ii. Only used for off-road transport vehicle</li> </ul>
Automatic Tyre Inflation Systems (ATIS) - Working Principle: Monitor tyre inflation level with a pre-set value and inflate/relief whenever the tyre is underinflated/overinflated.	
<ul style="list-style-type: none"> <li>i. Automatically re-inflate tyre to pre-set pressure level</li> <li>ii. Able to relieve pressure when over-inflated</li> </ul>	<ul style="list-style-type: none"> <li>i. Not able to show the actual pressure level</li> <li>ii. Rely on compressed-air tanks as inflation source which occupied space</li> </ul>
Dual Tyre Pressure Equalizers - Working Principle: Attempt to bring the same pressure level inside the tyre when facing any unequal loading, temperature, and slow air seepage.	
<ul style="list-style-type: none"> <li>i. The track is leaking with visual display</li> <li>ii. Balancing for both tyre pressure levels</li> </ul>	<ul style="list-style-type: none"> <li>i. Only used for truck or vehicle with dual tyres</li> <li>ii. Sensor mounted on hose connection between each tyre valve stem</li> </ul>
Passive Pressure Containment Approaches - Working Principle: Another medium inserted into the tyre and capable of maintaining the pressure level once inflated.	
<ul style="list-style-type: none"> <li>i. Able to reduce natural air loss with lower permeation rate</li> <li>ii. Provide barriers to air loss</li> </ul>	<ul style="list-style-type: none"> <li>i. Can mitigate the effect of punctures</li> </ul>

## 2.3 Type of Tyre Construction, Improper Inflations and Tyre Depth Measurement

### 2.3.1 Bias-ply and Radial Tyre Construction

This section discussed the performance and differences between bias-ply and radial tyre construction, while other types of tyre were excluded such as summer tyre, winter tyre, and wet weather tyre. The construction method of bias-ply was shown in Figure 2.4 while radial was shown in Figure 2.5. Bias-ply versus radial tyre was tabulated in Table 2.2 in term of differences, contact to ground, temperature and cornering.

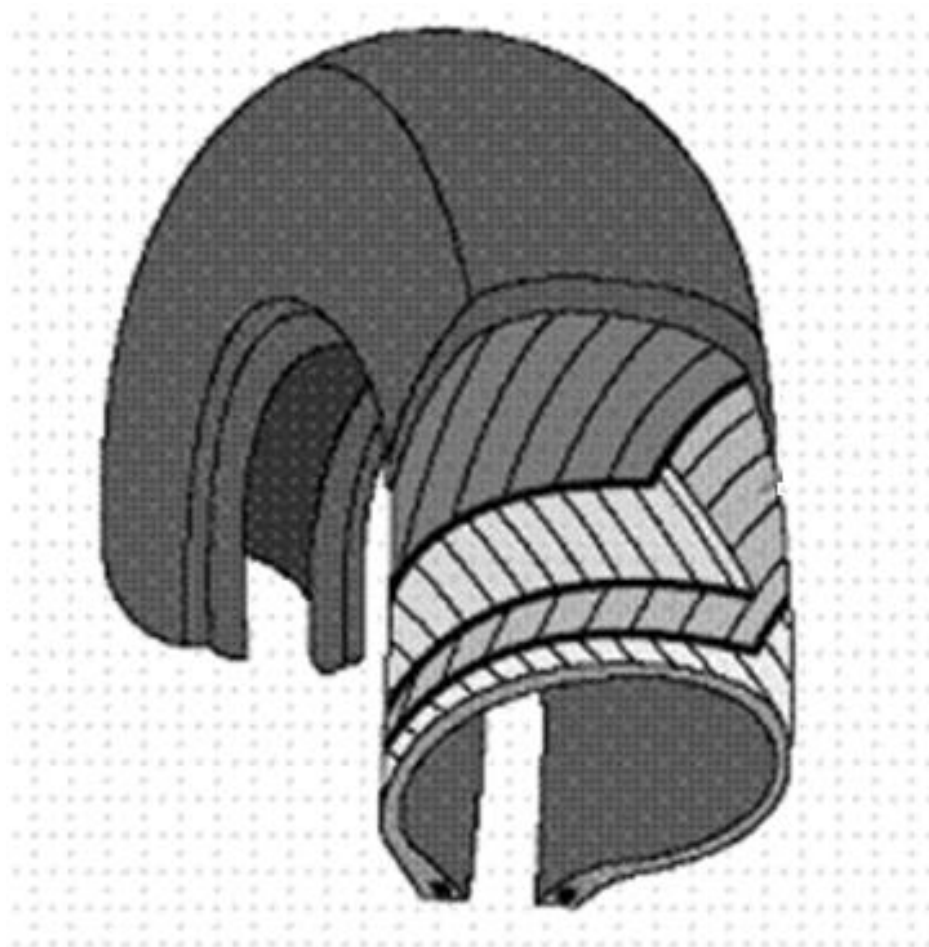

**Figure 2.4 Bias-ply construction [15]**

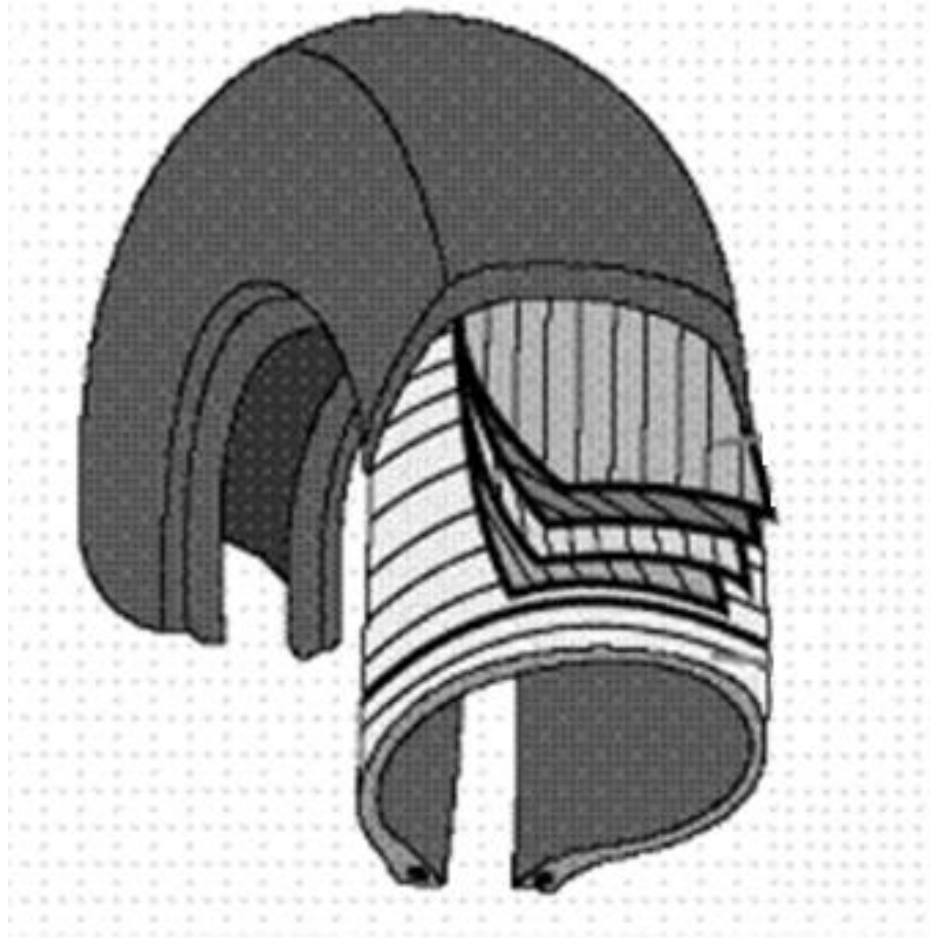
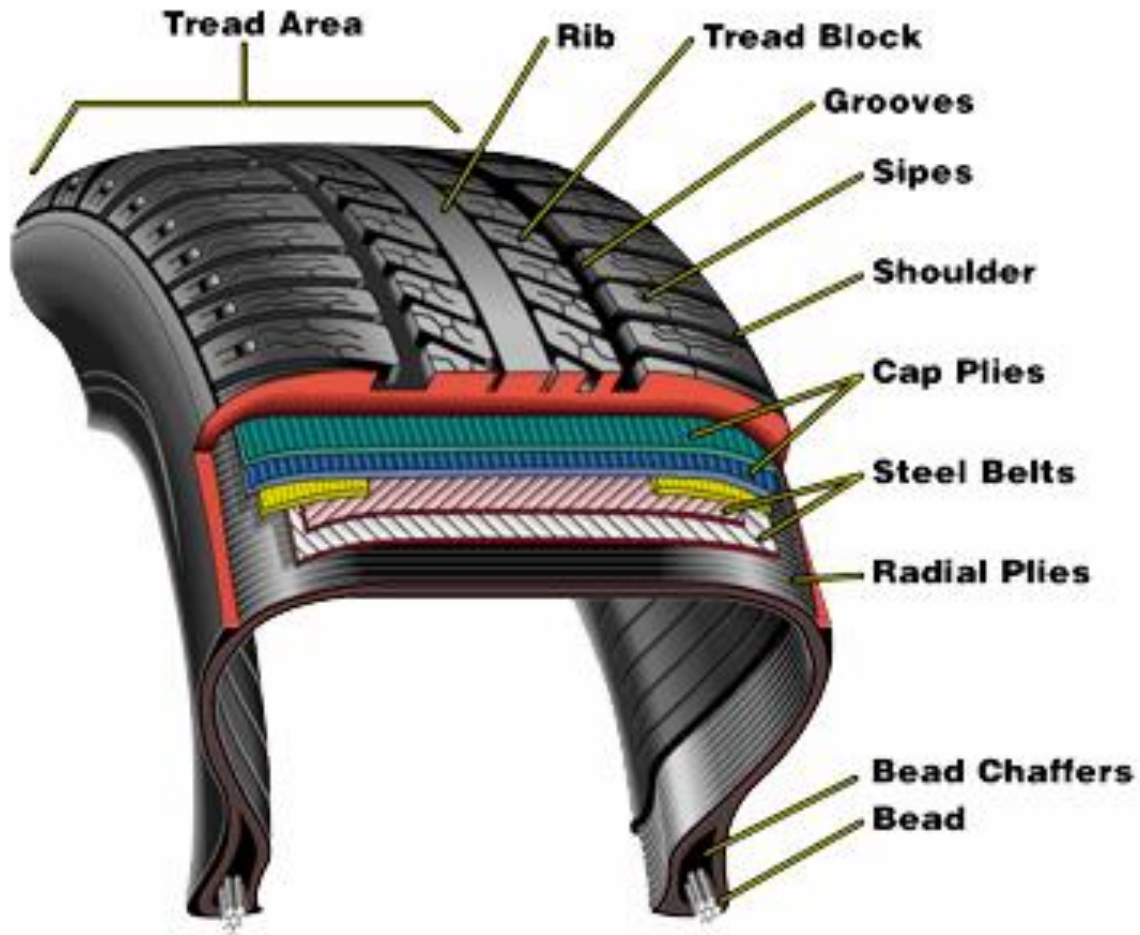

**Figure 2.5 Radial construction [15]**

Radial tyre is better compared to bias-ply tyre as it eliminated the unnecessary characteristic from bias-ply tyre. The radial tyre having lesser layers of body cord on its sidewall allows better flexibility. The thread can have a full contact area with the ground when experiencing cornering or heavy load. The bias-ply design is more independent as the sidewall and thread works separately with better than bias-ply permits. Therefore, the research work will only focus on the radial construction tyre shown in Figure 2.6.

**Table 2.2 Performance and Differences of Bias-ply and Radial Technologies [15]**

Bias-ply	Radial
Construction Method	
Bias-ply tyres in constructed into a single unit by layers of rubber coated with plies of about 30 degree angle of the diagonal.	Radial tyre constructed of 2 parts which is one layer of rubber-coated with steel cables and the arc bead to bead with 90 degree angle.
Pros and Cons from the construction	
<ul style="list-style-type: none"> <li>i. Tyre thread will distort when experiencing heavy load due to the deflection of sidewall. These will reduce the tyre life as decreasing the traction.</li> <li>ii. The performance of cornering is weaker when compared to radial due to the strength of tyre sidewall.</li> <li>iii. Increasing the layer of plies and bead cable wire able enhanced the strengthen hence reduce in chances of puncture</li> <li>iv. The drawbacks when the plies layer increase is the built up heat due to the increase of mass, therefore resulting in reduce tyre life.</li> </ul>	<ul style="list-style-type: none"> <li>i. Less distortion of tyre thread as the tyre sidewall is flexible even when heavy load applied. Tyre resistance to puncture is increasing with the vertical deflection.</li> <li>ii. More stable and balance when the tyre is cornering because the sidewall and thread able to maintain the tread flat.</li> <li>iii. Increasing the diameter of steel cable used which preventing the tyre from puncture and provide a cooling mechanism as steel cable distribute heat faster.</li> <li>iv. The drawback when applying larger diameter cable resulting in higher petrol consumption due the heavy weight.</li> </ul>



**Figure 2.6 Description of radial tyre components [16]**

### **2.3.2 Tyre Failure Caused by Improper Inflation**

Based on the survey done in chapter 1, the major contributor of accidents is tyre/wheel related issues from vehicle defect. This section will cover the critical defect of tyre failure caused by improper inflation. Tyre inflation failures can be categorized into 3 parts which consist of over-inflation, under-inflation and tyre wear [17].

Tyre over-inflation can be defined as when the tyre experiences excessive pneumatic pressure. Due to the ride harshness was increased, the overinflating of tyres will result in serious tyre damage caused by any potholes or small sharp objects on the road. The tyre comes into contact with the ground at only the center portion. The small contact area increases the rate of wear and tear at tread

center and becomes more susceptible to any impact damage as illustrated in Figure 2.7. On the contrary, tyre under-inflation means the pneumatic pressure level inside the tyre is much lower than original equipment manufacturer (OEM) recommended operating inflation conditions. Under-inflated tyres when run with serious high temperature may lead to sudden blowout, especially during high revolution when a tyre is under inflated. Under inflation normally is due to a lack of frequent maintenance and slow air leakage from the tyre. Under inflation will result in excessive flexing of the sidewall, rapid wear of the tread shoulders, and high fuel consumption due to excessive friction between the tyre and ground surface as illustrated in Figure 2.7.

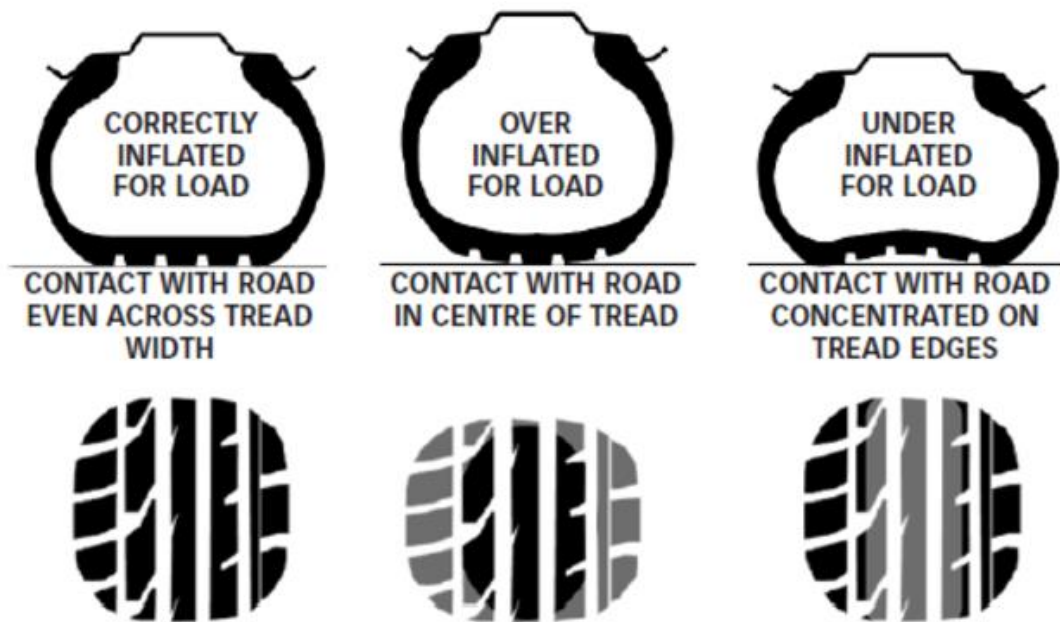

**Figure 2.7 Tyre Failures Caused by Improper Inflation [18]**

Frequent use of the vehicle or speeding may result in tyre being worn out Tyre wear means the reducing of tyre thread until it is lower than the acceptable tread depth which is 1.6mm [19]. Every tyre has the average life of about 30,000 to 60,000 km based on the various sizes and kinds of vehicle [20]. Through the accumulated mileage traveled by the tyre, the wear bars inside the tread grooves are seen which indicates wear condition as shown in Figure 2.8. The tyre is considered worn out when wear bars are flushed with the tyre tread. The other method of tyre wear

measurement can be done by inserting the pinhead of tread depth gauge, which is the common and most accurate among the other measurement such as Penny Test and 20p Test [21].



**Figure 2.8 Wear Bar inside the Tyre Thread [22]**

## **2.4 Wireless Technologies**

### **2.4.1 Overview of Technologies Survey in Wireless Communication for Vehicle**

Wireless communication is the transfer of information or power between two or more points that are not physically connected. For TPMS, the transmission is done by a single or multiple transmitter(s), Tx and receiver, Rx. The wireless technologies were classified into a standard by the Institute of Electrical and Electronics Engineers (IEEE) such as IEEE 802.15.1, IEEE 802.15.3, IEEE 802.15.4, and WiFi.

IEEE 802.15.1 or known as Bluetooth uses the FHSS technique (Frequency-Hopping Spread Spectrum), which splits the frequency band of 2.402-2.480 GHz into 79 channels (called hops) with 1 MHz for each channel. The signal is transmitted using a sequence of channels known to both transmitter and receiver. Therefore, by switching channels Bluetooth standard can avoid interference with other radio signals [23].

IEEE 802.15.3 is designed to facilitate High-Rate Wireless Personal Area Network (HR-WPAN) for fixed, portable and moving devices, IEEE 802.15.4 addresses the needs of Low-Rate Wireless Personal Area Networks (LR-WPAN) which is designed to facilitate those wireless networks, which are mostly static, large, and consuming small bandwidth and power [24]. Both of these standards use Direct Sequence Spread Spectrum (DSSS), and it does not allow changes of operating channels once a connection is initiated [25].

Wireless Local Area Networks (WLANs) also known as WiFi is based on the IEEE 802.11 standards and depending on local authority restrictions IEEE 802.11 b/g/n supports up to 14 channels in the 2.4 GHz frequency range. WiFi is a well-established network, wide spread and used in various environments and devices. The wireless network operates with three essential elements that are radio signals, antenna and router. The radio waves are keys which make the Wi-Fi networking possible.

#### **2.4.2 Operation Mode**

Wireless network can be categorized into two modes of operations which is Ad Hoc and Infrastructured [26]. The network which does not rely on a preexisting infrastructure, for example the routers in wired networks or the managed access points are known as ad hoc. Whereas the Infrastructured operation mode requires a base station that act as a central node to connect the wireless terminals. The base station provides the features to enable access to other wireless networks or the internet or intranet and wireless terminals use the base station to relay their messages. There is a drawback of this mode of wireless network, the wireless terminals will fail to communicate when the center point malfunctions.

### 2.4.3 Frequency, Data Rate and Range

Radio frequency (RF) is the electrical oscillations in term of electromagnetic wave frequencies that lie in the range extending from around 3 kHz to 300 GHz [27], which include the frequencies used for communications or radar signals. The data transfer rate is affected by the selected frequency, whereas the power consumption is rely on range covered. The comparison of the Wireless network parameter is tabulated in Table 2.3.

**Table 2.3 Comparison of Wireless network parameters that used in In-vehicle transmission [24]**

Standard	Bluetooth	High rate WPAN	Low rate WPAN	WiFi
IEEE Spec.	IEEE 802.15.1	IEEE 802.15.3	IEEE 802.15.4	IEEE 802.11
Frequency band	2.4 GHz	2.4 GHz	868/915 MHz ; 2.4 GHz	2.4 GHz ; 5 GHz
Max. Data Rate	1 or 3 Mbps	11 – 55 Mbps	Depend on application	54 Mbps
App. Range	< 10 m	< 10 m	< 20 m	< 100 m
Power Level	1 mA - 60 mA	<80mA	20 $\mu$ A - 50 $\mu$ A	~ 116 mA
Issues				

### 2.4.4 Power Consumption

Power consumption of wireless technology is differentiated into 3 stages, such as transmit, receive and idle. The longer duration of wireless network is in idle the more efficient the power consumption. For TPMS where a battery source is the only the energy source to perform transmission, the power consumption of wireless technology must be taken as consideration. The energy consumption for several wireless protocols was tabulated in Table 2.4.

**Table 2.4 Energy Consumption of several wireless standard in different stages [26]**

Protocol	Energy Consumption		
	Sleep	Transmit	Receive
ZigBee	0.06 $\mu$ W	36.9 mW	34.8 mW
Bluetooth	330 $\mu$ W	215 mW	215 mW
WiFi	6600 $\mu$ W	835 mW	1550 mW

## **2.5 Review on Tyre Rotation Behaviour Model**

Tyre rotational behavior under different speeds in terms of revolution and different inflation condition will be conducted clearly in this section. The data transmission between transmitter and receiver will be investigated. All parameters such as revolution, inflation and data transmission needs to be considered because the result obtained from the experiment is fully controlled by these parameters. For example, the tyre running in acceleration will affect the reading of y axis from the inertial measurement unit.

### **2.5.1 Tyre Rotation under Different Revolution**

Tyre rotational behaviour can be categorized into 3 parts which are acceleration, deceleration and sharp braking condition. Dadashnialehi and his team published paper of Antilock Braking System (ABS) for In-Wheel Electric Vehicles using data fusion in 2013 [28]. The researchers improved the wheel speed measurement by the fusion concept with proposed novel architecture. ABS sensor is used in the measurement of wheel rotation speed by modulating the speed signal due to the frequency of the sensor which is influenced by the rotation speed. The concept of speed calculation is shown in Figure 2.9 with the reference clock applied, based on the angular velocity relationship to a radius of wheel and number of the gear teeth.

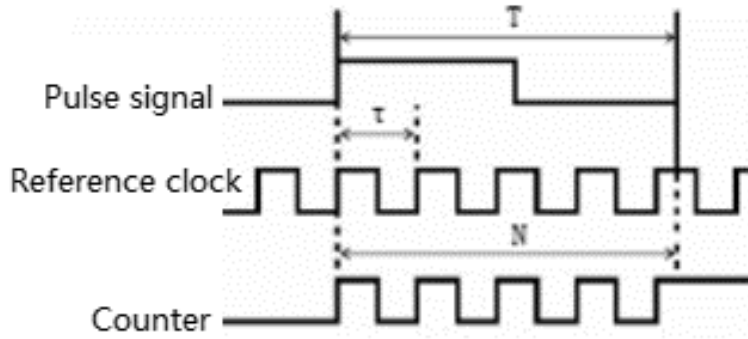

**Figure 2.9 Calculation of Wheel Speed [28]**

In the year 2015, Tannoury and his team introduced the variable structure observer for estimation of tyre rolling resistance and effective radius [29]. The paper proposed to consider the physical model of longitudinal dynamics and rotational speed of the wheel for wheel angular velocity and vehicle speed measurement. The test was carried out by the latter signal acquired from modern vehicle controller area networks (CAN). By the help of Newton's second law, the rotational speed can be traced for the forces acting on the wheel and the results show that the measured reading is aligned with the estimated speed as in Figure 2.10. This approach have the additional works that convert the force applied to the vehicle speed by applying Newton's law [30].

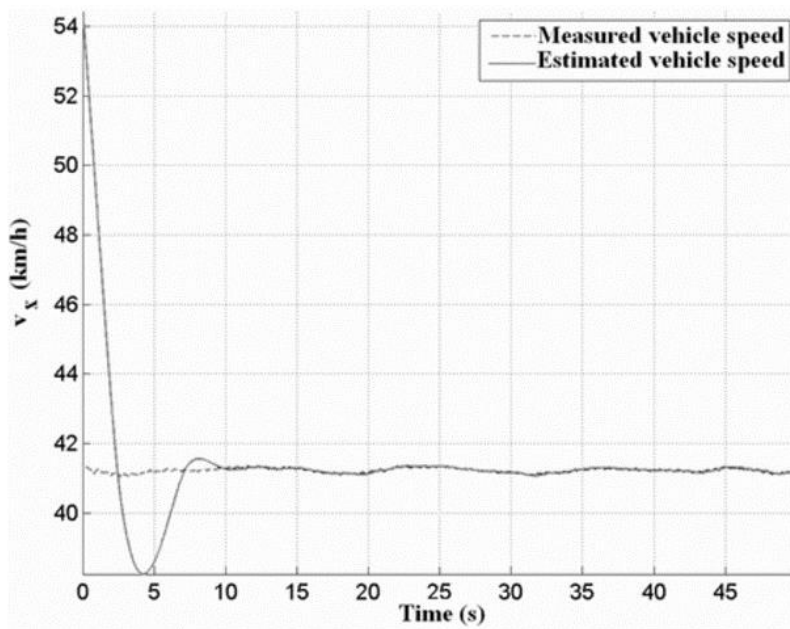

**Figure 2.10 Measured and estimated vehicle speed according to time [29]**

Bhuiyen and his partner introduced the low cost digital stroboscope for speed measurement. The measurement method for rotational speed of wheel is fully described [31]. The operating principle of the proposed strobe circuit will compare the reference frequency of oscillation and targeted rotational frequency. The reference and targeted frequency will have difference at first and the manually tune (from lowest to highest speed) the speed of reference oscillation frequency to synchronize with the targeted rotating substance frequency as shown in Figure 2.11. When the rotation speeds are parallel, the circuit will then capture and analyze the rotational speed by RPM formula. This proposed research work necessary to have the target rotating speed and take longer time on synchronization and speed measurement.

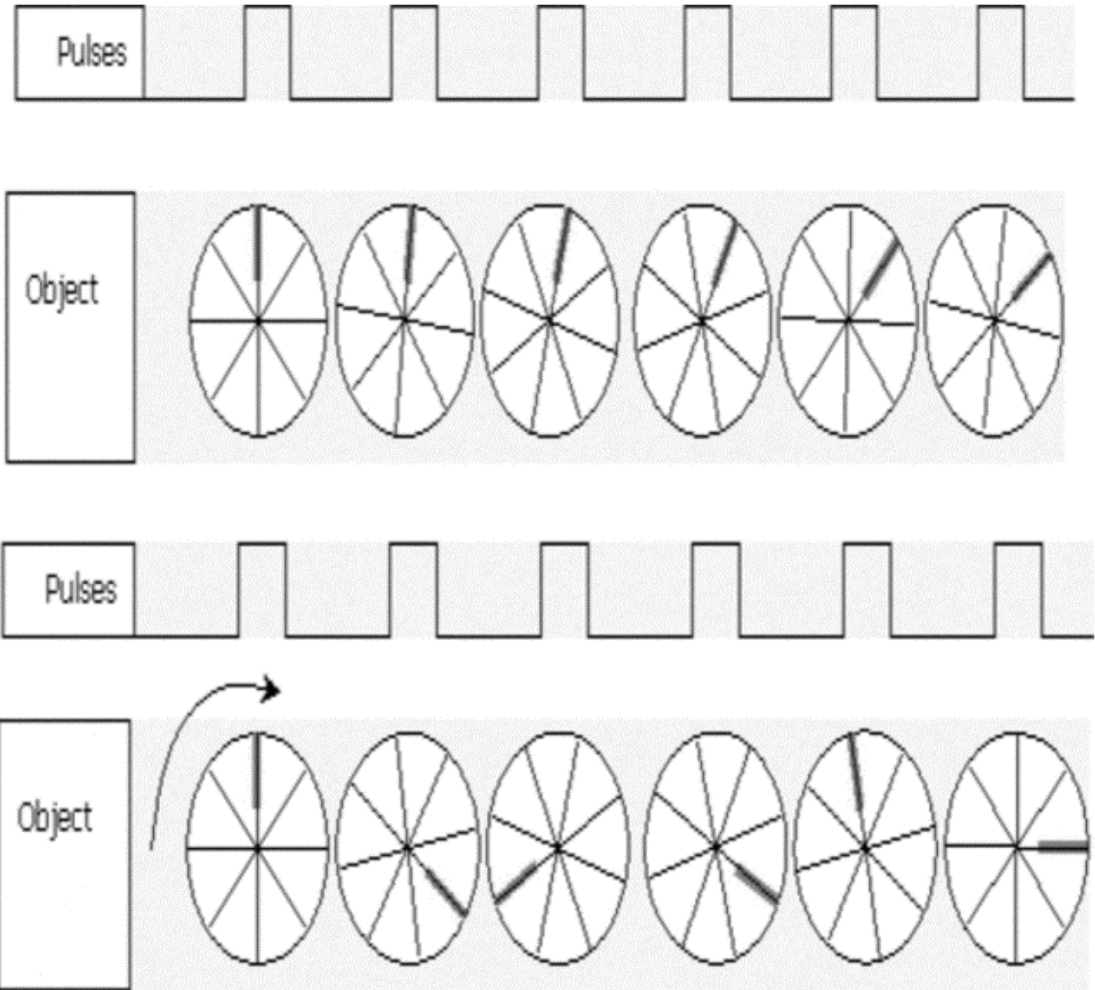

**Figure 2.11 Frequency of rotation compared to oscillation [31]**

## 2.5.2 Tyre Rotation under Different Inflation

Hendy and his team introduced the tyre pressure control system with LABVIEW program that is able to adjust and balance the pneumatic pressure level inside the tyres when different load is applied [32]. The adjustment of pressure range is between 1.15 bars to 2.25 bars (115 kPa to 225 kPa). The control algorithm is done by the 6-Rotary valve, the valve is used to inflate and deflate the air inside the tyre during rotation with the specific connection to the pressure line or atmosphere respectively. The net traction ratio (the act of pulling) against slip results in Figure 2.12 show that the tyre rotation behavior is directly influenced by the tyre inflation level. The tyre at high inflation level experienced less friction due to less tyre surface area contact to the ground and hence require low net traction. In addition, when heavier load is applied to the same inflation level tyre, the net traction significantly increases with respect to the same slip. The comparison of the tyre rotation behavior with a different inflation level is show in Figure 2.12 [32].

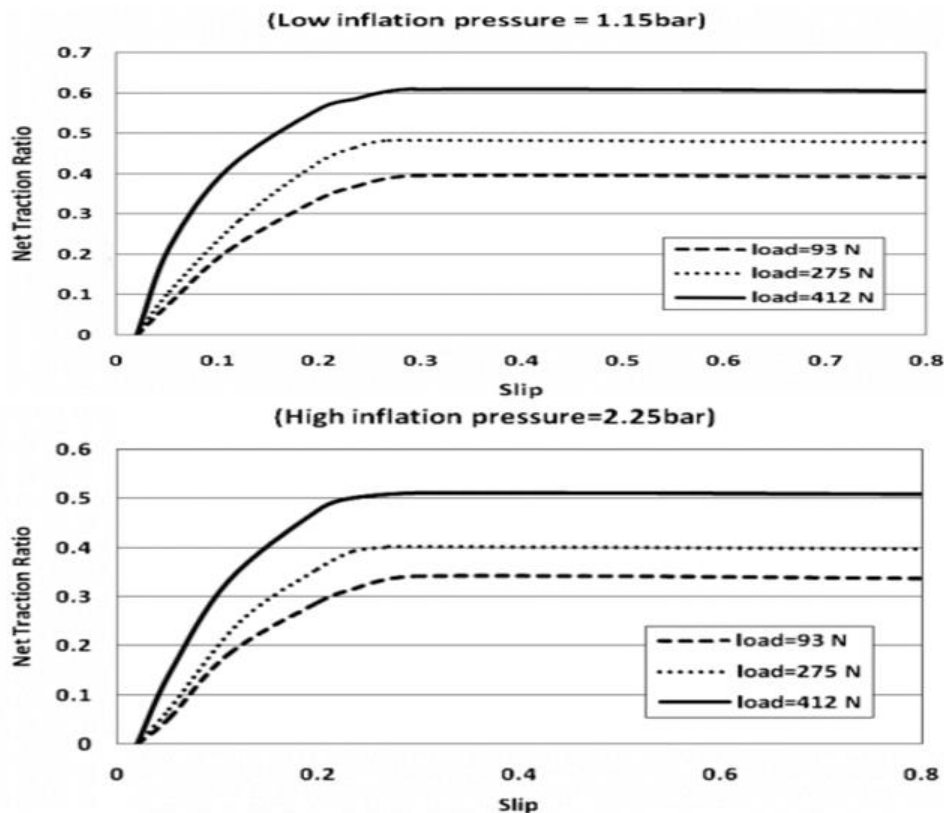

Figure 2.12 Traction ratio against slip different inflation pressure [32]

Another work was published in 2016 with self-inflating system. The inflation and deflation mechanism applied was similar with 'Tyre pressure control system' as discussed using the solenoid valve. This research has better covered inflation range from atmospheric 0 kPa until 500 kPa [33]. The tyre inflation level is measured by offset reading from the pressure sensor after conversion process as:

$$V_{out} = V_{off} (mV) + Sensitivity (mV / KPa) * P (KPa) \quad (2.0)$$

Which includes the sensitivity of the sensor. The experiment result obtained show that the  $V_{out}$  is directly proportional to pressure level as expected.

Shyrokau and his partners analyzed the subsystems coordination during straight-line braking with the tyre pressure inflation system using Hardware-in-loop (HIL) test rig [34]. The proposed test rig consists of hardware and software portions. The hardware consists of the brake system with hydraulic operation and tyre inflation pressure system, whereas the software includes MATLAB/Simulink for tyre motor simulation and multi-body vehicle model from commercial IPG CarMaker. The physical case study of straight-line braking is done with considering the initial velocity at 90 km / h on pavement with low friction coefficient. The result of the case study is shown in Figure 2.13 with respective parameters. From the plotted graph, it clearly shows that the tyre inflation pressure and longitudinal acceleration is directly influenced by the tyre rotation behaviour (straight-line brake). The vehicle acceleration is opposed to the action of brake as expected as braking action will slow down the revolution of a rotating wheel, whereas the inflation pressure level show contradictions which decreased from approximately from 3.5 bars to 2 bars when the action of the brake, this is due to the experimental setup. The tyre inflation level will increase with the action of braking if the tyre is stationary or runs in slow speed.

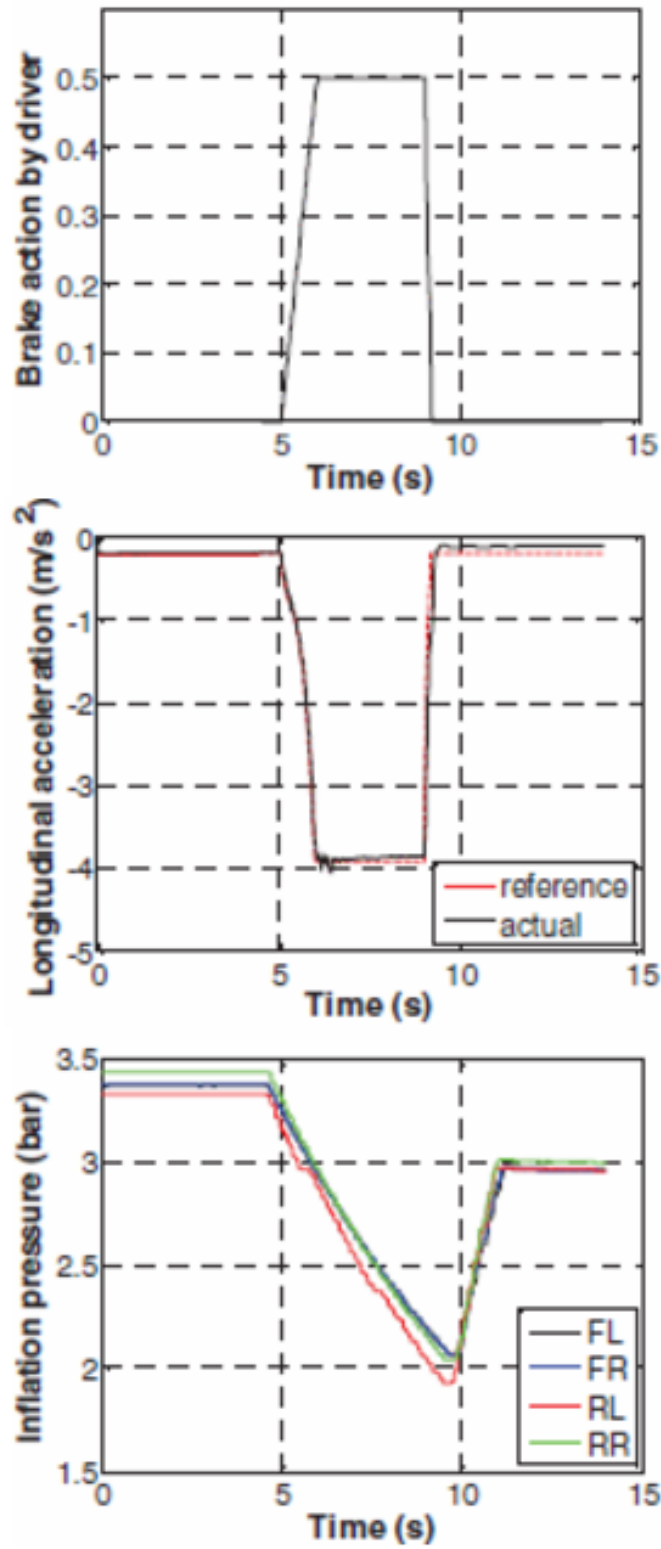

Figure 2.13 Straight-line braking with respect to inflation pressure and acceleration [34]