

**PREPARATION AND CHARACTERIZATION OF CALCIUM COPPER
TITANATE FILLED EPOXY COMPOSITES FOR EMBEDDED
CAPACITOR APPLICATIONS**

by

MOHD SAIDINA BIN DANDAN SATIA

**Thesis submitted in fulfillment of the requirements
for the degree of
Master of Science**

2015

ACKNOWLEDGEMENT

Bismillahirrahmanirrahim. With the name of Allah, The Most Beneficent and The Most Merciful. First of all, I would like to express my gratitude to Allah SWT for the blessing, strength, and each and every ni'mat He bestowed upon me. Alhamdulillah, I have this research completed. Besides that, I would like to express my deepest appreciation to my main supervisor, Professor Ir. Mariatti Jaafar @ Mustapha for her guidance, inspiration and supervision throughout this research. I would also like to extend my gratitude to my co-supervisor Dr. Julie Juliewatty Binti Mohamed for her continuous support in helping to complete my research project.

I also extend my acknowledgement to School of Materials and Mineral Resources Engineering, Universiti Sains Malaysia and the Dean, Professor Hanafi Ismail for provided good facilities to me during my studies here.

Not to forget, my warmest appreciation to all the SMMRE's staffs for their technical support, as well as to my postgraduate friends; Andre Ningkan, 'Irfan, Nurliyana, Chen Ling, Norshamira, Johari, Fariz, Wan Fahmin and Abdul Rashid who always available for discussions.

Warmest appreciation to my father, Hj. Dandan Satia Bin Bukah and my siblings, Mr. Saidani, Ms. Samee'ah, Ms. Syawalliah and Mr. Shahrul Affendi for their motivation, love and endless support.

Last but not least, special thanks to the Ministry of Higher Education, Malaysia and Explorating Research Grant Scheme (ERGS) for granting the research fund used for this project (Project No. 6730109).

TABLE OF CONTENTS

	Page
ACKNOWLEDGEMENT	ii
TABLE OF CONTENTS	iii
LIST OF TABLES	viii
LIST OF FIGURES	x
LIST OF ABBREVIATIONS	xvi
LIST OF MAIN SYMBOLS	xvii
ABSTRAK	xix
ABSTRACT	xx
CHAPTER 1:INTRODUCTION	
1.1 Background	1
1.2 Problem Statements	3
1.3 Objectives	5
1.4 Scope of Work	6
1.5 Dissertation Overview	7
CHAPTER 2:LITERATURE REVIEW	
2.1 Passive Devices	9
2.2 Capacitors	12
2.2.1 Types of Capacitors	14
2.2.1.1 Discrete Capacitors	14
2.2.1.2 Embedded Capacitors	15

2.3	Dielectric Mechanisms	17
2.3.1	Capacitance and Dielectric Constant	17
2.3.2	Dielectric Loss	18
2.4	Filler/Polymer Thin Film Composites	19
2.4.1	Fillers	20
2.4.1.1	Calcium Copper Titanate	20
2.4.1.2	Barium Titanate	21
2.4.1.3	Mica	23
2.4.1.4	Glass-Ceramic Materials	23
2.4.2	Hybrid Fillers	24
2.4.3	Thermosetting Polymers	25
2.4.3.1	Epoxy Resin	26
2.4.3.2	Phenolic Resin	31
2.4.3.3	Polyimide	32
2.5	Factors that Influence the Properties of Ceramic Fillers Filled Polymer Thin Film Composites	33
2.5.1	Effect of Filler Loadings	33
2.5.2	The Fabrication Methods	35
2.5.2.1	Spin Coating	36
2.5.2.2	Hot Press	38
2.5.2.3	Dip Coating	38
2.5.2.4	Solvent Casting	40
2.5.3	Filler Surface Treatment	42
2.6	Research Gap	45

CHAPTER 3: MATERIALS AND METHODOLOGY

3.1	Introduction	47
3.2	Materials	47
3.2.1	Epoxy Resin	47
3.2.2	Curing Agent	48
3.2.3	Calcium Copper Titanate	49
3.2.4	Barium Titanate	50
3.2.5	Silane-based Coupling Agent	50
3.2.6	Ethanol	51
3.3	Experimental Methods	52
3.3.1	Synthesis of CCTO	52
3.3.2	Production of Epoxy Thin Film Composites	53
3.3.2.1	Different Filler Types and Loading Range	53
3.3.2.2	Different Fabrication Methods	55
3.3.2.3	Hybrid Fillers	56
3.3.2.4	Treated CCTO Fillers	57
3.3.2.5	Fabrication of Composites Using Various Epoxy Resins	58
3.4	Characterization Techniques	61
3.4.1	Phase Structure Analysis	61
3.4.2	Microstructures and Element Composition Analysis	62
3.4.3	Particle Size Analysis	63
3.4.4	Functional Groups and Chemical Characteristics Analysis	63
3.5	Dielectric Properties Measurement	64

3.6	Tensile Properties Measurement	65
3.7	Thermal Properties Measurement	66
3.7.1	Thermal Conductivity	66
3.7.2	Thermogravimetric Analysis	67
3.7.3	Dynamic Mechanical Analysis	67
3.7.4	Coefficient of Thermal Expansion Analysis	68

CHAPTER 4: RESULTS AND DISCUSSION

4.1	Introduction	69
4.2	Raw Materials Characterization	69
4.3	The Effect of Different Filler Types and Loading Range	72
4.3.1	Dielectric Properties	72
4.3.2	Tensile Properties	76
4.3.3	Thermal Stability	81
4.3.4	Thermal Conductivity	83
4.3.5	Dynamic Mechanical and Thermal Mechanical Properties	84
4.4	The Effect of Various Fabrication Methods	88
4.4.1	Dielectric Properties	88
4.4.2	Thermal Stability	93
4.4.3	Dynamic Mechanical and Thermal Mechanical Properties	95
4.5	The Effect of Hybrid Fillers	98
4.5.1	Dielectric Properties	98
4.5.2	Thermal Stability	103

4.5.3	Dynamic Mechanical and Thermal Mechanical Properties	104
4.6	The Effect of Silane Coupling Agent	108
4.6.1	Elemental Analysis by Energy Dispersive Spectroscopy (EDS)	108
4.6.2	Fourier-Transform Infrared (FTIR) Analysis	111
4.6.3	Dielectric Properties	113
4.7	The Effect of Various Epoxy Resins	117
4.7.1	Dielectric Properties	118
4.7.2	Thermal Stability	121
4.7.3	Dynamic Mechanical and Thermal Mechanical Properties	123
4.7.4	Comparison of Properties of the Commercial Dielectric Material and the Present Study	126
CHAPTER 5: CONCLUSIONS AND RECOMMENDATIONS		
5.1	Conclusions	128
5.2	Recommendations for Future Research	129
REFERENCES		132
APPENDIX		153
LIST OF PUBLICATIONS		163

LIST OF TABLES

Table 2.1	Comparison between discrete passives and embedded passives (Gerke, 2005)	11
Table 2.2	Various dielectric materials and their properties (Ulrich and Brown, 2006)	13
Table 2.3	Comparison of thin film fabrication methods (Nan, 2006; Yimsiri and Mackley, 2006; Seema et al., 2007)	41
Table 2.4	Overview of research work	46
Table 3.1	General properties of various epoxy resins (Materials Safety Data Sheet)	48
Table 3.2	General properties of various curing agents (Materials Safety Data Sheet)	49
Table 3.3	General properties of CCTO powders (Materials Safety Data Sheet)	50
Table 3.4	General properties of BaTiO ₃ powders (Materials Safety Data Sheet)	50
Table 3.5	General properties of GPTMS (Materials Safety Data Sheet)	51
Table 4.1	Decomposition temperature of various filler loading on epoxy thin film composites	83
Table 4.2	Glass Transition Temperature, T_g and storage modulus, E' of unfilled epoxy and epoxy thin film composites	87
Table 4.3	Decomposition temperature of unfilled epoxy and various filler loading on epoxy thin film composites produced using different	95

fabrication methods

Table 4.4	Glass Transition Temperature, T_g and storage modulus, E' of unfilled epoxy and CCTO/epoxy thin film composites using different fabrication methods	97
Table 4.5	Decomposition temperature of CCTO/epoxy, BaTiO ₃ /epoxy, and hybrid thin film composites	103
Table 4.6	Glass Transition Temperature, T_g and storage modulus, E' of CCTO/epoxy, BaTiO ₃ /epoxy, and hybrid thin film composites	106
Table 4.7	Decomposition temperature of treated CCTO filled DER 332-, Epolam 2015- and OP 392- epoxy thin film composites	122
Table 4.8	Glass Transition Temperature, T_g and storage modulus, E' of treated CCTO/epoxy thin film composites using various epoxy resins	124
Table 4.9	Comparison properties of the commercial dielectric material (3M Embedded Capacitor) and the present study	127

LIST OF FIGURES

Figure 1.1	Structure of a capacitor	2
Figure 2.1	World passive components market (\$billions) (Pfahl and McElroy, 2005)	9
Figure 2.2	Schematic representation of the size advantages of the embedded passives as compared to discrete passives (Lu and Wong, 2008)	10
Figure 2.3	(i) Structure of a capacitor and (ii) general symbol used for capacitor	12
Figure 2.4	Cross-section view of an embedded capacitor and its advantages (Yoon et al., 2009)	16
Figure 2.5	Structure of CCTO (Manik and Pradhan, 2006)	21
Figure 2.6	Structure of BaTiO ₃ (Vijatovic et al., 2008)	22
Figure 2.7	Chemical structure of epoxy group (Bhatnagar, 1996)	26
Figure 2.8	The summarized of the main categories of epoxy resins	27
Figure 2.9	Reaction of epichlorhydrin and bisphenol-A (Paipetis and Kostopoulos, 2012; Dodiuk and Goodman, 2013)	28
Figure 2.10	The chemical structure of novolac epoxy resin (Paipetis and Kostopoulos, 2012)	29
Figure 2.11	The summarized of the main categories of curing agents	30
Figure 2.12	The chemical structure of phenolic resin (Lampman, 2003)	31
Figure 2.13	The chemical structure of polyimide (Lampman, 2003)	32
Figure 2.14	Spin coating process (Sahu et al., 2009)	37
Figure 2.15	Dip coating process; (a-e) batch, (f) continuous (Rahaman, 2007)	39
Figure 2.16	Solvent casting film system (Particle Sciences, 2010)	40

Figure 2.17	Reaction process of silane coupling agents (Arkles, 1977)	44
Figure 3.1	The chemical structure of GPTMS silane-based coupling agent	51
Figure 3.2	Schematic diagram of an ice water bath sonication process	54
Figure 3.3	Flexible epoxy thin film composites filled with (a) CCTO and (b) BaTiO ₃ ceramics	54
Figure 3.4	Spin coating method	55
Figure 3.5	Hot pressing method	56
Figure 3.6	Flexible epoxy thin film composites filled with hybrid fillers with the ratio of CCTO: BaTiO ₃ was varied from (a) 30:70, (b) 50:50 and (c) 70:30	57
Figure 3.7	Overall research flowchart	60
Figure 3.8	The surface of epoxy thin film composites being swapped by silver paste	64
Figure 4.1	XRD patterns of synthesized CCTO and pure BaTiO ₃ powders	70
Figure 4.2	SEM micrographs of (a) synthesized CCTO and (b) pure BaTiO ₃ powders [10000x magnification]	71
Figure 4.3	Particle size distribution for different raw materials, the inset shows the average particles size (d ₅₀) of CCTO and BaTiO ₃ powders	71
Figure 4.4	Dielectric constant of CCTO/epoxy and BaTiO ₃ /epoxy thin film composites as a function of filler loading at frequency of 100 Hz	73
Figure 4.5	Dielectric loss of CCTO/epoxy and BaTiO ₃ /epoxy thin film composites as a function of filler loading at frequency of 100 Hz	73
Figure 4.6	Dielectric constant of 20 vol% CCTO/epoxy and BaTiO ₃ /epoxy thin film composites as a function of frequency	74

Figure 4.7	Dielectric loss of 20 vol% CCTO/epoxy and BaTiO ₃ /epoxy thin film composites as a function of frequency	75
Figure 4.8	Comparison of tensile strength of unfilled epoxy and epoxy thin film composites	77
Figure 4.9	SEM micrograph of fracture surface of (a, b) unfilled epoxy, 5 vol% of fillers; (c, d) CCTO/epoxy, (e, f) BaTiO ₃ /epoxy, and 20 vol% of fillers; (g, h) CCTO/epoxy, (i, j) BaTiO ₃ /epoxy [magnifications of 5000x was used for (a, c, e, g, i), and 10000x for (b, d, f, h, j)]	78
Figure 4.10	Comparison of elongation at break of unfilled epoxy and epoxy thin film composites	80
Figure 4.11	Comparison of elastic modulus of unfilled epoxy and epoxy thin film composites	81
Figure 4.12	Comparison weight loss of unfilled epoxy and thin film composites with respect to temperature, the inset is an enlargement of weight-temperature curve	82
Figure 4.13	Thermal conductivity of CCTO/epoxy and BaTiO ₃ /epoxy thin film composites	84
Figure 4.14	Storage Modulus, E' spectrums recorded at 1 Hz for unfilled epoxy and epoxy thin film composites	85
Figure 4.15	Loss Tangent, $\tan \delta$ spectrums recorded at 1 Hz for unfilled epoxy and epoxy thin film composites	87
Figure 4.16	Dielectric constant of CCTO/epoxy thin film composites as a function of frequency using spin coating (SC) and hot press (HP) methods	90

- Figure 4.17 Dielectric loss of CCTO/epoxy thin film composites as a function 91
of frequency using spin coating (SC) and hot press (HP) methods
- Figure 4.18 SEM micrograph of fracture surface of epoxy thin film composites 92
(**a, b**) 20vol% CCTO/epoxy (SC), (**c, d**) 20vol% CCTO/epoxy
(HP), (**e, f**) 30 vol% CCTO/epoxy (HP) (**g, h**) 40 vol%
CCTO/epoxy (HP) [magnifications of 1000x was used for (**c, e, g**),
1500x for (**a**) and 5000x for (**b, d, f, h**)]
- Figure 4.19 Comparison weight loss of unfilled epoxy and CCTO/epoxy thin 94
film composites produced using different fabrication methods with
respect to temperature, the inset is an enlargement of weight-
temperature curve
- Figure 4.20 Storage Modulus (E') spectrums recorded at 1 Hz for unfilled 96
epoxy and CCTO/epoxy thin film composites produced using
different fabrication methods
- Figure 4.21 Loss tangent, $\tan \delta$ spectrums recorded at 1 Hz for unfilled epoxy 97
and CCTO/epoxy thin film composites produced using different
fabrication methods
- Figure 4.22 Dielectric constant of hybrid fillers and single filler filled epoxy 99
thin film composites according to the ratio of CCTO:BaTiO₃ at
frequency of 100 Hz
- Figure 4.23 Dielectric loss of hybrid fillers and single filler filled epoxy thin 100
film composites according to the ratio of CCTO:BaTiO₃ at
frequency of 100 Hz
- Figure 4.24 SEM micrograph of fracture surface of (**a, b**) 20 vol% 101
CCTO/epoxy, (**c, d**) 20 vol% BaTiO₃/epoxy and hybrid fillers

filled epoxy thin film composites according to the ratio of CCTO : BaTiO₃; **(e, f)** 30:70 ratio, **(g, h)** 50:50 ratio, and **(i, j)** 70:30 ratio [magnifications of 5000x was used for **(a, c, e, g, i)**, and 10000x for **(b, d, f, h, j)**]

- Figure 4.25 Comparison weight loss of CCTO/epoxy, BaTiO₃/epoxy, and hybrid thin film composites with respect to temperature, the inset is an enlargement of weight loss-temperature curve 104
- Figure 4.26 Storage Modulus, E' spectrums recorded at 1 Hz for unfilled epoxy, CCTO/epoxy, BaTiO₃/epoxy, and hybrid thin film composites 105
- Figure 4.27 Loss Tangent, $\tan \delta$ spectrums recorded at 1 Hz for CCTO/epoxy, BaTiO₃/epoxy, and hybrid thin film composites 107
- Figure 4.28 EDS analysis on untreated CCTO filler; (a) Spot taken for EDS analysis and (b) EDS spectrum shows the absence of Si element on the surface of CCTO particles 109
- Figure 4.29 EDS analysis on treated CCTO filler; (a) Spot taken for EDS analysis and (b) EDS spectrum shows the presence of Si trace on the surface of CCTO particles 110
- Figure 4.30 FTIR spectra of (a) untreated CCTO/epoxy and (b) treated CCTO/epoxy 112
- Figure 4.31 Schematic illustration of the action mechanism of silane coupling agent during the formation of interface between CCTO fillers and epoxy matrix 113
- Figure 4.32 Dielectric constant of untreated and treated CCTO/epoxy thin film composites as a function of frequency 114

Figure 4.33	Dielectric loss of untreated and treated CCTO/epoxy thin film composites as a function of frequency	115
Figure 4.34	SEM micrograph of fracture surface of treated 20 vol% CCTO/epoxy thin film composites at different concentration of silane coupling agent (a) 1%, (b) 5% and (c) 10% [magnifications of 10000x]	116
Figure 4.35	Dielectric constant of treated CCTO filled DER 332, Epolam 2015 and OP 392 epoxy thin film composites	118
Figure 4.36	Dielectric loss of treated CCTO filled DER 332, Epolam 2015 and OP 392 epoxy thin film composites	119
Figure 4.37	SEM micrograph of fracture surface of treated CCTO/epoxy thin film composites at different types of epoxy resins; (a, b) Epolam 2015, (c, d) OP 392 [magnifications of 5000x was used for (a, c) and 10000x for (b, d)]	120
Figure 4.38	Comparison weight loss of treated CCTO/epoxy thin film composites using various epoxy resins with respect to temperature, the inset is an enlargement of weight loss-temperature curve	122
Figure 4.39	Storage Modulus, E' spectrums recorded at 1 Hz for treated CCTO/epoxy thin film composites at different types of epoxy resins	123
Figure 4.40	Loss Tangent, $\tan \delta$ spectrums recorded at 1 Hz for treated CCTO/epoxy thin film composites at different types of epoxy resins	125

LIST OF ABBREVIATIONS

PCB	Printed Circuit Board
$\text{CaCu}_3\text{Ti}_4\text{O}_{12}$ (CCTO)	Calcium Copper Titanate
BaTiO_3	Barium Titanate
GPTMS	3-glycidoxypropyltrimethoxysilane
TGA	Thermogravimetric Analysis
DMA	Dynamic Mechanical Analysis
TMA	Thermo-Mechanical Analysis
MLC	Multilayer Capacitor
DGEBA	Diglycidyl ether of bisphenol-A
NaOH	Sodium Hydroxide
CTE	Coefficient of Thermal Expansion
XRD	X-ray Diffraction
SEM	Scanning Electron Microscope
FTIR	Fourier-Transform Infrared
EDS	Energy Dispersive Spectroscopy
SC	Spin Coating
HP	Hot Press

LIST OF MAIN SYMBOLS

%	Percentage
°C	Degree Celsius
°C/min	Degree Celsius per minutes
MPa	Megapascal
g	Gram
nm	Nanometer
μm	Micrometer
mm	Millimeter
g/cm ³	Gram per cubic centimeters
vol %	Volume percent
\$	U.S Dollar
s	Second
min	Minutes
h	Hour
ε	Permittivity
tan δ	Tangent loss
Hz	Hertz
MHz	Megahertz
GPa	Gigapascal
%	Percentage
F	Farads
F/m	Farads per meter
K	Kelvin

T_g	Glass Transition Temperature
$T_{5\%}$	Initial Degradation Temperature
T_{onset}	Onset Decomposition Temperature
T_c	Curie Temperature
kV/mm	Kilovolt per millimeter
J/cm ³	Joule per cubic centimeters
mPa.s	Millipascal-second
rpm	Rotation per minute
psi	Pounds per square inch
ml	Milliliter
cm ⁻¹	One per centimeter

**PENGHASILAN DAN PENCIRIAN KOMPOSIT EPOKSI TERISI
KALSIUM KUPRUM TITANAT UNTUK APLIKASI KAPASITOR**

TERBENAM

ABSTRAK

Permintaan yang semakin meningkat untuk pengecilan peranti elektronik menawarkan pengurangan saiz yang ketara, prestasi dielektrik dan haba yang lebih baik, kebolehpercayaan dan kos yang lebih rendah. Komposit polimer-seramik telah dipilih sebagai bahan dielektrik yang paling sesuai untuk kapasitor terbenam. Dalam kajian ini, seramik seperti kalsium kuprum titanat, $\text{CaCu}_3\text{Ti}_4\text{O}_{12}$ (CCTO) dan barium titanat (BaTiO_3) telah digunakan sebagai pengisi dalam komposit epoksi filem nipis. Sifat-sifat komposit epoksi filem nipis dihasilkan berdasarkan muatan pengisi yang berbeza (5 hingga 20% isipadu), kaedah fabrikasi seperti salutan putaran (SC) dan tekan panas (HP), pengisi hibrid (CCTO dan BaTiO_3), rawatan permukaan pengisi dan pelbagai jenis resin epoksi (DER 332, Epolam 2015 dan OP 392) telah dikaji. Keputusan menunjukkan bahawa komposit CCTO/epoksi mempamerkan pemalar dielektrik, T_g dan kekonduksian haba yang lebih tinggi berbanding dengan epoksi tidak terisi dan komposit BaTiO_3 /epoksi. Dalam siri kedua, pengisi CCTO untuk pengisian komposit epoksi telah dipilih untuk siasatan lanjutan. Komposit CCTO/epoksi dengan pengisian sehingga 40% isipadu dapat dihasilkan dengan menggunakan kaedah HP. Hasil ujian telah menunjukkan bahawa sifat-sifat komposit 40% isipadu CCTO/epoksi (HP) telah meningkat sebanyak 55% pemalar dielektrik dan 83% modulus simpanan, dan penurunan 69% pekali pengembangan haba berbanding dengan sifat-sifat komposit 20% isipadu CCTO/epoksi (SC). Pengisi Hibrid untuk pengisian komposit epoksi telah dihasilkan dan keputusan menunjukkan bahawa Hibrid 70:30 mempamerkan kesan hibrid yang positif berbanding dengan komposit pengisi tunggal; komposit filem nipis CCTO/epoksi dan BaTiO_3 /epoksi. Selepas rawatan CCTO oleh ejen gandingan silana, sampel komposit epoksi terisi CCTO 10% yang terawat menunjukkan peningkatan yang memberangsangkan iaitu sebanyak 60% pemalar dielektrik berbanding komposit filem nipis CCTO/epoksi yang tidak terawat. Berdasarkan pelbagai resin epoksi, komposit filem nipis CCTO/epoksi OP 392 yang terawat mempamerkan kenaikan pemalar dielektrik sebanyak 10% dan susutan dalam pekali pengembangan haba sebanyak 38% berbanding dengan bahan dielektrik komersial, iaitu 3M Embedded Capacitor. Secara kesimpulannya, komposit filem nipis CCTO/epoksi OP 392 yang terawat menunjukkan prestasi yang baik dari segi pemalar dielektrik dan haba berbanding komposit CCTO yang tidak terawat, komposit hibrid dan lain-lain komposit terawat.

**PREPARATION AND CHARACTERIZATION OF CALCIUM COPPER
TITANATE FILLED EPOXY COMPOSITES FOR EMBEDDED
CAPACITOR APPLICATIONS**

ABSTRACT

Continuous miniaturization of electronic devices result in a high demand of embedded capacitor that offers significant reduction in size, better dielectric and thermal performance, reliability and lower cost. Polymer-ceramic composites have been considered as the most suitable dielectric materials for embedded capacitor. In this study, ceramics such as calcium copper titanate, $\text{CaCu}_3\text{Ti}_4\text{O}_{12}$ (CCTO) and barium titanate (BaTiO_3) were used as fillers in epoxy thin film composites. The properties of epoxy thin film composites fabricated based on different filler loading (5 to 20 vol%), fabrication methods such as spin coating (SC) and hot press (HP) methods, hybrid fillers (CCTO and BaTiO_3), surface treatment of filler and various types of epoxy resins (DER 332, Epolam 2015 and OP 392) were characterized. Results showed that CCTO/epoxy composite exhibited higher dielectric constant, T_g and thermal conductivity compared to those of unfilled epoxy and BaTiO_3 /epoxy composites. In the second series, CCTO filler filled epoxy composite was chosen for further investigation. CCTO/epoxy composite with filler loading of up to 40 vol% was able to be produced by using HP method. It was found that 40 vol% CCTO/epoxy (HP) composite has increased 55% of dielectric constant and 83% of storage modulus, and decreased 69% of CTE compared to 20 vol% CCTO/epoxy (SC) composite. Hybrid fillers composites were fabricated and results indicated that Hybrid 70:30 showed positive hybrid effect compared to those of single filler composites; CCTO/epoxy and BaTiO_3 /epoxy thin film composites. After treatment of CCTO by silane-based coupling agent, sample with 10% treated CCTO filled epoxy composite presented remarkable improvement with an increased 60% of dielectric constant than untreated CCTO/epoxy thin film composite. Based on various epoxy resins, treated CCTO/OP 392 epoxy thin film composite has improved 10% of dielectric constant and decreased 38% of CTE compared to 3M Embedded Capacitor. In short, treated CCTO filled OP 392 epoxy thin film composite exhibited good dielectric properties and thermal properties compared to those of untreated CCTO composites, hybrid fillers composites and other treated composites.

CHAPTER 1

INTRODUCTION

1.1 Background

Passive components such as resistors, capacitors and inductors are widely used in the microelectronic packaging industry (Wu et al., 2007). These components refer to the type of electrical components that cannot generate power. Nearly 80% of the printed circuit board (PCB) is occupied by passive components, therefore research on the passive component are still developing so that the number of passives is steadily growing with high functionality of electronic devices (Rao et. al, 2002). Most of the passive components used today are discrete surface mount passive components which is directly mount on the surface of a PCB. Among passive components, capacitor plays important role in electronic device which is used to store energy in electric field.

A capacitor is a passive two terminal component which is used to store electric charge. It has a sandwich type of structure as illustrated in Figure 1.1. Stephen (2001) reported that the structure has two parallel conductive plates (T) and a dielectric in the middle with its capacitance value in Farads. It is then being fixed by the surface area of the conductive plates (S) and the distance of separation between them (D). A capacitor should provide high storage of charge, stable capacitance over a broad temperature range and low losses for the device to maintain its charge and to avoid self-heating. Moreover, other practical requirements are packaging and reliability at high temperature, as well as cost efficiency which excludes the used of expensive elements to a large extent.

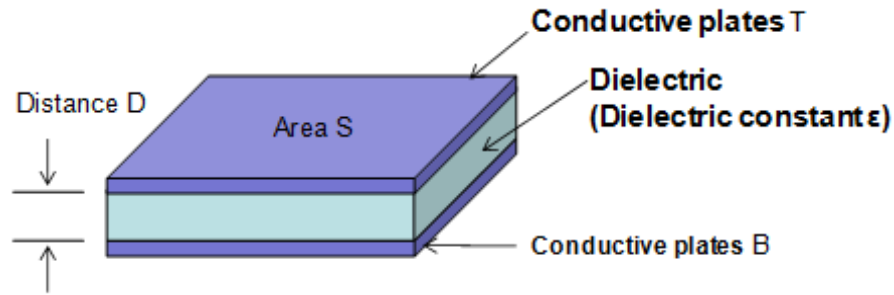

Figure 1.1: Structure of a capacitor

There are two types of capacitor that is widely used in the market, discrete capacitor and embedded capacitor. The primary advantages of embedded capacitor over discrete capacitor include size and weight reduction, better reliability, excellent electrical performance and easy processing. It is worth noting that composites consisting of the ceramic filler and polymer matrix have been considered as one of the most promising materials for embedded capacitors. Compared with the ceramic fillers, the polymer can be processed under low temperature and their processing method can be controlled easily. Besides, owing to their higher breakdown strength, the embedding polymer can improve the breakdown performance of embedded capacitors. The ceramic fillers have high dielectric permittivity, which can enhance the dielectric properties of the capacitors. Hwu et. al (2005), Yoon et. al (2009) and Luo et. al (2009) proved that by incorporating the ceramic fillers into polymer matrix can well combine their advantages to optimize overall properties of embedded capacitor.

Previous studies reported that epoxy resin is one of the most common type of thermosetting resin used in electronic packaging applications. Epoxy resin offers advantages in terms of flexibility, compatibility, low processing temperature and can be easily fabricated into various shapes. However, the dielectric constant of epoxy

resin is low which is not suitable to be used as dielectric material for embedded capacitor. Therefore, by incorporating epoxy resin with ceramic filler can produce epoxy composites with high dielectric constant (Alam et. al, 2011).

Based on the dielectric constant value, one of the most promising materials that can be used as ceramic fillers in epoxy resin is Calcium Copper Titanate, $\text{CaCu}_3\text{Ti}_4\text{O}_{12}$ (CCTO). CCTO ceramic which has centrosymmetric *bcc* structure (space group $\text{Im}\bar{3}$, lattice parameter $a \approx 0.7391\text{nm}$, and $Z = 2$), has been used as a filler due to lead-free, environment friendly and high dielectric constant ceramic which is about $\sim 10^5$ (Subramanian et. al, 2000; Homes et. al, 2001).

1.2 Problem Statements

Recently, the miniaturization in electronic devices has been a clear trend in the market due to the demand on the compactness, better performance, light weight and low cost of electronics. This phenomenon has driven changes in the electronic packaging requirements from discrete capacitor to embedded capacitor. Embedded planar capacitors are thin laminates embedded inside a substrate or PCB that serve both as a power or ground plane and as a parallel plate capacitor. As reported by Lee et al. (2007), Xu et al. (2007) and Das et al. (2008), polymer-ceramic composites have been pursued as the most promising dielectric materials for embedded capacitors in the organic package due to lower processing temperature ($<250^\circ\text{C}$), high flexibility and lower cost.

Pure ceramics such as Barium Titanate, BaTiO_3 has high dielectric constant which is about ~ 1000 , but pure BaTiO_3 is still not suitable to be used as dielectric material as the processing temperature of BaTiO_3 is higher than PCB manufacturing

process and incorporation of BaTiO₃ ceramic into epoxy resin produced composites with low dielectric constant which is about 8 (measured at 100 Hz) at 20 vol% loading of BaTiO₃ filler (Duran et al., 2002; Zhang et al., 2014). Due to that, CCTO has received great attention by many researchers because of its giant dielectric constant which is about ~10 000 as compared to BaTiO₃ ceramic (Subramanian et al., 2000; Homes et al., 2001). According to the previous reports, by increasing CCTO loadings in polymer matrix system, dielectric properties of composites can be improved (Ramajo et al., 2008; Thomas et al., 2013). However, reports on thermal properties of CCTO filler filled epoxy matrix are very limited. Thermal properties such as glass transition temperature (T_g), storage modulus and thermal stability of CCTO/epoxy composite are important to be identified for electronic applications.

A combination of fillers in certain polymer matrices or hybrid composites is getting acceptance from many researchers (Weon and Sue, 2006; Deshmukh et al., 2011). Hybrid composites produce significant effects because the combination of two types of fillers may balance the performance of polymer composites that cannot be obtained when only a single filler is used (Kord, 2011). According to Etika et al. (2009), Helmi et al. (2013) and Luo et al. (2014), addition of hybrid fillers into polymer matrix can greatly enhance the properties of the composites as compared to single filler. This could be due to different shape, aspect ratio and dispersion characteristics of the two different fillers that could improve the properties of the composites.

Apart from that, the fabrication methods of epoxy thin film composites, filler treatment, types of epoxy resins, filler-matrix adhesion, filler dispersion in epoxy matrix and types of epoxy resins used in the preparation of epoxy composites play an

important role in determining the final properties of the composites. Based on the literature studies, the silane-based coupling agent showed an improvement in the properties of the polymer composites compared to untreated polymer composites due to better dispersion of filler in epoxy matrix (Todd and Shi, 2003; Hirano et al., 2012; Yang et al., 2013). The silane-based coupling agent acts as a bridge in between the filler and the matrix which then enhanced the filler-matrix bonding and subsequently improve the final properties of the composites. Electronic packaging application requires properties such as high dielectric constant, low dielectric loss, good mechanical strength, high thermal stability, high T_g and low CTE value. Therefore, in this study, those properties have been investigated.

1.3 Objectives

The present study mainly investigates the effect of incorporation ceramic filler in epoxy matrix system. The knowledge obtained from this investigation will be useful in selecting the most desirable dielectric materials with excellent dielectric, tensile and thermal properties for embedded capacitor. The main objectives of the present study are as follows:

1. To study the effect of different filler types and filler loading range on the dielectric, tensile and thermal properties of epoxy thin film composites
2. To compare the effect of spin coating method and hot press method on the dielectric and thermal properties of ceramic filler filled epoxy thin film composites
3. To investigate the effect of hybrid fillers on the dielectric and thermal properties of epoxy thin film composites

4. To determine the effect of silane coupling agent on the properties of CCTO/epoxy thin film composites
5. To compare the effect of various epoxy resins on the dielectric and thermal properties of CCTO filled epoxy thin film composites

1.4 Scope of Work

The present studies focus on the production of epoxy thin film composites by studying the filler types and loading range. Two types of filler, namely CCTO and BaTiO₃ ceramics are used in this study. The loading of the ceramic filler in the epoxy resin is varied from 5 vol% to 20 vol%. Besides that, unfilled epoxy is also prepared for comparison purpose. The second phase of study concentrates on the effect of several fabrication methods on the final properties of composites. CCTO ceramic is further used as a filler for the preparation of epoxy composites at two different fabrication methods which includes spin coating method and hot pressing method. This study is continued by studying the effect of hybrid fillers, which is believed can improve the properties of epoxy thin film composites. 20 vol% of hybrid fillers (CCTO and BaTiO₃ ceramics) are used at different ratio of hybrid fillers of CCTO: BaTiO₃ which is varied from 30:70, 50:50 and 70:30, respectively. Moreover, silane-based coupling agent known as 3-glycidoxypropyltrimethoxysilane (GPTMS) is chosen in order to improve the interfacial adhesion between CCTO filler and epoxy resin. Lastly, CCTO filler was used as a filler in two types of epoxy resins; Epolam 2015 and OP 392. Comparison of properties of the epoxy thin film composites with epoxy DER 332 thin film composite were made.

The present study is mainly focused on the investigation of dielectric, tensile and thermal properties of the composites using various characterization techniques such as dielectric properties analyzer, tensile properties analyzer, TGA, DMA, TMA and thermal conductivity analyzer. The results are also supported by the morphology of fractured samples of the composites.

1.5 Dissertation Overview

Chapter 1 starts with a brief introduction of passive components which is important in electronic packaging applications. This chapter also includes some of the problem statements for passive components, especially capacitors. The objectives of the research project are described in this chapter.

Chapter 2 consists of literature review on the recent progress made in embedded capacitor research area which includes the definition, classification and applications.

Chapter 3 describes the overall research flowchart in the present study, followed by materials used in the experiment and experimental procedures. The characterization methods are also discussed in this chapter.

Chapter 4 reports the characterization of raw materials used in the preparation of ceramic filler filled epoxy thin film composites. This chapter is further divided into four parts. The first part discussing the effect of filler types and loading range on the properties of epoxy composites. The second part describes the effect of fabrication methods on the dielectric and thermal properties of epoxy composites, followed by the effect of hybrid fillers on the properties of epoxy thin film composites. Next, the properties of treated CCTO in epoxy thin film composites are

studied and compared with the untreated CCTO/epoxy thin film composites. Lastly, the properties of epoxy thin film composites fabricated by using different types of epoxy resins are compared.

Chapter 5 presents the conclusions from this research and also some recommendations for future studies in this related field.

CHAPTER 2

LITERATURE REVIEW

2.1 Passive Devices

Passives often called as the key functional elements in all electronic systems. It represent a world wide market of \$20 billion per year as illustrated in Figure 2.1. Passives refer to resistors, capacitors and inductors, and usually exist in all of the electronic system to provide impedance, current-to-voltage phase angle and energy storage. Moreover, passive components are nonswitching, have no gain and cannot amplify as compared to active components. These components perform vital functions such as bias, decoupling, filtering and terminations in order to provide proper operations of all electronic systems. There are more than ten discrete passives used for every active component in a typical system which account for 90% of components, 40% of board area and 30% of solder joints in typical systems (Tummala, 2001; Ramkumar et al., 2006; Bhalerao, 2008; Lu, 2008).

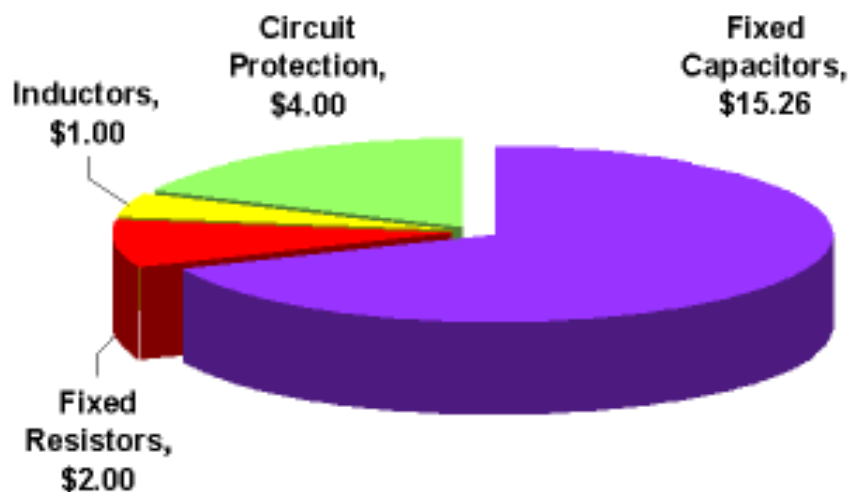

Figure 2.1: World passive components market (\$billions) (Pfahl and McElroy, 2005)

As the trend towards miniaturization, lighter weight, faster, high reliability and low cost electronic devices increases over the years, passive technology has switched from discrete passives to integrated passives and recently, embedded passives. Embedded passives have been introduced in which the passive components are embedded or buried within the board itself as depicts in Figure 2.2. This is an alternative to smaller discrete passives and complex integrated passives. It provides many advantages such as reduction in size and weight, improved reliability and speed, improve performance and reduced cost as compared to discrete passives and integrated passives (Lu and Wong, 2008).

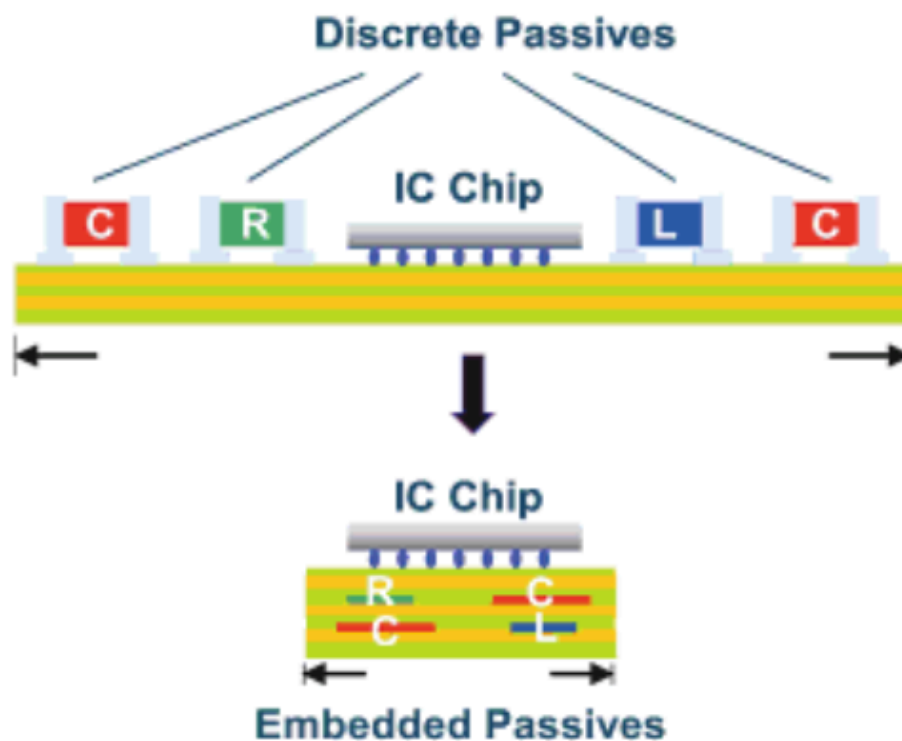

Figure 2.2: Schematic representation of the size advantages of the embedded passives as compared to discrete passives (Lu and Wong, 2008)

Table 2.1 shows the comparison between discrete passives and embedded passives. Despite of numerous advantages that have been offered by embedded passives, they still have limitations too. It shows that the rework and manufacturing costs of embedded passives are low except the components and materials costs. Gerke (2005) illustrated that once the materials and design are set, the manufacturing and other costs associated with assembly are small. Furthermore, the overall risk of embedded technologies are high even the design flexibility is little, this is because if the passive values are incorrect, the board will have to be scrapped.

Table 2.1: Comparison between discrete passives and embedded passives (Gerke, 2005)

	Discrete Passives	Embedded Passives
Overall cost	High	Low
Circuit board cost	High	Low
Manufacturing cost	High	Low
Board area consumed	Large	Small
Machine set-up time	Long	Fast
Yield	Low	High
Electrical performance (especially at high frequency)	Good	Better
Components costs	Low	High
Materials costs	Low	High
Design flexibility	Large	Little
Risk	Low	High

2.2 Capacitors

A capacitor is defined as two conductors (conductive plates) which separated by a non-conductive region also known as dielectric as illustrated in Figure 2.3 (i). The conductors may be plates, foil, solid shapes or even wires, whereby for dielectric, it can be glass, air, vacuum, paper, oxide layer on metal (as in electrolytic capacitors), flat thin paper or film, placed or even wound on the conductors. Figure 2.3 (ii) shows the general symbol used for capacitor. Generally, a capacitor is used to store and release electrical energy. It can also be used to smooth out current fluctuations, store and release a high voltage or block DC voltage.

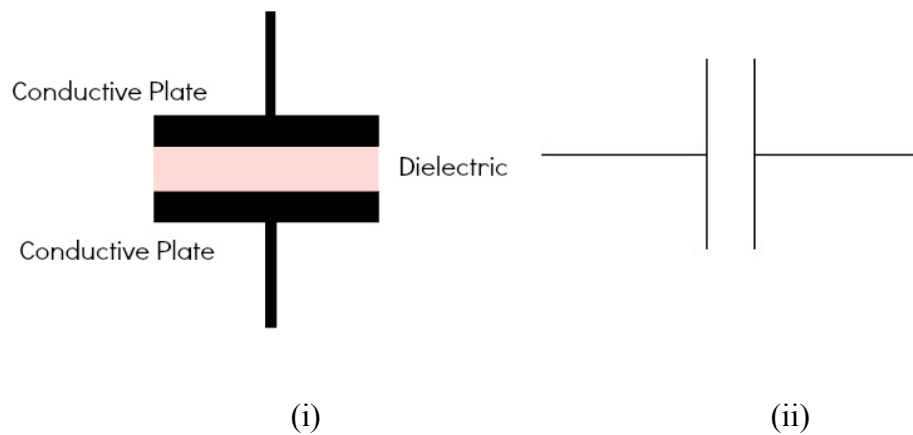

Figure 2.3: (i) Structure of a capacitor and (ii) general symbol used for capacitor

Paraelectrics and ferroelectrics are the main types of dielectric materials. Paraelectric materials tend to have much lower dielectric constant than those of ferroelectric materials but they are more stable with respect to temperature, frequency, film thickness, bias, voltage and time. Therefore, paraelectrics are more suitable for high tolerance applications including filtering, timing and more. Whereby for ferroelectrics, it would be preferred for decoupling because of higher dielectric constants and less tolerance. Table 2.2 presents various dielectric materials

and their properties. Paraelectrics and ferroelectrics can be further divided into four classes such as thin film oxides, unfilled polymers, ferroelectrics and ferroelectric filled polymers (Ulrich, 2000; Rao, 2001; Pfahl and McElroy, 2005).

Table 2.2: Various dielectric materials and their properties (Ulrich and Brown, 2006)

Dielectric Materials	Dielectric Constant
Epoxies	3 – 5
Unlimited laminated polymer	4
Ferroelectric filled polymer	50
Spin-on BCB	2.7
SiO ₂	3.7
Al ₂ O ₃	9
Ta ₂ O ₅	24
TiO ₂	40
BaTiO ₃	~ 1000

The examples of paraelectric materials are thin film oxides and unfilled polymers. Thin film oxides such as SiO₂, Ta₂O₅, TiO₂, Al₂O₃ and BCB have higher dielectric constant than those of unfilled polymers. However, unfilled polymers offer simple processing conditions and lower processing cost per area as compared to thin film oxides. Ferroelectrics such as barium titanate, BaTiO₃ offer very high dielectric constant and therefore, possesses the highest energy density in ferroelectric materials which is useful for energy storage applications. However, BaTiO₃ is strongly affected by environment and operating condition such as temperature, frequency,

voltage and time. It also cannot be directly implemented on the organic substrates as the material must be annealed onto a separate copper foil first and oxygen is required during firing process. Ferroelectric filled polymers are the combinations of paraelectrics and ferroelectrics. Few advantages can be obtained by combining both types such as high dielectric constant and compatible processing conditions for organic substrates. For example, by adding ferroelectric material such as BaTiO₃ into paraelectric material such as epoxy resin or polyimide, relatively high dielectric constant can be obtained at low processing temperature.

2.2.1 Types of Capacitors

Capacitors have been created in various physical forms which presently exists in today's electronic market. There are two types of capacitors such as discrete capacitors and embedded capacitors. These topics will be discussed in the next sections.

2.2.1.1 Discrete Capacitors

The discrete capacitors are known as single component or integrated arrays that are enclosed in a single enclosure and mounted on an interconnecting substrate. This type of capacitors are the most common form of capacitors widely used in today's electronics. The examples of discrete capacitors including film capacitors, ceramic capacitors, mica capacitors, electrolytic capacitor and solid tantalum capacitors (Sarjeant et al., 1999; Jain and Rymaszewski, 2003).

A film capacitors can be described as non-polarized capacitors with an insulating plastic film as the dielectric and electrode plates. Various plastic films

have been used for film capacitors such as polypropylene, polyester, polycarbonate and polyimide. However, polypropylene and polyester become the most popular materials for surface-mount film capacitors (Cozzolino and Ewell, 2002).

Meanwhile for ceramic capacitors, it refers to non-polarized fixed capacitor made from two or more alternating layers of ceramic and metal in which the ceramic material acts as the dielectric and the metal acts as the electrodes. The main types of ceramic capacitor that is often used in electronic equipments are the multi-layer ceramic capacitor which is also known as MLCC (Pabst and Gregorová, 2007).

However, in the latest technology, as the demand to miniaturize the devices increase, discrete capacitors can be no longer fit to the trend of technology. These discrete capacitors not only occupies large surface area of the substrate, but also provide low electrical and reliability performance due to increment of interconnection length and number of solder joint. Therefore, to solve these problems, embedded passive component technology was introduced (Rao et. al, 2002).

2.2.1.2 Embedded Capacitors

Embedded capacitors are basically integrated inside the substrate in which can bring miniaturization to corresponding devices and therefore it will replace current discrete capacitors and can be used in the next generation modern electronics (Choa et al., 2004; Zhang et al., 2012). Embedded capacitors offer many advantages such as size reduction, cost reduction, improve in electrical performance and also improve the reliability performance of an electronic system due to elimination of the solder joints that are required by discrete components (Sandborn, 2003; Choa et. al,

2004; Lu et. al, 2007; Lu and Wong, 2008; Wu et. al, 2009). Figure 2.4 shows the cross sectional view of an embedded capacitor and the summarized advantages of embedding thin film capacitors in a microelectronics packaging (Kim et al., 2009).

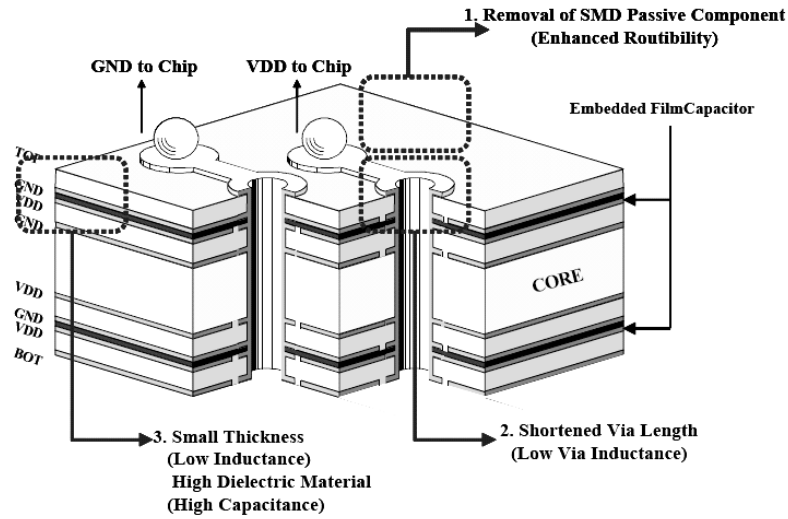

Figure 2.4: Cross-section view of an embedded capacitor and its advantages
(Yoon et al., 2009)

In previous works, ceramic materials are usually considered to possess giant dielectric constant and low dielectric loss. Cho et al. (2004) reported that BaTiO_3 was chosen as a ceramic material due to its high dielectric constant. The dielectric constant of bulk BaTiO_3 ceramics increased with decreasing of grain sizes up to approximately 700nm. However, ceramic materials possess high sintering temperature, high production cost and poor processability. Therefore, it is not suitable to be used as dielectric materials for embedded capacitors (Bhattacharya et al., 2000). Meanwhile, polymers are flexible in nature, can be processed at much lower temperature, low dissipation factors, high dielectric breakdown strength and good dielectric stability over a wide range of frequencies and temperatures (Bai et

al., 2000).

Generally, to embed capacitor into the substrate, the dielectric materials must be easily processed in a manner compatible with the low-temperature manufacturing process of an organic substrate. Due to that, ceramic filler filled polymer system become one of the most promising materials for embedded capacitor. It utilizes high dielectric constant of ceramic powders and good processability of polymers resulting in lower temperature process about less than 250 °C and lower cost (Bhattacharya et al., 2000; Bhattacharya et al 2001; Rao et al., 2002).

2.3 Dielectric Mechanisms

The following topics discussed about the basic concepts with suitable examples of capacitance, dielectric constant and dielectric loss.

2.3.1 Capacitance and Dielectric Constant

The ability of a capacitor to store an electric charge is called capacitance (C). Capacitance can be simply stated as the amount of charge that a capacitor is capable of holding per unit of voltage applied. It is measured in units called farads (F), basically describes as the number of coulombs of charge that can be placed on each conductor causes a voltage of one volt across the device. Capacitance in the range of picofarad (10^{-12}) to microfarad (10^{-6}) are widely used for typical electrical circuit (Adhami et al., 2007; Deshpande, 2012; Erjavec, 2013). Equation 2.1 shows how capacitance with a vacuum dielectric layer, C_o is related to stored charge and applied voltage.

$$C = \frac{Q}{\Delta V} = \frac{Q}{Qd/\epsilon_0 A} = \frac{\epsilon_0 A}{d} \quad (2.1)$$

where Q is the charge applied, V is the voltage applied, ϵ_0 is the vacuum permittivity (8.854×10^{-12} F/m), A is the area of the electrical conductor and d is the distance between the conductors. Noted that, the capacitance can be maximized if the capacitor plates have larger area and the distance between the conductors are placed together as close as possible.

The dielectric constant (k or ϵ_r) is known as relative permittivity in which the ratio of permittivity of dielectric medium over permittivity of a vacuum (Sharif, 2010; Fariz, 2013). It also represents the ability of a capacitor to store charge in a capacitor. The relationship between capacitance (C) and dielectric constant (k or ϵ_r) are shown in Equation 2.2.

$$C = \frac{\epsilon_0 \epsilon_r A}{d} \quad (2.2)$$

It is evident that the larger the dielectric constant, the more the charge the capacitor can store in a given field and the higher the capacitance at a given space. Therefore, it is crucial to have materials with high dielectric constant for the application of capacitor.

2.3.2 Dielectric Loss

The dielectric loss is a measure of the energy so dissipated in the dielectric in the form of heat. It also can be called as dissipation factor or loss tangent ($\tan \delta$). Dielectric loss can be further separated into two forms including relaxation effect and

conduction loss. Fowler (1994) and Sirdeshmukh et al. (2006) stated that dielectric loss occurs because of the dipoles that continually reorient with the field. A little electric energy will be dissipated or converted into the heat energy on every time the molecular structure of the dielectric material has to adjust to a new polarity. This phenomenon is known as relaxation effect.

The dielectric loss is also influenced by the flow of charge passing through the material which causes energy dissipation. This phenomenon is often called as the conduction loss. It usually shows a linear log ($\tan \delta$) against frequency plot, whereby the loss caused by the relaxation effect shows a maximum at a certain frequency (Sirdeshmukh et al., 2006).

2.4 Filler/Polymer Thin Film Composites

Polymer composites can be described as materials which consists normally of two discrete phases, a continuous matrix phase which is often a resin and a discontinuous filler phase made up of discrete particles (Han, 1981). The reinforcement materials which are stiffer and stronger than the matrix are impregnated in order to enhance mechanical and physical properties of the composite materials and also to reduce the production cost by replacing expensive resins with inexpensive solid particles. As reported by Charles (2005), the miniaturization in the electronics industry and the evolution of packaging from bulk packaging to thin film packaging takes place in line with Moore's law.

According to ASTM D882-02, the material is considered as a thin film when the thickness is not greater than 0.25 mm. Polymer thin films have numerous applications such as multicolour photographic printing, paints, adhesives, index-

matched optical coatings and photoresists (Ade et al., 1998). Currently, thin film composites composed of polymers as matrix and ceramics as reinforcement are being developed in order to improve the electrical performance and reduce assembly cost as compared to traditional discrete capacitor technology (Rao and Wong, 2004). The ceramic fillers and epoxy resin that been used in polymer thin film composites are explained in the following sub-topics.

2.4.1 Fillers

Fillers often describe as a variety of solid particulate materials such as inorganic or organic that may be irregular, acicular, fibrous or plate-like in shape and which are used in reasonably large volume loadings in plastics. Pigments and elastomeric matrices are not normally included in this definition. Moreover, fillers were considered as an additives due to its unfavorable geometrical features, surface area or surface chemical composition which might increase the modulus of the polymer, whereas tensile strength and elongation at break will remain unchanged or decreased. Besides that, addition of fillers into matrix system can reduce the cost of materials by replacing the more expensive polymer, increased dielectric properties due to giant dielectric constant possessed by the filler and increased thermal conductivity due to faster molding cycles (Xanthos, 2005).

2.4.1.1 Calcium Copper Titanate

Calcium Copper Titanate, $\text{CaCu}_3\text{Ti}_4\text{O}_{12}$ (CCTO) is a family member of $\text{ACu}_3\text{Ti}_4\text{O}_{12}$ that was first discovered by Deschanvres et al. (1967). CCTO has a body-centered cubic, *bcc* structure with a lattice parameter of 0.7391 nm at room

temperature (Prakash & Varma, 2007), with four $ATiO_3$ perovskite-type structures per unit cell (He et al., 2002) as shown in Figure 2.5.

Unlike other ferroelectric materials such as $BaTiO_3$ which displays a peak in its dielectric properties near the curie temperature, T_c , the dielectric constant of CCTO is almost constant over a wide range of temperature from 100 to 400 K (Ramirez et al., 2000). Due to its unusual dielectric property which exhibits large dielectric constant ($\sim 10^5$) and low dielectric loss at room temperature, lead free and also environment friendly, CCTO has attracted a great attention by many researchers (Subramanian et al., 2000; Homes et al., 2001).

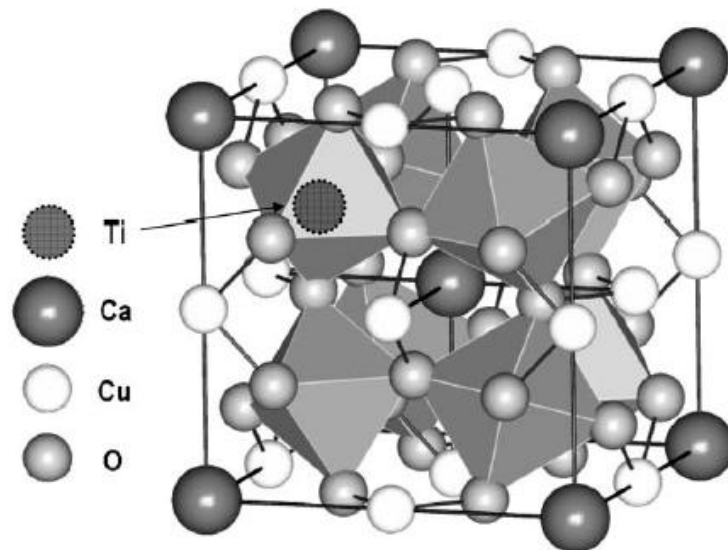

Figure 2.5: Structure of CCTO (Manik and Pradhan, 2006)

2.4.1.2 Barium Titanate

Barium Titanate, $BaTiO_3$ is a very well known dielectric material as compared to $CaCu_3Ti_4O_{12}$ because it has been widely used since the early part of the Second World War (Haertling, 1999). $BaTiO_3$ is a ferroelectric material that has

perovskite structure, with the chemical formula ABO_3 , as illustrated in Figure 2.6 (Vijatovic et al., 2008).

Ferroelectric $BaTiO_3$ has a Curie temperature, T_c of $120\text{ }^\circ\text{C}$, possesses a high dielectric constant at room temperature which is about ~ 1000 and low dielectric loss (Duran et al., 2002). Due to its good characteristics, $BaTiO_3$ has become one of the most important ferroelectric ceramics and widely used in numerous applications such as capacitors and multilayer capacitors (MLCs). Meanwhile doped $BaTiO_3$ has been used in semiconductors, PTC thermistors and piezoelectric devices.

However, one of the crucial challenges with $BaTiO_3$ is the way to reduce the change in the dielectric constant around the T_c while increasing the mean dielectric constant at temperatures far from the T_c . Weber et al. (2001), Benlahrache et al. (2004) and Lin et al. (2004) found that adding dopants such as La helps to reduce these problems.

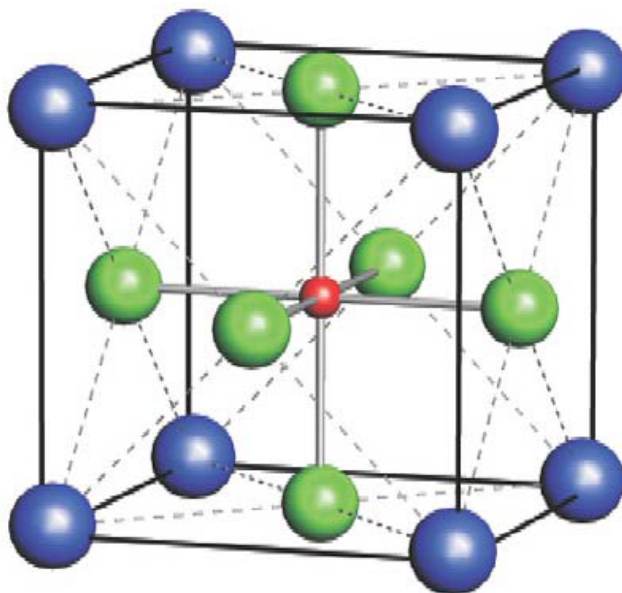

Figure 2.6: Structure of $BaTiO_3$ (Vijatovic et al., 2008)

2.4.1.3 Mica

Mica is a dielectric material that is widely used in electronics industry as mica capacitors and in electrical industry as an insulator. The most common type of mica is muscovite and phlogopite. Mica consists of 37 minerals, known as phyllosilicates which have a layered or platy texture (Carter and Norto, 2013). Mica possesses a combination of chemical, physical, electrical, thermal, and mechanical properties that are not found in any other materials.

Thermally, mica possesses excellent stability, fire proof and can resist temperature in the range of 600 – 900 °C. Chemically, they are exceptionally stable and are described as being virtually inert to various solvents, alkalies and acids except strong hydrofluoric and concentrated sulphuric acids. Electrically, they exhibit high dielectric strength, uniform dielectric constant in the range between 3 – 6, low power loss (high Q factor) and high electrical resistivity. Mechanically, micas are relatively flexible but maintain a robust strength within the film plane (Hepburn et al., 2000).

2.4.1.4 Glass-Ceramic Materials

Glass–ceramic materials are made as a glass, printed and the crystallized during the firing process. The crystalline phase that forms is dispersed uniformly throughout the glassy matrix so that the resultant material has very uniform properties. There are few major advantages of glass-ceramic materials such as higher softening point than the parent glass, stable under multiple refirings as long as it is not fired higher than the original processing temperature and the glass-ceramics

crossovers have less tendency to form pinholes, thus minimizing short circuits (Doane and Franzon, 1993).

Glass-ceramic materials are normally electrical insulators with high resistivity, low dielectric constant which is about <10 and low loss factors (Holand and Beall, 2012). Titanates and niobates based glass-ceramic materials are the most studied materials. As an important titanates based system, (Ba, Sr)TiO₃ based glass-ceramics can exhibit high dielectric constant and high breakdown strength through the addition of the other oxide and fluoride components and the adjustment of Ba/Sr and Ba/Ti ratios. Gorzkowski et al. (2007) and Han et al. (2012) reported that high dielectric constant of ~ 1000 and high breakdown strength of 80 kV/mm but low energy density of 0.3 – 0.9 J/cm³ can be found in (Ba, Sr)TiO₃ based glass-ceramics.

2.4.2 Hybrid Fillers

The incorporation of two or more types of inorganic fillers into a single polymeric system has led to the development of hybrid composites. Growth of hybrid systems have been particularly rapid in the last decade due to the demand for high-performance engineering materials, especially where low weight is one of the main requirements. There are several advantages of incorporating hybrid fillers at different compositions into the matrix systems such as diluting a more expensive reinforcement of filler with cheaper materials, facilitating the design of materials with special characteristics and improving properties of the composites (Leong et al., 2004).

Although individual classes of fillers can contribute to some desirable properties, the main concern in composites is in optimizing the different