UNIVERSITI SAINS MALAYSIA

First Semester Examination
Academic Session 2004/2005

October 2004

EBS 417E/3 - Geomechanics
[Geomekanik]

Duration: 3 hours
[Masa: 3 jam]

Please check that this examination paper consists of FIFTEEN pages of printed material and TWO pages APPENDIX before you begin the examination.

[Sila pastikan bahawa kertas peperiksaan ini mengandungi LIMA BELAS muka surat bercetak dan DUA muka surat LAMPIRAN sebelum anda memulakan peperiksaan].

This paper contains EIGHT questions. TWO questions in Section A and SIX questions in Section B.

[Kertas soalan ini mengandungi LAPAN soalan. DUA soalan dalam Bahagian A dan ENAM soalan dalam Bahagian B].

Instructions: Answer FIVE (5) questions. Answer TWO questions from Section A and any THREE questions from Section B. If a candidate answer more than five questions, only the first five answered will be examined and awarded marks.

Arahan: Jawab LIMA soalan. Jawab DUA soalan daripada Bahagian A dan mana-mana TIGA soalan daripada Bahagian B. Jika calon menjawab lebih daripada lima soalan hanya lima soalan pertama mengikut susunan dalam skrip jawapan akan diberi markah].

Answer to any question must start on a new page.

[Mulakan jawapan anda untuk setiap soalan pada muka surat yang baru].

All questions must be answered in English. However, TWO questions can be answered in bahasa Malaysia.

[Semua soalan mesti dijawab dalam bahasa Inggeris. Walau bagaimanapun, DUA soalan dibenarkan dijawab dalam bahasa Malaysia].

SECTION A

(There are two questions in this section and attempt both)

BAHAGIAN A

(Bahagian ini terdiri daripada dua soalan dan jawab kedua-duanya)

1. [a] Briefly describe the Unified Soil Classification System (USCS) (5 marks)

[b] Define the following

- (i) Well graded
- (ii) Uniformly graded
- (iii) Gap graded soil
- (iv) C_u (coefficient of uniformity)
- (v) C_c (coefficient of curvature)

(5 marks)

[c] A type of soil exhibit a void ratio (e) of 0.95, a degree of saturation (s) of 37% and particle specific gravity (G_s) of 2.72.

- (i) Determine its water content (w), porosity (n), dry unit weight (γ_d) and unit weight (γ_t).
- (ii) Compute the amount of water to be added for every cubic meter of soil in order to increase the soil to fully saturated state. Indicate saturated water content and saturated unit weight. (Take γ_w as 10 kN/m³).

(10 marks)

1. [a] *Terangkan dengan ringkas USCS (Universal Soil Classification System).* (5 markah)

[b] *Definisikan yang berikut :*

- (i) *bergred rapi*
- (ii) *bergred seragam*

- (iii) *bergred sela*
- (iv) C_u (*pekali keseragaman*)
- (v) C_c (*pekali kelengkungan*)

(5 markah)

[c] *Sejenis tanah mempamerkan nisbah keliangan (e) sebanyak 0.95, tahap ketepuan (S) 37% dan graviti tentu partikel (G_s) 2.72.*

- (i) *Tentukan kandungan air (w), keporosan (n), berat unit kering (γ_d) dan berat unit (γ).*
- (ii) *Kirakan jumlah air yang perlu ditambah untuk setiap meter padu tanah untuk menjadikan tanah kepada tahap ketepuan penuh. Nyatakan kandungan air pada tahap tepu dan berat unit tepu. (Ambil γ_w sebagai 10 kN/m^3).*

(10 markah)

2. Answer all objective questions as the following by writing the appropriate alphabet corresponding to the correct answer in your answer script.

Jawap semua soalan objektif seperti berikut dengan hanya menulis huruf yang sesuai dengan jawapan yang betul di dalam skrip jawapan.

- i. What is natural stresses in rock?
 - A. Stresses found naturally in rock.
 - B. Rock stresses as measured by an instrument.
 - C. Stresses found in rock and the overburden.
 - D. Stresses found in rock before excavation.
 - ii. Induced stresses in rock are
- i. Apakah tegasan semulajadi di dalam batuan?
 - A. Tegasan yang didapati secara semulajadi di dalam batuan.
 - B. Tegasan batuan seperti yang telah diukur oleh suatu alat.
 - C. Tegasan yang didapati di dalam batuan dan tanah beban.
 - D. Tegasan yang didapati di dalam batuan sebelum pengorekan.
 - ii. Tegasan aruhan di dalam batuan adalah
- A. akibat pertukaran tegasan oleh pengorekan yang dibuat oleh manusia.
 - B. tegasan batuan yang diukur daripada satu peralatan.

...A/-

- C. the virgin stresses found in rock and the overburden.
 - D. stresses found in rock before excavation.
- iii. Natural stresses comprised of
- I. gravitational stresses
 - II. tectonic stresses
 - III. residual stresses
 - IV. thermal stress
- A. All of the above
 - B. I and II
 - C. I, II and III
 - D. I only
- iv. The average specific gravity of the rock of an area is found to be as 2.67. What is the vertical stress component of the rock at a depth of 900 metres?
- A. 2403 kg/m²
 - B. 23573 N/m²
 - C. 23.57 MPa
 - D. 2403 kN/m²
- C. *tegasan dara yang didapati dalam batuan dan tanah beban.*
- D. *tegasan yang didapati dalam batuan sebelum pengorekan.*
- iii. *Tegasan asli terdiri daripada*
- I. *tegasan graviti*
 - II. *tegasan tektonik*
 - III. *tegasan baki*
 - IV. *tegasan haba*
- A. *Semua diatas*
 - B. *I dan II*
 - C. *I, II dan III*
 - D. *I sahaja*
- iv. *Graviti tentu purata bagi batuan di suatu kawasan di dapati 2.67. Apakah komponen tegasan menegak pada kedalaman 900 meter?*
- A. *2403 kg/m²*
 - B. *23573 N/m²*
 - C. *23.57 MPa*
 - D. *2403 KN/m²*

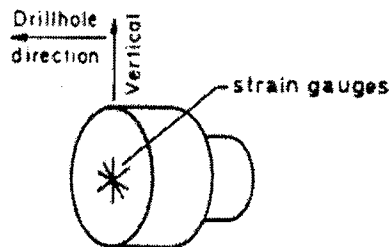

Figure 1 : the door stopper
Rajah 1: "door stopper"

- v. Figure 1 is one of the instrument used for the determination of ground stresses in rock. What method is this instrument being used for?
- A. Hydraulic fracturing
 - B. Overcoring
 - C. Drill stem testing
 - D. Stresses compensation
- v. *Rajah 1 ialah salah satu daripada peralatan yang digunakan untuk menentukan tegasan dalam batuan. Kaedah apakah peralatan ini digunakan?*
- A. *Rekahan hidraulik*
 - B. *Peneras-lebihan*
 - C. *Ujian batang gerudi*
 - D. *Penebusgantikan tegasan*

vi The factor k in the rock stress components is

- A. σ_v/σ_h
- B. $1/\sigma_v$
- C. $1/\sigma_h$
- D. σ_h/σ_v

vi Faktor k dalam komponen tegasan batuan ialah

- A. σ_v/σ_h
- B. $1/\sigma_v$
- C. $1/\sigma_h$
- D. σ_h/σ_v

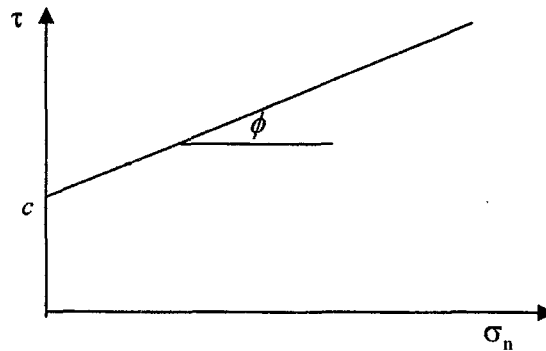

Figure 2
Rajah 2

vii Mohr's Coulomb formula is expressed as in Figure 2 that gives a relationship of

- A. $\tau = c + \sigma_n \tan \phi$
- B. $c = \tau + \sigma_n \tan \phi$
- C. $\sigma_n = c + \tau \tan \phi$
- D. $\phi = c + \sigma_n \tan \tau$

vii. Formula Mohr Coulomb dinyatakan seperti di dalam Rajah 2 yang memberikan hubungan

- A. $\tau = c + \sigma_n \tan \phi$
- B. $c = \tau + \sigma_n \tan \phi$
- C. $\sigma_n = c + \tau \tan \phi$
- D. $\phi = c + \sigma_n \tan \tau$

viii Hoek Brown Criterion for rock failures is expressed as

$$\sigma_1 = \sigma_3 + \sqrt{m\sigma_c\sigma_3 + s\sigma_c^2}$$

What is "s" stands for in the formula?

- A. minimum stress applied to specimen.
- B. Maximum stress applied to specimen.
- C. Uniaxial compressive strength.
- D. Degree of fracturization of sample and tensile strength.

viii Kriteria Hoek Brown untuk kegagalan batuan dinyatakan seperti

$$\sigma_1 = \sigma_3 + \sqrt{m\sigma_c\sigma_3 + s\sigma_c^2}$$

Apakah "s" di dalam formula tersebut?

- A. Tegasan minimum yang dikenakan ke atas sampel.
- B. Tegasan maksimum yang dikenakan ke atas sampel.
- C. Kekuatan mampatan unipaksi.
- D. Tahap keretakan dalam sampel dan kekuatan tegangan.

- | | |
|--|---|
| ix. The roof of a tunnel is subjected to stresses in | ix. <i>Bumbung terowong mengalami tegasan dalam</i> |
| A. tension | <i>A. tegangan</i> |
| B. compression | <i>B. mampatan</i> |
| C. virgin ground | <i>C. kawasan dara</i> |
| D. tangent to the tunnel face. | <i>D. keadaan tangent kepada muka terowong</i> |
| x The wall of a tunnel is subjected to stresses in | x.. <i>Dinding terowong mengalami tegasan dalam</i> |
| A. tension | <i>A. tegangan</i> |
| B. compression | <i>B. mampatan</i> |
| C. virgin ground | <i>C. kawasan dara</i> |
| D. tangent to the tunnel face. | <i>D. keadaan tangent kepada muka terowong</i> |

(20 marks)

(20 markah)

SECTION B

(There are six questions and attempt any three of them)

BAHAGIAN B

(Terdapat 6 soalan dan jawab tiga daripadanya)

3. A soil deposit consist of saturated organic silt with an average unit weight of 15.2 kN/m³. The ground water table is at 1 m below the ground surface. (Take γ_w as 9.81 kN/m³),
- (a) Compute initial vertical stress (total and effective) at 10 m depth.
- (3 marks)
- (b) A fill consisting of saturated sand with G_s of 2.70 and void ratio (e) of 0.6366 is spread hydraulically 4 m thick on top of the organic silt. Compute the new vertical stresses at the same depth as (a) considering the water table will rise to the fill surface.
- (7 marks)
- (c) The saturated sand fill drains until the water table reverts to original surface. The sand still retains 28% saturation. Find the new vertical stresses at the same depth.

(7 marks)

- (d) State your observations on the outcome of sand drainage. (3 marks)
3. Tanah yang mengandungi lodak berorganik dengan berat unit purata 15.2 kN/m^3 . Aras air bumi berada pada paras 1 m di bawah permukaan. Ambil γ_w sebagai 9.81 kN/m^3 .
- (a) Kirakan tegasan tegak awal (keseluruhan dan efektif) pada kedalaman 10 m. (3 markah)
- (b) Pasir tepu dengan G_s sebanyak 2.70 dan nisbah keliangan (e) 0.6366 ditambah secara hidraulik sehingga ketinggian 4 m di atas lodak berorganik asal. Kirakan tegasan tegak baru (keseluruhan dan efektif) pada kedalaman seperti di (a). Pertimbangkan aras air akan naik ke permukaan kerana pasir ditambah secara hidraulik. (7 markah)
- (c) Air disalurkan keluar sehingga paras air bumi berada pada tahap asal. Pasir masih lagi dalam keadaan 28% ketepuan. Kirakan tegasan tegak terkini pada kedalaman yang sama. (7 markah)
- (d) Nyatakan pemerhatian anda mengenai kesan penyaliran ke atas tegasan keseluruhan dan efektif. (3 markah)
4. [a] With the aid of a Mohr's diagram, differentiate between active and passive earth pressure for cohesionless soil. (4 marks)
- [b] A 6 m high retaining wall was built to retain cohesionless sand with the following characteristics

G_s (specific gravity) = 2.85

e (void ratio) = 0.85

ϕ (angle of internal friction) = 34°

(i) Compute active earth pressure acting on the wall if ground water table is at a depth of 2 m.

(6 marks)

(ii) Determine the reductions in overturning moments if a drainage hole were constructed at the base of the retaining wall. (Take γ_w as 10 kN/m^3)

(10 marks)

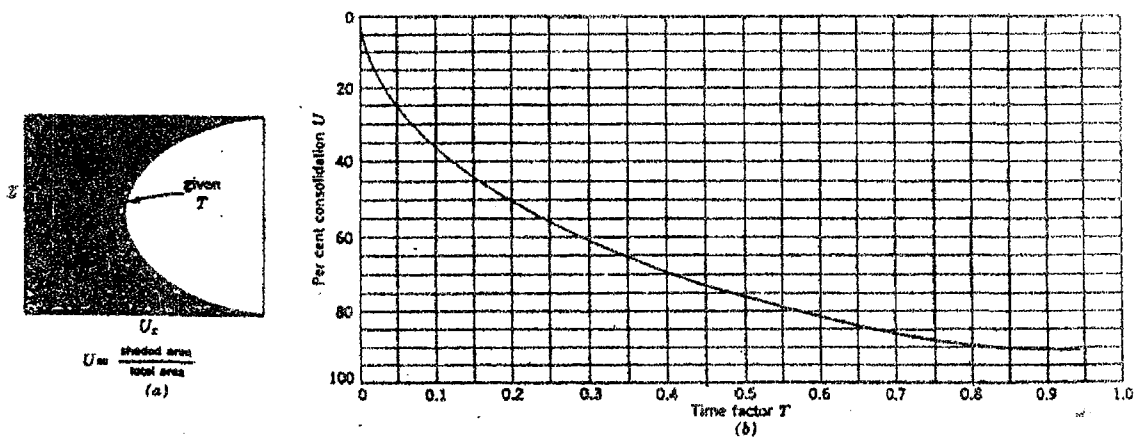

Figure 3

Rajah 3

4. [a] Dengan bantuan gambarajah Mohr, bezakan di antara tekanan bumi aktif dan pasif untuk tanah tak berjelekit.

(4 markah)

[b] Tembok penahan setinggi 6 m dibina untuk menampung pasir tak jeleket dengan ciri-ciri berikut :

$G_s = 2.85$

$e = 0.85$

$\phi = 34^\circ$

(i) *Kirakan tekanan mendatar ke atas tembok penahan sekiranya paras air berada 2 m di bawah permukaan.*

(6 markah)

(ii) *Tentukan pengurangan momen terbalikan jika lubang saluran air dibuat pada dasar tembok penahan.*

(10 markah)

5. [a] A clay layer 5 m thick is subjected to a uniform increase in pressure that will eventually lead to a settlement of the surface of 240 mm. The coefficient of consolidation of the clay is $0.6 \text{ m}^2/\text{year}$ and the layer is over and underlain by permeable sand. Estimate the period for the following settlement to occur.

(i) 24 mm

(ii) 120 mm

(10 marks)

[b] Determine the increments in vertical, horizontal and shear stress at depths of 1 m, 2 m and 4 m below centerline of a strip footing 2 m wide that carries a load of 200 kN/m run.

(10 marks)

5. [a] *Lapisan tanah lempung setebal 5 m dikenakan tekanan sekata yang akan menyebabkan mendapan permukaan sebanyak 240 mm. Pekali pengukuhan tanah lempung ialah $0.6 \text{ m}^2/\text{tahun}$. Lapisan lempung mempunyai pasir dengan kebolehtelapan yang tinggi di atas dan di bawahnya. Anggarkan jangkamasa untuk mendapan.*

(i) 24 mm

(ii) 120 mm

(10 markah)

[b] Tentukan penambahan tegasan menegak, mendatar dan ricih pada kedalaman 1 m, 2 m dan 4 m di bawah garis tengah tapak jalur dengan kelebaran 2 m dan membawa beban 200 kN/m.

(10 markah)

6. (a) Describe briefly the failure criterion used in rocks.

(4 marks)

(b) Plot the poles of the following discontinuities:

- (i) dip 10° towards 030°
- (ii) dip 20° towards 035°
- (iii) dip 21° towards 032°
- (iv) dip 15° towards 031°
- (v) dip 14° towards 032°

Estimate the general dip and trend of these structures?

(6 marks)

(c) A road cut is going to cut through a granite hill. The rock slope of the road is going to dip towards 300° . The rock has two sets of joint as follow:

- Set 1 dips 52° towards 258°
- Set 2 dips 60° towards 333°

The angles of the road cut is being considered at the following angles:

- (i) 60°
- (ii) 52°
- (iii) 40°

Give your comments on the type of failures (if any) that may occur on each proposed slope.

What is the most steepest slope that you would recommend and why?

Attach all tracing papers used with your answers.

(10 marks)

6 (a) *Terangkan dengan ringkas criteria kegagalan dalam batuan.*

(4 markah)

(b) *Plot kutub-kutub ketakselajaran berikut:*

(i) *miring 10° ke arah 030°*

(ii) *miring 20° ke arah 035°*

(iii) *miring 21° ke arah 032°*

(iv) *miring 15° ke arah 031°*

(iv) *miring 14° ke arah 032°*

Anggarkan kemiringan am dan tren struktur-struktur ini?

(6 markah)

(c) *Sebuah jalan raya akan dibina dan akan memotong sebahagian daripada sebuah bukit granit. Cerun di tepi jalan raya ini miring ke arah 300° . Batuan yang akan dipotong ini terdapat dua set kekar iaitu:*

Set 1 *miring 52° ke arah 258°*

Set 2 *miring 60° ke arah 333°*

Sudut muka cerun potongan ini sedang dipertimbangkan seperti berikut:

(i) 60°

(ii) 52°

(iii) 40°

Beri komen anda mengenai jenis kegagalan (jika ada) yang mungkin terjadi pada setiap sudut muka cerun yang dicadangkan.

Apakah sudut muka cerun yang paling curam yang anda syorkan dan nyatakan mengapa? Jawapan anda hendaklah disertakan dengan kertas surih yang anda gunakan.

(10 markah)

7. (a) Discuss the principle and the advantages of using shotcrete as one of the method in mine support. (7 marks)
- (b) Explain briefly how do rock bolts act as a roof support in tunnels. (6 marks)
- (c) A tunnel of 3 m wide is to be driven in a granitic rock mass. The tunnel is oriented such that the dominant joint set strikes perpendicular to the tunnel axis with a dip of 30° against the drive direction. Classify the rock mass using the information in Table 1 below and the CSIR Geomechanics Classification of Jointed Rock Masses as enclosed in Appendix 1.

Table 1

Classification parameters	Value or description
1. Strength of intact material	150 MPa
2. RQD	70%
3. Joint Spacing	0.5 m
4. Conditions of joints	Slightly rough surfaces. Separation <1mm Hard joint wall rock
5. Ground water	Water under moderate pressure

(7 marks)

7. (a) *Bincangkan prinsip dan kebaikan penggunaan syotkrit sebagai satu kaedah sokongan di lombong* (7 markah)
- (b) *Terangkan dengan ringkas bagaimana bolt batuan bertindak sebagai sokongan bumbung di dalam terowong.* (6 markah)

- (c) Sebuah terowong 3 m lebar akan ditebuk di dalam jisim batuan granit. Terowong ini dibuat dengan suatu arah supaya jurus bagi satu set kekar yang dominan berkeadaan serenjang dengan paksi terowong. Set kekar ini berkemiringan 30° melawan arah terowong dikorek. Kelaskan jisim batuan ini dengan menggunakan maklumat seperti di Jadual 1 dan "CSIR Geomechanics Classification of Jointed Rock Masses" seperti yang disertakan di Lampiran 1.

Jadual 1

Parameter Pengelasan	Nilai atau penerangan
1. Kekuatan bahan utuh	150 MPa
2. RQD	70%
3. Jarak kekar	0.5 m
4. Keadaan kekar	Permukaan kasar sedikit Bukaan kekar <1mm Dinding batuan kekar keras
5. Air bumi	Air berkeadaan tekanan sederhana

(7 markah)

8. A slope is being analysed for its stability. Its geometry is in Figure 4. The slope is inclined at 50° and the discontinuity is inclined at 30° daylighting the slope. The height of the slope is 25 m and the discontinuity is seen on the slope at 21.5 m from the top of the slope. The parameters of the slope materials are in Table 2.

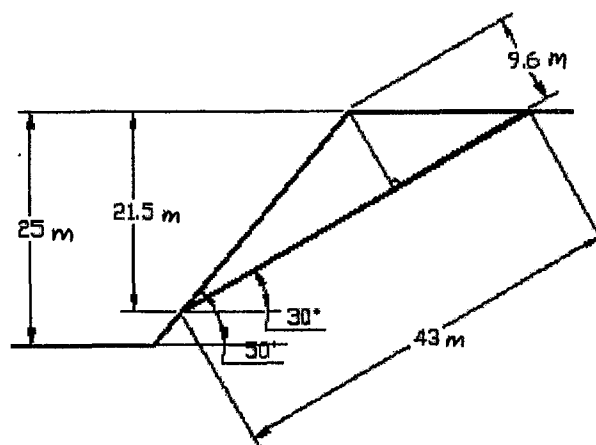

Figure 4

Table 2

Parameters for the slope material	Mean values	Standard deviation
Unit weight	25 kN/m ³	1.7 kN/m ³
Cohesion	40 kN/m ²	14 kN/m ²
Friction angle	25 ^o	2 ^o

- i) What is the safety factor using deterministic method? (6 marks)
- ii) Assuming that all parameters are normally distributed, the z values obtained from random numbers for a number of trials are as in Table 3. Calculate the probability of failure based on the number of trials in the table? Do the number of trials sufficient to obtain a reasonably non-biased answer? What do you recommend?

Table 3

trial	z values		
	Unit weight	cohesion	Friction angle
1	-0.84	0	-0.26
2	-0.25	-0.52	0.77
3	0	-0.52	1.28
4	-1.28	-2.33	-1.28

(14 marks)

8. Suatu cerun sedang dianalisa mengenai kestabilannya. Bentuk cerun ini seperti di Rajah 4. Cerun ini condong pada 50^o dan ketakselajaran di dalam cerun ini condong pada 30^o dan boleh dilihat di muka cerun. Ketinggian cerun ini 25 m dan ketakselajaran ini boleh dilihat di muka cerun pada 21.5 m daripada bahagian atas cerun. Parameter-parameter bagi bahan dalam cerun adalah seperti di Jadual 2.

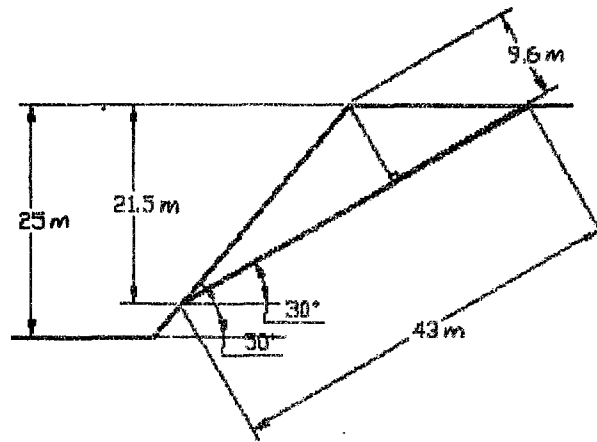

Rajah 4

Jadual 2

Parameter bahan cerun	Nilai min	Sisihan piawai
Berat unit	25 kN/m ³	1.7 kN/m ³
Kejeleketan	40 kN/m ²	14 kN/m ²
Sudut geseran	25 ^o	2 ^o

- i) Apakah faktor keselamatan pada nilai dengan menggunakan kaedah berketentuan? (6 markah)
- ii) Dengan andaian semua parameter bertaburan normal, nilai-nilai z yang telah diperolehi daripada nombor-nombor rawak bagi beberapa cubaan seperti di Jadual 3. Kirakan kebarangkalian kegagalan cerun in berdasarkan kepada bilangan cubaan di dalam jadual ini. Adakah bilangan cubaan ini memadai untuk memperolehi jawapan yang tidak berat sebelah? Apakah pengesyoran anda?

Jadual 3

set	Nilai-nilai z		
	berat unit	kejeleketan	Sudut geseran
1	-0.84	0	-0.26
2	-0.25	-0.52	0.77
3	0	-0.52	1.28
4	-1.28	-2.33	-1.28

(14 markah)

ooOoo

Appendix 1
Lampiran 1

CSIR Geomechanics Classification of Jointed Rock Masses

A. CLASSIFICATION PARAMETERS AND THEIR RATINGS

PARAMETER		RANGES OF VALUES							
1	Strength of intact rock material	Point load strength index	> 8 MPa	4-8 MPa	2-4 MPa	1-2 MPa	For this low range - uniaxial compressive test is preferred		
		Uniaxial compressive strength	> 200 MPa	100-200 MPa	50-100 MPa	25-50 MPa	10-25 MPa	3-10 MPa	1-3 MPa
	Rating	15	12	7	4	2	1	0	
2	Drill core quality RQD	90%-100%	75%-90%	50%-75%	25%-50%	< 25%			
	Rating	20	17	13	8	3			
3	Spacing of joints	>3m	1-3m	0.3-1m	50-300 mm	< 50 mm			
	Rating	30	25	20	10	5			
4	Condition of joints	Very rough surfaces Not continuous No separation Hard joint wall rock	Slightly rough surfaces Separation <1 mm Hard joint wall rock	Slightly rough surfaces Separation <1 mm Soft joint wall rock	Slickensided surfaces or Gauge <5 mm thick or Joints open 1-5mm Continuous joints	Soft gauge >5mm thick or Joints open >5mm Continuous joints			
	Rating	25	20	12	6	0			
5	Ground water	Inflow per 10m tunnel length	None		< 25 litres/min.	25-125 litres/min.	> 125 litres/min.		
		Ratio $\frac{\text{joint water pressure}}{\text{major principal stress}}$	0		0.0-0.2	0.2-0.5	> 0.5		
		General conditions	Completely dry		Moist only (interstitial water)	Water under moderate pressure	Severe water problems		
	Rating	10		7	4	0			

B. RATING ADJUSTMENT FOR JOINT ORIENTATIONS

Strike and dip orientations of joints		Very favourable	Favourable	Fair	Unfavourable	Very unfavourable
Ratings	Tunnels	0	-2	-5	-10	-12
	Foundations	0	-2	-7	-15	-25
	Slopes	0	-5	-25	-50	-60

C. ROCK MASS CLASSES DETERMINED FROM TOTAL RATINGS

Rating	100-81	80-61	60-41	40-21	< 20
Class No.	I	II	III	IV	V
Description	Very good rock	Good rock	Fair rock	Poor rock	Very poor rock

D. MEANING OF ROCK MASS CLASSES

Class No.	I	II	III	IV	V
Average stand-up time	10 years for 5m span	6 months for 4 m span	1 week for 3 m span	5 hours for 1.5 m span	10 min. for 0.5m span
Cohesion of the rock mass	> 300 kPa	200-300 kPa	150-200 kPa	100-150 kPa	< 100 kPa
Friction angle of the rock mass	> 45°	40°-45°	35°-40°	30°-35°	< 30°

TABLE 6 - THE EFFECT OF JOINT STRIKE AND DIP ORIENTATIONS IN TUNNELLING

Strike perpendicular to tunnel axis				Strike parallel to tunnel axis		Dip 0°-20° irrespective of strike
Drive with dip		Drive against dip		Dip 45°-90°	Dip 20°-45°	
Dip 45°-90°	Dip 20°-45°	Dip 45°-90°	Dip 20°-45°			
Very favourable	Favourable	Fair	Unfavourable	Very unfavourable	Fair	Unfavourable

Appendix 2

Lampiran 2

Stereonet

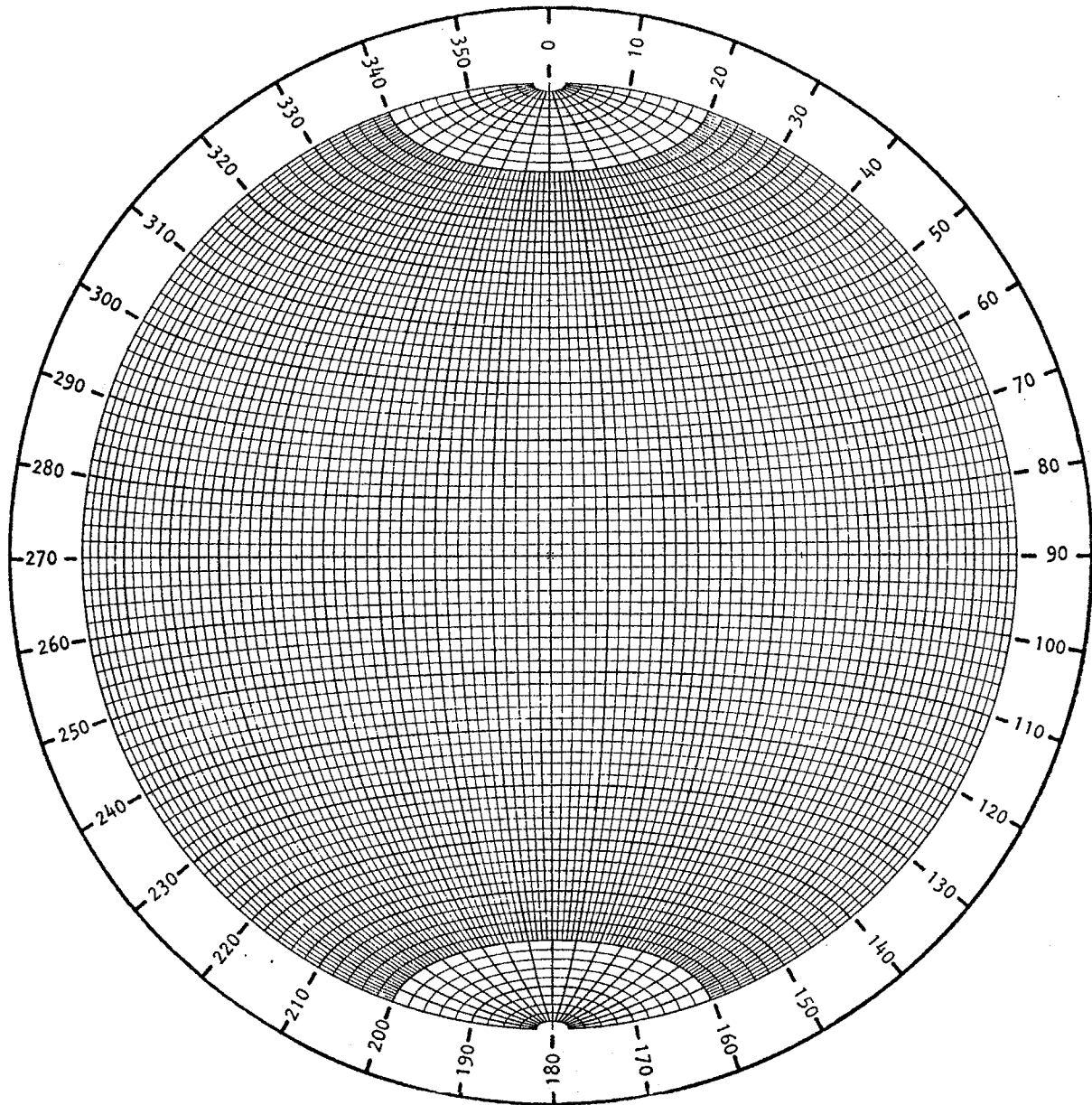

Equatorial equal-area stereonet marked in 2° intervals.

*Computer drawn by Dr. C.M. St John of the Royal School of Mines,
Imperial College, London.*