

# Stock price and Foreign Exchange Rate in Malaysian Context

Sharmila Thinagar

School of Economics, Faculty of Economics and Management, National University of  
Malaysia (UKM), 43600 Bangi, Selangor, Malaysia

Email: vanessa91\_sham@yahoo.com

## Abstract

This study investigates the correlation and causality direction between FTSE Bursa Malaysia Kuala Lumpur Composite Index and five foreign exchange rates namely United States Dollar (USD), Great Britain Pounds (GBP), Euro Dollar (EURO), Singapore Dollar (SGD) and Thailand Bhat (THAI) using a standard time series method. Using a monthly data spanning from January 1994 until December 2014. The empirical findings shows that the stock return granger cause the return of exchange rate. Thus, it can be concluded that there is a unidirectional causality between stock market and exchange rate and it is supportive of “portfolio balances” model. This study implied that the stability of the exchange rate is depend on the stability of the stock price, and therefore the policy makers need to observe precisely the movement of stock market and exchange rate.

**Keywords:** *Stock market, foreign exchange rates and portfolio balances model*

## 1. Introduction

In a country like Malaysia, where the country’s economy are still emerging and the capital markets are still in the vulnerable condition, there are very few studies that have been made to investigate the relationship between the stock prices and exchange rates and the results found are contradicting which encourages us to conduct the study to detect the relationship between the variables. Prior to our knowledge, the stock market and exchange rates plays a crucial role in facilitating the economy activity. That’s the reason why the interaction between stock price and exchange rate has been the subject of many academic debate and empirical analysis.

To well explain the contribution and motivation of this study, the issue can be closely related to our Malaysian context. The current situation of Malaysian economy can be similarly explained by looking back into the financial crisis that happened in the year 1997. From July 1997, Malaysia had attracted more abroad investor’s attention but not for its extraordinary economy performance but for its entanglement in a major Asian crisis. At that particular time, the ringgit Malaysia fell from an average of 2.42 to the US Dollar in April 1997 to 4.88 to the US Dollar in January 1998. That’s when the policy makers take in charge by formulation two distinctive phases, the first one is being centered on tight fiscal and monetary policies, and the second one is based on the expansionary policies. Thus, currently we are experiencing a similar

currency depreciation as the Malaysian ringgit fell from an average of 3.17 to the US Dollar in August 2014 to 4.32 to the US Dollar in 6<sup>th</sup> October 2015.

That's the reason what motivated us to conduct this study because understanding the relationship between the exchange rates and stock prices are very important from the point of view of the policy makers in this changing global environment. Currency is often included as an asset in the portfolio held by the mutual fund, hedge funds and other professionals who managed portfolios, and the knowledge of the relationship between exchange rate and stock prices may enable to manage the risk efficiently (Ariff and Syarisa, 1999).

Thus, according to the classical economic theory, the interaction between the stock price and exchange rate can be divided into two approaches which is the "flow-oriented" model and "portfolio balances model".

The first model is the "flow-oriented" model. Based on this approach, they postulates that the exchange rate movements causes movements in stock price. This model's approach was built based on the macroeconomic view that because stock price represent the discounted present value of a firm's expected future cash flow, thus any incident that affects the firm's cash will be reflected in that firm's stock price if the market is efficient as suggested in the Efficient Market Hypothesis.

Second approach is the portfolio balance approaches or known as "stock-oriented" model which was developed by Branson 1977, this approach theorizes the opposite of the "flow-oriented" model which suggest that the movement in the stock prices can cause changes in the exchange rate movement via the capital account transaction. For an instance, the process of buying or selling of the domestic securities in foreign currency in response to domestic stock market movement has a flow through effect into the currency market.

However, the interaction between the two variables which is the stock prices and exchange rates has preoccupied the minds of the economists, regulators and policy makers since they both play important roles in influencing the development of a country's economy. The factors that influence the behavior of stock indices and exchange rate has attracted the attention of the economists, policy makers and the investment community for a long period of time.

Some of the factors which influence the daily stock prices of a country are enterprise performances, dividends, and equity prices of other countries, gross domestic product, exchange rate, interest rate, current account, money supply, employment rate, and other related information (Kurihara, 2006). In contrast, the exchange rate has become one of the main contributing factor in the business profitability and equity prices due to the continuing rise in the world trade and capital movement.

Conversely, in examining the relationship between the stock price and foreign exchange rates, we will definitely provoked with the question whether the changes in exchange rate affect the stock price or vice versa. Therefore, we have approached this question by using the Granger Causality tests. Furthermore, we make use of the unit root test (ADF and PP) and correlation tests to establish the strength of the correlation between the stock prices and exchange rates.

The paper is organized as follows: the second section of the paper is the literature review followed by data and methodology, empirical evidences and conclusion.

## **2. Literature Review**

The relationship between the stock price and exchange rate captivates a larger amount of researchers, economists and policy makers to use both the variables as their research interest due to the current dramatic upsurges in world trade and capital movement (Bartram and Bodnar, 2012). In today's globalization era, the currency is the main determinants in the business profitability and the equity markets. That's the result why these two variables are appear to be the subject of much debate in the financial world.

Thus, looking into the theoretical framework, the framework suggest that the two main approaches which link both the variables which is the traditional approach and the portfolio approach.

The traditional approach is also known as "flow-orientated" model which suggest a Granger causality which causes exchange rate to stock prices. On the other hand, the portfolio balance model is also known as "stock-orientated" model, which causes the effect from stock price to exchange rates. Based on the previous empirical evidences, there are four types of relationship between the exchange rates and stock prices in the financial market.

The four types are unidirectional relation from exchange rates to stock price, unidirectional relation from exchange rates to stock price, bi-directional relation between exchange rate and stock price and no relation between exchange rates and stock prices. Even though, there is no specific agreement on either theoretical and empirical evidences on the relationship between exchange rates and stock price, but generally most of the research done based on this study shows that the two variables should be linked together, especially when the economy of a country suffered from a crisis period.

### **2.1 Unidirectional causality from exchange rate to stock price**

According to Chen and Chen (2012), there is abundant of empirical evidences which supported the traditional approach where the changes in the exchange rate lead to the stock price movement. A vast number of researches have been carried out to study the relationship between the exchange rate and stock price in the developed countries. For an instance, the dynamic relations between the exchange rates and stock prices for the G-7 countries namely Canada, France, Germany, Italy, Japan, the UK and the US are investigated by Nieh and Lee (2001) by using the daily data from October 1993 until February 1996. Based on the study, the researcher found that there is a short term causality which lead the exchange rate to stock prices which is only significant for one day in Germany, Canada and the UK.

Whereas, Abdalla and Murinde (1997) had examine the relationship between the exchange rates and stock prices on the emerging markets. The study was carried out based on countries namely India, Korea, Pakistan and Philippines and monthly data was used from January 1985 to July 1994. Hence, the study also revealed that there is relationship between the exchange rate and

stock prices based on the traditional approach (from exchange rate to stock price) in India, Korea and Pakistan.

## ***2.2 Unidirectional causality from stock price to exchange rate***

Ajayi et al. (1998) used the error correction model to study whether there is short run or long run relationship between the exchange rate and stock prices in 8 advanced countries by using daily data from April 1985 until July 1991. The study revealed that the stock price negatively affect the exchange rate in 8 advanced countries namely Canada, Germany, France, Italy, Japan, Netherlands, the UK and the US. Besides that the relationship between exchange rate and stock price was also being tested in the emerging markets. For an instance, Abdalla and Murinde (1997) elevated the Granger causality test between the two variables in their study and the result revealed that there is a unidirectional relation from the stock price to exchange rate in Philippines.

Furthermore, the Asian financial crisis 1997 also attracts the attention and the interest of the researchers towards the relationship of the exchange rates and stock prices in the economy. In regard to the Asian Financial Crisis issue, Hatemi-J and Roca (2005) investigated the relationship by using a new bootstrap stimulation causality tests with leveraged modifications. Thus, the finding revealed that before the Asian crisis, the exchange rate of Malaysia is found to be affected by its stock market which is in line with the portfolio approach assumption.

## ***2.3 Bi-directional causality between the exchange rate and stock price***

Besides that, it was found that there is a bi-directional relationship between the exchange rate and stock price which embraced both the traditional and portfolio balances approach in the previous studies (Inci and Lee, 2014). Hence, Bahmani and Sohrabian (1992) was the first one to expose that there can be a bi-directional causality between the exchange rate and stock price. In their study, the co-integration and Granger test are employed by using the monthly data from July 1973 to December 1988 and the result shows that there is a bi-directional relationship between the exchange rate and stock prices. Thus, the similar result was found by Ajayi and Mougoue (1996) for the developed economy countries of France, Italy, Germany, Japan, the UK and the US.

The research of this study also had been done by utilizing more advanced techniques and in emerging markets. For an example, to study the dynamic causality between the exchange rate and stock price for the Asian emerging markets, Doong, Yang and Wang (2005) employed a GARCH-M model. The study used weekly data from January 1989 until January 2003, and the result suggested that there is a bi-directional relation between the exchange rate and stock price for Indonesia, Korea, Malaysia and Thailand. Moreover, this result is aligned with the finding found by Inci and Lee (2014) for the country France, Switzerland, Germany, Canada, Japan, the UK and the US.

## ***2.4 No relationship between the stock price and exchange rate***

Although there is evidences which supports the unidirectional causality from exchange rate to stock price, unidirectional causality from stock price to exchange rate, bi-directional causality

between the exchange rate and stock price, there are also some studies which shows that there is no relationship between the exchange rate and stock prices in certain countries (Patra and Poshakwale, 2006).

This evidence can be seen from the study done by Hatemi-J and Roca (2005), where they studied about the dynamic causality during the Asian crisis period. Thus, the results found explains that the stock prices were not affected by the exchange rate or neither the exchange rate affected the movement of the stock prices for Malaysia, Indonesia, Philippines and Thailand. Furthermore, Mishra (2005) revealed that the Indian stock market doesn't have any relation with its foreign exchange rate, which in line with the Hatemi-J and Roca's argument in the same year.

In conclusion, all the previous studies shows that the relationship of the exchange rate and stock price is sensitive based on the different economy markets analyzed, the estimation techniques used and the time period of the study.

### 3. Data and Methodology

We firstly examine the time series properties of the named two variables which is the stock price and exchange rate. The Augmented Dickey Fuller (ADF) and Philip-Peron tests are employed to find out the order of the integration of both the series. If the series are found to be at I(1), then the co-integration test can be applied.

In order to examine the issue of the causation, we can either employ the error correction modeling approach or the standard Granger causality test depending upon whether there is a long run relationship between the stock price and exchange rate or not. Thus, the granger offers four definitions. The definitions are unidirectional relation from exchange rate to stock price (EX→SP), unidirectional relation from stock prices to exchange rate (SP→EX), bi-directional relations between stock prices and exchange rates (SP↔ EX), and no feedback causality between exchange rate and stock prices. If the stock prices and exchange rates are co-integrated, then the vector auto-regression model should include an error correction term which can be stated as follows:

$$y_t = \alpha_0 + \alpha_1 y_{t-1} + \dots + \alpha_1 y_{t-1} + \beta_1 x_{t-1} + \dots + \beta_1 x_{t-1} + \varepsilon$$

$$x_t = \alpha_0 + \alpha_1 x_{t-1} + \dots + \alpha_1 x_{t-1} + \beta_1 y_{t-1} + \dots + \beta_1 y_{t-1} + \varepsilon$$

This study focused on the stock price Financial Times Stock Exchange (FTSE) BURSA SAHAM Kuala Lumpur Composite Index (KLCI) and the foreign exchange rate namely United States Dollar (USD), Great Britain Pounds (GBP), EURO, Singapore Dollar (SGD), and Thailand Bhatt (THAI). The collected data is the time series data which consist of monthly closing price for both the stock price and foreign exchange rates. All the data are collected from the Data Stream for the period from January 1994 until December 2014 which is 251 observation. Thus, all the time series data are converted into the return series using the statistical software Eviews. The formulae used are calculated as below:

$$\frac{Usd - Usd(-1)}{Usd(-1)}$$

#### 4. Empirical Evidences

And the further analysis of the study is done by using four methods. Firstly, the descriptive statistics was employed in order to determine the nature of the distribution. Secondly, unit root test which is the Augmented Dicker Fuller (ADF) test and Phillip-Pheron (PP) test is used to check the stationary of the time series data whether they are integrated at I(0) or I(1). Thirdly, the correlation coefficient test was used to identify the correlation between the stock price and foreign exchange rate. Finally, the Granger Causality test was employed to capture the direction of the correlation, so that we can identify whether relation between the stock price and foreign exchange rate are supportive of “flow-oriented” or “portfolio-balances” model.

Firstly, normality test was applied on all the return series to determine the nature of their distribution. For this purpose, a descriptive statistics were computed as shown in table 1 for all the variable series. From the obtained statistics, it can be concluded that all the series are non-normally distributed as the skewness value for RKLCI, RUSD, RGBP, REURO, RSGD and RTHAI are 0.530916, 1.702368, 0.797980, 0.781487, 0.915805 and 0.444425 respectively which is more than 0 which indicate that all the series are right skewed distributed. Whereas, the kurtosis value for RKLCI, RUSD, RGBP, REURO, RSGD and RTHAI are 7.835544, 23.80678, 10.22656, 7.949053, 15.11010 and 9.936058 respectively which shows that the values of kurtosis for all the return series are more than 3 which indicate that the series are leptokurtic distribution.

Table 1: Descriptive Statistics

	RKLCI	RUSD	RGBP	REURO	RSGD	RTHAI
Mean	0.004166	0.001234	0.001507	0.001779	0.001905	0.000565
Median	0.007382	0.000000	0.000000	0.000000	0.000000	0.000000
Maximum	0.342349	0.162234	0.144231	0.133652	0.096491	0.125000
Minimum	-0.247709	-0.130435	-0.126050	-0.128421	-0.080000	-0.111111
Std. Dev.	0.068595	0.022045	0.025922	0.027795	0.015974	0.033784
Skewness	0.530916	1.702368	0.797980	0.781487	0.915805	0.444425
Kurtosis	7.835544	23.80678	10.22656	7.949053	15.11010	9.936058
Jarque-Bera	256.3335	4648.880	572.8050	281.7059	1568.847	511.4016
Probability	0.000000	0.000000	0.000000	0.000000	0.000000	0.000000
Sum	1.045595	0.309693	0.378215	0.446549	0.478033	0.141919
Sum Sq. Dev.	1.176306	0.121492	0.167986	0.193135	0.063795	0.285339
Observations	251	251	251	251	251	251

Secondly, after confirmed that all the six variables are non-normally distributed, the question of stationary of the six time series posed concern. Therefore, ADF and PP test was performed to check the stationary of the time series. The result is tabulated in the table 2 below. Based on

the table above, the result shows that the ADF and PP test shows that the values obtained falls behind the critical value at 1% significance level, thus giving a probability value of 0, which leads to the rejection of the null hypothesis of unit root for all the six time series. Hence, it is concluded that on the basis of ADF and PP test statistics that the stock price return and the five exchange rate return found to be stationary at level form. The consequence of stationary at level form in all the series, is that Johansen Co-Integration cannot be applied to the variables of the time series in order to determine the long-term relationship between them.

Table 2: Unit Root Test

	<b>ADF</b>	<b>PP</b>
	<b>LEVEL</b>	<b>LEVEL</b>
<b>RKLCI</b>	-13.76242	-13.70321
<b>RUSD</b>	-11.72170	-11.73388
<b>RGBP</b>	-11.82377	-11.92403
<b>REURO</b>	-11.72512	-11.70626
<b>RSGD</b>	-13.97728	-14.14102
<b>RTHAI</b>	-19.48474	-19.69599

Thirdly, the correlation test was conducted between the stock returns (RKLCI) and exchange rates (RUSD, RGBP, REURO, RSGD, and RTHAI). Correlation test is done to see the existence of interdependency among the time series. Based on the table 1.3, the analysis shows that the stock price negatively correlated to all the foreign exchange rates, except to the Thai exchange rate they are positively correlated. Thus, the correlation needs to be further verified for the direction of influence by Granger Causality test.

Table 3: Correlation Coefficient Test

Correlation	RKLCI	RUSD	RGBP	REURO	RSGD	RTHAI
RKLCI	1.000000					
RUSD	-0.359437	1.000000				
RGBP	-0.209936	0.663979	1.000000			
REURO	-0.197250	0.586712	0.811274	1.000000		
RSGD	-0.190239	0.778929	0.735297	0.754907	1.000000	
RTHAI	0.037789	-0.008085	0.019977	0.086740	0.139255	1.000000

Finally, to capture the direction of the correlation between the stock price and exchange rates, Granger Causality test was employed. Result in table 4 below shows that there is a unidirectional causality between the stock price return and exchange rates return among all the time series variable. Thus, the null hypothesis of stock price return does not granger cause the exchange rate is rejected. In other word, Granger Causality test shows that stock returns does granger cause the exchange rate namely RUSD, RGBP, REURO, RSGD and RTHAI. Hence, it can be concluded that there is unidirectional causality from stock price return to exchange

rates and it hypothesizes that the Malaysian economy is supportive of “portfolio balances” model.

Table 4: Granger Causality Test

Exchange rate and stock price Causality	F-Statistic	Prob.	Direction of causality
RUSD does not Granger Cause RKLCI	0.236	0.790048314	Unidirectional causality
RKLCI does not Granger Cause RUSD	8.501	0.000269684*	
RGBP does not Granger Cause RKLCI	0.264	0.76843615	Unidirectional causality
RKLCI does not Granger Cause RGBP	3.717	0.025683689**	
REURO does not Granger Cause RKLCI	0.098	0.906640651	Unidirectional causality
RKLCI does not Granger Cause REURO	8.637	0.000237692*	
RSGD does not Granger Cause RKLCI	0.706	0.494482477	Unidirectional causality
RKLCI does not Granger Cause RSGD	9.554	0.000101172*	
RTHAI does not Granger Cause RKLCI	1.984	0.139717695	Unidirectional causality
RKLCI does not Granger Cause RTHAI	3.307	0.038270282**	

Denotes: \* significant at 1% \*\*significant at 5% \*\*\*significant at 10%

The causal relationship can be seen more clearly by transforming information from table 4 in to Figure 1.

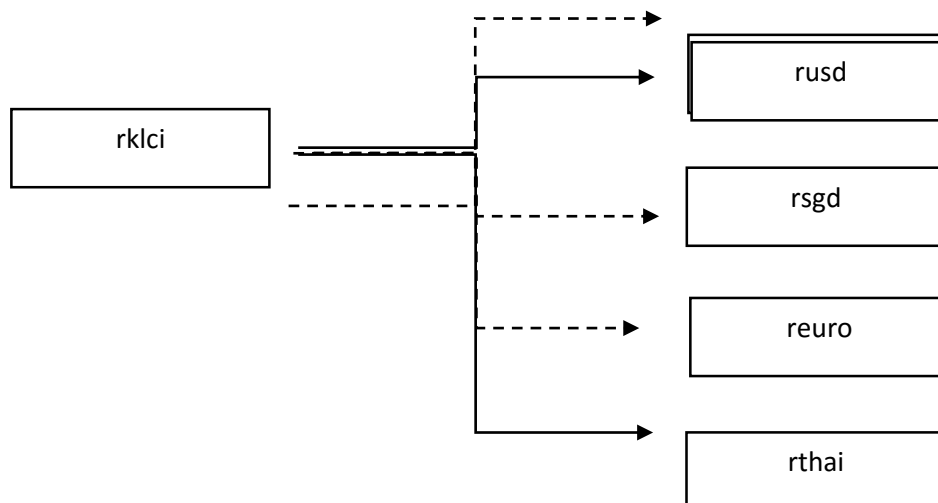

Figure 1: Causal relationship between stock price and foreign exchange rate



## INDICATOR

→ Granger cause at 5% significant

--→ Granger cause at 1% significant

## 5. Conclusion

Based on the empirical evidence in this paper, the Granger causality tests revealed that the changes stock prices lead to the foreign exchange rates. Thus, one of the practical implication of this study is that the policy makers or economists of the Malaysian economy should be more cautious in implementing and executing the stock market policies since it has a short term relation towards the exchange rate. However, this study supported the finding of Abdalla and Murinde (1997) and Gopalan Kutty (2010), who concluded that the stock price Granger cause the exchange rate.

## References

Abdalla, I.S.A & Murinde, V. (1997). Exchange rate and stock price interaction in emerging financial markets: Evidence on India, Korea, Pakistan and the Philippines. *Applied Financial Economics*, 7, 25-35. doi: 10.1080/096031097333826

Ajayi, R.A & Mougoue, M. (1996). On the dynamic relation between stock prices and exchange rates. *The Journal of Financial Research*, 19(2), 193-207. doi: 10.1111/j.1475-6803.1996.tb00593.x

Bahmani-Oskooee, M. & Sohrabian, A. (1992). Stock price and the effective exchange rate of the dollar. *Applied Economics*, 24, 459-464. doi: 10.1080/00036849200000020

Bartram, S.M & Bodnar, G.M (2012). Crossing the lines: The conditional relation between exchange rate exposure and shock returns in emerging and developed markets. *Journal of International Money and Finance*, 31, 766-792. doi: <http://dx.doi.org/10.1016/j.jimonfin.2012.01.011>

Chen, S. & Chen, T. (2012). Untangling the non-linear causal nexus between exchange rates and stock prices: New evidence from the OECD countries. *Journal of Economic Studies*, 39, 231-259. doi: <http://dx.doi.org/10.1108/01443581211222671>

Doong, S., Yang, S. & Wang, A.T. (2005). The dynamic relationship and pricing of stocks and exchange rates: Empirical evidence from Asian emerging markets. *Journal of American Academy of Business*, 7, 118-123.

Gopalan Kutty. (2010). The Relationship between Exchange Rate and Stock Prices: The Case of Mexico. *North American Journal of Finance and Banking Research*, 4(4).

Hatemi-J, A & Roca, M. (2005). On the causality between exchange rate and stock price: A note. *Bulletin of Economic Research*, 54(2). 209-232. doi: 10.1111/1467-8586.00148

Inci, A.C. & Lee, B. (2014). Dynamics relations between stock price and exchange rate changes. *European Financial Management*, 20. 71-106. doi: 10.1111/j.1475-6803.1996.tb00593.x

Kim, K. (2003). Dollar Exchange Rate and Stock Price: Evidence from Multivariate Co-Integration and Error Correction Model, *Review of Financial Economics* 12. doi: [http://dx.doi.org/10.1016/S1058-3300\(03\)00026-0](http://dx.doi.org/10.1016/S1058-3300(03)00026-0)

Kurihara, Y. (2006). The Relationship between Exchange Rate and Stock Prices during the QE Policy in Japan, *International Journal of Business*, 11(4).

Mishra, A.K. (2005). Stock market and foreign exchange market in India: Are they related. *South Asia Economic Journal*, 5(2), 209-232. doi: 10.1177/139156140400500202

Mohamed Ariff & Syarisa Yanti Abu Bakar (1999). The Malaysian Financial Crisis: Economic Impact and Recovery Prospects, *The Developing Economies XXXVII*, 4,417-438.

Nieh, C. & Lee, C. (2001). Dynamic relationship between stock price and exchange rate for G-7 countries. *The Quarterly Review of Economics and Finance*, 41, 477-490. doi: [http://dx.doi.org/10.1016/S1062-9769\(01\)00085-0](http://dx.doi.org/10.1016/S1062-9769(01)00085-0)

Patra, T & Poshakwale, S. (2006). Economic variables and stock market returns: Evidence from the Athens stock exchange. *Applied Financial Economics*, 16, 993-1005. doi: 10.1080/09603100500426523