



UNIVERSITI SAINS MALAYSIA

KSCP Examination  
2016/2017 Academic Session

August 2017

**EAS254 – Structural Analysis**  
*[Analisis Struktur]*

Duration : 3 hours  
*[Masa : 3 jam]*

---

Please check that this examination paper consists of **EIGHT (8)** pages of printed material including appendix before you begin the examination.

*[Sila pastikan bahawa kertas peperiksaan ini mengandungi **LAPAN (8)** muka surat yang bercetak termasuk lampiran sebelum anda memulakan peperiksaan ini.]*

**Instructions** : This paper consists of **SIX (6)** questions. Answer **FIVE (5)** questions.

**Arahan** : Kertas ini mengandungi **ENAM (6)** soalan. Jawab **LIMA (5)** soalan.]

In the event of any discrepancies, the English version shall be used.

*[Sekiranya terdapat percanggahan pada soalan peperiksaan, versi Bahasa Inggeris hendaklah diguna pakai.]*

1. [a] Use the virtual work method to determine the vertical deflection and rotation angle at joint B of the frame shown in **Figure 1**. Take  $E = 200 \text{ GPa}$  and  $I = 600 \times 10^6 \text{ mm}^4$ .

*Guna kaedah kerja maya untuk menentukan anjakan pugak dan sudut putaran sambungan B untuk kerangka yang ditunjukkan dalam **Rajah 1**. Guna  $E = 200 \text{ GPa}$  and  $I = 600 \times 10^6 \text{ mm}^4$ .*

[15 marks/markah]

- [b] Determine the vertical deflection at joint B considering the axial work. Take  $A = 150 \text{ mm}^2$ .

*Kira anjakan pugak sambungan B dengan mengambilkira kerja paksi. Guna  $A = 150 \text{ mm}^2$ .*

[5 marks/markah]

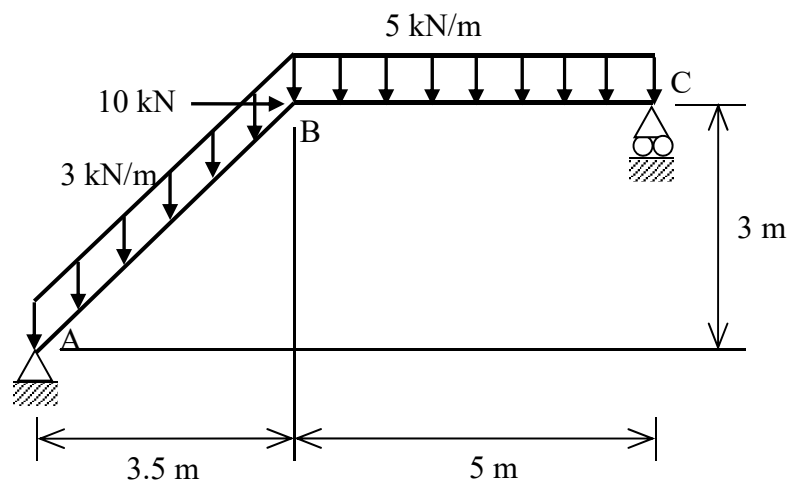

**Figure/Rajah 1**

2. A two-span continuous steel beam as shown in **Figure 2** is supporting a uniformly distributed load of 15 kN/m along span AB and a concentrated load of 50 kN at C. The continuous beam is supported by a pin at A and by a roller at B and D. Determine the reaction at all supports A, B and D of the continuous beam by the method of least work. The span AB and BD of the beams have the second moment of area of  $79100 \text{ cm}^4$  and  $57100 \text{ cm}^4$ , respectively. The Young's modulus of the beam is  $30 \text{ GN/m}^2$ . Ignore self-weight of the beam.

*Sebuah rasuk selangar keluli dua-rentang seperti ditunjukkan dalam **Rajah 2** menyokong beban teragih seragam 15 kN/m sepanjang rentang AB dan satu beban tumpu 50 kN di C. Rasuk selangar tersebut disokong pin di A dan rola di B dan D. Tentukan tindakbalas di semua penyokong A, B dan D rasuk selangar tersebut menggunakan kaedah kerja terkurang. Rentang AB dan BD rasuk tersebut mempunyai momen luas kedua masing-masing  $79100 \text{ cm}^4$  dan  $57100 \text{ cm}^4$ . Modulus keanjalan rasuk keluli adalah  $30 \text{ GN/m}^2$ . Abaikan berat-diri rasuk tersebut.*

[20 marks/markah]

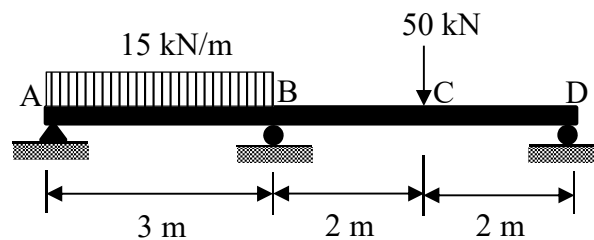

**Figure / Rajah 2**

3. **Figure 3** shows a frame carrying a triangular load for span BC and a point load of 5 kN at mid-point on span AB. Supports at A and D are fixed and assume that  $EI$  is constant except for span CD.

*Rajah 3* menunjukkan satu kerangka yang membawa beban segitiga pada rentang BC dan beban tumpuan 5 kN di titik tengah rentang AB. Penyokong di A dan D adalah jenis terikat dan anggap  $EI$  adalah pemalar kecuali bagi rentang CD.

Compute the internal moments at the joint of the frame by using the Slope Deflection Method.

Kira nilai momen dalaman di setiap penyokong kerangka tersebut dengan menggunakan Kaedah Cerun Pesongan.

[20 marks/markah]

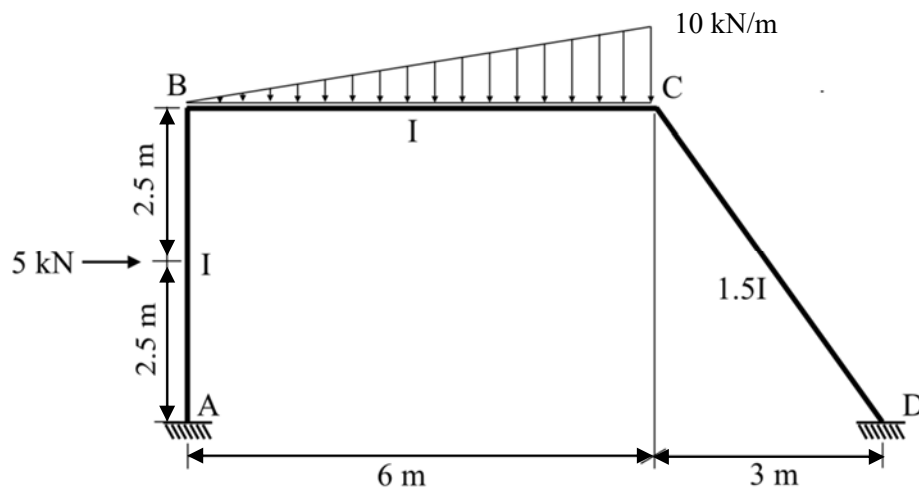

**Figure / Rajah 3**

4. **Figure 4** shows a beam section carrying a uniformly distributed load of 40 kN/m along span AC and point load 10 kN at joint D. Support at A is fixed and supports B and C can be treated as a hinged. Assume that EI is constant unless noted in the figure.

*Rajah 4* menunjukkan bahagian rasuk yang membawa beban teragih seragam 40 kN/m sepanjang rentang AC dan beban tumpu sebanyak 10 kN di penyokong D. Penyokong di A ialah jenis terikat dan penyokong di B dan C boleh diperlakukan sebagai engsel. Anggap EI adalah pemalar jika tidak dinyatakan di dalam rajah.

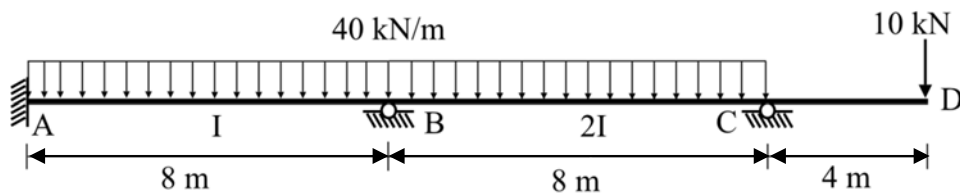

**Figure / Rajah 4**

- [a] Compute the internal moments at the joint of the section by using the Moment Distribution Method.

*Kira nilai momen dalaman di setiap penyokong kerangka tersebut dengan menggunakan Kaedah Agihan Momen.*

[15 marks/markah]

- [b] Sketch the shear force diagram, bending moment diagram and deflected shape for each member of the section.

*Lakarkan gambarajah daya ricih, momen lentur dan bentuk pesongan bagi setiap anggota kerangka tersebut.*

[5 marks/markah]

5. **Figure 5** shows a rigid-jointed frame to carry the working loads. If the collapse load factor is to be 1.2, determine the required plastic moment capacity ( $M_p$ ) for all possible mechanisms.

*Rajah 5* menunjukkan sebuah kerangka terikat tegar dengan beban kerja. Jika faktor beban runtuh ialah 1.2, tentukan kapasiti momen plastik ( $M_p$ ) yang diperlukan untuk semua mekanisma yang mungkin berlaku.

[20 marks/markah]

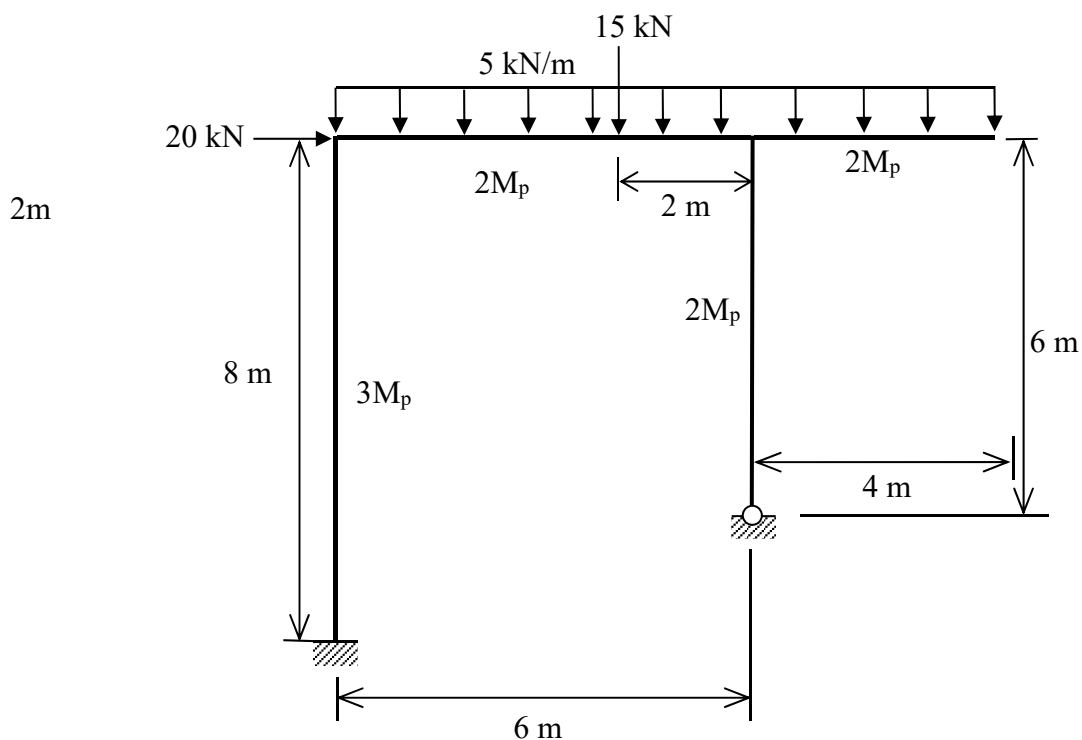
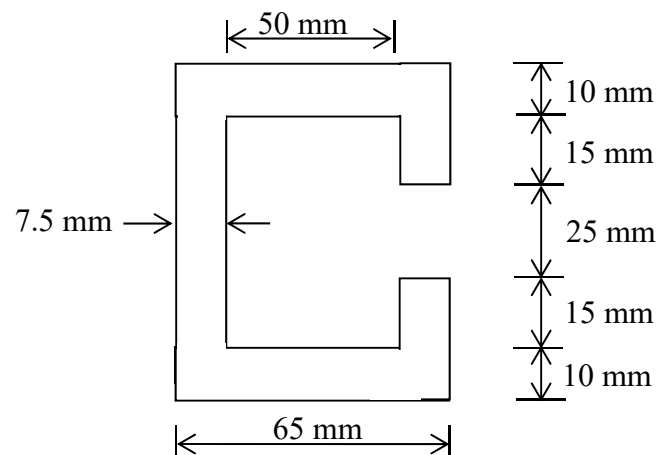

**Figure / Rajah 5**

6. [a] A section of the steel beam for the frame is shown in **Figure 6**. Determine the plastic moment capacity, elastic moment capacity and shape factor of the beam section. The yield stress of steel is  $275 \text{ N/mm}^2$ .

Keratan rasuk keluli untuk kerangka diberikan dalam **Rajah 6**. Kira kapasiti momen plastik, kapasiti momen elastik dan faktor bentuk keratan rasuk. Tegangan alah untuk keluli ialah  $275 \text{ N/mm}^2$ .

[10 marks/markah]

**Figure / Rajah 6**

- [b] A beam shown in **Figure 7** is loaded with uniformly distributed and point loads. Use virtual work method to determine the ultimate collapse load if the plastic moment capacity of the beam is  $150 \text{ kNm}$ .





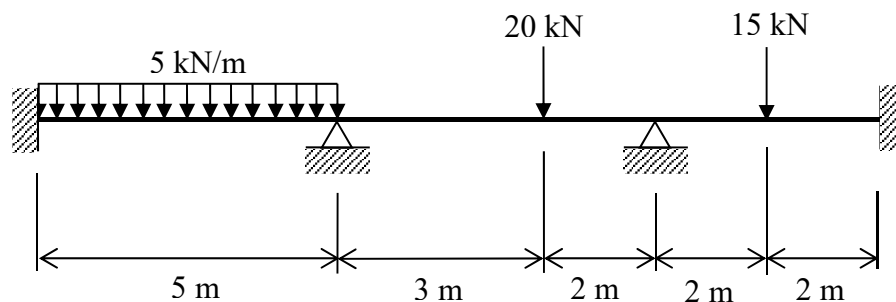

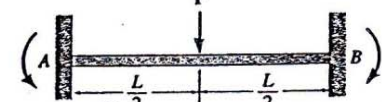
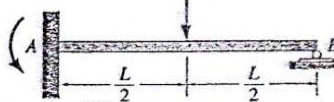
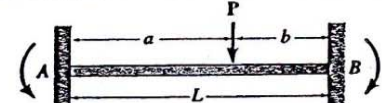
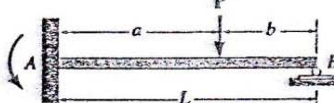

Rasuk keluli yang ditunjukkan dalam **Rajah 7** dikenakan beban teragih seragam dan beban tumpu. Guna kaedah kerja maya untuk menentukan beban muktamad runtuh jika kapasiti momen plastik rasuk ialah  $150 \text{ kNm}$ .

[10 marks/markah]

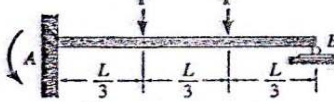
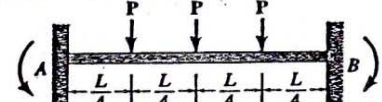
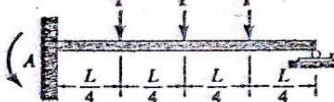
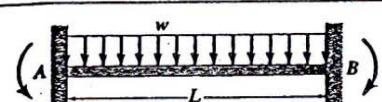
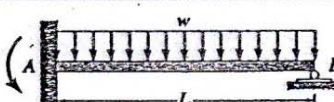
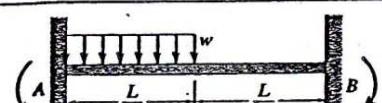
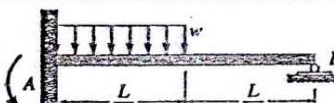
**Figure/ Rajah 7**

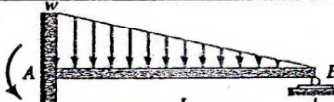
**APPENDIX / LAMPIRAN**

**Fixed End Moments**

 <p> <math>(FEM)_{AB} = \frac{PL}{8}</math> <math>(FEM)_{BA} = \frac{PL}{8}</math> </p>	 <p> <math>(FEM)'_{AB} = \frac{3PL}{16}</math> </p>
 <p> <math>(FEM)_{AB} = \frac{Pb^2a}{L^2}</math> <math>(FEM)_{BA} = \frac{Pa^2b}{L^2}</math> </p>	 <p> <math>(FEM)'_{AB} = \left(\frac{P}{L^2}\right)(b^2a + \frac{a^2b}{2})</math> </p>
 <p> <math>(FEM)_{AB} = \frac{2PL}{9}</math> <math>(FEM)_{BA} = \frac{2PL}{9}</math> </p>	 <p> <math>(FEM)'_{AB} = \frac{PL}{3}</math> </p>
 <p> <math>(FEM)_{AB} = \frac{15PL}{48}</math> <math>(FEM)_{BA} = \frac{15PL}{48}</math> </p>	 <p> <math>(FEM)'_{AB} = \frac{45PL}{96}</math> </p>
 <p> <math>(FEM)_{AB} = \frac{wL^2}{12}</math> <math>(FEM)_{BA} = \frac{wL^2}{12}</math> </p>	 <p> <math>(FEM)'_{AB} = \frac{wL^2}{8}</math> </p>
 <p> <math>(FEM)_{AB} = \frac{11wL^2}{192}</math> <math>(FEM)_{BA} = \frac{5wL^2}{192}</math> </p>	 <p> <math>(FEM)'_{AB} = \frac{9wL^2}{128}</math> </p>
 <p> <math>(FEM)_{AB} = \frac{wL^2}{20}</math> <math>(FEM)_{BA} = \frac{wL^2}{30}</math> </p>	 <p> <math>(FEM)'_{AB} = \frac{wL^2}{15}</math> </p>
 <p> <math>(FEM)_{AB} = \frac{5wL^2}{96}</math> <math>(FEM)_{BA} = \frac{5wL^2}{96}</math> </p>	 <p> <math>(FEM)'_{AB} = \frac{5wL^2}{64}</math> </p>
 <p> <math>(FEM)_{AB} = \frac{6EI\Delta}{L^2}</math> <math>(FEM)_{BA} = \frac{6EI\Delta}{L^2}</math> </p>	 <p> <math>(FEM)'_{AB} = \frac{3EI\Delta}{L^2}</math> </p>