



UNIVERSITI SAINS MALAYSIA

KSCP Examination
2016/2017 Academic Session

August 2017

EAS253 – Theory of Structures
[Teori Struktur]

Duration : 3 hours
[Masa : 3 jam]

Please check that this examination paper consists of **TWELVE (12)** pages of printed material before you begin the examination.

*[Sila pastikan bahawa kertas peperiksaan ini mengandungi **DUA BELAS (12)** muka surat yang bercetak sebelum anda memulakan peperiksaan ini.]*

[Instructions: This paper contains **SEVEN (7)** questions. Answer **THREE (3)** questions in **Part A** and **TWO (2)** questions in **Part B.**]

*[Arahan: Kertas ini mengandungi **TUJUH (7)** soalan. Jawab **TIGA (3)** soalan di **Bahagian A** dan **DUA (2)** soalan di **Bahagian B.**]*

In the event of any discrepancies, the English version shall be used.

[Sekiranya terdapat percanggahan pada soalan peperiksaan, versi Bahasa Inggeris hendaklah diguna pakai.]

PART A : Answer all THREE (3) questions

1. **Figure 1** shows a frame with pinned and roller supports at A and D, respectively. It is loaded by a uniformly distributed load 15 kN/m along inclined members BCD, a horizontal concentrated load 25 kN at joint B and a vertical concentrated load 30 kN at point C.

Rajah 1 menunjukkan satu kerangka dengan penyokong pin dan rola masing-masing di A dan D. Kerangka berkenaan dikenakan satu beban teragih seragam 15 kN/m di sepanjang anggota condong BCD, satu beban tertumpu ufuk 25 kN di sambungan B dan satu beban tertumpu pugak 30 kN di titik C.

- [a] Show that the frame is statically determinate.

Tunjukkan bahawa kerangka berkenaan adalah boleh tentu statik.

- [b] Draw the shear force and bending moment diagrams for the frame. Sketch also the qualitative deflected shape.

Lukis gambarajah daya ricih dan momen lentur untuk kerangka berkenaan. Juga, lakarkan bentuk pesongan kualitatif.

- [c] Determine the axial force in member AB. Indicate if it is compression or tension.

Tentukan daya paksi dalam anggota AB. Nyatakan sama ada ia adalah dalam keadaan tegangan atau mampatan.

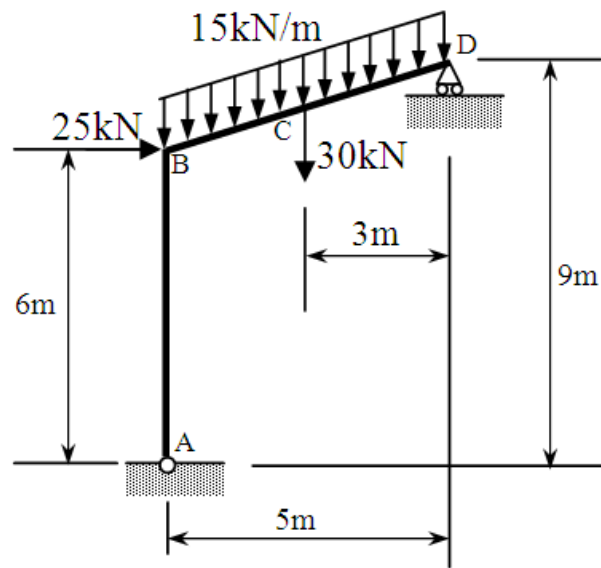

Figure 1/Rajah 1

[20 marks/markah]

2. [a] The moment-area method utilizes graphical interpretations of integrals involved in the solution of the deflection differential equation in terms of the areas and the moments of areas of the M/EI diagram. Using a beam subjected to arbitrary loading and the equation for change in slope ($d\theta$) of the elastic curve over the differential length dx as $d\theta = \frac{M}{EI} dx$, derive the moment-area theorems.

Kaedah momen-luas menggunakan interpretasi grafik integral yang terlibat dalam penyelesaian bagi persamaan perbezaan pesongan dalam sebutan luas dan momen luas untuk gambarajah M/EI . Dengan menggunakan rasuk yang dikenakan beban sembarangan dan persamaan untuk perubahan dalam kecerunan ($d\theta$) bagi lengkung elastik terhadap jarak pembezaan dx sebagai $d\theta = \frac{M}{EI} dx$ dapatkan teorem momen-luas.

[8 marks/markah]

- [b] A beam as shown in **Figure 2** is subjected to two point loads of 25 kN and 20 kN at points B and C, respectively, and a concentrated moment of 10 kNm at point A. Using $E = 200$ GPa and $I = 300(10^6)$ mm⁴, calculate the maximum deflection of the beam. Use either moment-area method or conjugate-beam method.

*Satu rasuk seperti yang ditunjukkan dalam **Rajah2** dikenakan beban tumpu 25 kN dan 20 kN masing-masing di titik B dan C dan momen tertumpu 10 kNm di titik A. Menggunakan $E = 200$ GPa dan $I = 300(10^6)$ mm⁴, kirakan pesongan maksimum rasuk. Guna kaedah momen-luas atau kaedah rasuk konjugat.*

[12 marks/markah]

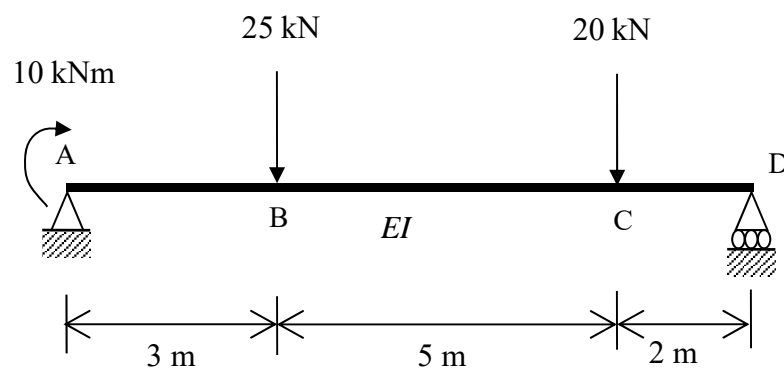

Figure 2/Rajah 2

3. [a] **Figure 3** shows a plane truss used as a gantry for a crane of capacity 100 kN. Check for the statical determinacy of the truss. Support F is roller and support J is pinned. All member connections are pinned. Find the reactions at both supports and identify any zero force members, if any. Determine forces in member EI, DI and DH by using section method and members FG, JK and FJ by using joint method. Classify whether they are in tension or compression.

Rajah 3 menunjukkan satu kekuda satah yang digunakan sebagai gantri kren dengan kapasiti 100 kN. Semak kebolehtentuan statik kekuda berkenaan. Penyokong *F* adalah rola manakala penyokong *J* adalah pin. Semua sambungan anggota adalah pin. Kira nilai daya tindakbalas di kedua penyokong dan kenalpasti anggota kekuda yang mungkin mempunyai daya sifar, sekiranya ada. Kira daya dalam anggota *EI*, *DI* and *DH* menggunakan kaedah keratan dan anggota *FG*, *JK* dan *FJ* menggunakan kaedah sambungan. Nyatakan sama ada anggota tersebut mengalami daya mampatan atau tegangan.

[16 marks/markah]

- [b] If two members *MI* and *ML* of the truss shown in **Figure 3** are removed, what will happen to the overall stability of the truss? Any changes of the forces in members *EI*, *DI* and *DH*?

Sekiranya dua anggota *MI* dan *ML* kekuda dalam **Rajah 3** dikeluarkan, apakah yang akan berlaku kepada kestabilan kekuda tersebut? Adakah sebarang perubahan nilai daya dalam anggota *EI*, *DI* dan *DH*?

[4 marks/markah]

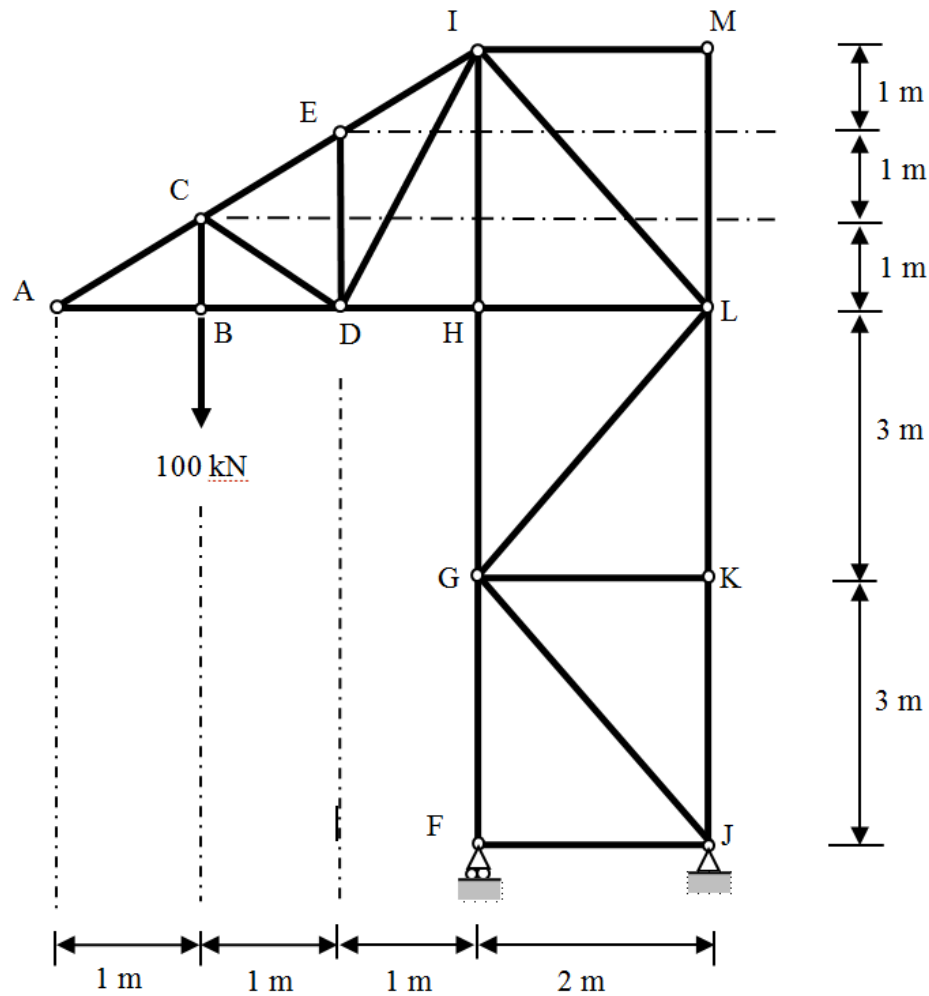

Figure 3/Rajah 3

PART B : Choose TWO (2) questions

4. [a] The cable-supported foot bridge shown in **Figure 4** is composed of 6 equally spaced hangers of 4 m apart. Each hanger can be assumed to provide a simple support for the suspended beam with a 50 kN load at both ends and 30 kN for intermediate hangers. Determine the tension forces in each segment of the cables, the total length of cable and the tension forces at both supports. Assume the self weight of the suspended beam is negligible.

Kabel menyokong jambatan gantung yang ditunjukkan dalam **Rajah 4**, terdiri daripada 6 tali pengantung yang berjarak sama sebanyak 4 m. Setiap hangar dianggap sebagai penyokong mudah rasuk jambatan yang tergantung dengan beban 50 kN untuk hangar tepi dan 30 kN untuk hangar bahagian dalam. Kira daya tegangan untuk setiap segmen kabel, panjang keseluruhan kabel dan nilai daya tegangan di kedua-dua penyokong. Anggap beban sendiri rasuk jambatan boleh diabaikan.

[16 marks/markah]

- [b] What is the required area of the cable if the allowable stress is 160000 kN/m^2 ? In your opinion, does the cable size reduce if the number of hanger reduces from 6 to 4?

Berapakah saiz kabel yang diperlukan sekiranya tegasan kabel tersebut ialah 160000 kN/m^2 ? Pada pandangan anda, adakah dengan pengurangan jumlah hangar dari 6 kepada 4 akan mengurangkan saiz kabel?

[4 marks/markah]

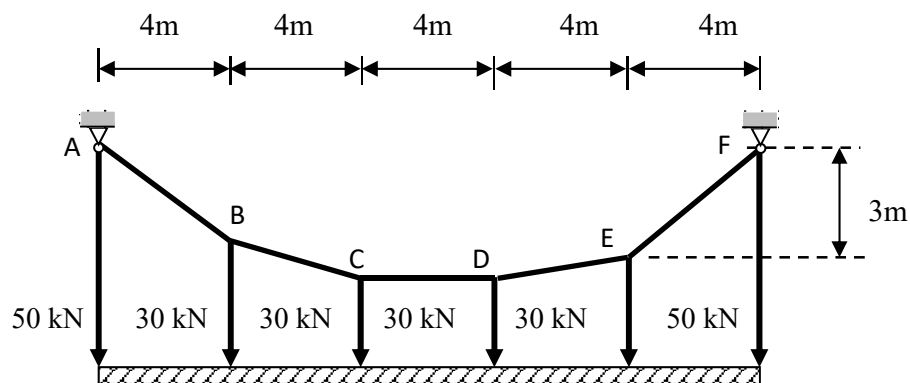

Figure 4/Rajah 4

5. [a] What is the main difference between the two-pinned and three-pinned arch structures?

Apakah perbezaan utama antara struktur gerbang dua-pin dan tiga pin?

[4 marks/markah]

- [b] The three-pinned parabolic arch in **Figure 5** supports vertical point loads of 20 kN, 20 kN, 20 kN at points B, C, D. Apart from that, horizontal point loads 10 kN and 5 kN act at point B and D, respectively. It also carries a uniformly distributed load of 8 kN/m on span ABC. Determine the support reactions, bending moment at B and D and the shear force, Q and thrust, N at point D (with loading).

*Gerbang tiga engsel berbentuk parabolic dalam **Rajah 5** menyokong beban tumpu sebanyak 20kN, 20kN, 20kN di titik B, C, D. Selain daripada itu, beban tertumpu ufuk 10 kN dan 5 kN masing-masing bertindak pada B dan D. Ia juga membawa beban teragih seragam sebanyak 8 kN/m di rentang ABC. Tentukan daya tindakbalas di penyokong, momen lentur di titik B dan D serta daya ricih, Q dan daya paksi N di titik D (dengan beban kenaan).*

[16 marks/markah]

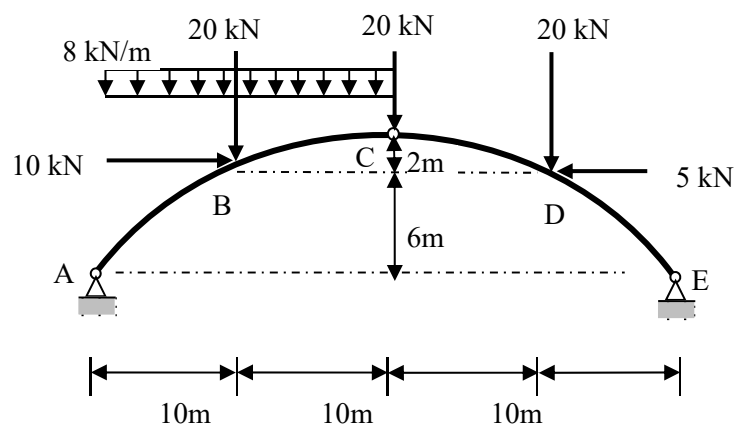

Figure 5/Rajah 5

6. [a] **Figure 6** shows an analytical model of a three-span beam. The beam is pinned supported at A, D and roller supported at B, C. Check statical determinacy of the beam.

Rajah 6 menunjukkan satu model analitik satu rasuk tiga-rentang. Rasuk berkenaan disokong oleh penyokong pin pada A, D dan penyokong rola di B, C. Semak kebolehtentuan statik rasuk berkenaan.

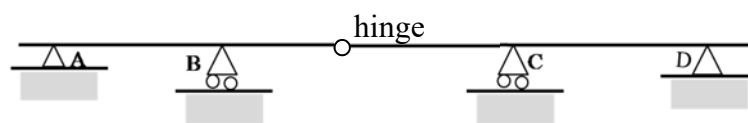

Figure 6/Rajah 6

[2 marks/markah]

- [b] **Figure 7** shows a beam structure with pinned support at A, roller supports at B, D and hinge joint at C. The beam is loaded with a uniformly distributed load 10 kN/m and 20 kN/m along spans AB and BCD, respectively; a linearly distributed load varying from 20 kN/m at D until 0 kN/m at E along overhang span DE; and a couple 20 kNm at free end E. Draw the shear force and bending moment diagrams for the beam. Sketch also the qualitative deflected shape.

Rajah 7 menunjukkan satu struktur rasuk dengan penyokong pin di A, penyokong rola di B, D dan sambungan sendi di C. Rasuk berkenaan membawa beban teragih seragam 10 kN/m dan 20 kN/m di sepanjang rentang AB dan BCD; satu beban teragih lurus yang berubah dari 20 kN/m di D sehingga 0 kN/m di E di sepanjang rentang terjulur DE; dan satu gandingan 20 kNm di hujung bebas E. Lukiskan gambarajah daya ricih dan momen lentur untuk rasuk berkenaan. Lakarkan juga bentuk terpesong kualitatif.

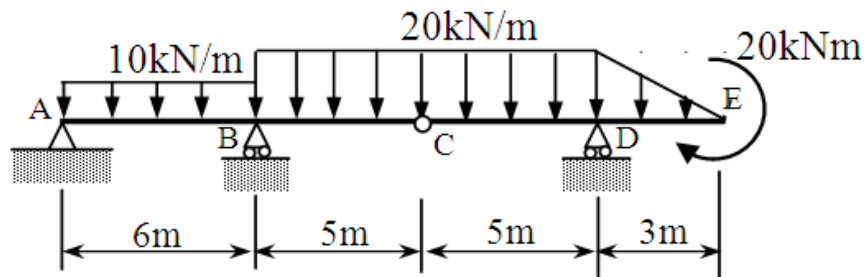

Figure 7/Rajah 7

[18 marks/markah]

7. [a] **Figure 8** shows a bridge frame which is constructed to allow vehicle to travel on it. Point D is an internal hinge. Draw the influence lines for

Rajah 8 menunjukkan satu kerangka jambatan yang dibina untuk kenderaan melaluinya. Titik D adalah satu sambungan pin dalaman. Lukis garis imbas untuk

- [i] the reactions at supports A, B and E,
tindakbalas di penyokong A, B dan E,
- [ii] the shear at point C which is just to the right of beam to column connection, and
daya ricih di titik C yang berada hanya ke kanan sedikit daripada sambungan rasuk ke tiang, dan
- [iii] the bending moment at point F.
momen lentur di titik F

[12 marks/markah]

- [b] Determine the maximum values of the reaction forces at support A, shear at point C and bending moment at point F due to a truck travels from point B to point E.

Tentukan nilai maksimum untuk tindakbalas di penyokong A, daya ricih di titik C dan momen lentur di titik F disebabkan sebuah lori yang bergerak dari titik B ke titik E.

[8 marks/markah]

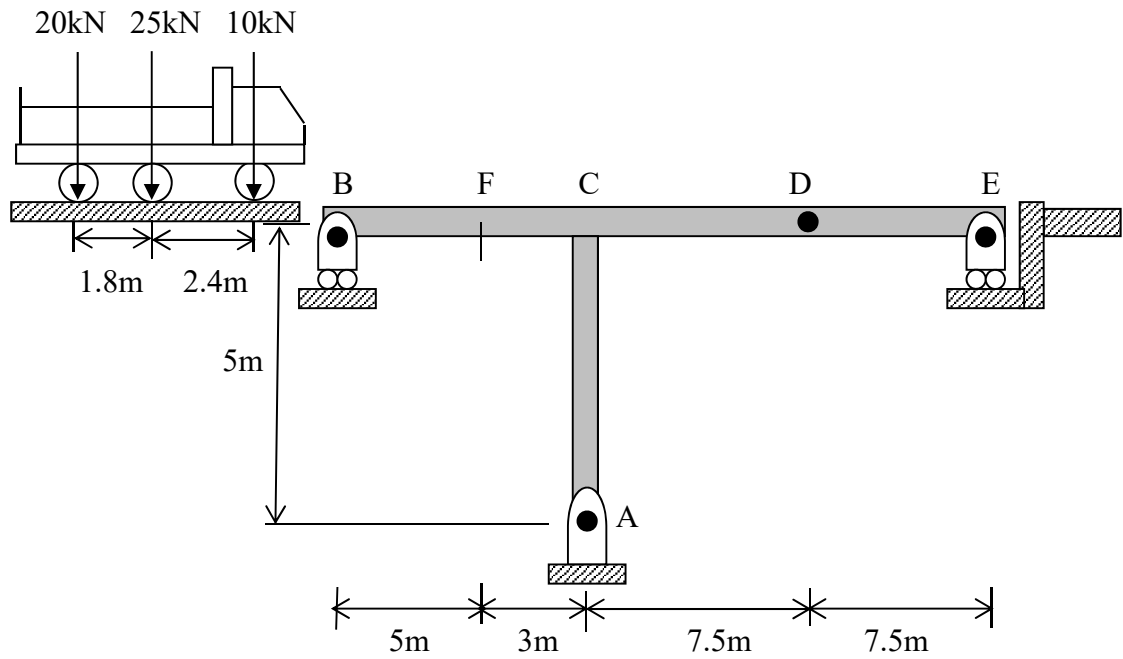
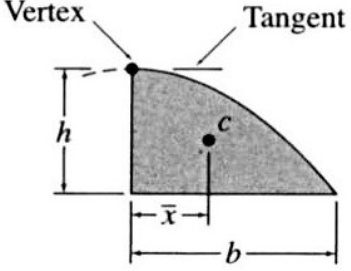
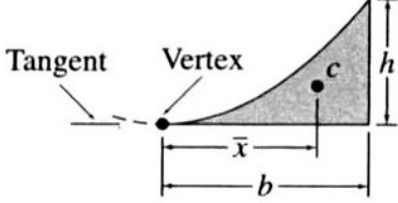
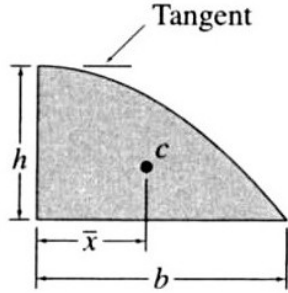
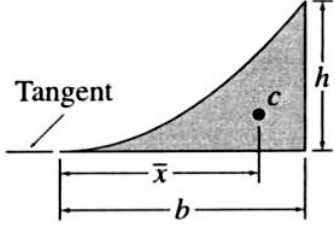

Figure 8/Rajah 8

Appendix/Lampiran

Areas and Centroids of Geometric Shapes

Shape	Area	Centroid
<p>Semi-parabola</p>  <p>Vertex</p> <p>Tangent</p> <p>h</p> <p>\bar{x}</p> <p>b</p> <p>c</p>	$A = \frac{2bh}{3}$	$\bar{x} = \frac{3b}{8}$
<p>Parabolic spandrel</p>  <p>Tangent</p> <p>Vertex</p> <p>h</p> <p>\bar{x}</p> <p>b</p> <p>c</p>	$A = \frac{bh}{3}$	$\bar{x} = \frac{3b}{4}$
<p>Cubic</p>  <p>Tangent</p> <p>h</p> <p>\bar{x}</p> <p>b</p> <p>c</p>	$A = \frac{3bh}{4}$	$\bar{x} = \frac{2b}{5}$
<p>Cubic spandrel</p>  <p>Tangent</p> <p>h</p> <p>\bar{x}</p> <p>b</p> <p>c</p>	$A = \frac{bh}{4}$	$\bar{x} = \frac{4b}{5}$