

**A SINGLE-STAGE DUAL OUTPUT AC/DC  
CONVERTER WITH PFC FOR SUPPLYING LED  
LIGHT**

**ASHRAF MOHAMMAD BANI AHMAD**

**UNIVERSITI SAINS MALAYSIA**

**2017**

**A SINGLE-STAGE DUAL OUTPUT AC/DC CONVERTER WITH PFC FOR  
SUPPLYING LED LIGHT**

**By**

**ASHRAF MOHAMMAD BANI AHMAD**

**A Dissertation submitted for partial fulfilment of the requirement**

**for the degree of Master of Science**

**(Electronic Systems Design Engineering)**

**July 2017**

## ACKNOWLEDGEMENTS

First of all, I would like to thank and praise almighty Allah from the depths of my heart, for giving me the opportunity to pursue master degree study in Malaysia and providing me with the ability and patience upon facing difficulties during all this time. Praise be to Allah at the beginning and the end of everything.

To my supervisor Associate Professor Ir. Dr. Dahaman Ishak, I wish to express my sincere gratitude to you, without you, this research would not have been achieved and shown in this form. Thank you for your supervision, assistance, guidance, motivation, encouragement and continuous support throughout this research work. May God reward you with paradise.

I would like to express my sincere gratitude to my teachers Prof. Ir. Dr. Mohd Rizal Arshad, Assoc. Prof. Ir. Dr. Syafrudin Masri, Dr. Shahid Iqbal, Dr. Ooi Chia Ai and all lecturers of School of Electrical and Electronic Engineering. And I do not forget to give my thanks for the Universiti Sains Malaysia for everything. I want to express my sincere gratitude to my friends, Dr. Muhammad Imran, Nurul Zawawi, Elias Ait Tayeb, my cousin Ali Ayasrah, Hisham Haider, Tariq Adnan, Sami Abdullah for their assistance and encouragement during this research work. I am also thankful to all my friends in of School of Electrical and Electronic Engineering and in Universiti Sains Malaysia.

Finally, I wish to record my sincere gratitude to my family, father, mother, brothers and sisters for encouragement and continuous support for me to continue my graduate studies.

## TABLES OF CONTENTS

	Page
<b>ACKNOWLEDGEMENTS</b>	II
<b>TABLES OF CONTENTS</b>	III
<b>LIST OF TABLES</b>	VII
<b>LIST OF FIGURES</b>	VIII
<b>LIST OF SYMBOLS</b>	XI
<b>LIST OF ABBREVIATIONS</b>	XV
<b>ABSTRAK</b>	XVII
<b>ABSTRACT</b>	XIX
<b>CHAPTER ONE: INTRODUCTION</b>	
1.1 Background and Motivation	1
1.2 Luminous Light Technology Development	2
1.2.1 Incandescent Lamps	3
1.2.2 Fluorescent Lamps	3
1.2.3 Tungsten Halogen Lamps	3
1.2.4 High-Intensity Discharge Lamps	4

1.3	Light-Emitting Diode (LED) Technology	4
1.4	Problem Statement	6
1.5	Research Objectives	7
1.6	Scope of Research Work	7
1.7	Research Contributions	8
1.8	Thesis Outlines	8
 <b>CHAPTER TWO: LITERATURE REVIEW</b>		
2.1	Introduction	10
2.2	LED, Structure and Operating Principle	10
2.3	Advantages of LED	13
2.3.1	Higher Efficiency	13
2.3.2	Higher Power Factor	14
2.3.3	Lower Harmonic Distortion	14
2.3.4	Longer Life Span	15
2.3.5	Other Features	16
2.4	Electrical Characteristics of LED Driver	16
2.4.1	Forward Voltage and Current	16
2.4.2	Junction Temperature	18

2.5	Single-Phase AC/DC Converters for LED Driver	20
2.5.1	Power Factor Correction	22
2.5.2	LLC Resonant Converter	27
2.6	Topologies of AC/DC Converters for LED Driver	29
2.7	Summary	40
<b>CHAPTER THREE: METHODOLOGY</b>		
3.1	Introduction	41
3.2	Flow Chart	42
3.3	The Proposed Single-Stage Dual output AC/DC Converter with PFC for Supplying LED Light	43
3.3.1	Analysis of Steady State Operation	45
3.3.2	Analysis of Gain Characteristics of Converter	56
3.4	Design and Simulation of Single-Stage Dual Output AC/DC Converter with PFC	61
3.4.1	Design Specifications	61
3.4.2	Parameters Design and Calculation for the Proposed Topology	63
3.4.3	Simulation Model of the Proposed Topology	69
3.5	Summary	72

## **CHAPTER FOUR: RESULTS AND DISCUSSION**

4.1	Introduction	73
4.2	Simulation Results for Single-Stage Dual Output AC/DC Converter with PFC	73
4.3	Summary	87

## **CHAPTER FIVE: CONCLUSION AND FUTURE WORKS**

5.1	Conclusion	88
5.2	Future Work	89
	<b>REFERENCES</b>	<b>91</b>

## LIST OF TABLES

	Page
Table 1.1 Lighting technology comparison	5
Table 2.1 Comparison between three types of resonant converters	28
Table 3.1 Parameters and values used for the simulation of the proposed LED driver	69
Table 4.1 Simulation results of the proposed converter when the SWr is open	82
Table 4.2 Simulation results of the proposed converter when the SWr is closed	82



## LIST OF FIGURES

	Page
Figure 1.1 Price and efficiency projection for LED technology.	4
Figure 2.1 The atom components.	11
Figure 2.2 LED operating principle.	12
Figure 2.3 Relationship between lumen output and operation time for different types of light technology.	15
Figure 2.4 Relationship between forward voltage with forward current.	17
Figure 2.5 Relationship between relative flux and efficacy with forward current.	18
Figure 2.6 (A) Impact of junction temperatures ( $T_j$ ) on voltage forward ( $\Delta V_f$ ). (B) Impact of junction temperatures on luminous flux ( $\Phi_v$ ).	19
Figure 2.7 Uncontrolled AC/DC full-wave rectifier.	21
Figure 2.8 Passive PFC method.	23
Figure 2.9 Active PFC method and waveform of the input current and voltage.	24
Figure 2.11 The block diagram of single-stage converter.	27
Figure 2.12 Basic types of resonant tank.	28
Figure 2.13 Buck converter based LED driver.	31
Figure 2.14 DC/DC boost converter with a passive snubber circuit.	32
Figure 2.15 Circuit scheme for single-phase AC/DC boost converter with active power factor correction (PFC).	33
Figure 2.16 A single-stage AC/DC buck-boost converter based LED driver.	34
Figure 2.17 Single-stage AC/DC buck-boost-flyback converter based LED driver.	35
Figure 2.18 A single-stage boost converter based LED driver.	36

Figure 2.19	A single-stage two-boost converter based LED driver.	37
Figure 2.20	A single-stage LED driver.	39
Figure 3.1	Flow Chart.	42
Figure 3.2	Proposed single-stage dual output AC/DC converter with PFC.	43
Figure 3.3	Key steady-state waveforms of proposed single-stage dual output AC/DC converter with PFC.	46
Figure 3.4	Equivalent circuits for periods 1-8 of proposed single-stage dual output AC/DC converter with PFC.	53
Figure 3.5	Comparison between both states of the relay switch: (a) The proposed topology when the relay switch is turned off (open), (b) The proposed topology when the relay switch is turned on (closed).	54
Figure 3.6	The equivalent circuits of secondary side of transformer for periods 1-8 when the relay switch is turned on (closed): (a) within time period $(t_0-t_3)$ , (b) within time period $(t_5-t_7)$ and (c) within time period $(t_3-t_4)$ and $(t_7-t_8)$ .	55
Figure 3.7	(a) Scheme for equivalent load resistance for secondary-side of the transformer and (b) AC equivalent circuit of resonant tank.	57
Figure 3.8	Simulation model of a single-stage dual output AC/DC converter with PFC.	70
Figure 3.9	Simulation model of the gate signals.	71
Figure 3.10	Measurement block to estimate power factor and efficiency.	72
Figure 4.1	Waveforms obtained from the simulation results for the input current and voltage from AC source.	74

Figure 4.2	Waveform of boost inductor current ( $I_{Lb}$ ).	75
Figure 4.3	Waveforms of the voltage across switches ( $V_{ds1}$ , $V_{ds2}$ ), and between gate source voltage ( $V_{gs1}$ , $V_{gs2}$ ).	76
Figure 4.4	Waveforms of the voltage across switch 1 ( $V_{ds1}$ ) with resonant current ( $I_{Lr}$ ) and secondary current of the transformer ( $I_{sec}$ ).	77
Figure 4.5	Waveforms obtained from the simulation of (a) the gate-source signal 1 ( $V_{gs1}$ ) with the voltage across switch 1 ( $V_{ds1}$ ), (b) the secondary current of the transformer with the voltage across switch 1 ( $V_{ds1}$ ).	78
Figure 4.6	Waveforms of output voltage ( $V_{out}$ ) and output current ( $I_{out}$ ) when the relay switch is open as (a) and closed as (b), respectively.	80
Figure 4.7	Output diode current waveforms (a) currents flowing through diodes ( $i_{Dr1}$ - $i_{Dr4}$ ) when the relay switch ( $SW_r$ ) is open, (b) currents flowing through diodes ( $i_{Dr1}$ - $i_{Dr4}$ ) when the relay switch ( $SW_r$ ) is closed.	81
Figure 4.8	Relationship between output power with power factor (PF), efficiency ( $\eta$ ), total harmonic distortion (THD) and bus voltage ( $V_{bus}$ ), as (a), (b), (c), and (d), respectively, when the relay switch is open and closed, and compared them with the result obtained in [10].	86

## LIST OF SYMBOLS

C1, C2	Voltage divider capacitors
Lb	Boost inductor
Db1, Db2	Boost diodes
SW1, SW2,	Power switches
Cs1, Cs2	Snubber capacitances
Dp1, Dp2	Parasitic diodes
Cbus	Bus voltage capacitor
Cr	Resonant capacitor
Lr	Leakage inductor of transformer
Lm	Magnetizing inductor of transformer
Co1, Co2	Output capacitors
SWr	Relay switch
Rled	Resistance of LED light
Dr1, Dr2, Dr3, Dr4	Output diodes

$D_{i1}, D_{i2}, D_{i3}, D_{i4}$	Input diodes
$i_{Db1}, i_{Db2}$	Boost diode currents
$i_{Dr1} - i_{Dr4}$	Output diode currents
$i_{DS1}, i_{DS2}$	Drain-source current of switches SW1, SW2
$i_{Lb}$	Boost inductor current
$i_{Lr}$	Resonant inductor current
$i_{Lm}$	Magnetizing inductor current
$i_{in}$	Input current
$i_{out}$	Output current
$i_{sec}$	Current at secondary-side of transformer
$G$	Voltage-gain
$n$	Transformer turns ratio
$n_{pri}$	Number of turns for primary winding
$n_{sec}$	Number of turns for secondary winding

$V_{sec}$	Voltage across secondary-side of transformer
$V_{pri}$	Voltage at primary-side of transformer
$P_{out}$	Output power
$K$	Inductance ratio
$Q$	Quality factor
$f_s$	Switching frequency
$f_r$	Resonant frequency
$f_n$	Normalized switching frequency
$f_m$	Magnetizing frequency
$R_{eq}$	Equivalent load resistance
$V_{ab}$	Input square-wave voltage of resonant tank
$V_{abf}$	Fundamental components of input square-wave voltage
$V_{sec f}$	Fundamental component of secondary-side input voltage
$V_{bus}$	Bus voltage
$V_{dS1}, V_{dS2}$	Drain-source voltage of switches SW1, SW2

$V_{gs1}, V_{gs2}$	Gate voltage of switches S1, S2
D	Duty cycle
VAC	Input voltage
Vout	Output voltage
$V_{p1}, V_{p2}$	Voltage peak of output capacitors
$\theta_j$	Phase angle
$\eta$	Efficiency
$\omega_m$	Angular magnetizing frequency
$\omega_r$	Angular resonant frequency
$\omega_s$	Angular switching frequency

## LIST OF ABBREVIATIONS

AC/DC	Alternating Current to Direct Current
CCM	Continuous Conduction Mode
DCM	Discontinuous Conduction Mode
BCM	Boundary Conduction Mode
EMI	Electro-Magnetic Interference
LED	Light-Emitting Diode
HID	High-Intensity Discharge
IEC	International Electro-Technician Commission
LLC	Inductor-Inductor-Capacitor
CCL	Inductor-Capacitor -Capacitor
PRC	Parallel Resonant Converter
SRC	Series Resonant Converter
PFC	Power Factor Correction
PF	Power Factor



THD	Total Harmonic Distortion
ZCS	Zero-Current-Switching
ZVS	Zero-Voltage-Switching
EV	Electric Vehicles
SMPS	Switched Mode Power Supplies
MOSFET	Metal Oxide Semiconductor Field Effect Transition

# **PENUKAR SATU PERINGKAT DUA KELUARAN AU/AT DENGAN PFC UNTUK MEMBEKALKAN LAMPU LED**

## **ABSTRAK**

Lampu LED terkenal kerana mempunyai pelbagai ciri-ciri seperti penjimatan tenaga, jangka hayat yang panjang, percahayaan yang efisien dan kos penyelenggaraan yang rendah. Lampu LED sesuai untuk kegunaan di pelbagai lokasi dan bidang, seperti di dalam atau di luar bangunan dan juga dalam kenderaan elektrik. Penilaian prestasi cahaya LED bergantung kepada nilai yang diambil dari pengukuran faktor kuasa, kecekapan dan jumlah herotan harmonik pemacu LED. Untuk mencapai nilai yang bagus, penukar satu peringkat dua keluaran AU-AT dengan PFC dan hibrid jambatan-penuh penerus adalah dicadangkan dalam tesis ini. Ia boleh digunakan sebagai dua jenis pemacu LED. Apabila keadaan suis geganti (SWR) ditukar daripada suis tutup (terbuka) kepada suis buka(ditutup), peringkat kedua dalam topologi yang dicadangkan ditukar daripada penerus jambatan-penuh (jenis 1) kepada jambatan-penuh voltan berganda penerus (jenis 2). Penukar yang dicadangkan terdiri daripada satu tangki LLC dan dua litar rangsangan dengan satu induktor yang dikongsi. Penukar yang dicadangkan direka untuk menerima bekalan masukan satu-fasa 240 VAC, 50Hz. Pada frekuensi salunan tinggi iaitu 100 kHz dan kitar tugas pada 48.5% telah digunakan untuk suis. Untuk simulasikan penukar yang dicadangkan, perisian MATLAB Simulink telah digunakan. Apabila kuasa keluaran pada 100 W dan relay suis terbuka, faktor kuasa, kecekapan, jumlah herotan harmonik, dan voltan bas didapati bernilai 0.99, 93.3%, 14.53%, dan 338 V, masing-masing. Apabila kuasa keluaran adalah 100 W dan relay suis telah ditutup,

faktor kuasa, kecekapan, jumlah herotan harmonik, dan voltan bas didapati bernilai 0.989, 91.8%, 15.17%, dan 340 V, masing-masing. Di samping itu, ciri-ciri lembut pensuisan telah dicapai. Suis MOSFET dihidupkan semasa pensuisan sifar voltan (ZVS) dan diod keluaran peringkat sekunder dihidupkan semasa pensuisan sifar arus (ZCS). Tambahan lagi, apabila suis geganti telah ditutup, voltan yang keluar adalah dua kali ganda lebih tinggi daripada voltan apabila relay suis terbuka. Ini bermakna aliran arus elektrik yang melalui diod, kapasitor, dan transformer adalah lebih kecil yang menyebabkan pengurangan tekanan pada komponen dan berpotensi untuk meningkatkan kadar jangka hayat operasi mereka.

# **A SINGLE-STAGE DUAL OUTPUT AC/DC CONVERTER WITH PFC FOR SUPPLYING LED LIGHT**

## **ABSTRACT**

LED lights have become the most well-known type of lights, owing to their multiple features such as energy saving, long life-span, good luminous efficacy and low maintenance costs. LED lights are suitable for usage in various locations and fields, such as indoor or outdoor locations, and in electric vehicles. The evaluation of the performance of LED light depends on the values taken from measurement of the power factor, efficiency and total harmonic distortion of the LED driver. To achieve good values, a single-stage dual output AC/DC converter with PFC is proposed in this thesis. It can be used as two distinct types of the LED driver. When the relay switch (SW<sub>r</sub>) state is changed from turned-off (open) to turned-on (closed), the secondary-side of the proposed topology is changed from a full-bridge rectifier (type 1) to a full-bridge voltage doubler rectifier (type 2). The proposed converter consists of one LLC tank and two boost circuits with one shared inductor. The proposed converter is designed to work with 240 VAC, 50Hz single-phase input supply voltage. A high resonant frequency at 100 kHz and a duty cycle at 48.5% were used for the switches. To simulate the proposed converter, MATLAB Simulink software was utilized. When the output power was at 100 W and the relay switch was open, the power factor, efficiency, total harmonic distortion, and bus voltage were found to be 0.99, 93.3%, 14.53%, and 338 V, respectively. When the output power was at 100 W and the relay switch was closed, the power factor, efficiency, total harmonic distortion, and bus voltage were found to be

0.989, 91.8%, 15.17%, and 340 V, respectively. In addition to that, the soft-switching characteristics were also achieved. The MOSFET switches are turned on during zero voltage switching (ZVS) and the secondary output diodes are turned off during zero current switching (ZCS). Furthermore, when the relay switch was closed, the output voltage was twice higher than that when the relay switch was open. This means that smaller current are flowing through the output diodes, output capacitor and transformer, which leads to reducing the stress on these components and potentially increasing their operating lifespan.

# CHAPTER ONE

## INTRODUCTION

### 1.1 Background and Motivation

Recently, due to the fast development in industry and the growth of population, the human needs for energy sources have been increasing. However, there is a need for conserving the environment from pollution, otherwise, the pollution affects the sustainability of sources negatively. Recently, the governments and societies are forced to find solutions for enhancing the sustainability, due to the widespread awareness of the sustainability problems around the world.

The main point is energy-saving, which can be achieved by using electrical power efficiently and properly. Therefore, many technologies are developed to reduce the consumption. Worldwide, the lighting applications of the residential, commercial and industrial use consume 20% of the electric power [1]. In the year 2001, the distribution of light sources was 0.08% of solid-state lamps, 2% of HID, 35% of fluorescent lamps and 63% of incandescent lamps [1]. Researchers find that the percentage of incandescent lamps in residential and commercial buildings are still 63%; which come as the worst type in power losses, oldest and lowest in terms of efficient technology of lighting. There are two methods to save energy, one depends on the technology development while the other depends on efficiency values [1]. The light-emitting diode (LED) is considered one of the recent famous technologies that lead to saving energy. The research project in this thesis proposes a new topology which is suitable for LED drivers. The variable output voltage is considered the main features of

the proposed topology. Some secondary features such as enhancement of the power factor, the total harmonic distortion, and the efficiency are achieved too. These merits help and encourage to increase the use of LED lights in industry fields and all locations, such as buildings and street lights.

In 1962, Jr. Nick Holonyak invented the first LED (light-emitting diode), also called SSL (solid state lighting), which was the first practical product displayed and has a red light. After inventing the first blue LED in 1990 by Shuji Nakamura it became possible to create a pure white LED, by integrated the blue light with red and green colors [2]. It has multiple advantages such as small size without considering tubes or filaments, environmentally friendly, low energy consumption, free from hazardous materials such as mercury, high efficiency and high lifespan between 100,000 - 35,000 hours (approximately 24 of working years) [3]. Luminous flux for oldest lamps of the red LED was 0.001 lm/w, which has evolved until recently reached to 100 lm/w [4]. In 2010, Cree said he could get 200 lm/w [5], which is an indicator for an incoming light revolution of LED lamps. For this reason, multiple of researchers are focused on this type of light.

## **1.2 Luminous Light Technology Development**

Before reaching to LED technology which considered the scientific revolution in the light world, there were some types of light technologies. These are mentioned, according to the following historical sequence as follow.

### **1.2.1 Incandescent Lamps**

In 1879, the first incandescent lamp was invented by Thomas Edison, which had a name of “electric lamp”. The improvement of the electric lamp with regard to the performance, the manufacturing capability and the lifetime continued until 1936. The number of times of turning on for the incandescent lamp has no effect on its lifespan. Some of the advantages of this type can be briefly summarized as; very simple, create comfortable lighting, operate over a wide range of temperatures and inexpensive, Where when the temperature of the environment is low, this leading to decreasing dramatically for the light output and efficiency of fluorescent fixtures [6].

### **1.2.2 Fluorescent Lamps**

In 1938, fluorescent lamps were produced. It uses the electrical arc to excite the gas electrons between the cathodes in order to produce the light. It uses the phosphor coating tubes to convert the light color to white. Compared to incandescent lamps, it has a long lifespan and more power efficiency. As a result, it is widely used. On the other hand, it has one disadvantage which is the negative impact of the cold weather [7].

### **1.2.3 Tungsten Halogen Lamps**

At the end of the 1950s, tungsten halogen lamps are invented as a result of the development of the incandescent lamps. Although it has some advantages, it was not used until the end of the 1980s. The lamp contains a tungsten filament and a halogen gas, and it has a temperatures wall which is higher than the standard criteria of the incandescent lamps [6].



### 1.2.4 High-Intensity Discharge Lamps

In the 1960s, high-intensity discharge lamps (HID) were invented, which has similar principle work to the fluorescent lamps. The arc is generated between two electrodes. The HID lamps are well suited to specific applications. It has a long lifespan and generates a large quantity of light, pressure, and heat within the arc cover, although the arc is shorter than the arc of the fluorescents lamp. Recently, some newer types of low-power HID sources appeared in the markets which have high efficacy such as mercury vapor, high-pressure sodium, and metal halide lamps [6].

### 1.3 Light-Emitting Diode (LED) Technology

The LED has two description names: “high-brightness” and “illumination-grade”. It has a very quick improvement with respect to the luminous feature. Therefore, it is expected to exceed all the traditional lighting in the future. The LED technology is considered a smart solution for energy saving, although it is the most expensive price currently, but with fewer maintenance requirements. The studies indicate that this technology has a strong chance to be more prevalent in the future. Observed from Figure 1.1, the efficiency is increasing with time, although the price of LED is decreasing [8].

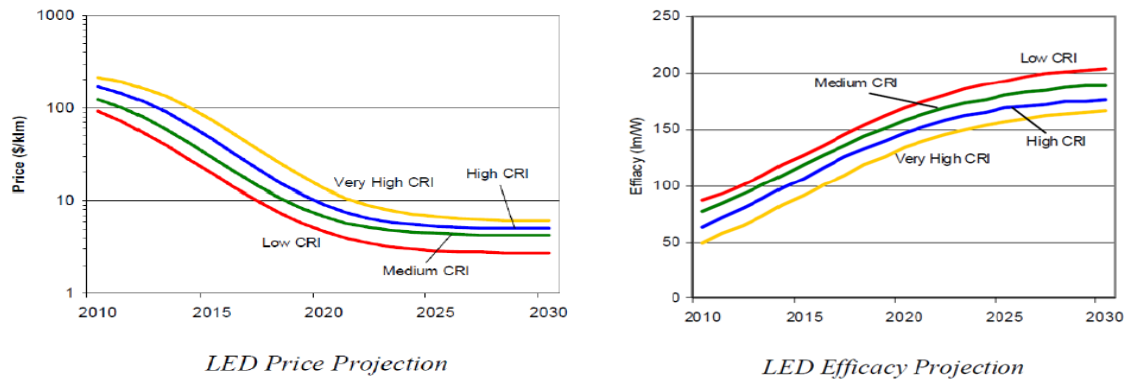

Figure 1.1 Price and efficiency projection for LED technology [8].

The advantages of incandescent lamps are low initial cost and reasonable color rendering, while the drawbacks are short life spans and very low efficiency. Compared with halogen lamps, it needs more power (watt) to result the same lumens output. It converts 10 % of the consumed energy to light while the rest is considered as heat loss. In the end, short lifespan and low efficiency which is nothing compared with LED performance which is considered much better [9]. Table 1.1 displays a comparison between all previous lighting technology types.

Table 1.1 Lighting technology comparison [9].

Light technology	Lumens per watt	Lifespan(hours)	Ignition time	Color rendering index(CRI)	Considerations
Incandescent light	11 - 15	1,000 -5,000	instant	40	short life time, very inefficient
Metal halide light	60 - 100	10,000 - 15,000	up to 15 min	80	risk of bursting at the end of life, contains mercury and lead
Mercury vapor light	13 - 48	12,000 - 24,000	up to 15 min	15 – 55	ultraviolet radiation, very inefficient, contains mercury
Fluorescent light	60 - 100	10,000 - 20,000	up to 15 min	70 – 90	contains mercury, UV radiation, diffused non-directional light
Compact fluorescent light	50 - 72	12,000 - 20,000	up to 15 min	85	contains mercury, low Lifespan

High pressure sodium light	45 - 130	12.000 - 24.000	up to 15 min	25	contains mercury and lead, low CRI with yellow light
LED light	70 - 150	50,000 - 100,000	instant	85 - 90	higher initial cost

#### 1.4 Problem Statement

The light emitting diode (LED) has increasingly become more popular compared to the traditional lights, due to the demands of more efficient energy usage and rapid developments of materials and technologies in solid-state lighting. The LED is suitable for indoor and outdoor lighting applications because of their remarkable features such as energy saving, long lifespan, good luminous efficacy and low maintenance costs [4]. The power factor correction (PFC) and LLC resonant circuit techniques are usually enforced to improve these features, as they are explained in the next chapter.

The LED driver can be classified into single-stage, two-stage and other multi-stage based on the number of stages employed in the topology architecture. Based on pulse-width modulation, many kinds of single-stage LED driver are well documented in the next chapter, such as the buck, boost, flyback and integrated buck-boost topologies. Compared with the two-stage, the single-stage LED driver is considered more suitable for low and medium power applications because it can reduce the component count, size, and cost. On the other hand, it has some drawbacks such as higher bus voltage ( $V_{bus}$ ) for the light load, more switching losses at higher input voltage state [10]. The

LED lamps need a feed source as DC voltage and current, however, the power grid source comes as AC voltage and current.

In this thesis, a single-stage topology is proposed to overcome those problems and enhance the power factor, efficiency, lifetime and total harmonic distortion. Meanwhile, it reduces the cost, size, and complexity.

## **1.5 Research Objectives**

The main objectives of this research are:

- a) To propose a single-stage AC/DC converter with a variable output voltage, to be suitable for LED lighting applications.
- b) To evaluate the steady-state characteristics and performance of the proposed converter so that it has less complexity, cost and total harmonic distortion (THD), and high power factor (PF) and efficiency.
- c) To design and simulate the performance of the proposed converter using Matlab Simulink software.

## **1.6 Scope of Research Work**

The scope of this research is limited to a single-stage AC/DC converter and its new related techniques, such as the power factor correction (PFC) and LLC resonant. This research gives a clear summary for the earlier single stage AC/DC converter topologies. The DC/DC two boost converter is used in this research. This research work is implemented using MATLAB simulink software, without building the experimental prototype.

## **1.7 Research Contributions**

Two main contributions can be summarized as: Firstly, a single-stage dual output AC/DC converter with PFC is proposed. This proposed topology has the ability to reduce the stress on LED lamps and increase the lifespan for LED lamps. Moreover, it finds the appropriate values of the power factor, efficiency, and total harmonic distortion for the proposed single-stage AC/DC converter with a variable output voltage, that are suitable for LED lighting applications. The proposed converter is a combination of topologies in [11, 12], and [13]. The topology in [11, 12] is suitable for LED light with 100W, while the topology in [13] is suitable for charging a deeply depleted battery of electrical cars. In this research, the design and simulation of the performance of the proposed converter were done using MATLAB simulink software.

## **1.8 Thesis Outlines**

This thesis is comprised of five chapters, which are organized as follows: Chapter 1 consists of eight sections, that starts with the background and motivation which explains the reasons of the interest for this topic, and a historical introduction to the LED light applications and its evolution. Lastly, the problem statement, research objectives, scope of research work, research contributions and the thesis outlines are discussed to show the purpose of this study in brief.

Chapter 2 focuses on the literature review of LED drivers. It starts with the definition, structure and operating principle (for LED light). Then, the advantages (of LED), which are achieved by improving electrical characteristics of LED driver are discussed. After that, the components and technologies (such as Power Factor

Correction (PFC) and LLC Resonant Converter) of the single-Phase AC/DC converters are explained. Finally, the similar works of the proposed topologies which it is a suitable for LED light are briefly well documented.

In chapter 3, the research methodology is presented. Moreover, a single stage dual output AC/DC converter with PFC for supplying LED light is proposed to achieve the objectives of this thesis. The circuit configurations, analysis of steady state operation and gain characteristics of the proposed topology at two cases of the relay switch are presented and discussed in detail. Lastly, the design and simulation procedure of the proposed converter are explained.

Chapter 4 displays and discusses the waveforms obtained from the simulation model, The simulation results of the proposed converter when the relay switch is open and closed, and compare between two cases of the relay switch with the proposed in [11]. All the results were found using the MATLAB software.

Chapter 5 provides conclusions of this research. Furthermore, it gives some recommendations for future work based on the achievements of this research.

## **CHAPTER TWO**

### **LITERATURE REVIEW**

#### **2.1 Introduction**

Power electronics consist of semiconductor elements such as capacitor, inductor, and transistors, which are used to control and convert electric energy. The power electronics converters are widely used in industrial applications, such as light-emitting diode (LED) driver, telecom equipment, and electric vehicles (EV), where they work on conversion of the electrical energy of AC to DC, DC to AC or from DC level to another DC level. This chapter attempts to survey previous researches for single-phase single-stage AC/DC coupled with a DC/DC converter, and clarify all the contents of elements and converter circuits, such as power factor correction (PFC) circuits and LLC resonant converters, and their impact on power factor (PF), efficiency, and total harmonic distortion (THD), compare between single-stage and two-stage converters. This chapter will also explain the characteristics, advantages and disadvantages of all these topologies which were achieved by past researchers until now, which are considered suitable for LED drivers. The next section explains and clarifies the electrical characteristics, structure, operating principle and advantages of LED drivers.

#### **2.2 LED, Structure and Operating Principle**

When electrical energy flowing through LED, it is directly converted to light energy, compare with the traditional lamps which convert the electrical energy to heat energy. The atoms consist of neutrons, protons, and electrons, which releases some types of energy such as light. The light is composed of many photons. The electrons

which revolve around nucleus need some external energy so that they can move from lower level energy to higher level energy. The photons are created as the result of energy loss from electrons when they comeback from the higher level to lower level of energy. Figure 2.1 displays the atom components, where E1 is lower energy level and E3 is higher energy level [4, 14].

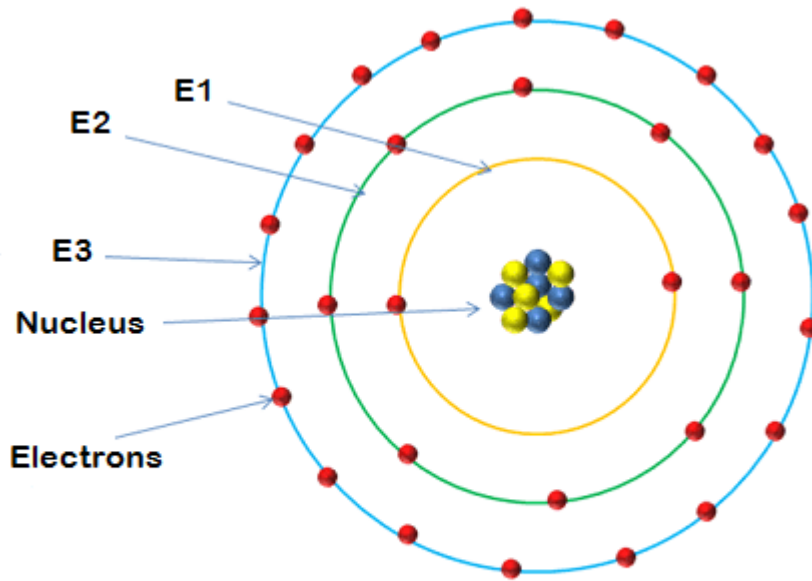

Figure 2.1 The atom components [14].

LEDs are electronic devices consisting of a chip that works like a semiconductor diode. When LED is forward biased, the electricity flows in the "p-n junction" from a positive side (anode) to a negative side (cathode), then this electrical energy is converted inside "p-n junction" to light energy. In other words, the process of reintegrating the free electrons with holes and its rearrangement, will produce photons that shine on LED



surface as light, as seen in Figure 2.2. But in the case of a reverse bias, electricity is not flowing through the "p-n junction". So the 'p-n junction' works only in one direction.

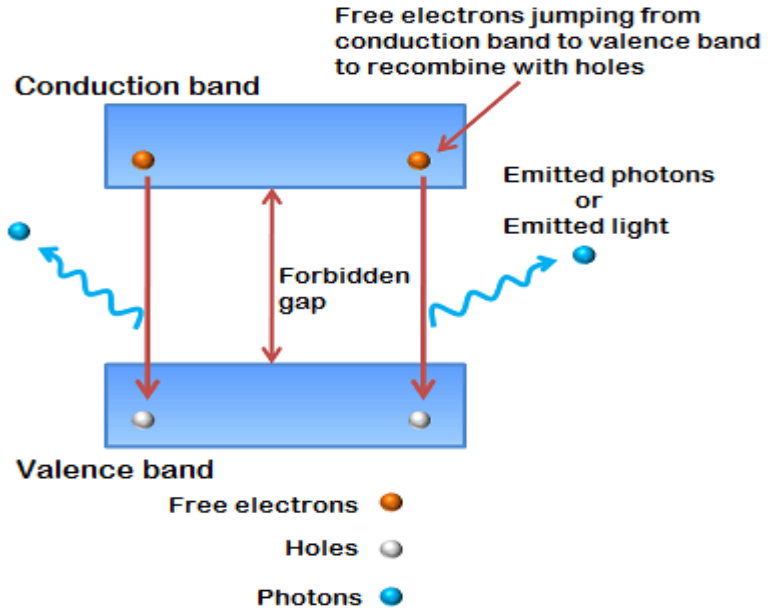
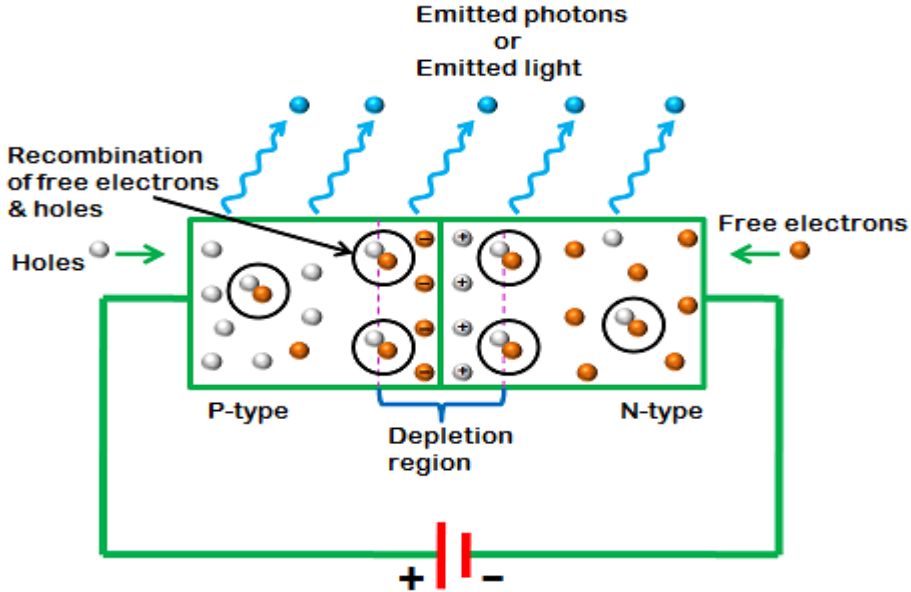

Figure 2.2 LED operating principle [14].

Germanium or silicon materials are used in diodes industry, however despite their advantages, they are not used for building LED because they do not release energy in the form of light but as heat. For building LED, gallium, arsenic and phosphorus materials are used [14]. Conversion efficiency for LED depends on the emitting wavelength, which depends on the band gap structure and materials. Wavelength affects the types of light extracted from LED, where can it be ultraviolet, infrared or variety of visible colors.

### **2.3 Advantages of LED**

There are multiple advantages of LED light that have made it a favorite in use compared to traditional lights such as higher efficiency, higher power factor and lower harmonic distortion. The following subsections describe the advantages of using LEDs.

#### **2.3.1 Higher Efficiency**

The energy conversion efficiency is the measurable ratio of output energy to the input energy.

$$\text{energy conversion efficiency} = \frac{\text{Useful energy output}}{\text{Energy input}}$$

The meaning of the word 'useful' in the above formula is the output energy used to achieve the goal. For example, the heat is considered output energy but not useful and on antithesis it negatively affects the product, for this it must be eliminated [15]. The best value of efficiency is unity or 100%, the heat is a key factor to reduce efficiency. The LED lamps have energy efficiency 7 times more than incandescent and twice of fluorescent lamps. Also, it uses 40-80% less electricity when used in street lights [14].

### **2.3.2 Higher Power Factor**

Power factor is the ratio of active power (Watts) to the apparent power (VA). The best value for power factor (PF) is 1, when the PF is less than that, this means the system has losses, which affects the demand on the power grid, reduce efficiency and lifespan, and increases cost on consumer [16]. High power factor can be achieved for LED driver.

### **2.3.3 Lower Harmonic Distortion**

Harmonics are sinusoidal components of voltage or current those have frequencies of multiple fundamental frequency, the sum of all components in one shape is called Total Harmonic Distortion (THD) compared with the fundamental component. The lower the THD value is, the better, which means higher efficiency, higher power factor and lower peak currents [17]. There is a relationship between total harmonic distortion (THD) and power factor (PF) where  $(THD = 1 - PF^2)$ , so any adjustment on one value will have an affect the other value, then the system as a whole. Solving the problem of Total Harmonic Distortion (THD) for LED is not easy. THD has an effect on other associated systems within the building, this is one of the reasons which makes minimizing THD value more important than maximizing PF value. Enhancement of the THD must be for each single load, to minimize its impact on other systems. For loads under 25W, it is more important to enhance THD than PF, but for larger loads, a  $PF > 0.9$ ,  $THD < 20\%$  and efficiency  $>85\%$  is preferred, because this has a greater impact on the grid [16].

### 2.3.4 Longer Life Span

One of the most important features of LED is longer life span compared to other types of Light technology. It has an approximate life-time between 50,000 - 100,000 hours, in perfect conditions, when the internal chip is at a cold temperature, the best value of hours is achieved [18]. LED has life-time 5 times larger than that of fluorescent lamps, and 50 times than that of incandescent lamps, see Table 1.1. The longer lifespan of LED is suitable for some locations where it is difficult to reach and have higher maintenance costs such as street lights [9]. Figure 2.3 shows the relationship between lumen output (%) and operation time (k hrs) for different types of light technology [19].

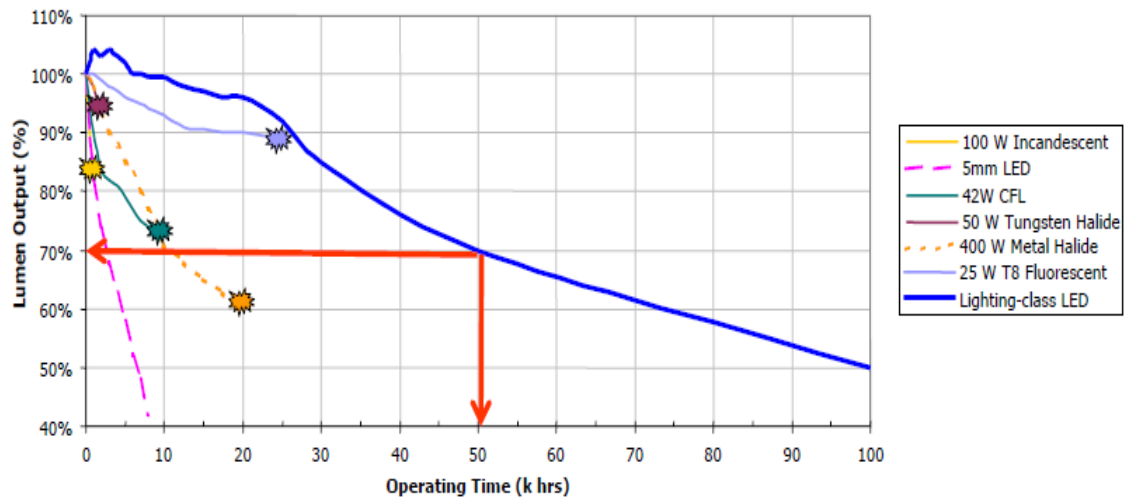

Figure 2.3 Relationship between lumen output and operation time for different types of light technology [19].

### **2.3.5 Other Features**

Many other features exist in LED lights such as less energy consumption, great operating characteristics where it is unaffected by lower temperatures, reducing pollution and environmental friendliness, easily controllable and flicker-lighting is less. The flicker-lighting is fluctuation in the brightness, which have effects on human health such as headaches, malaise and visual impairment. It can be disposed of by exposing the LED to a constant current [9, 18, 20].

## **2.4 Electrical Characteristics of LED Driver**

The LEDs have a set of properties fairly close to the characteristics of the diode, which will be explained in this section. The LEDs work on a DC source in a forward bias direction, which is taken directly from the battery or AC/DC converter circuit. It has force relationship between the forward voltage  $V_F$  with current flowing through it and the junction temperature. The previous characteristics directly control the emitted light quantity. Therefore, it is necessary to focus on studying these characteristics and understanding the principle operation for easier control and getting the best results [4, 21].

### **2.4.1 Forward Voltage and Current**

The V-I curve for LED is similar to that of standard diodes. It can be noted from Figure 2.4 that the current starts flowing through LED when threshold voltage at 2.7 V is achieved, after reaching the threshold voltage, the current starts rapidly increasing with small voltage increase since the relationship between them is exponential. The large current variation leads to a large variation in light quantity emitted from LED. Due to previous behavior, the LEDs require a constant voltage and current [4, 21].

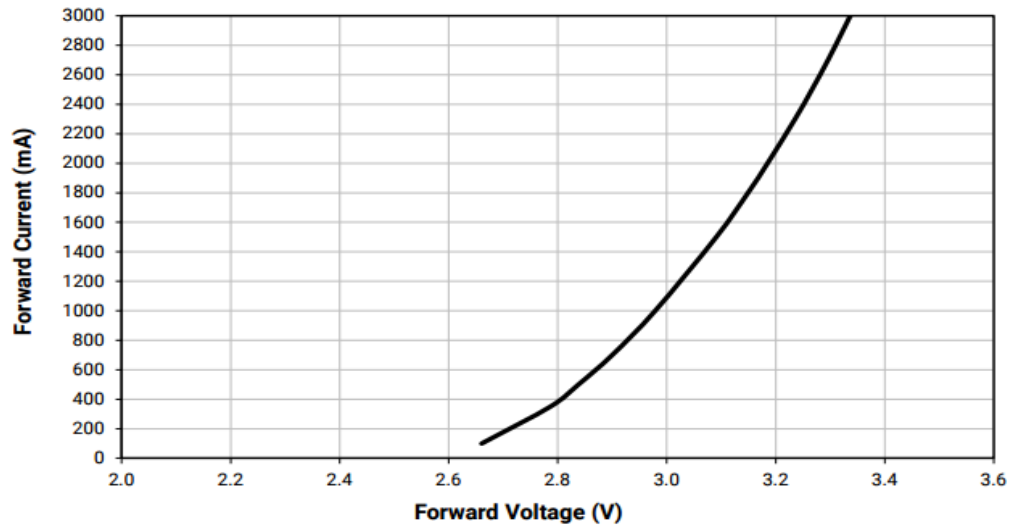

Figure 2.4 Relationship between forward voltage with forward current [22].

The amount of the light output from LEDs depends mainly on LED current, when the current is increasing the light is increasing. The LED current also has effects on forward voltage, colors or wavelength shift, luminous flux and efficiency for LED, which finally has an impact on system efficiency. Figure 2.5 shows the relationship between relative flux (luminous) and efficiency with forward current. It is observed that when the feeding current for LED is increasing, the luminous flux is increasing also, and at the same time, whenever the current is increasing the efficiency will adversely be affected by the decreasing. The efficiency is expressed as number of lumens per watt [4, 21].

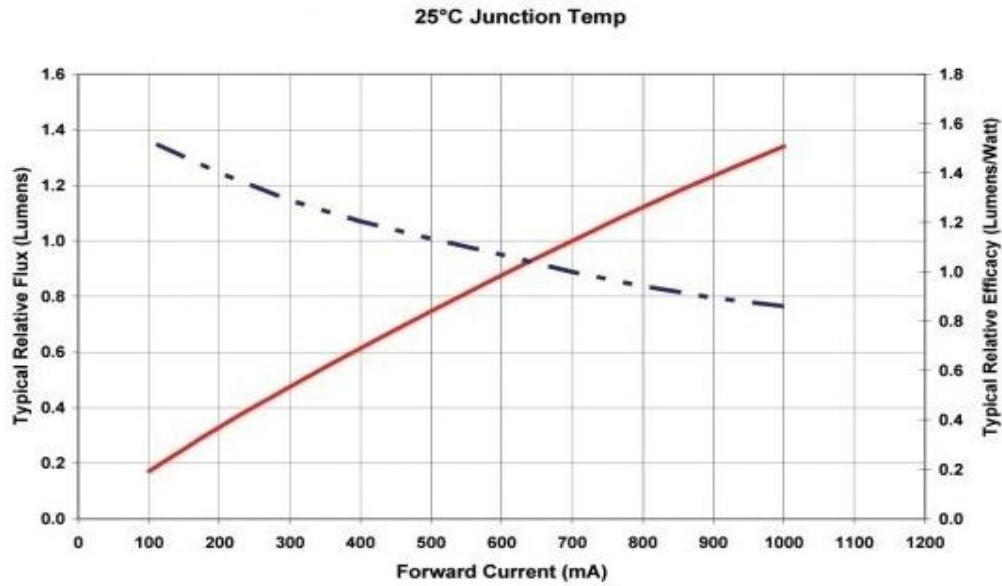

Figure 2.5 Relationship between relative flux and efficacy with forward current [23].

LED cannot work in reverse biased, and should be protected from voltages or currents which exceed the limit, otherwise the LED is going to fail.

### 2.4.2 Junction Temperature

The junction temperature ( $T_j$ ) of the LED lamps is set at 25°C. However, most LED operate well above it, for this the previous value is taken as reference only. Higher LED junction temperatures may occur due to increased power dissipation or changing in environment temperature. Whenever junction temperatures are increasing continuously more than the standard limit, most of the performance characteristics for LED light will be decreasing such as light output, lifespan, luminous flux ( $\Phi_v$ ) and forward voltage ( $\Delta V_f$ ) as seen in Figure 2.6.a, for high power LED, the drawbacks become larger [21, 23].

In Figure 2.6.b, the increase in junction temperature leads to a decrease in flux, this can be compensated with LED current, but any change in current will have effects on other electrical parameters. For this, the junction temperature is taken into consideration [21, 23].

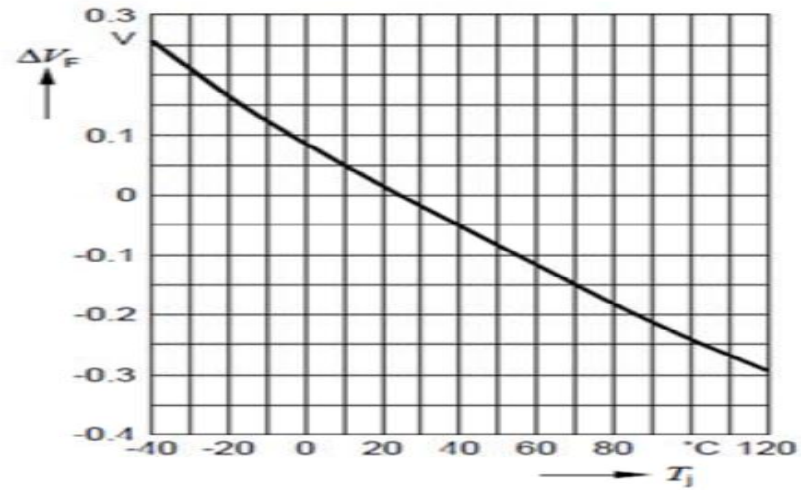

(A)

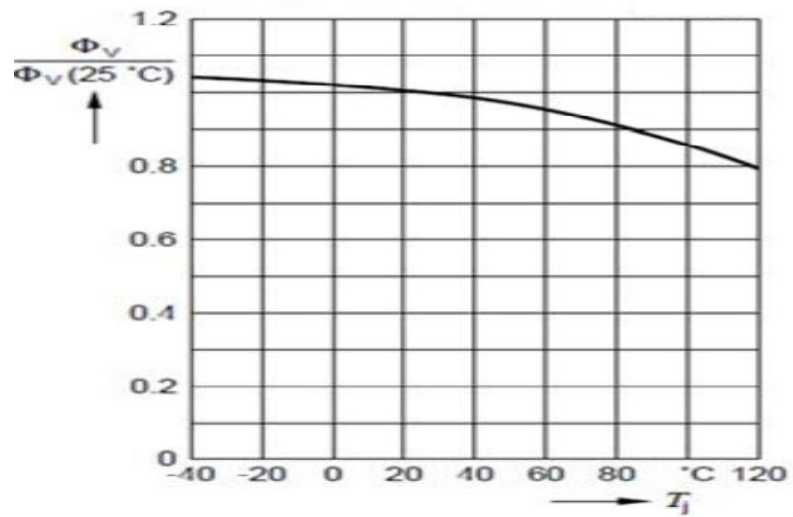

(B)

Figure 2.6 (A) Impact of junction temperatures ( $T_j$ ) on voltage forward ( $\Delta V_f$ ). (B) Impact of junction temperatures on luminous flux ( $\Phi_v$ ) [21].



## **2.5 Single-Phase AC/DC Converters for LED Driver**

The power grid provides electrical AC supply to electrical equipment and devices at rated frequency of 50 or 60 Hz, depending on the country. Grid AC voltage levels are also different from country to another such as the US which uses low voltage 110 Vac and Europe which uses high voltage 220 Vac, however in Malaysia 240 Vac and 50 Hz are used. Some electronic devices cannot use the AC voltage directly, but it needs DC current and voltage. DC is a one-way flowing of electricity which can be obtained directly from batteries or from an AC source but by using AC/DC converters.

There are two types of traditional AC/DC converters, controlled and uncontrolled rectifiers. Uncontrolled full-wave rectifiers are used in this thesis, which works on converting the input voltage from AC to DC with retention of the same magnitude and reversing the negative half of the waveform to positive as seen from Figure 2.7. Uncontrolled rectifiers consist of diode only, unlike the controlled rectifiers which consist of diodes and controlled devices such as thyristors and MOSFETs [24]. Recently, switch-mode power converters became popular in the industrial, commercial, residential and aerospace because of the advantages of high efficiency, smaller weight and size [25].

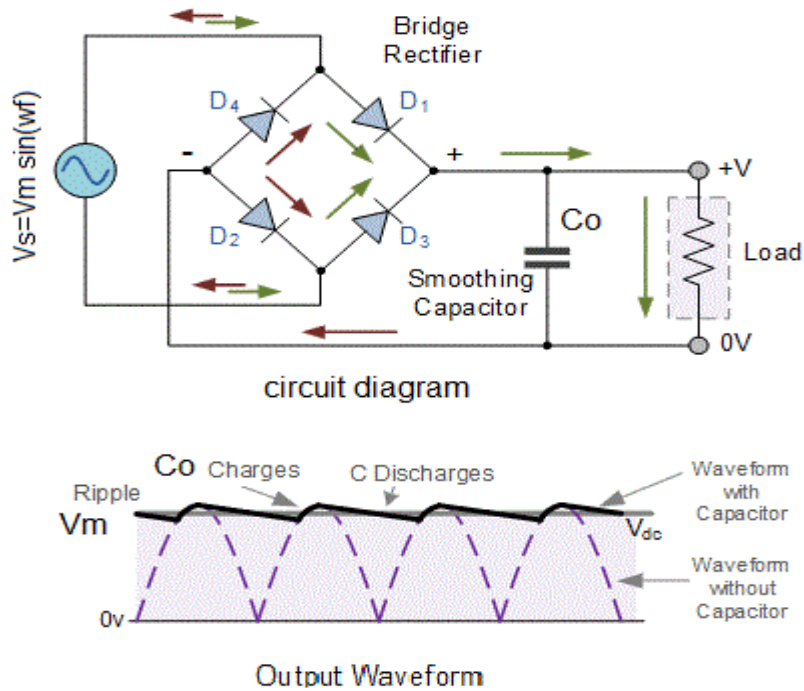

Figure 2.7 Uncontrolled AC/DC full-wave rectifier [26].

Noted from circuit diagram in Figure 2.7, the output voltage is DC but not entirely (without capacitor), where the output voltage is changing between 0 to maximum voltage ( $V_m$ ). To improve this, we can add a capacitor ( $C_o$ ) in parallel with the loads as seen in Figure 2.7. The output voltage is improved but also not entirely. The LED driver requires the constant voltage and current to be at a certain value to achieve a low THD and high PF as explained previously, because of this, we need some new techniques to get better results. Examples of these techniques are the power factor correction (PFC) and LLC resonant.

### **2.5.1 Power Factor Correction**

Power factor is a measured value of the energy efficiency used by the equipment. This value is influenced by the phase shift between current and voltage and input harmonics. The  $(\cos \phi)$  is not used to calculate the Power factor (PF), unless current and voltage are perfectly sinusoidal signals. The expansion of the power converters draws pulsating input current from the utility line, thus reducing the power factor and increasing the current total harmonic distortion of the converters [27]. To eliminate or at least reduce harmonic current and improve the overall system power factor, there are several methods of power factor correction (PFC), which can be classified as:

- i. Passive power factor correction methods.
- ii. Active power factor correction methods.

#### **2.5.1.1 Passive Power Factor Correction**

Passive power factor correction methods have advantages such as; simplicity, no switching losses, reliability, no emission of electromagnetic interference and being the most direct methods to reduce input current harmonics. Despite this, it is considered lower in effectiveness compared to active power factor correction, and it is dependent on load variations. A passive circuit consisting of LC filter which can be inserted either at the input or at the output side of the diode rectifier of AC/DC converter, as shown in Figure 2.8.

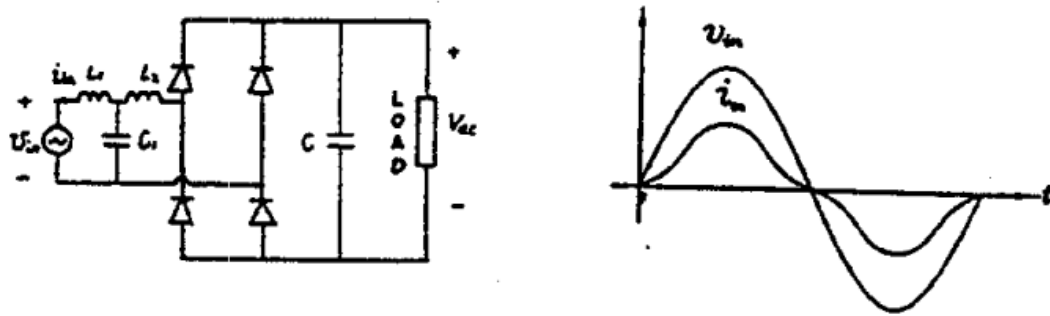

Figure 2.8 Passive PFC method [27].

There are several advantages for this method such as simplicity, low EMI and high efficiency. But the main drawback is that it makes the converter bulky and heavy [27].

### 2.5.1.2 Active Power Factor Correction

The power factor could reach up to unity in active power factor correction methods by using the switched-mode power supply (SMPS) method, which is used to shape the input current to be in phase with the input voltage. The active PFC consists of a single transistor or more, which are used in a bridge configuration. This transistor works as an on/off switch. The building process of the active PFC system is more intricate than passive PFC system and requires the use of specialized combined circuits. For example, active power factor correction systems are integrated between AC/DC converters with the load directly in series, or with another conversion system DC/AC or DC/DC converter. Basically, the Buck (step-down), Boost (step-up), and Buck-Boost (step-up/down) converters are used in building AC/DC converters with active PFC function. The Boost converter (step-up) is considered the most famous. The MOSFET transistors and the IGBTs are used for smaller power and larger capacity, respectively. Recently, there are multiple types of topologies are used to implementing active power

factor correction methods. Figure 2.9 shows the circuit diagram of a basic active power correction method, where the input current in phase with the input voltage.

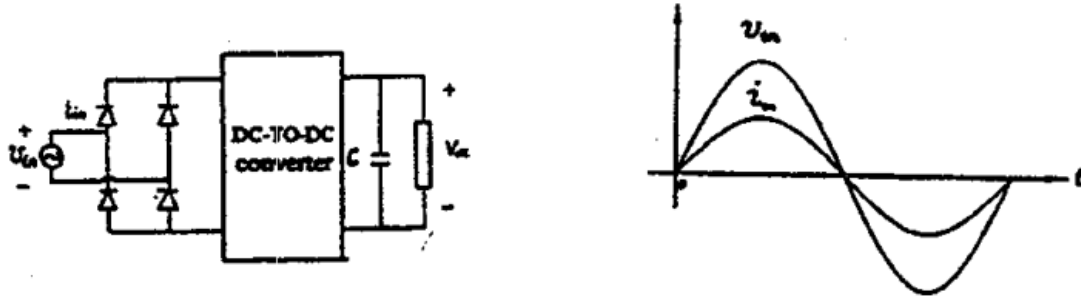

Figure 2.9 Active PFC method and waveform of the input current and voltage [27].

The active PFC method has many advantages adding to the advantages of the passive PFC such as reduced harmonics, high power factor, smaller converter size and light-weight. But the main disadvantages of this method are the complexity and having a relatively higher cost [25]. Whereas the passive methods are perhaps the best choice in many low-power, cost sensitive applications; the active PFC methods are used in the majority of applications due to their topmost performance [28].

There are two methods of operation modes for PFC applications; continuous conduction mode (CCM) and discontinuous conduction mode (DCM), which are used widely in power electronics equipment. When the current flows through inductor throughout the switching period continuously and never reaches to zero value, this means that continuous conduction mode (CCM) method is used (always current  $>0$ ), but when the current through it reaches to zero value during switching period, this means discontinuous conduction mode (DCM) method is used [29]. A DC/DC switching converter uses both CCM and DCM methods widely. For high-power applications, the