

AUTOMATED CORE AND CAVITY DESIGN
SYSTEM FOR MOULD WORKS USING
GENERATIVE METHOD OF COMPUTER AIDED
PROCESS PLANNING

MURSYIDAH BINTI MD YUSOF

UNIVERSITI SAINS MALAYSIA

2017

**AUTOMATED CORE AND CAVITY DESIGN SYSTEM FOR
MOULD WORKS USING GENERATIVE METHOD OF
COMPUTER AIDED PROCESS PLANNING**

by

MURSYIDAH BINTI MD YUSOF

**Thesis submitted in fulfillment of the
requirements for the Degree
of Master of Science**

July 2017

ACKNOWLEDGEMENTS

In the name of Allah, the Most Gracious and Most Merciful.

Alhamdulillah, all praises be to Allah for His Blessings in allowing me to complete my thesis writing and thus finish my master's study.

I would like to express my gratitude towards Dr.Mohd Salman Abu Mansor as my supervisor for his help and guidance throughout this journey. I am very grateful to my parents who have supported me financially and emotionally from the first day to the final day of my master's study. Not to forget, I am very thankful to Encik Baharom as the laboratory technician who also helped me on the technical issues in the laboratory, and also to the previous and current master and PhD students in the research group, who strived together in this journey.

I would also like to thank all my previous lecturers during foundation and degree who have given me the knowledge and understanding especially the subjects that are much related in my research. Much gratitude is given to my family and friends who gave me strength and support to finish my study.

Appreciation is given to Universiti Sains Malaysia for allowing me to gain experience and knowledge in this research and study the topic which is in my interest. It helps me to widen my knowledge and deepen my understanding.

Mursyidah Md Yusof

July, 2017

TABLE OF CONTENTS

	Page
ACKNOWLEDGMENTS	ii
TABLE OF CONTENTS	iii
LIST OF TABLES	vi
LIST OF FIGURES	vii
LIST OF SYMBOLS	x
LIST OF ABBREVIATIONS	xii
ABSTRAK	xiii
ABSTRACT	xiv
CHAPTER ONE: INTRODUCTION	
1.1 Background of Study	1
1.2 Problem Statement	3
1.3 Aim and Objectives of The Research	3
1.4 Scope of Study	4
1.5 Research Approach	5
1.6 Organization of Thesis	5
CHAPTER TWO: LITERATURE REVIEW	
2.1 Manufacturing Technology	7
2.2 CAPP	8
2.3 Injection Moulding	11
2.4 Moulding Unit	11
2.5 Mould Machining	16

2.6	CADIMDS	18
2.7	Parting Direction	20
2.8	AFR	21
2.8.1	Undercut Feature Recognition	22
2.8.2	Geometrical Method	22
2.8.3	Graph Based Method	24
2.8.4	Volume Based Method	24
2.8.5	Other Methods	25
2.8.6	Visibility Map	25
2.8.7	Volume Discretization	27
2.9	Criteria and Weights	28
2.10	Parting Line	29
2.11	Parting Surface	31
2.12	Side-core Design	31
2.13	Summary	32

CHAPTER THREE: METHODOLOGY

3.1	ACCDS	34
3.2	V-map and BE	37
3.3	Sub-process 1– BE and Parting Direction Generation	41
3.3.1	Face Recognition and Surface Area	42
3.3.2	Generating BE for a Face	44
3.3.3	Sub-process 1.1– Intersection of Two BE	45
3.3.4	Face Grouping and BE of a Group	48
3.3.5	Parting Direction	52
3.4	Sub-process 2 – Side-core Generation	54

3.4.1	Undercuts and Side-cores	54
3.5	Sub-process 3– Core and Cavity Generation	56
3.5.1	Parting Lines and Parting Surfaces	57
3.5.2	Hole Solids	58
3.5.3	Side-cores for Through Hole Undercut	58
3.5.4	Core and Cavity Generation	59
3.5.5	Tool Position Range Generation	60

CHAPTER FOUR: RESULT AND DISCUSSION

4.1	Case Study 1	62
4.2	Case Study 2	75

CHAPTER FIVE: CONCLUSION

5.1	Conclusion	85
5.2	Contribution	86
5.3	Recommendations	86

REFERENCES	87
-------------------	----

APPENDICES

APPENDIX A: The γ angles for BEs of core and cavity for case study 1

APPENDIX B: The γ angles for BEs of core and cavity for case study 2

LIST OF JOURNALS AND CONFERENCES

LIST OF TABLES

		Page
Table 4.1	Value of γ_0 to γ_{19} between L_{i-1} and L_i	73
Table 4.2	Value of β_0 to β_{19} between L and M_j	74
Table 4.3	Value of β_0 to β_{19} between L and M_k	75

LIST OF FIGURES

	Page
Figure 2.1	11
Figure 2.2	12
Figure 2.3	15
Figure 2.4	15
Figure 2.5	16
Figure 2.6	19
Figure 2.7	26
Figure 3.1	34
Figure 3.2	35
Figure 3.3	38
Figure 3.4	38
Figure 3.5	39
Figure 3.6	40
Figure 3.7	41
Figure 3.8	41
Figure 3.9	43
Figure 3.10	44
Figure 3.11	45
Figure 3.12	45
Figure 3.13	49
Figure 3.14	50
Figure 3.15	52
Figure 3.16	53
Figure 3.17	54

Figure 3.18	External side-core (a) BE before parallel test (b) BE after parallel test	55
Figure 3.19	Sub-process 3 flowchart	56
Figure 3.20	Outer and inner parting line	57
Figure 3.21	Outer and inner parting surface	57
Figure 3.22	Creating hole solid (a) original body (b) filled body (c) hole solid	58
Figure 3.23	Side-core generation	59
Figure 3.24	Two-plate mould	60
Figure 4.1	Plastic Strainer in isometric view	62
Figure 4.2	Free-form faces with their BE	63
Figure 4.3	Free-form and planar faces with their BE	64
Figure 4.4	Hole groups and their BE	65
Figure 4.5	Intersection of BE face 114 to 117 resulting BE for group H_0	65
Figure 4.6	Final face groups (a) Y_0 (b) BE for Y_0 (c) Y_1 (d) BE for Y_1 (e) Y_2 (e) BE for Y_2	66
Figure 4.7	Parting direction of core, cavity and side-core	67
Figure 4.8	Generated parting elements (a) parting line and (b) parting surface	68
Figure 4.9	Generated solids (a) hole solids and (b) side-core	68
Figure 4.10	Generated solids (a) core and (b) cavity	68
Figure 4.11	Exploded view of core, cavity and side-core	69
Figure 4.12	Tool position range for faces of core (a) bottom part (b) top part	70
Figure 4.13	Tool position range for faces of cavity	71
Figure 4.14	Tool position range on tool path AB at face 126	71
Figure 4.15	Direction vectors of L , M_j and M_k (top view)	73
Figure 4.16	Plug part (a) isometric view (b) wireframe view	76
Figure 4.17	Random faces with their BE	76
Figure 4.18	Face groups (a) Y_0 , (b) Y_1 , (c) Y_2 , Y_3 , (d) Y_4 , Y_5 and Y_6	77
Figure 4.19	BE for Y groups	77

Figure 4.20	Final face groups (a) Y_0 , (b) Y_1 , (c) Y_2, Y_3 , (d) Y_4 and Y_5	78
Figure 4.21	BE for final face groups	78
Figure 4.22	Side-cores	79
Figure 4.23	Generated parting elements (a) parting line and parting surface	80
Figure 4.24	Generated solids (a) core and (b) cavity	80
Figure 4.25	Side-cores inside cavity mould	81
Figure 4.26	Exploded view of core, cavity and side-cores	81
Figure 4.27	Tool position range (a) core and (b) cavity	82
Figure 4.28	Output generated by Lin and Quang (2014)	84

LIST OF SYMBOLS

$+p_d$	Positive Parting direction
$-p_d$	Negative Parting direction
$+p_s$	Positive Side direction
$-p_s$	Negative Side direction
a	Area
A	Set of entities
B	Set of entities
D	Direction vector
De	Direction Unit vector
D_x	Random direction vector
D_x	Tool's centre axis at a random direction vector
D_f	Range of D for face shaped BE
D_s	Range of D for solid shaped BE
E	Edge
E_f	Number of edges in a face
E_{uv}	Number of U lines and V lines
F	Face
H	Hole or non-convex face group
H_s	Hole solid
l	Length
l_b	Length of segmented box on a face
L	Line
L	Direction vector between D and D_i
M	Mould piece
M	Direction vector between D and D_x
N_f	Normal vector of a face
N_{pf}	Normal vector of flat circle
O_f	Origin at a face
p_d	Parting direction
S	Solid

Sp	Number of surface points for a face
P	Surface point
T	Total number of BE
Ud	Undercut direction
U_f	U vector of a face
U_{pf}	U vector of flat circle
U_f	Undercut
V_f	V vector of a face
V_{pf}	V vector of flat circle
w_b	Width of segmented box on a face
V	Vertex
v	Volume
Y	Final face group

Mathematical Symbols

\cdot	Dot product
$>$	More than
$<$	Less than
\neq	Does not equal to
\cap	Intersection
\cup	Union

Greek Letters

β	Angle between L_a and L_b
γ	Angle between L and M
θ	Angle between D_1 and D_2
α	Angle between D_1 and D_x

LIST OF ABBREVIATIONS

2D	2 dimension
3D	3 dimension
6D	6 dimension
ACCDS	Automated core and cavity design system
AFR	Automatic feature recognition
BE	B-rep entity
BEF	BE of a face
BEH	BE of a hole or non-convex face group
BEJ	BE of an intermediate face group
BER	Intersection result of two BE
BEY	BE of a final face group
B-rep	Boundary Representation
CAD	Computer-aided design
CADIMDS	Computer-aided injection mould design system
CAM	Computer-aided manufacturing
CAPP	Computer-aided process planning
CNC	Computer numerical control
EFAAG	Extended Face Adjacency Attribute Graph
FAAG	Face Adjacency Attribute Graph
GT	Group technology
GVM	Global V-map
IOT	Internet-of-things
LVM	local V-map
MPMA	Malaysian Plastics Manufacturers Association
NC	Numerical control
PLR	Parting line region
PMT	Parallel machine tool
V-map	Visibility map

**SISTEM REKABENTUK TERAS DAN RONGGA AUTOMATIK BAGI
PENYEDIAAN PERKAKASAN ACUAN MENGGUNAKAN KAEDAH
PENGHASILAN PERANCANGAN PROSES BERBANTUKAN KOMPUTER**

ABSTRAK

Sejak beberapa tahun kebelakangan ini, pelbagai usaha telah dilakukan untuk menjadikan aktiviti merekabentuk teras dan rongga menjadi automatik sepenuhnya. Tiga kekurangan ketara dalam sistem rekabentuk teras dan rongga automatik sebelum ini adalah (i) arah pemisah yang kurang fleksibel, (ii) ketidakupayaan untuk mengesan dan menjana arah pemisah untuk kedua-dua *undercut* dalaman dan luaran dan (iii) tiada pemindahan maklumat daripada sistem rekabentuk teras dan rongga automatik ke sistem pemesinan. Bagi mengatasi kekurangan ini, sistem rekabentuk teras dan rongga automatik (ACCDS) dihasilkan. Sistem ini bertindak sebagai satu komponen dalam sistem perancangan proses berbantuan komputer di mana ia mengambil maklumat daripada mana-mana model 3D CAD dan menyediakan maklumat kepada sistem pemesinan acuan. Kaedah penghasilan adalah asas kepada sistem ini di mana model teras dan rongga dihasilkan dari awal. Hasil yang dikeluarkan daripada sistem ini adalah (i) teras, rongga dan teras-sisi bersama arah pemisah acuan dan (ii) maklumat julat sudut bagi sifar perlanggaran antara mata alat dan permukaan bahagian acuan teras dan rongga. Dengan membandingkan ACCDS dengan sistem terkini yang telah dicadangkan oleh seorang penyelidik, penambahbaikan seperti rekabentuk teras dan rongga yang lebih baik dan pengurangan masa sistem komputer dapat diperhatikan. Ini menunjukkan bahawa ACCDS berjaya menyumbang dalam perbaikan sistem rekabentuk teras dan rongga secara automatik.

**AUTOMATED CORE AND CAVITY DESIGN SYSTEM FOR MOULD
WORKS USING GENERATIVE METHOD OF COMPUTER AIDED
PROCESS PLANNING**

ABSTRACT

In recent years, many efforts have been made for core and cavity design system to be fully automated. Three profound limitations in the previous automated core and cavity design systems are (i) the lack in parting direction flexibility, (ii) inability to detect and generate parting direction for both inner and outer undercuts and (iii) no information transfer from automated core and cavity design system to machining system. To overcome these limitations, automated core and cavity design system (ACCDS) is developed. This system acts as a component in computer aided process planning system where it takes information from any 3D CAD model and provides information to the machining system. Generative method is the basis of this system where core and cavity models are generated from scratch. The outputs from the system are (i) the generated core, cavity and side-cores with parting direction and (ii) the information of zero tool-face collision angle range of core and cavity mould pieces. By comparing ACCDS with a recent system proposed by a researcher, improvements such as better core and cavity design and the reduction of system computational time were observed. This shows that ACCDS were able to contribute in the betterment of the core and cavity design system in automatic manner.

CHAPTER ONE

INTRODUCTION

1.1 Background Study

Plastic parts are found everywhere in our daily life, for home, transportation, medical needs, electrical appliances and many more. The injection moulding industry in Malaysia takes about 34% of the total production processes (Malaysian Plastic Manufacturers Association 2014). Quoted from the Plastic and Rubber Asia magazine, President of The Malaysian Plastics Manufacturers Association (MPMA) Lim Kok Boon said that the manufacturing cost of plastic productions is increasing by more than 10%. He added that the manufacturing cost is however able to be reduced by shortening the amount of processing and production time with the assistance and application of advanced manufacturing technology (Plastic and Rubber Asia 2014).

Developing an advanced manufacturing technology is not an easy task. Manufacturers in Malaysia are confronted with many challenges to integrate advanced manufacturing technology into the existing technology. One of the challenges is to be able to quickly meet the consumers' change of demands. Nowadays, consumers not only demand for functional and high quality products, but also presentable with appearance that meets their taste. This leads to the complexity of product models which are increasing as the demand for modern, futuristic and artistic designs increases. Most of the plastic products are manufactured using injection moulding process and moulds are used. The most common mould is the two plate moulds which consist of a core half and a cavity half plate. However the design

for core and cavity changes as the product design changes. When a product model has high design complexity, it uses a large amount of time to manually create the core and cavity models. Hence researchers are trying to develop an automated core and cavity design system in order for the core and cavity models are able to be generated faster and for a large variety of complex designed product models.

System automation includes fast information transfer between CAD – CAPP – CAM systems. Core and cavity design system falls under the CAPP system since it takes product design information from the CAD system and gives machining information to the CAM system. For most newly developed core and cavity design system, generative method is commonly used. Generative method is a method where the core and cavity models are generated from scratch. Unlike variant and hybrid methods where a large library of existing core and cavity model is used as a basis. In order to develop the core and cavity design system, many aspects in creating the core and cavity model must be put into consideration such as the parting elements, undercuts, number of side-cores and many more. These are the fundamental aspects for an automated core and cavity design system to work. There are various approaches used by previous researchers to cover these aspects and develop an improved automated core and cavity design system. Even so, there are always room for improvements as the product design complexity increases. Several years before, products are designed with regular shapes and the mixture of it, but in recent years, with high demand of artistic designs, sculptured or free-form shapes are becoming more common. This increases the challenge for automated core and cavity design system not only to generate the core and cavity models but also for tool orientation during machining.

In order for Malaysia's manufacturing industry to be at par with other leading countries, integration of advanced manufacturing technology is highly important. In fact, this technology must be flexible enough to be able to comply with the fast changes of local and international demands.

1.2 Problem Statement

In recent years, some researchers have proposed and developed automated core and cavity design systems. However there were limitations in the proposed automated core and cavity design system. One of the limitations is the lack in parting direction flexibility of the system. In order to generate core and cavity models, predetermined parting directions were used. This restriction is a downside for complex product designs with free-form surfaces. Pre-determined parting directions may not be able to efficiently be used for all types of free-form surfaces. The second limitation is the inability of the previous systems to automatically detect and generate parting direction for both inner and outer undercuts. The previous system either focuses on inner undercuts only or outer undercuts only. This is a disadvantage for complex product designs that have both inner and outer undercuts. The final limitation is there are yet an automated system that links the core and cavity design system to a machining system. Information transfer between the two systems such as tool position and angle are important to avoid collision between tool and work piece during machining.

1.3 Aim and objectives of Study

To overcome the limitations stated in the previous section, this research aimed to develop a system named the automated core and cavity design system (ACCDS) that is a component of a CAPP system linking CAD and CAM systems. This goal were accomplished by four important objectives listed as follow:

1. To generate visibility range of faces in the part body using visibility map (V-map) approach.
2. To determine the best parting direction from grouped faces using edge convexity and face connectivity approach.
3. To determine the internal and external side-core direction using parallel test approach.
4. To generate tool position range for faces in core and cavity using plane projection approach.

1.4 Scope of Study

This research focuses on developing ACCDS which specifies on core and cavity design. Core and cavity is one of the main injection mould components that directly affects the quality of the final product, which is known as the heart of the injection mould (Cracknell & Dyson 1993). It would be pointless if other mould components are designed extensively but the core and cavity design is scarce.

ACCDS focuses on two plate moulds only since it is the basic mould for core and cavity plates. Even so, it is not restricted from complex product designs since side-cores are generated as options for irremovable undercuts. The system is developed on the C++ and geometric modelling kernel platform. The approaches

used for this system is modified to fit this platform. In the proposed algorithm, representations of V-map were made to enhance the algorithm processing speed using B-rep shapes. This method retrieves information such as the vector of a certain parting direction where conversion from shape to value is done at the end of each sub-processes.

1.5 Research Approach

Quantitative and deductive approaches were used for this research. Studies and comparison of recent proposed systems, theories and algorithms were made in order to highlight the changes that could be done to improve the core and cavity design system. Hypothesis was made by mixing and matching existing approaches that were used by previous researchers to create new and improved algorithm for ACCDS. The ACCDS were tested and observations were made by comparing the ACCDS output with previous researchers' output. The comparisons confirm whether the proposed algorithm in ACCDS is of assistance in improving the core and cavity design system.

1.6 Organization of thesis

This thesis is arranged in five chapters which include introduction, literature review, methodology, result and discussion, and conclusion. Each chapter provides all the necessary information and findings related to the study and research.

In Chapter One which is introduction, the first section briefly introduces the background of this research. The problem statement is described in the section two

while the third section lists out the aim and objectives of the research. The next sections introduce the focus of the study and research approach while the last section explains the arrangement of the whole thesis.

In Chapter Two which is literature review, the chapter is divided into thirteen sections. The first to fifth section explains the current technology of integration between computer-aided techniques into mould design. The sixth to twelfth section describes the method and approaches of previous researchers. The final section summarizes the important components in mould design and the approach selected in this research.

In Chapter Three which is methodology, the first section illustrates the overall flow of the ACCDS and then briefly describes each of the sub-processes. The next sections explain in detail each sub-processes of the developed system, the approaches that were applied, and the equations that were used.

In Chapter Four which is result and discussion, the system were validated by taking two 3D CAD model as input to the system. The results and outputs generated were discussed in detail. Comparison was also made with output from previous researcher.

In Chapter Five which is conclusion, the findings of the study is summarised and a conclusion is made. Several recommendations and future works are proposed.

CHAPTER TWO

LITERATURE REVIEW

2.1 Manufacturing Technology

Manufacturing technology has been constantly growing since the 80's with the introduction of computer-based system in all stages of product development starting from marketing, industrial design, product engineering, tooling and production. In the earlier days of manufacturing, the development of a new product uses the "over-the-wall" concept where the process always begins at the marketing stage which new ideas for a product are generated. Then the information is passed to the next stage which is industrial design where the initial model is developed with concern of ergonomics and aesthetics of a product. The design is then passed to product engineering stage where the final requirements of a product are ensured by deciding the type of material and manufacturing processes. Then the design and information are passed to the next stage which is tooling where the tooling engineer decides the tool design and tool fabrication. If the design and information from every stage is approved by the production engineer and possible to manufacture, the designed product is ready for the last stage which is the production stage (Malloy 2011). This concept of passing forward information from one stage to another and passing backwards when a problem arises can take a great amount of time before a designed product can actually be manufactured. Therefore a better concept is replaced known as concurrent engineering. The advantage of this concept is the ability to work in parallel among the marketing, design and production team. In recent decade, digital manufacturing has revolutionized this concept, allowing for

more improvements and giving it a new approach which integrates computer technology. Digital manufacturing has been a promising technology that reduces the product development time and cost while at the same time fulfilling to market demands, increasing the quality of products and addressing the need of customization (Chryssolouris et al. 2008). The example of concurrent engineering meets digital manufacturing is the computer-aided process planning (CAPP) which was introduced in the early 80's and became a better solution for the previous concept. CAPP uses computer systems to aid in the manufacturing process planning which bridges the computer-aided design (CAD) and computer-aided manufacturing (CAM) (Tepic et al. 2011).

A report by US-based software company, Citrix, stated that a new wave of technology, the internet-of-things (IOT) or also known as Industry 4.0, will not only make the gap between production and corporate level decision makers closer by transferring data more streamlined and efficient, but also narrow the gap between marketing team and manufacturing team to ensure designed products are up-to-date based on market demand. The automation of manufacturing system has also improved and helped to optimize the manufacturing process.

2.2 CAPP

Process Planning is the systematic determination of operation sequence and work centres to manufacture a product and its components economically from the initial stage in the form of raw material to the final stage where the desired form is produced. The process planning that is assisted by a computer is called CAPP. Initially, the design team creates a 3D CAD model using CAD systems that are

equipped with design knowledge. Then, the process planning team takes the 3D CAD model and creates a process plan using CAPP systems with process planning knowledge. Finally, the manufacturing team takes the process plan and creates a numerical control (NC) code using the CAM system with manufacturing knowledge. These processes are linked with one another with the aid of computers which makes the passing of information faster and more efficient.

Among other benefits of CAPP are, the reduction of cost as the use of resources are efficient, productivity increased, and more accurate and consistent plans are produced (Todic et al. 2008). The previous manual process planning has many limitations such as inconsistent plans that are tied to the knowledge, experience and skill of the planner, and inefficient communication between design team and manufacturing team. These are the reasons why manufacturing firms and researchers started to try to automate the task and come up with different strategies (Elmaraghy 1993). Generally, there are two types of strategy, a lower level and higher level strategy. The lower level strategy only uses the computer to store and retrieve information or data for the process plan while the higher level strategy generates the process plan automatically without human interaction.

There are basically three approaches to a CAPP system. The first approach is the variant approach or also known as the retrieval approach. This approach uses the group technology (GT) code to select an existing process plan developed for each part family and then make small changes to suit the part design. The second approach is the generative approach (Cai et al. 2011). This approach analyses the part design information and creates a process plan from scratch without the intervention of human. The third approach is the hybrid approach or known as semi-generative approach (Wang et al. 2009). This approach is a combination of the two mentioned

approach where it uses the variant approach to retrieve an existing process plan and makes changes using the generative approach to suit the part design.

In plastic part production, especially when manufactured with injection moulding or other processes that uses a die or mould, the production processes are somewhat different. The process planning not only includes for the part but also for the die or mould.

The design of plastic part and mould should run simultaneously as both are closely related to each other. Any mistakes in either one of the design would result in failure of the final product. The part design not only should be mouldable but also removable from the mould. To ensure these two criteria, the part design must be integrated and analysed together with the mould design. This is similar to the process planning for the part and mould. The process planning for the part is related to the mould while the process planning of the mould is related to other machining processes such as milling, lathing, drilling, etc. A mould can be considered as a tool for the plastic part production, but at the same time is also a part itself that needs production hence the process planning of its own.

The use of computer in part design, mould design and process planning have greatly assisted the transfer of information and concurrent engineering in plastic part production and decreased the production time especially in the design phase where the change of information between part design and mould design is very crucial (Bernhardt 1983).

2.3 Injection Moulding

Plastic parts with simple or complex geometries, in small or large volumes, and in little or many quantities can be produced using high speed and automated injection moulding process. The injection moulding process is divided into six major steps which are clamping, injection, dwelling, cooling, mould opening, and product removing.

The injection moulding machine (Figure 2.1) is mostly divided into three units which are the clamping, moulding and injecting unit. The clamping unit is functioned to open, close and clamp the mould, and to eject the product from the mould. The moulding unit is functioned to shape and cool the injected molten plastic. The injecting unit is functioned to melt plastic resins using heat and inject the molten plastic into the mould.

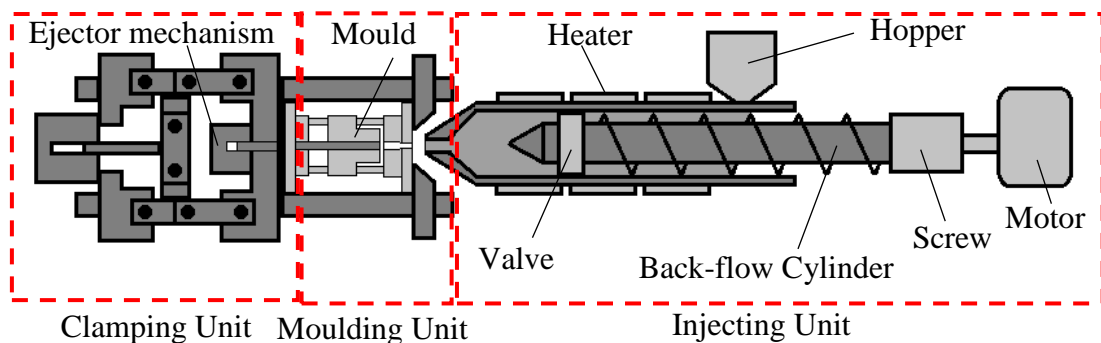

Figure 2.1. Injection moulding machine (Dominic et.al. 2000)

2.4 Moulding Unit

The main component of an injection moulding machine is the mould. A basic and low cost type of an injection mould is the two-plate mould which is built up of a stationary and movable plate, sprue, gate, core and cavity, cooling channels,

air vents, guiding pins, and ejector pins. A more complex two-plate mould may have other components such as side-cores, inserts, etc. The two-plate mould is the cheapest to manufacture, easiest to maintain and have a longer mould life.

The most standard and common mould base is the A-style (Figure 2.2(a)). It is the most commonly used mould base as it has the flexibility to fit into wide variety of moulding applications. The A-style models consist of top clamp plate, A-plate, B-plate, support plate, ejector retainer, ejector bar, and ejector housing. The versatility of this mould base is that it can accept any kind of core and cavity inserts by machining pockets into the A-plate and B-plate. Another economical option to the A-style is the B-style mould base. The B-style (Figure 2.2(b)) mould base combines the top clamp plate and the A-plate into one plate called the A-clamping plate, and combines the B-plate and support plate into one larger sized B-plate. This style however must machine the core and cavity into the plates or machine a blind pocket for a core and cavity insert.

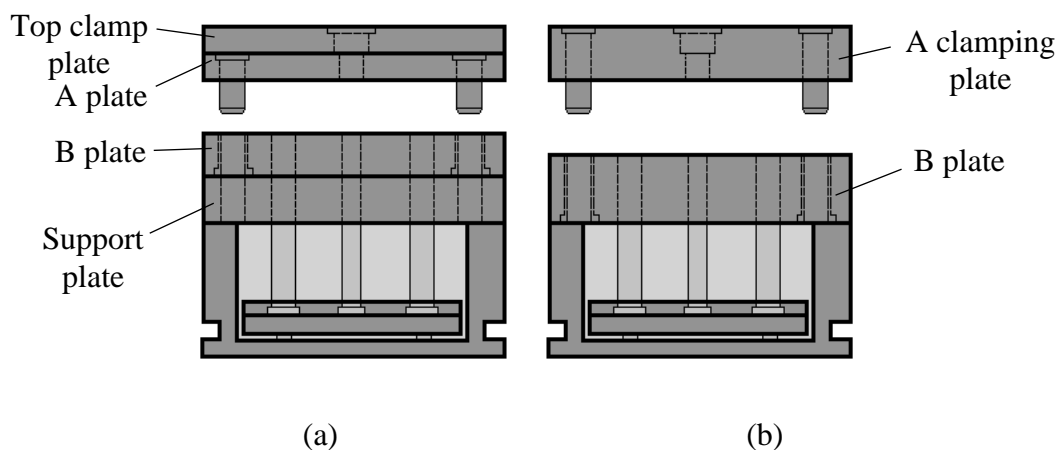

Figure 2.2. Injection mould model (a) A-style (b) B-style (Dominic et.al. 2000)

(a) Core and Cavity

A two-plate mould pulls away from each other during ejection along the parting direction and the core and cavity is separated at the parting lines and parting surfaces. Core and cavity is one of the important components in injection mould because the quality of the moulded product is mostly reliant on it. There are two methods to include the core and cavity into the mould. The first method is to machine the core and cavity directly into the mould plates, and second is to create separate core and cavity inserts that will be assembled into a pocket of the mould plates.

In designing the core and cavity of a mould, the earliest decision that needs to be made is to determine the parting elements such as parting direction, parting line and parting surfaces. This is to ensure that the designed part is mouldable and removable from the mould. This is possible if the core and cavity has no undercut, and all external and internal parts of the mould do not collide with each other during separation along the parting direction (Khardekar et al. 2006).

(b) Side-cores

Certain complex designed parts are not mouldable with a basic two-plate mould. The design team would usually try their best to remove any undercuts, however at times such undercuts are unavoidable. Undercuts are surfaces of the designed part that are unable or difficult to be removed along the main parting direction during ejection unless with special mechanism. Hence, side-cores are incorporated to accommodate the undercuts while keeping the mould cost at minimal. A designed part can be categorized into several categories; without

undercuts, with external undercuts, with internal undercuts or with external and internal undercuts (Fuh et al. 2004).

Small and flexible undercuts are usually stripped from the mould. Undercuts that cannot be stripped uses other mechanism such as a moving core. The core moves by sliding sideways either horizontally or at an angle (Rees 2002). This mechanism is used with other mechanisms such as leader pins or lifter to enable a complete product ejection. The moving core when closing needs a mechanism to guide the core to its original position. This is achieved either by leader pins or extended mould base also known as interlocking surfaces.

The inclined leader pin moves the sliding core sideways away from the undercut during the mould opening (Figure 2.3) releasing the undercut and moulding ready to be removed. When the mould closes, the leader pin will guide the sliding core back to its original position. The leader pin is suitable for external undercuts. For internal undercuts, a lifter is used. The lifter is either a moving core itself or an assistance to a moving core which acts like the leader pins. If the lifter is a moving core, it releases the undercut as it eject the part, while if the lifter is an assistance to a moving core, it allows a delayed onset of the lateral movement. The moving core lifter is used only if there is space for the lifter to move sideways away from the undercut (Figure 2.4).

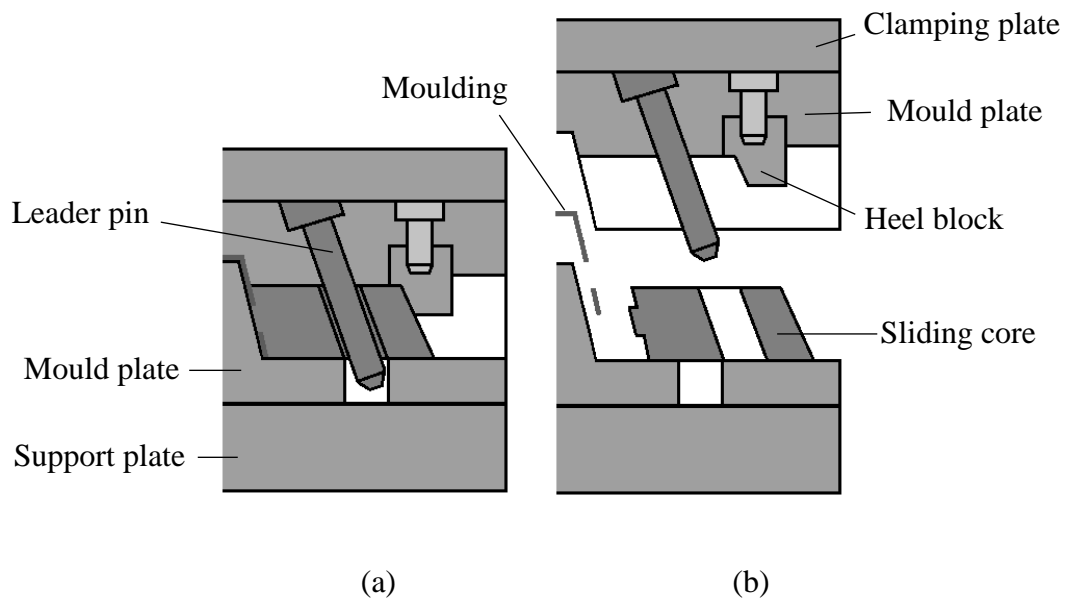

Figure 2.3. Leader pin (a) closed mould (b) opened mould (Menges et al. 2001)

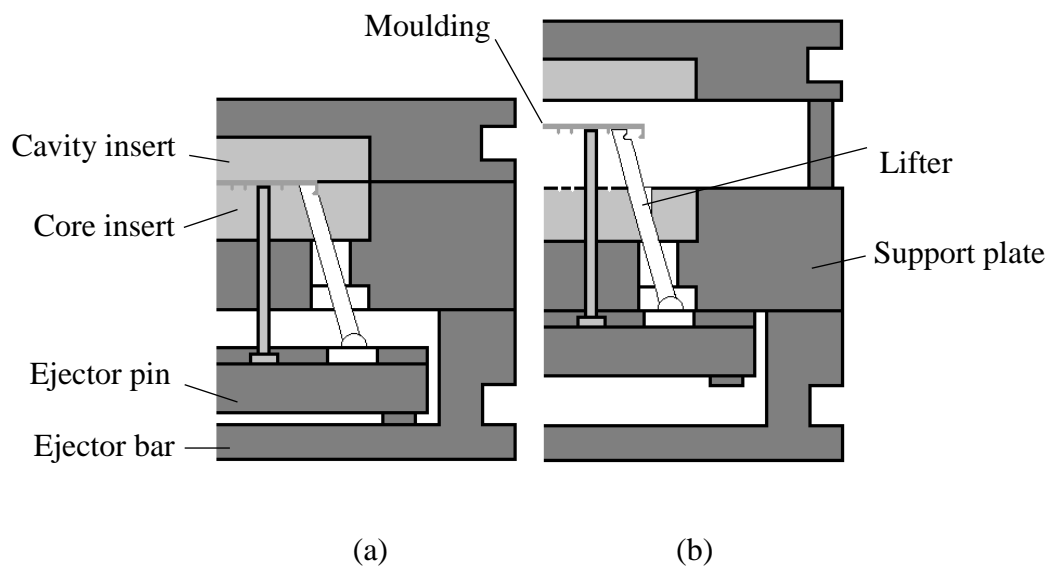

Figure 2.4. Lifter (a) closed mould (b) opened mould (Menges et al. 2001)

Any other design features must not interfere with the lifter movement. If there are limited spaces, the second type of lifter is preferable as it can be used without having to provide too much space for the lifter movement.

(e) Parting Elements

There are three parting elements (Figure 2.5) that parts the core and cavity moulds which are parting direction, parting line and parting surface.

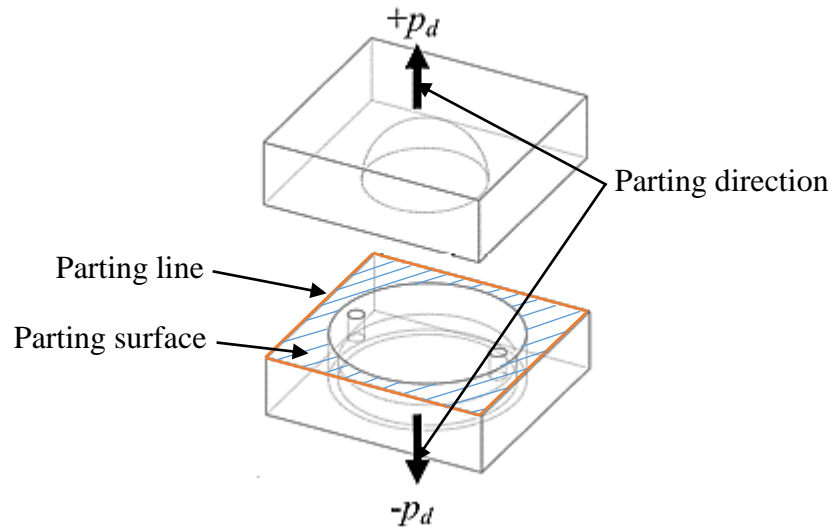

Figure 2.5. Parting elements (Md Yusof & Abu Mansor 2015)

Parting direction is the main direction along which the core and cavity moves during separation. The cavity moves along positive parting direction ($+p_d$) while the core moves along negative parting direction ($-p_d$) or vice versa. Parting line is the outer most line of parting surface, and parting surface is the surface where the core and cavity splits.

2.5 Mould Machining

The most common and advanced machining process that is used to manufacture and produce core and cavity is the CNC multi-axis machining. CNC multi-axis machining have more than three motions which combines the translational and rotational motion. These motions are either applied on the tool holder, machine

table or both. The combination of translational and rotational motions makes machining of any type of surfaces possible especially for free-form surfaces. By changing the tool type, the CNC machine can be applied in various processes such as turning, milling and drilling (Youichi et al. 2012). There are many various types of CNC machines, one of them is the Parallel Machine Tool (PMT) where it can contain more than one spindle and hold many work pieces at the same time. The CAPP for PMTs has led for possible research including feature extraction, user interfaces, collision avoidance and operation sequencing (Norman & Bean 1997). In multi-axis CNC machining, several processing information is needed such as the tool path planning, tool orientation, tool shape and size, spindle speeds and travelling velocity (Lasemi et al. 2010). This information are usually decided by the engineers in charge with the aid of CAM systems.

The current available CAM systems may simulate generated tool path and orientation and analyse for collision, however there are limitations in functionality for multi-axis tools (Lauwers et al. 2003). Traditionally, the tool orientation is fixed at an angle from 3° to 10° from the surface normal. This increases the chances of collision between multi-axis tools and work piece with free-form surfaces. This however can be avoided by changing the tool orientation during machining. There are three types of cutter interference, which are local gouging, rear gouging and global collision (Jun et al. 2003). Researchers have been studying different methods to optimize the tool orientation and one of the methods is using configuration space (C-space). C-space is a representation of tool orientation in space where the obstacles are mapped. The concept is somewhat similar to visibility map (V-map). This is similar in the work of Kumazawa et al. (2015) where discrete bi-directional field or

tensor field is used to map the preferred machining directions for a three-axis free-form surface.

2.6 CADIMDS

In the past few years, research activities have been carried out to integrate computer-aided techniques into mould design in order to improve the information flow between part and mould design. The range of research may vary from specific areas to a whole system of mould design. Mok et al. (2008) classified the research area into three; the functional and initial mould design, the algorithms to automate mould generation and system development of mould design.

Since 1990s, CADIMDS have become a focus for both the researchers and industry. Fu et al. (2001) proposed a system in CADIMDS where the architecture of the system is shown in Figure 2.6. A solid, surface or wireframe model is input into the system to be redesigned to suit for manufacturing and the mould of the part is created in mould design system. The mould design system is divided into seven sub-systems which are parting, feeding, cooling, ejection, mould base, local tool and standard components. All the sub-systems may have their own database and knowledge base that is needed to design the respective components. Commercial CAD software and CAM system may also be a tool to assist the design of components in the sub-systems. The process modelling and structural analysis generated from the mould design system stage is used to create mould prototypes and models. After the mould prototypes and models are analysed, the part is then redesigned if needed. These steps are repeated until the best part and mould model is created.

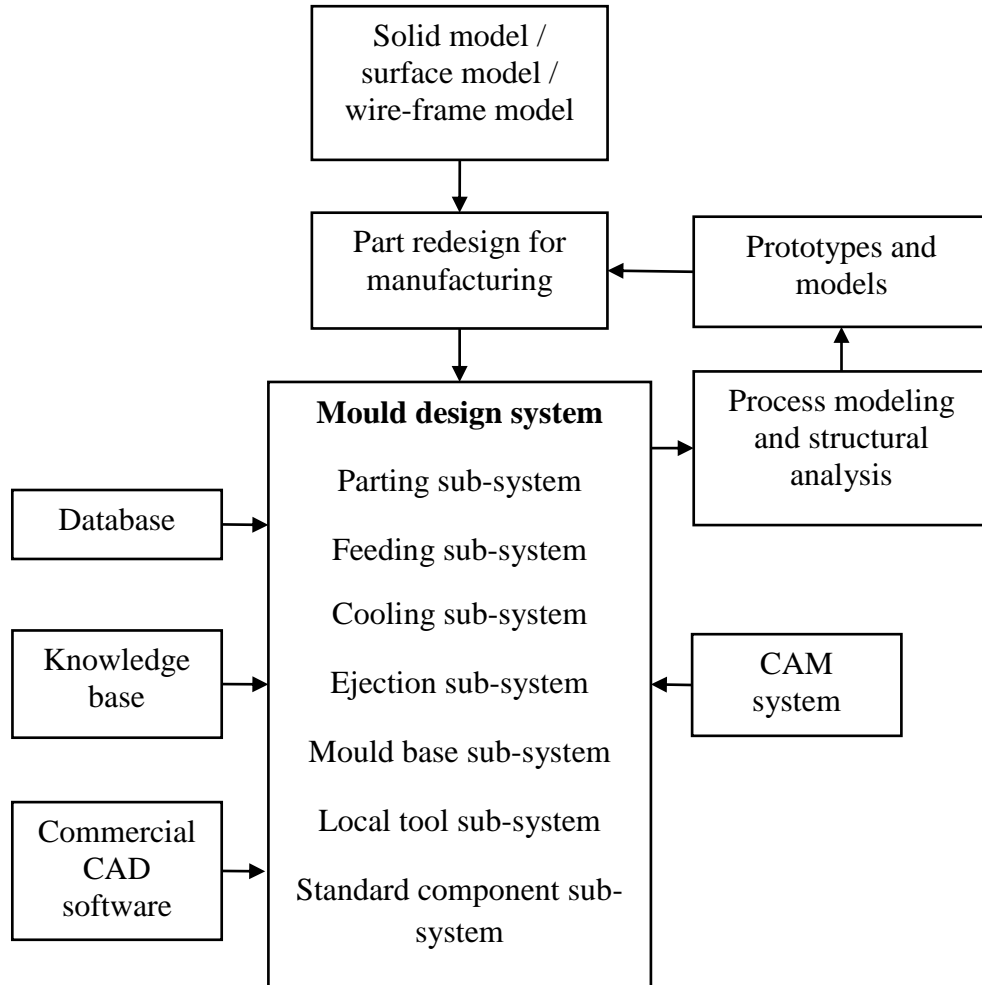

Figure 2.6. Architecture of CADIMDS (Fu et al. 2001)

Core and cavity generation is one of the main activities in parting sub-system in CADIMDS including the feature recognition such as undercuts, parting direction determination, parting line and parting surface generation (Fu et al. 2001). Various method and algorithm were proposed to automate the parting sub-system. A simple method proposed by Md Yusof and Abu Mansor (2015) took the user defined parting direction and used slicing approach to generate the parting surface and Boolean-based approach to generate the core and cavity. Slicing planes with constant height distance were used to slice the subtracted mould to create two halves. The two halves were then analysed for undercut and floating lump. The two halves that have zero undercut were selected as the best core and cavity and the floating lump were

united to the core half or cavity half to complete the core and cavity. A more complex method proposed by Singh and Madan (2013) assumed the parting direction to be along +z and -z axis and identified undercuts and protrusions using up and down facets, identified core and cavity surfaces using non-convex regions and determined the optimal parting line using parting line region and weighted decision criteria. A number of STL parts were tested and the computational time varied from a few seconds to a few minutes subject to the intricacy of the part. Another complex method proposed by Lin and Quang (2014) took a collection of parting directions and grouped visible-mouldable surface fragments into appropriate mould-piece regions by applying ordered criteria. Two CAD parts were used to implement the proposed method. Both input were computed less than 5 minutes.

Based on the methods proposed by the above researchers, it is crucial for the parting direction to be defined first.

2.7 Parting direction

Parting direction is a pair of opposite directions along which the halves of mould pieces withdraws away from each other. Various methods and approaches were used by previous researchers to determine the best parting direction for a part and its mould.

In the work of Lin and Quang (2014), possible parting directions were collected from three types of direction; relative coordinate axes, axes of features of revolution and normal directions of planar surfaces. These types of direction are formed based on the part's feature and geometrical properties. The part's surfaces are grouped based on a set of criteria and surface visibility along each collected direction

using ray test. Additional parting directions are then added into the collection if any undercut is detected afterwards. Gaussian map and visibility map are used to detect the undercut and determine the parting direction of the undercuts. Similarly, Priyadarshi and Gupta (2004) also listed three types of candidate parting directions; directions associated with coordinate system, planar face normal and cylindrical/conical face axis. Every faces on a part is analysed at each candidate direction and mould-piece regions are formed by connecting the faces with at least one similar candidate parting direction.

Restricted definition of a parting direction such as the methods reviewed above however reduces the flexibility of the system to compute CAD parts with higher complexity. Method to generate parting direction for free-form surfaces where also not included. Hence, some researcher focuses on methods to determine the optimal parting direction using feature recognition.

2.8 AFR

AFR is an approach widely used in mould design to construct feature-based representation scheme and recognize part features using algorithms, part geometry and part topology. Stefano et al. (2004) defined the main purpose of AFR is to make use the information extracted by the geometrical representation of solid models for future processes. Many researchers in the mould design scope focus mainly on the recognition of undercut, however there are other researchers (Bok and Abu Mansor 2013) that categorizes other features such as protrusion, depression and through holes as these features could also lead to undercut.

2.8.1 Undercut Feature Recognition

There are two types of undercut; internal and external (Hui 1997). Internal undercut is a surface region (a face or a group of faces) which prevents the withdrawal of a moulding along a parting direction from the core while external undercut prevents the withdrawal from the cavity (Nee et al. 1997). The identified feature that cannot be moulded is based on the relationship of undercut direction, u_d and parting direction, p_d where $u_d \cdot p_d \neq 0$ (Fu et al. 2001). Nee et. al. (1998) added that the undercut direction and undercut volume are the two main parameters in optimizing the parting direction. The parting direction is optimized by selecting the undercut direction of an undercut group with maximum volume. There are several methods to recognize undercut features such as geometrical, graph based, volume based and others.

2.8.2 Geometrical Method

In a part's body, faces are classified into three features; (1) surfaces that can be moulded by the core, (2) surfaces that can be moulded by the cavity and (3) surfaces that can be moulded by the core and cavity or by the side-core (undercut). The classification criteria is based on the relationship of the parting direction, p_d with the face normal, N , where the relationship of the two in the first classification is $p_d \cdot N > 0$, the second classification is $p_d \cdot N = 0$ and the third classification is $p_d \cdot N < 0$. This is similar in the work of Bok and Abu Mansor (2013) where the faces in surface recognition are classified into three category; top, contour and bottom. The criteria is decided based on the relationship of magnitude of vector xyz component of the face and the parting direction at z-axis. A face is classified as top face when the xyz

vector magnitude is in range $-1 \leq |X| \leq 1$; $-1 \leq |Y| \leq 1$; $|Z| > 0$, contour face is in range $-1 \leq |X| \leq 1$; $-1 \leq |Y| \leq 1$; $|Z| = 0$, and bottom face is in range $-1 \leq |X| \leq 1$; $-1 \leq |Y| \leq 1$; $|Z| < 0$.

It is also essential to distinguish the surface type whether free-form or regular to compute the visibility of each surface. Chen et al. (1993) stated that a surface can either be completely visible, partially visible or not visible at the specified directions. A surface of a face is completely visible at a direction if every point on the surface is visible while it is partially visible if at least one point is not visible (Chen et al. 1995). For a free-form face, Chakraborty and Venkata (2009) used tessellation to create surface points on the surface to estimate the visibility direction of a free-form face along the specified directions.

Fu et. al. (2002) classified three types of surfaces which are planar, curved and free-formed surfaces. A planar surface has a normal vector used to determine the surface visibility which is complete, partial or invisible. A curved surface however is dependent on several cases; closed cylindrical, closed conical or closed spherical surfaces. A free-formed surface has different normal vectors at different locations and therefore the visibility of the whole surface is determined by the visibility of the nodes in the surface.

In summary, the geometrical method uses the relationship of surface geometry (face normal, surface type etc.) and the parting direction to classify the surfaces and detect undercuts.

2.8.3 Graph Based Method

Another method of undercut recognition is the graph based recognition. This method detects an undercut by matching the feature graph of recognized undercut with the appropriate sub-graph in a graph representation of the part (Gao & Shah 1998). Using polyhedron face adjacency graph, Kumar et al. (2006) developed a method to recognize completely visible and partially visible undercuts. If the dot product of normal of nodes on the undercut surfaces and normal of nodes on the surfaces adjacent to the undercut surface is all positive, the undercut is considered completely visible while if even one of the dot product is negative, the undercut is considered partially visible. Similarly, Shao and Shen (2010) proposed a method extending the Face Adjacency Attribute Graph (FAAG) to Extended Face Adjacency Attribute Graph (EFAAG). The attributes of nodes and edges are defined and sub-graphs of the undercut features are recognized by group matching. The face attribute is defined either exist an internal loop in FAAG or non-existent while the edge attribute is defined as concave or convex edge and internal or external loop edge.

In summary, the graph based method uses nodes on a surface and between surfaces to create graph representation of the part to detect undercuts.

2.8.4 Volume Based Method

Yin et al. (2001) proposed a volume based feature recognition method to recognize isolated and interacting undercut features. The potential undercut features were obtained by volume decomposition where partitioned regularized difference between part and its convex hull were decomposed into basic convex cell. The undercut directions were determined using freedom cone. Freedom cone is a set of

all feasible local motion directions for an object that is constrained by a certain grasp. An object without constrain will form a 6D vector space local motion.

This method subtracts a part from its convex hull and uses the remaining solid to detect undercuts.

2.8.5 Other Methods

In the work of Ran and Fu (2010), deep inner undercuts are recognized using projection. If the projection of the inner undercut outline intersects the projection of the same component at both parting direction and undercut direction, the part is considered of having an inaccessible deep inner undercut.

The undercut feature can also be recognized using parallel rays. Parallel rays are rays along a specified direction which is omitted from a point in infinity space onto a face to analyse the visibility of the face at that direction (Liu et al. 2009).

2.8.6 Visibility Map

The most prominent approach to determine the parting direction in core and cavity design is the visibility map (V-map) approach. V-map is a unit sphere with the centre point at the origin and maps out unit vectors of direction where the tail of the vector is at the origin and the head at the surface of the sphere (Khardekar et al. 2006). The difference between V-map and Gaussian Sphere is the type of direction it maps out. Gaussian sphere maps out the normal vectors of faces while V-map maps out the visibility vectors of faces (Gan et al. 1994). Visibility vectors are directions