

**EFFECT OF FOOD-DRUG INTERACTION ON ORAL DRUG
BIOAVAILABILITY**

by

LIM SHEAU CHIN

**Thesis submitted in fulfilment of the requirements
for the Degree of Master of Science**

June 2006

ACKNOWLEDGEMENTS

I wish to express my deepest gratitude to my supervisor, Professor Dr. Yuen Kah Hay for his advice and guidance throughout my postgraduate study. His patience, encouragement and assistance are most valuable and deeply appreciated. My heartiest appreciation also goes to my co-supervisor Dr. Nurzalina Abdul Karim Khan for her fruitful suggestions as well as her unfailing supports.

I would like to thank Dr. Ng Bee Hong for her constructive comments and advices in preparing the manuscripts, apart from being my mentor and friend. My sincere thanks also go to Dr. Sharon Ling Sheue Nee, Ms. Lim Ai Beoy, Mr. Loon Yit Hong and Ms. Grace Lee for their assistance in all the animal studies. Also, not forgetting to thank Ms. Choy Wai Peng, Dr. Irene Yap Siew Ping, Dr. Wong Jia Woei and Mr. Wan Teow Seng who have never failed to offer their help and support in the course of my study.

I am also indebted to my labmates and friends Pay Kim, Shaun, Sin Yee, Siew Siew, Sandy, Enrico, Bee Yean, Phaik Chin, Mei Mei, Erena, Kamarul, Yin Wai, Hooi Ling, Ching Khee, Musab, Mahmoud, Jiyauddin, Gamal, Sabiha, Nagamani and Samer for helping out in one way or another and their friendship. My heartfelt appreciation is also extended to my friends, Huang Hui, Feong Kuan, Ying Ying, Sheo Kun and all those whom unable to be named here, for being there whenever need arises. From the bottom of my heart, our friendship will always be cherished and treasured.

Also, I would like to thank the Dean and all other staff of the School of Pharmaceutical Sciences, USM and Hovid Bhd, Ipoh especially Hovid R&D laboratory in USM, Penang for providing me support and assistance as well as a conducive environment to accomplish my research goal. Appreciation also goes to Ministry of Science, Technology and Innovation, Malaysia for sponsoring me NSF Scholarship for one and a

half years. Not forgetting also to thank Pepper Marketing Board, Kuching for their generous supply of the piperine extract.

Last but not least, I wish to express my utmost gratitude and heartiest appreciation to my parents and family members for their continuous support throughout my educational years and most of all, for believing in me. I am immensely grateful for being brought up in the environment of boundless love which has nurtured me to who I am today.

*To my beloved parents, Lim Cheng Peng and Then Choon Kee,
and family members*

CONTENTS

| | PAGE NUMBER |
|--|-------------|
| TITLE | i |
| DEDICATION | ii |
| ACKNOWLEDGEMENTS | iii |
| CONTENTS | v |
| LIST OF TABLES | xii |
| LIST OF FIGURES | xv |
| LIST OF EQUATIONS | xix |
| LIST OF SYMBOLS, ABBREVIATIONS OR NOMENCLATURE | xx |
| LIST OF APPENDICES | xxiv |
| ABSTRAK | xxviii |
| ABSTRACT | xxx |
| | |
| CHAPTER 1 INTRODUCTION | |
| 1.1 General Introduction | 1 |
| 1.2 Drug transport across cell membranes | 1 |
| 1.2.1 Paracellular pathway | 2 |
| 1.2.2 Transcellular pathway | 3 |
| 1.2.2.1 Passive diffusion | 3 |
| 1.2.2.2 Carrier-mediated transport | 5 |
| 1.2.2.2.1 Active transport | 6 |
| 1.2.2.2.2 Facilitated diffusion or transport | 6 |
| 1.2.2.3 Vesicular transport | 7 |
| 1.3 Oral drug absorption from the gastrointestinal tract | 8 |
| 1.3.1 The stomach | 8 |
| 1.3.2 Small intestine | 10 |

| | |
|---|----|
| 1.3.3 Large intestine | 12 |
| 1.4 Role of transporters and metabolising enzymes in small intestine on oral drug bioavailability | 13 |
| 1.4.1 P-glycoprotein (P-gp) | 17 |
| 1.4.2 Intestinal phase I metabolising enzyme, CYP3A | 20 |
| 1.4.3 Interactions between gastrointestinal P-gp and CYP3A | 22 |
| 1.5 Food-/herb-drug interactions | 25 |
| 1.6 Model drugs as substrates of P-gp and CYP3A | 28 |
| 1.6.1 Diltiazem | 28 |
| 1.6.2 Rifampicin | 30 |
| 1.7 Scope of study | 32 |

CHAPTER 2 DEVELOPMENT OF A SIMPLE HIGH-PERFORMANCE LIQUID CHROMATOGRAPHIC METHOD FOR DETERMINATION OF RIFAMPICIN IN HUMAN AND RAT PLASMA

| | |
|---|----|
| 2.1 Introduction | 34 |
| 2.2 Materials | 35 |
| 2.3 Instrumentation | 36 |
| 2.4 Sample preparation | 36 |
| 2.5 Standard solutions and calibration curves | 36 |
| 2.6 Method evaluation | 37 |
| 2.7 Results | 37 |
| 2.8 Discussion | 42 |
| 2.9 Conclusion | 44 |

CHAPTER 3 DEVELOPMENT OF A SIMPLE HIGH-PERFORMANCE LIQUID CHROMATOGRAPHIC METHOD FOR DETERMINATION OF DILTIAZEM IN HUMAN AND RAT PLASMA

| | |
|---|----|
| 3.1 Introduction | 45 |
| 3.2 Materials | 46 |
| 3.3 Instrumentation | 46 |
| 3.4 Sample preparation | 47 |
| 3.5 Standard solutions and calibration curves | 47 |
| 3.6 Method evaluation | 47 |
| 3.7 Results | 48 |
| 3.8 Discussion | 51 |
| 3.9 Conclusion | 54 |

CHAPTER 4 INFLUENCE OF CAPSAICIN ON THE ORAL BIOAVAILABILITY OF DILTIAZEM AND RIFAMPICIN

| | |
|---|----|
| 4.1 Introduction | 55 |
| 4.2 Resources | 57 |
| 4.2.1 Materials | 57 |
| 4.2.2 Animals | 57 |
| 4.3 Methods | 57 |
| 4.3.1 Effects of single and multiple dose capsaicin co-administration on the oral bioavailability of diltiazem | 57 |
| 4.3.1 (a) Preparation of test formulations | 57 |
| 4.3.1 (b) Study protocol | 58 |
| 4.3.1 (c) Analysis of plasma diltiazem concentration | 61 |
| 4.3.2 Effects of single and multiple dose capsaicin co-administration on the oral bioavailability of rifampicin | 61 |

| | |
|---|----|
| 4.3.2 (a) Preparation of test formulations | 61 |
| 4.3.2 (b) Study protocol | 62 |
| 4.3.2 (c) Analysis of plasma rifampicin concentration | 63 |
| 4.3.3 Data and pharmacokinetic analysis | 63 |
| 4.3.4 Statistical analysis | 64 |
| 4.4 Results | 64 |
| 4.4.1 Effects of single and multiple dose capsaicin co-administration on the oral bioavailability of diltiazem | 64 |
| 4.4.2 Effects of single and multiple dose capsaicin co-administration on the oral bioavailability of rifampicin | 69 |
| 4.5 Discussion | 75 |
| 4.5.1 Study using diltiazem as the model drug | 75 |
| 4.5.2 Study using rifampicin as the model drug | 77 |
| 4.6 Conclusion | 78 |

CHAPTER 5 INFLUENCE OF CAFFEINE ON THE ORAL BIOAVAILABILITY OF DILTIAZEM AND RIFAMPICIN

| | |
|---|----|
| 5.1 Introduction | 79 |
| 5.2 Resources | 81 |
| 5.2.1 Materials | 81 |
| 5.2.2 Animals | 81 |
| 5.3 Methods | 81 |
| 5.3.1 Effects of single and multiple dose caffeine co-administration on the oral bioavailability of diltiazem | 81 |
| 5.3.1 (a) Preparation of test formulations | 81 |
| 5.3.1 (b) Study protocol | 82 |
| 5.3.1 (c) Analysis of plasma diltiazem concentration | 82 |

| | |
|--|-----|
| 5.3.2 Effects of single and multiple dose caffeine co-administration on the oral bioavailability of rifampicin | 85 |
| 5.3.2 (a) Preparation of test formulations | 85 |
| 5.3.2 (b) Study protocol | 85 |
| 5.3.2 (c) Analysis of plasma rifampicin concentration | 86 |
| 5.3.3 Oral bioavailability of caffeine after a single repeated administration | 86 |
| 5.3.3 (a) Preparation of test formulation | 86 |
| 5.3.3 (b) Study protocol | 86 |
| 5.3.3 (c) Analysis of plasma caffeine concentration | 87 |
| 5.3.4 Oral bioavailability of caffeine after a multiple dose administration | 88 |
| 5.3.4 (a) Preparation of test formulation | 88 |
| 5.3.4 (b) Study protocol | 88 |
| 5.3.5 Data and pharmacokinetic analysis | 89 |
| 5.3.6 Statistical analysis | 89 |
| 5.4 Results | 90 |
| 5.4.1 Effects of single and multiple dose caffeine co-administration on the oral bioavailability of diltiazem | 90 |
| 5.4.2 Effects of single and multiple dose caffeine co-administration on the oral bioavailability of rifampicin | 95 |
| 5.4.3 Analysis of caffeine in plasma | 101 |
| 5.4.4 Oral bioavailability of caffeine after a single repeated administration | 105 |
| 5.4.5 Oral bioavailability of caffeine after a multiple dose administration | 105 |
| 5.5 Discussion | 110 |
| 5.6 Conclusion | 112 |

CHAPTER 6 INFLUENCE OF PIPERINE ON THE ORAL BIOAVAILABILITY

OF DILTIAZEM AND RIFAMPICIN

| | |
|---|-----|
| 6.1 Introduction | 113 |
| 6.2 Resources | 117 |
| 6.2.1 Materials | 117 |
| 6.2.2 Animals | 117 |
| 6.3 Methods | 117 |
| 6.3.1 Effects of single and multiple dose piperine co-administration on the oral bioavailability of diltiazem | 117 |
| 6.3.1 (a) Preparation of test formulations | 117 |
| 6.3.1 (b) Study protocol | 118 |
| 6.3.1 (c) Analysis of plasma diltiazem concentration | 118 |
| 6.3.2 Effects of single and multiple dose piperine co-administration on the oral bioavailability of rifampicin | 121 |
| 6.3.2 (a) Preparation of test formulations | 121 |
| 6.3.2 (b) Study protocol | 121 |
| 6.3.2 (c) Analysis of plasma rifampicin concentration | 122 |
| 6.3.3 Data and pharmacokinetic analysis | 122 |
| 6.3.4 Statistical analysis | 123 |
| 6.4 Results | 123 |
| 6.4.1 Effects of single and multiple dose piperine co-administration on the oral bioavailability of diltiazem | 123 |
| 6.4.2 Effects of single and multiple dose piperine co-administration on the oral bioavailability of rifampicin | 129 |
| 6.5 Discussion | 134 |
| 6.6 Conclusion | 136 |

| | |
|---|------------|
| CHAPTER 7 SUMMARY AND GENERAL CONCLUSION | 137 |
| CHAPTER 8 SUGGESTIONS FOR FURTHER WORK | 140 |
| REFERENCES | 142 |
| APPENDICES | 161 |
| PUBLICATIONS | 182 |
| CERTIFICATE OF ACKNOWLEDGEMENT | 183 |

LIST OF TABLES

| | | Page |
|-----------|---|------|
| Table 2.1 | Regression parameters and statistics for calibration curves (n=6) of the plasma rifampicin assay method | 40 |
| Table 2.2 | Absolute recovery, within- and between-day precision and accuracy (n=6) of the plasma rifampicin assay method | 41 |
| Table 3.1 | Regression parameters and statistics for calibration curves (n=6) of the plasma diltiazem assay method | 50 |
| Table 3.2 | Extraction recovery, within- and between-day precision and accuracy (n=6) of the plasma diltiazem assay method | 52 |
| Table 4.1 | Sequence of administration of the model drugs (diltiazem oral solution; rifampicin oral suspension) with and without single dose of capsaicin co-administration | 59 |
| Table 4.2 | Sequence of administration of the model drugs (diltiazem oral solution; rifampicin oral suspension) with and without multiple dose of capsaicin pretreatment | 60 |
| Table 4.3 | Individual numerical values of AUC_{0-4h} , C_{max} , T_{max} and 90% confidence intervals for diltiazem with and without single dose capsaicin co-administration | 67 |
| Table 4.4 | Individual numerical values of AUC_{0-4h} , C_{max} , T_{max} and 90% confidence intervals for diltiazem with and without multiple dose capsaicin co-administration | 68 |
| Table 4.5 | Individual numerical values of AUC_{0-16h} , C_{max} , T_{max} and 90% confidence intervals for rifampicin with and without single dose capsaicin co-administration | 73 |

| | | |
|-----------|---|-----|
| Table 4.6 | Individual numerical values of AUC_{0-16h} , C_{max} , T_{max} and 90% confidence intervals for rifampicin with and without multiple dose capsaicin co-administration | 74 |
| Table 5.1 | Sequence of administration of the model drugs (diltiazem oral solution; rifampicin oral suspension) with and without single dose caffeine co-administration | 83 |
| Table 5.2 | Sequence of administration of the model drugs (diltiazem oral solution; rifampicin oral suspension) with and without multiple dose caffeine pretreatment | 84 |
| Table 5.3 | Individual numerical values of AUC_{0-4h} , C_{max} , T_{max} and 90% confidence intervals for diltiazem with and without single dose caffeine co-administration | 93 |
| Table 5.4 | Individual numerical values of AUC_{0-4h} , C_{max} , T_{max} and 90% confidence intervals for diltiazem with and without multiple dose caffeine co-administration | 94 |
| Table 5.5 | Individual numerical values of AUC_{0-16h} , C_{max} , T_{max} and 90% confidence intervals for rifampicin with and without single dose caffeine co-administration | 99 |
| Table 5.6 | Individual numerical values of AUC_{0-16h} , C_{max} , T_{max} and 90% confidence intervals for rifampicin with and without multiple dose caffeine co-administration | 100 |
| Table 5.7 | Regression parameters and statistics for calibration curves (n=6) of the plasma caffeine assay method | 103 |
| Table 5.8 | Extraction recovery, within- and between-day precision and accuracy (n=6) of the plasma caffeine assay method | 104 |
| Table 5.9 | Individual numerical values of AUC_{0-8h} , C_{max} and T_{max} for caffeine single repeated administration study | 107 |

| | | |
|------------|--|-----|
| Table 5.10 | Individual numerical values of AUC_{0-8h} , C_{max} and T_{max} for caffeine multiple dose administration study | 109 |
| Table 6.1 | Sequence of administration of the model drugs (diltiazem oral solution; rifampicin oral suspension) with and without single dose piperine co-administration | 119 |
| Table 6.2 | Sequence of administration of the model drugs (diltiazem oral solution; rifampicin oral suspension) with and without multiple dose piperine pretreatment | 120 |
| Table 6.3 | Individual numerical values of AUC_{0-4h} , C_{max} , T_{max} and 90% confidence intervals for diltiazem with and without single dose piperine co-administration | 127 |
| Table 6.4 | Individual numerical values of AUC_{0-4h} , C_{max} , T_{max} and 90% confidence intervals for diltiazem with and without multiple dose piperine co-administration | 128 |
| Table 6.5 | Individual numerical values of AUC_{0-16h} , C_{max} , T_{max} and 90% confidence intervals for rifampicin with and without single dose piperine co-administration | 132 |
| Table 6.6 | Individual numerical values of AUC_{0-16h} , C_{max} , T_{max} and 90% confidence intervals for rifampicin with and without multiple dose piperine co-administration | 133 |

LIST OF FIGURES

| | Page | |
|------------|--|----|
| Figure 1.1 | Mechanisms in membrane permeation | 2 |
| Figure 1.2 | Diagrammatic representation of carrier-mediated transport of a drug across a cell membrane (Ashford, 2002b) | 5 |
| Figure 1.3 | Localisation of selected transporters expressed in intestinal epithelial cells. (BCRP=breast cancer-resistance protein; MRP1-5=multidrug resistance protein family; P-gp=P-glycoprotein; PEPT1=oligopeptide transporter 1; CYP3A=metabolising enzymes belonging to Cytochrome P450 superfamily) | 14 |
| Figure 1.4 | Chemical structure of diltiazem HCl | 29 |
| Figure 1.5 | Chemical structure of rifampicin | 31 |
| Figure 2.1 | Chromatograms for the analysis of rifampicin in (a) human blank plasma, (b) rat blank plasma, (c) human blank spiked with 500.0 ng/ml rifampicin and (d) rat plasma containing 705.3 ng/ml rifampicin 2 hours after oral administration of 10.0 mg/kg rifampicin (y-axis, attenuation 6; x-axis, chart speed 2.5 mm/min). Peak 1=rifampicin | 38 |
| Figure 3.1 | Chromatograms for the analysis of diltiazem in (a) human blank plasma, (b) rat blank plasma, (c) human blank spiked with 80.0 ng/ml diltiazem and 4.0 µg/ml verapamil and (d) rat plasma containing 68.7 ng/ml diltiazem 1.5 hours after oral administration of 12.0 mg/kg diltiazem (y-axis, attenuation 6; x-axis, chart speed 2.5 mm/min). Peak 1 = diltiazem, peak 2 = verapamil | 49 |
| Figure 4.1 | Chemical structure of capsaicin | 55 |

| | | |
|------------|--|----|
| Figure 4.2 | Mean plasma concentration versus time profiles of diltiazem (mean±S.E.M., n=8) after oral administration of 12 mg of diltiazem per kg of rat with single dose co-administration of 4 mg/kg capsaicin | 65 |
| Figure 4.3 | Mean plasma concentration versus time profiles of diltiazem (mean±S.E.M., n=8) after oral administration of 12 mg of diltiazem per kg of rat with multiple dose co-administration of 4 mg/kg capsaicin | 66 |
| Figure 4.4 | Mean plasma concentration versus time profiles of rifampicin (mean±S.E.M., n=8) after oral administration of 10 mg of rifampicin per kg of rat with single dose co-administration of 4 mg/kg capsaicin | 70 |
| Figure 4.5 | Mean plasma concentration versus time profiles of rifampicin (mean±S.E.M., n=8) after oral administration of 10 mg of rifampicin per kg of rat with multiple dose co-administration of 4 mg/kg capsaicin | 71 |
| Figure 5.1 | Molecular structure of caffeine | 79 |
| Figure 5.2 | Mean plasma concentration versus time profiles of diltiazem (mean±S.E.M., n=8) after oral administration of 12 mg of diltiazem per kg of rat with single dose co-administration of 6 mg/kg caffeine | 91 |
| Figure 5.3 | Mean plasma concentration versus time profiles of diltiazem (mean±S.E.M., n=8) after oral administration of 12 mg of diltiazem per kg of rat with multiple dose co-administration of 6 mg/kg caffeine | 92 |
| Figure 5.4 | Mean plasma concentration versus time profiles of rifampicin (mean±S.E.M., n=8) after oral administration of 10 mg of rifampicin per kg of rat with single dose co-administration of 6 mg/kg caffeine | 96 |

| | | |
|------------|--|-----|
| Figure 5.5 | Mean plasma concentration versus time profiles of rifampicin (mean±S.E.M., n=8) after oral administration of 10 mg of rifampicin per kg of rat with multiple dose co-administration of 6 mg/kg caffeine | 97 |
| Figure 5.6 | Chromatograms for the analysis of caffeine in (a) human blank plasma, (b) rat blank plasma, (c) human blank spiked with 2000.0 ng/ml caffeine and 25.0 µg/ml BHET and (d) rat plasma containing 4050.1 ng/ml caffeine 30 minutes after oral administration of 6.0 mg/kg caffeine (y-axis, attenuation 6; x-axis, chart speed 2.5 mm/min). Peak 1 = BHET, peak 2 = caffeine | 102 |
| Figure 5.7 | Mean plasma concentration versus time profiles of caffeine (mean±S.E.M., n=6) obtained from two separate administrations of 6 days apart | 106 |
| Figure 5.8 | Mean plasma concentration versus time profiles of caffeine (mean±S.E.M., n=6) obtained on day 1 and day 7 from daily dosing for 7 days | 108 |
| Figure 6.1 | Chemical structure of piperine | 113 |
| Figure 6.2 | Mean plasma concentration versus time profiles of diltiazem (mean±S.E.M., n=8) after oral administration of 12 mg of diltiazem per kg of rat with single dose co-administration of 20 mg/kg piperine | 124 |
| Figure 6.3 | Mean plasma concentration versus time profiles of diltiazem (mean±S.E.M., n=8) after oral administration of 12 mg of diltiazem per kg of rat with multiple dose co-administration of 20 mg/kg piperine | 125 |
| Figure 6.4 | Mean plasma concentration versus time profiles of rifampicin (mean±S.E.M., n=8) after oral administration of 10 mg of rifampicin per kg of rat with single dose co-administration of 20 mg/kg piperine | 130 |

Figure 6.5 Mean plasma concentration versus time profiles of rifampicin 131
(mean±S.E.M., n=8) after oral administration of 10 mg of rifampicin
per kg of rat with multiple dose co-administration of 20 mg/kg
piperine

LIST OF EQUATIONS

Page

4

1.1

LIST OF SYMBOLS, ABBREVIATIONS OR NOMENCLATURE

| Abbreviation | Full description |
|------------------|--|
| ABC | ATP-binding cassette |
| ABCB1 | ATP-binding cassette 1 |
| ACE | Angiotensin-converting enzyme |
| ACN | Acetonitrile |
| AEC | Animal Ethics Committee |
| AHH | Arylhydrocarbon hydroxylase |
| ANOVA | Analysis of variance |
| AR | Analytical Reagent |
| ATP | Adenosine triphosphate |
| AUC | Area under the plasma concentration-time curve |
| AUC_{0-t} | Area under the plasma concentration-time curve from time zero to the last sampling time, t |
| AUC_{0-4h} | Area under the plasma concentration-time curve from time zero to the last sampling time, 4 hours after dosing |
| AUC_{0-8h} | Area under the plasma concentration-time curve from time zero to the last sampling time, 8 hours after dosing |
| AUC_{0-16h} | Area under the plasma concentration-time curve from time zero to the last sampling time, 16 hours after dosing |
| $AUC_{0-\infty}$ | Area under the plasma concentration-time curve from time zero to infinity |
| $AUC_{t-\infty}$ | Area under the plasma concentration-time curve from time t to infinity |
| BCRP | Breast cancer-resistance protein |

| | |
|------------------|---|
| BHET | β -hydroxyethyltheophylline |
| cDNAs | Copied deoxynucleic acids |
| C.I. | Confidence interval |
| C_{max} | Peak plasma concentration |
| C_{tt} | Plasma concentration at the last sampling point |
| C.V. | Coefficient of variation |
| CYP1A1/2 | Cytochrome P450 subfamily 1A1/2 |
| CYP2A6 | Cytochrome P450 subfamily 2A6 |
| CYP2C8/9/10/19 | Cytochrome P450 subfamily 2C8/9/10/19 |
| CYP2D6 | Cytochrome P450 subfamily 2D6 |
| CYP2E1 | Cytochrome P450 subfamily 2E1 |
| CYP3A | Cytochrome P450 subfamily 3A |
| CYP3A4 | Cytochrome P450 subfamily 3A4 |
| D | Diffusion coefficient |
| Da | Dalton |
| FMO | Flavin-containing monooxygenases |
| FPE | Fluid-phase endocytosis |
| GIT | Gastrointestinal tract |
| HCl | Hydrochloric acid |
| HPLC | High performance liquid chromatography |
| HUGO | Human Genome Organization |
| IC ₅₀ | 50% inhibitory concentrations |
| IPA | Isopropyl alcohol |
| K_e | Elimination rate constant |
| LD ₅₀ | 50% lethal dose |
| LLC-GA5-COL150 | LLC-PK1 transfected with human MDR1 cDNA and over-expressing human P-gp |

| | |
|------------------|--|
| LLC-PK1 | Porcine kidney epithelial cell line |
| Log P | Logarithm of octanol/water partition coefficient |
| MDR | Multidrug resistance |
| MDR1/2 | Multidrug resistance 1/2 |
| mdr1a/1b/2 | Rodent multidrug resistance 1a/1b/2 |
| mRNA | Messenger ribonucleic acid |
| MRP | Multidrug resistance-associated protein |
| MRP1-5 | Multidrug resistance-associated protein family 1-5 |
| NaOH | Sodium hydroxide |
| NIH3T3/MDR1 | MDR1-over-expressing murine fibroblast cells |
| P | Partition coefficient |
| PEPT1 | Oligopeptide transporter 1 |
| P-gp | P-glycoprotein |
| R | Diffusion rate |
| r | Correlation coefficient |
| RME | Receptor-mediated endocytosis |
| S.D. | Standard deviation |
| S.E.M. | Standard error of mean |
| SPE | Solid phase extraction |
| SXR | Steroid xenobiotic receptor |
| TEA | Triethylamine |
| TEER | Transepithelial electrical resistance |
| THF | Tetrahydrofuran |
| T _{max} | Time to reach peak plasma concentration |
| TPGS | Alpha-tocopheryl polyethylene glycol succinate |
| UV | Ultraviolet |
| USM | Universiti Sains Malaysia |

| | |
|---------------|-----------------------------|
| U.S. Pat. No. | United States Patent Number |
| VIS | Visible |
| v/v | Volume over volume |
| w/w | Weight over weight |
| w/v | Weight over volume |

LIST OF APPENDICES

| | Page | |
|------------------|---|-----|
| Appendix 4.1 | Approval letter from Animal Ethics Committee (AEC) of USM on the study of food-drug interaction between Capsaicin and Diltiazem [Chapter 4, section 4.3.1(b)] | 161 |
| Appendix 4.2 | Approval letter from Animal Ethics Committee (AEC) of USM on the study of food-drug interaction between Capsaicin and Rifampicin [Chapter 4, section 4.3.2(b)] | 162 |
| Appendix 4.3 (a) | Plasma diltiazem concentration values of individual rats after oral administration of 12 mg of diltiazem per kg of rat with single dose co-administration of 4 mg/kg capsaicin | 163 |
| Appendix 4.3 (b) | Plasma diltiazem concentration values of individual rats after oral administration of 12 mg of diltiazem per kg of rat without single dose co-administration of 4 mg/kg capsaicin | 163 |
| Appendix 4.4 (a) | Plasma diltiazem concentration values of individual rats after oral administration of 12 mg of diltiazem per kg of rat with multiple dose co-administration of 4 mg/kg capsaicin | 164 |
| Appendix 4.4 (b) | Plasma diltiazem concentration values of individual rats after oral administration of 12 mg of diltiazem per kg of rat without multiple dose co-administration of 4 mg/kg capsaicin | 164 |
| Appendix 4.5 (a) | Plasma rifampicin concentration values of individual rats after oral administration of 10 mg of rifampicin per kg of rat with single dose co-administration of 4 mg/kg capsaicin | 165 |
| Appendix 4.5 (b) | Plasma rifampicin concentration values of individual rats after oral administration of 10 mg of rifampicin per kg of rat without single dose co-administration of 4 mg/kg capsaicin | 165 |

| | | |
|------------------|---|-----|
| Appendix 4.6 (a) | Plasma rifampicin concentration values of individual rats after oral administration of 10 mg of rifampicin per kg of rat with multiple dose co-administration of 4 mg/kg capsaicin | 166 |
| Appendix 4.6 (b) | Plasma rifampicin concentration values of individual rats after oral administration of 10 mg of rifampicin per kg of rat without multiple dose co-administration of 4 mg/kg capsaicin | 166 |
| Appendix 5.1 | Approval letter from Animal Ethics Committee (AEC) of USM on the study of food-drug interaction between Caffeine and Diltiazem [Chapter 5, section 5.3.1(b)] | 167 |
| Appendix 5.2 | Approval letter from Animal Ethics Committee (AEC) of USM on the study of food-drug interaction between Caffeine and Rifampicin [Chapter 5, section 5.3.2(b)] | 168 |
| Appendix 5.3 | Approval letter from Animal Ethics Committee (AEC) of USM on oral bioavailability study of caffeine in rats [Chapter 5, section 5.3.3(b)] | 169 |
| Appendix 5.4 (a) | Plasma diltiazem concentration values of individual rats after oral administration of 12 mg of diltiazem per kg of rat with single dose co-administration of 6 mg/kg caffeine | 170 |
| Appendix 5.4 (b) | Plasma diltiazem concentration values of individual rats after oral administration of 12 mg of diltiazem per kg of rat without single dose co-administration of 6 mg/kg caffeine | 170 |
| Appendix 5.5 (a) | Plasma diltiazem concentration values of individual rats after oral administration of 12 mg of diltiazem per kg of rat with multiple dose co-administration of 6 mg/kg caffeine | 171 |
| Appendix 5.5 (b) | Plasma diltiazem concentration values of individual rats after oral administration of 12 mg of diltiazem per kg of rat without multiple dose co-administration of 6 mg/kg caffeine | 171 |

| | | |
|------------------|--|-----|
| Appendix 5.6 (a) | Plasma rifampicin concentration values of individual rats after oral administration of 10 mg of rifampicin per kg of rat with single dose co-administration of 6 mg/kg caffeine | 172 |
| Appendix 5.6 (b) | Plasma rifampicin concentration values of individual rats after oral administration of 10 mg of rifampicin per kg of rat without single dose co-administration of 6 mg/kg caffeine | 172 |
| Appendix 5.7 (a) | Plasma rifampicin concentration values of individual rats after oral administration of 10 mg of rifampicin per kg of rat with multiple dose co-administration of 6 mg/kg caffeine | 173 |
| Appendix 5.7 (b) | Plasma rifampicin concentration values of individual rats after oral administration of 10 mg of rifampicin per kg of rat without multiple dose co-administration of 6 mg/kg caffeine | 173 |
| Appendix 5.8 (a) | Plasma caffeine concentration values of individual rats after an oral administration of 6 mg of caffeine per kg of rat on day 1 for caffeine single repeated administration study | 174 |
| Appendix 5.8 (b) | Plasma caffeine concentration values of individual rats after an oral administration of 6 mg of caffeine per kg of rat on day 7 for caffeine single repeated administration study | 174 |
| Appendix 5.9 (a) | Plasma caffeine concentration values of individual rats after an oral administration of 6 mg of caffeine per kg of rat on day 1 for caffeine multiple administration study | 175 |
| Appendix 5.9 (b) | Plasma caffeine concentration values of individual rats after an oral administration of 6 mg of caffeine per kg of rat on day 7 for caffeine multiple administration study | 175 |
| Appendix 6.1 | Approval letter from Animal Ethics Committee (AEC) of USM on the study of food-drug interaction between Piperine and Diltiazem [Chapter 6, section 6.3.1(b)] | 176 |

| | | |
|------------------|---|-----|
| Appendix 6.2 | Approval letter from Animal Ethics Committee (AEC) of USM on the study of food-drug interaction between Piperine and Rifampicin [Chapter 6, section 6.3.2(b)] | 177 |
| Appendix 6.3 (a) | Plasma diltiazem concentration values of individual rats after oral administration of 12 mg of diltiazem per kg of rat with single dose co-administration of 20 mg/kg piperine | 178 |
| Appendix 6.3 (b) | Plasma diltiazem concentration values of individual rats after oral administration of 12 mg of diltiazem per kg of rat without single dose co-administration of 20 mg/kg piperine | 178 |
| Appendix 6.4 (a) | Plasma diltiazem concentration values of individual rats after oral administration of 12 mg of diltiazem per kg of rat with multiple dose co-administration of 20 mg/kg piperine | 179 |
| Appendix 6.4 (b) | Plasma diltiazem concentration values of individual rats after oral administration of 12 mg of diltiazem per kg of rat without multiple dose co-administration of 20 mg/kg piperine | 179 |
| Appendix 6.5 (a) | Plasma rifampicin concentration values of individual rats after oral administration of 10 mg of rifampicin per kg of rat with single dose co-administration of 20 mg/kg piperine | 180 |
| Appendix 6.5 (b) | Plasma rifampicin concentration values of individual rats after oral administration of 10 mg of rifampicin per kg of rat without single dose co-administration of 20 mg/kg piperine | 180 |
| Appendix 6.6 (a) | Plasma rifampicin concentration values of individual rats after oral administration of 10 mg of rifampicin per kg of rat with multiple dose co-administration of 20 mg/kg piperine | 181 |
| Appendix 6.6 (b) | Plasma rifampicin concentration values of individual rats after oral administration of 10 mg of rifampicin per kg of rat without multiple dose co-administration of 20 mg/kg piperine | 181 |

PENGARUH INTERAKSI MAKANAN DAN DRUG TERHADAP BIOKEPEROLEHAN DRUG ORAL

ABSTRAK

Kajian in dijalankan untuk mengkaji potensi interaksi di antara juzuk makanan umum (capsaicin; kafein; piperine) dan drug yang merupakan substrat kepada P-glikoprotein (P-gp) dan/atau Sitokrom P450 subfamili CYP3A (CYP3A). Capsaicin dijumpai dalam buah *Capsicum* (cili), manakala kafein dijumpai dalam pelbagai makanan dan minuman seperti kopi, di samping itu piperine adalah alkaloid utama daripada lada. Diltiazem dan rifampicin yang merupakan substrat kepada kedua-dua P-gp dan CYP3A telah digunakan sebagai drug model. Dua kaedah kromatografi cecair prestasi tinggi yang mempunyai kespesifikan dan sensitif telah berjaya dibangunkan untuk menentukan kepekatan kedua-dua sebatian tersebut dalam plasma tikus/manusia. Kedua-dua kaedah juga mempunyai kejituan dan kepersisihan yang bagus.

Semua ujikaji dijalankan mengikut rekabentuk bersilang dua-hala dengan menggunakan tikus Sprague-Dawley, yang mana kedua-dua drug diberi bersama atau tanpa juzuk makanan. Pengaruh setiap juzuk makanan dikaji dengan diberi sebagai satu dos dan juga dos berulang selama 7 hari. Dalam ujikaji satu dos, drug model diberi setengah jam selepas diberi juzuk makanan manakala dalam ujikaji dos berulang, drug model diberi setengah jam selepas dos terakhir bagi juzuk makanan. Dos-dos diltiazem, rifampicin, capsaicin, kafein dan piperine yang diberi kepada tikus adalah berdasarkan berat badan tikus iaitu 12, 10, 4, 6 dan 20 mg/kg masing-masing. Dalam ujikaji capsaicin, tidak ada peningkatan signifikan ($p>0.05$) dalam biokeperolehan untuk kedua-dua diltiazem dan rifampicin apabila tikus diberikan satu dos ataupun 7 dos berulang setiap hari, walaupun biokeperolehan didapati meningkat sebanyak 1.1 dan 1.2 kali masing-masing. Namun demikian, dalam kes dengan kafein, takat penyerapan

diltiazem dan rifampicin adalah didapati meningkat secara signifikan ($p < 0.05$) sebanyak 1.4 dan 1.5 kali masing-masing apabila diberi bersama satu dos kafein. Dalam dos berulang dengan kafein, biokeperolehan kedua-dua drug model juga didapati meningkat secara signifikan ($p < 0.05$) sebanyak 1.4 dan 1.3 kali masing-masing. Yang menariknya, di dalam satu ujikaji yang berasingan di mana tikus diberikan kafein sahaja sebanyak 7 dos, biokeperolehannya yang didapati selepas dos terakhir adalah berkurangan secara signifikan ($p < 0.05$) jika dibandingkan dengan yang didapati selepas dos pertama. Walaubagaimanapun, tidak ada perbezaan yang signifikan ($p > 0.05$) pada biokeperolehan yang diperolehi apabila hanya dua dos berasingan yang diberikan dengan diperantarakan sebanyak 6 hari. Walaupun demikian, kedua-dua dos sekali dan dos berulang dengan kafein didapati masih mempengaruhi biokeperolehan kedua-dua drug yang merupakan substrat kepada P-gp dan CYP3A secara signifikan.

Untuk piperine, walaupun ia sudah dihayati sebagai perangsang biokeperolehan, tidak ada peningkatan signifikan ($p > 0.05$) dalam biokeperolehan yang didapati untuk kedua-dua diltiazem dan rifampicin dalam kajian ini, tanpa mengira piperine diberikan dalam satu dos ataupun dos berulang. Dengan itu, kegunaannya sebagai perangsang biokeperolehan masih ada kontroversi.

EFFECT OF FOOD-DRUG INTERACTION ON ORAL DRUG BIOAVAILABILITY

ABSTRACT

The present study was conducted to investigate potential interactions between some common food constituents (capsaicin; caffeine; piperine) and substrate drugs of P-glycoprotein (P-gp) and/or Cytochrome P450 subfamily CYP3A (CYP3A). Capsaicin is found in *Capsicum* fruits (chillies), whereas caffeine is found in many common food and beverages like coffee while piperine is a major alkaloid from pepper. Diltiazem and rifampicin, which are known substrates of both P-gp and CYP3A, were used as model drugs. Two high-performance liquid chromatographic (HPLC) methods with the required specificity and sensitivity were successfully developed for determination of the two respective compounds in rat/human plasma. Both methods also possessed good precision and accuracy.

All studies were carried out according to a 2-way crossover study design using Sprague-Dawley rats, where both drugs were administered with and without co-administration of each food constituent. The influence of each food constituent was studied by giving it as a single dose as well as 7 daily doses. In the single dose study, the model drugs were given half an hour after the food constituent while in the multiple dose study, they were given half an hour after the last dose of the food constituent. The respective doses of diltiazem, rifampicin, capsaicin, caffeine and piperine used were 12, 10, 4, 6 and 20 mg/kg body weight of the rats.

In the study with capsaicin, no significant increase ($p > 0.05$) in bioavailability was observed with both diltiazem and rifampicin when the animals were treated with either a single capsaicin dose or 7 daily consecutive doses, although their bioavailability were found to be slightly increased by 1.1 and 1.2 times, respectively. However, in the case of

caffeine, the extent of absorption of diltiazem and rifampicin was found to be significantly increased ($p < 0.05$) by 1.4 and 1.5 times, respectively when co-administered with a single caffeine dose. On multiple caffeine administration, the bioavailability of the two model drugs was also found to be significantly ($p < 0.05$) increased by 1.4 and 1.3 times, respectively. Interestingly, in a separate study where the rats were given 7 daily doses of caffeine alone, its bioavailability determined after the last dose was found to be significantly reduced ($p < 0.05$) compared to that determined after the first dose. However, no significant difference ($p > 0.05$) in bioavailability was observed when only two doses were given 6 days apart. Nevertheless, both single and multiple dose administration of caffeine were found to significantly alter the bioavailability of the two P-gp and CYP3A substrate drugs.

As for piperine, even though it has been patented as a bioavailability enhancer, no significant increase in bioavailability ($p > 0.05$) was observed with both diltiazem and rifampicin in the present study, whether piperine was given as a single dose or in multiple doses. Thus, its utility as a bioavailability enhancer is controversial.

CHAPTER 1

INTRODUCTION

1.1 General Introduction

Bioavailability refers to the rate and extent of an administered dose of a drug which reaches the systemic circulation intact (Ashford, 2002a). To date, the major and most preferred way of delivering drugs to systemic circulation is still via the oral route as it is safer, more efficient and more easily accessible with minimal discomfort to the patients compared to other routes of drug administration (Petri and Lennernäs, 2003).

It has been well established that bioavailability of orally administered drugs can be influenced by various factors such as the physiological conditions of the gastrointestinal tract, physicochemical properties of the drug as well as formulation factors. In recent years, extensive research on drug-drug interactions has revealed the immense impact of the previously unknown transporters and enzymes in the enterocytes of the gastrointestinal tract on the oral bioavailability of drugs with varied characteristics (Mizuno *et al.*, 2003; Chan *et al.*, 2004). Further investigations even uncovered that food and herb constituents were capable of modulating the transporters as well as the enzymes, hence affecting the oral bioavailability of concomitantly administered drugs (Deferme and Augustijns, 2003; Goosen *et al.*, 2004).

1.2 Drug transport across cell membranes

Following oral administration, drug molecules have to dissolve in the gastrointestinal fluid and cross the gastrointestinal membrane in order to be channelled via the hepatic portal vein to the liver before gaining access into the systemic circulation. Moreover, they must be absorbed adequately and efficiently in order to exert satisfactory therapeutic effects. Nevertheless, before reaching the portal circulation, dissolved drug molecules have to penetrate the mucous layer, the apical cell surface, the fluid within

the cell, the basolateral membrane, the basement membrane, the external capillary membrane, the cytoplasm of the capillary and finally the inner capillary membrane (Ashford, 2002b).

A schematic diagram of pathways mediating the transmembrane transport cited from Hämäläinen and Frostell-Karlsson (2004) is shown in Figure 1.1. Drug transport across the biological membrane occurs via two main routes, namely the paracellular and the transcellular pathways. Mechanisms involved in drug transport will be further discussed in the following sections.

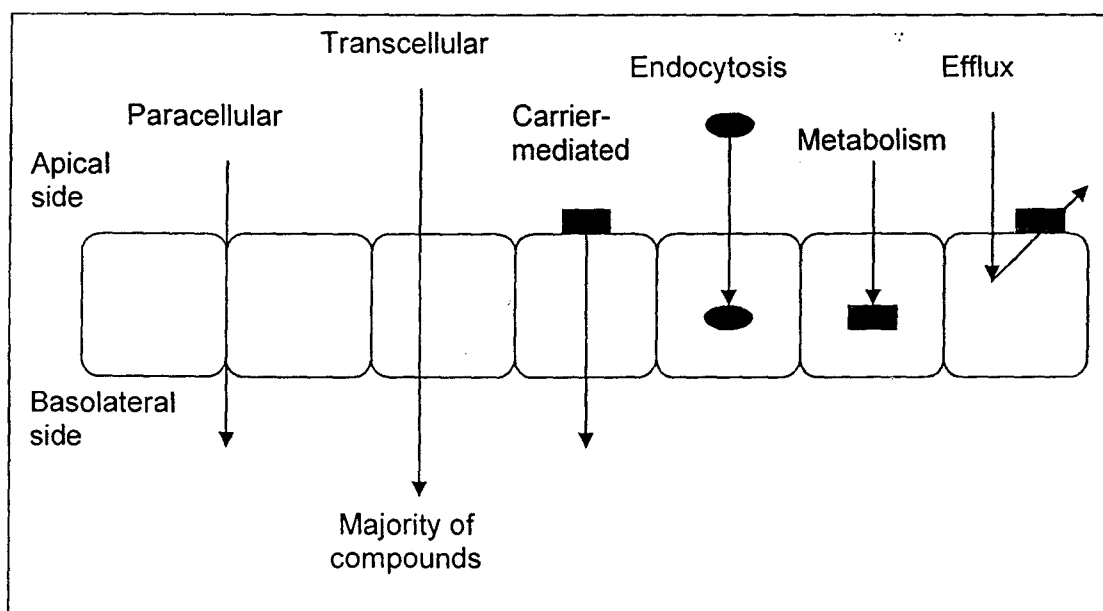

Figure 1.1 Mechanisms in membrane permeation

1.2.1 Paracellular pathway

The paracellular pathway involves passage of small molecules and water soluble substances such as urea, through the aqueous pores between the epithelial cells by simple diffusion. This pathway is especially important for transport of sugars and ions such as calcium at concentrations above the capacity of their carriers (Ashford, 2002b). Also, transport of compounds via this pathway is greatly influenced by molecular weight, transport volume and molecular charge (Ungell and Karlsson, 2003).

The poor absorption of compounds transported through the paracellular pathway is mainly attributed to the much smaller surface area presented by the pores compared to that of the membrane, limited dimension of the pore as well as restriction by the tight junction along the apical membrane surface (Smith *et al.*, 2001). Moreover, the intercellular spaces occupy only about 0.01% of the total surface area of the epithelium (Ashford, 2002b). Generally, the molecular weight cut-off values for transport via this pathway in the small and large intestines are approximately 400 g/mol and 300 g/mol, respectively (Ungell and Karlsson, 2003). Thus, as the number and size of the pores between the epithelial cells decrease along the gastrointestinal tract, the contribution of this pathway to drug absorption also becomes negligible at the more distal part of the gastrointestinal tract.

1.2.2 Transcellular pathway

Transport of molecules across the biological membrane via transcellular pathway is regarded as the main route of absorption for many drugs. The transcellular pathway involves transport of relatively large molecules (above 200 Da) across biological membrane via simple passive diffusion, carrier-mediated transport and vesicular transport (Ashford, 2002b).

1.2.2.1 Passive diffusion

Passive diffusion is a process driven by a concentration gradient (activity gradient) (Mayersohn, 2002). Drug molecules diffuse from the region of high concentration (e.g. gut lumen) to that of low concentration (e.g. blood capillary). The rate of drug transport is governed by the physicochemical properties of the drug, the nature of the membrane and the concentration gradient across the membrane. Often, passive diffusion across the gastrointestinal membrane is expressed mathematically according to Fick's first law of diffusion which states that diffusion rate R (in moles s^{-1}) is proportional to the concentration gradient dC/dX :

$$R = -DA \frac{dC}{dX} \quad (1.1)$$

Where dC is the concentration difference between the outside and inside of the membrane, and dX is the thickness of the membrane. A is the area of membrane over which diffusion occurs, and D is a constant (for specific molecule in a specific environment) called diffusion coefficient (Washington *et al.*, 2001a). It is apparent from Equation (1.1) that the rapid rate of passive diffusion is attributed to large surface area which indicates that the small intestine is the major site of drug absorption, owing to the presence of the large number of villi and microvilli (Ashford, 2002b). In addition, enhanced transport of drug molecules via passive diffusion can also be achieved by increasing the concentration gradient as well as selecting a drug molecule with higher D value (Washington *et al.*, 2001a).

There are two main factors governing the diffusion coefficient (D), namely, the solubility and molecular weight of the drug. The relative solubility of a drug molecule in aqueous or oily environment is expressed using the logarithm (\log) of the partition coefficient, P , which describes the extent of the drug distribution between a pair of solvents (usually water and an oily solvent such as octanol) (Washington *et al.*, 2001a). Molecules with very low $\log P$ values are known to be hydrophilic, and hence difficult to dissolve in the lipid bilayer of the gastrointestinal membrane. On the contrary, molecules with very high $\log P$ values are too lipophilic to dissolve in the extracellular fluid or have too strong affinity with the lipid bilayer, causing a phenomenon known as solubility-limited absorption (Washington *et al.*, 2001a). Therefore, a drug needs to have sufficient lipophilicity in order to partition into the membrane, yet sufficiently soluble in aqueous environment so that it can dissolve in gastrointestinal fluid and also partition out of the membrane readily into the blood circulation.

Apart from solubility, molecular weight of a drug was also found to influence the diffusion coefficient. In general, drugs with a smaller molecular weight but similar log P values will diffuse faster across the membrane than those with a larger molecular weight (Washington *et al.*, 2001a).

1.2.2.2 Carrier-mediated transport

Although majority of drugs are transported through passive diffusion, carrier-mediated transport has been found to play a vital role in transporting certain drugs as well as nutrients from the gastrointestinal lumen across the epithelial cells. There are two main carrier-mediated transports, namely active transport and facilitated diffusion or transport (Ashford, 2002b). In carrier-mediated transport, a drug-carrier complex forms at the apical side of the membrane and the complex subsequently moves across the cell membrane to release the drug into the other side of the membrane. The carrier then returns to its initial position to form a complex again with another drug molecule or other compounds to sustain the process. A schematic diagram of carrier-mediated transport is shown in Figure 1.2.

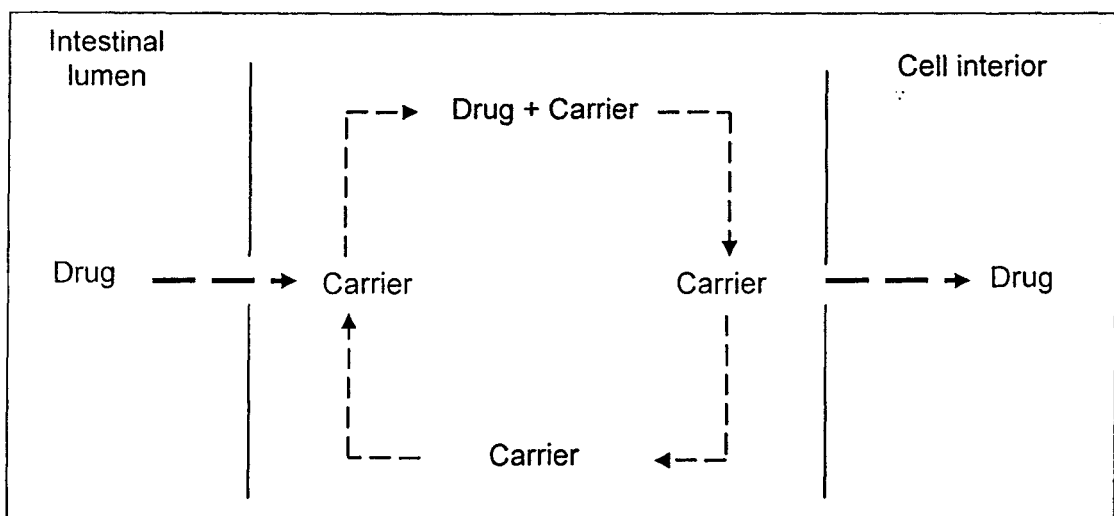

Figure 1.2 Diagrammatic representation of carrier-mediated transport of a drug across a cell membrane (Ashford, 2002b)

1.2.2.2.1 Active transport

In contrast to passive diffusion, active transport is characterised by transport of drug molecules against the concentration gradient that is from a region of low concentration to that of high concentration. Therefore, it is an energy-consuming process (Shargel and Yu, 1985) and the energy is derived from either the hydrolysis of intracellular adenosine triphosphate (ATP) or the transmembranous sodium gradient and/or electrical potential (Washington *et al.*, 2001a; Ashford, 2002b).

Various nutrients such as amino acids, sugars, electrolytes, vitamins and bile salts as well as peptide-like drugs such as the penicillins, cephalosporins, angiotensin-converting enzyme (ACE) inhibitors and renin inhibitors are actively carried by transporters in the small intestine, present on either the apical (brush border) or the basolateral membrane (Shin *et al.*, 2003). Transporters involved as either influx or efflux pumps involved in the active transport process will be further detailed in section 1.4.

Unlike passive diffusion whereby the rate of absorption is directly proportional to the concentration of the absorbable species of the drug at the absorptive site, the rate of drug absorption in active transport is only proportional to the drug concentration at relatively low concentrations. At higher drug concentrations, the carriers can become saturated and further increases in drug concentration will not increase the rate of absorption (Ashford, 2002b).

1.2.2.2.2 Facilitated diffusion or transport

As facilitated diffusion or transport carries drugs across the membrane along a concentration gradient, it does not require energy input (Shargel and Yu, 1985). However, as carriers are also involved, the transport is therefore saturable and selective. Besides being saturable, the rate of facilitated diffusion is also affected by molecular weight as well as polarity of the molecule. Furthermore, it shows competitive

kinetics for drugs of similar structures like the active transport system (Shargel and Yu, 1985). However, facilitated diffusion seems to play a very minor role in drug absorption (Ashford, 2002b).

1.2.2.3 Vesicular transport

Membrane transport via diffusion or transporters is only viable for small molecules. Large molecules such as macromolecules and particles are internalised by a completely different mechanism in which a portion of the membrane extends and envelops the object, drawing it into the cell to form a vacuole. This process is known as cytosol (Washington *et al.*, 2001a). Endocytosis is the process in which the membrane surface invaginates and pinches off, creating small intracellular vesicles that enclose a volume of material. These compounds will then be transferred to either other vesicles or lysosomes that will digest the vesicles. Materials that manage to escape the digestion migrate to the basolateral surface of the cell where it is exocytosed. Enterocytes, (the cells lining the epithelium of the gastrointestinal tract) also possess vesicular transport process facilitating drug absorption (Hidalgo, 2001) which includes fluid-phase endocytosis (FPE) or pinocytosis, receptor-mediated endocytosis (RME), phagocytosis and transcytosis.

Pinocytosis or FPE involves engulfment of small droplets of extracellular fluid by membrane vesicle. Fat soluble vitamins A, D, E and K as well as some peptides and proteins are absorbed via this slow process (Hidalgo, 2001; Ashford, 2002b). Receptor-mediated endocytosis is usually meant only for the mucosal permeation of macromolecules, but not small molecules. Receptors on the membrane have the capability to bind with some ligands followed by clustering of the receptor-ligand complex into clathrin-coated pits (Hidalgo, 2001). The receptors will then dissociate from the ligands in the endosomes and be recycled back into the plasma membrane.

Phagocytosis involves engulfment of particles larger than 500 nm by the cell membrane to form a phagosomes whereas transcytosis is a mechanism in which a cell encloses extracellular material in an invagination of the cell membrane to form a vesicle, then moves the vesicle across the cell to eject the material through the opposite cell membrane by the reverse process (Ashford, 2002b). The most common phagocytotic process occurs when white blood cells (macrophage) engulf foreign compounds such as viruses and bacteria. This process is also very important for absorption of vaccines from the gastrointestinal tract (Washington *et al.*, 2001a; Ashford, 2002b).

1.3 Oral drug absorption from the gastrointestinal tract

The gastrointestinal tract (GIT) is a highly specialised region of the body which is involved in the processes of secretion, digestion and absorption. The GIT consists of three major anatomical regions, namely the stomach, small intestine and large intestine (colon). As mentioned earlier, oral administration is the most convenient and frequently used route of drug administration. Drugs in oral dosage form have to be absorbed from the GIT before entering the systemic circulation via the portal vein to exert therapeutic effects. As drugs descend through regions of the GIT, numerous factors such as different pH environment, enzymes, electrolytes, fluidity and surface features can limit the rate and extent of intact drug entering the systemic circulation.

1.3.1 The stomach

Stomach is the preparative as well as primary storage region of the GIT. It acts as a reservoir which processes food into fluid chyme to facilitate nutrient absorption from the small intestine and controls the rate of nutrient delivery to the small intestine. The stomach can be divided into two major regions, i.e. the fundus and body that make up the proximal region, and the antrum and pylorus that make up the distal region.

Since ingested food is not sterile, stomach produces acid which has bacteriostatic activity. Besides that, the acid also helps to adjust the gastric pH to an appropriate level for pepsin to function (Washington *et al.*, 2001b). The surface of stomach, namely the mucosa (mucous membrane), is lined with a single layer of simple columnar epithelium which is protected from the acidic environment by a layer of thick mucus secreted by the columnar cells. This mucus also lubricates food masses and facilitates movement of food within the stomach (Washington *et al.*, 2001b). Gastric pH is influenced by acid secretion as well as gastric content, and is not uniform within the stomach.

When an orally administered drug reaches the stomach, it is exposed to a highly variable environment in terms of food content and pH. Thus, the oral bioavailability can be affected by rate of gastric emptying, the presence of food or other drugs, the dosage form as well as the drug carrier (Washington *et al.*, 2001b).

The time taken for a dosage form to traverse the stomach is often expressed as the gastric residence time, gastric emptying time or gastric emptying rate (Ashford, 2002b). As drug absorption occurs mainly in the small intestine, the duration of drug residence in the stomach can influence the rate as well as the extent of drug absorption. Apart from that, the longer the drug remains in the stomach, the higher the chance of it being exposed to the highly acidic environment and the enzymes of the stomach that might cause drug degradation. Often, factors that cause variability in gastric emptying rate are complex and multidimensional, and these include the type of dosage form, presence of food, disease state, viscosity of gastric content, emotional state and postural position.

In general, an oily meal may delay the gastric emptying time, thus the drug absorption. However, the extent of food facilitating drug absorption also depends on other factors such as the physicochemical properties of the drug, dose, dosage form, time of drug administration relative to food intake, amount and type of food ingested (Mayersohn,

2002). Posture after oral drug administration was also found to affect the drug absorption. For example, lying down decreased the rate of gastric emptying compared to sitting upright whereas combination of sitting and standing was found to produce the most rapid rate of gastric emptying. It was reported that administration of acetaminophen and nifedipine resulted in greater plasma concentrations when given to subjects lying on their right or standing compared to those lying on their left (Renwick *et al.*, 1992; Washington *et al.*, 2001b; Mayersohn, 2002).

1.3.2 Small intestine

The small intestine is the longest section of the GIT, comprising of 3 regions, namely the duodenum (200-300 mm), the jejunum (2 m) and the ileum (3 m), and is most essential in drug and nutrient absorption. The surface of small intestine which consists of fold of Kerkring (folding of the epithelium, projecting into the lumen), villi (finger-like projections of epithelial surface) and microvilli (apical brush border membrane of the enterocytes) provides a relatively large surface area for absorption within the small abdominal volume (Washington *et al.*, 2001c). The surface area of the small intestine is increased by about 600 times compared to that of a simple cylinder of similar dimension due to the presence of these special structures.

The intestine has diverse functions which range from the mediation of the absorption of nutrients, waters and electrolytes, to the filtration of the foreign toxic compounds out of the body. In this regard, the intestinal epithelium is equipped with a complex structure of various types of cells such as the goblet cells, endocrine cells, tuft or calveolated cells and the absorptive cells (Washington *et al.*, 2001c). The most common type of epithelial cells is the absorptive cells or the enterocytes. The enterocytes are tall and columnar in shape, lining the epithelium to form a continuous single-cell thick surface, and are structurally supported by lamina propria (consisting of blood vessels, lymph and nerves).

Compounds must be able to cross the enterocytes to gain entry into the lamina propria in order to be absorbed into the bloodstream.

However, before reaching the enterocytes, several features of the intestinal epithelium not only inhibit the uptake of drug molecules, but also facilitate drug elimination by expelling them back into the lumen. The unstirred water layer or aqueous boundary layer refers to the stagnant layer of water, mucus and glycocalyx (a web of branching which is formed by a layer of mucopolysaccharides) adjacent to the intestinal wall (Ashford, 2002b). This mucus layer serves as barrier to drug diffusion by complexing with some drug molecules hence impeding drug absorption. Another restriction by epithelial cells in controlling molecule uptake can be represented by the tight junction. Apically located tight junctions limit paracellular transport especially compounds with molecular weights of more than 200 Da (Ashford, 2002b).

Absorption of certain essential substances is facilitated by the presence of selective influx transport proteins in the enterocytes, such as the amino acid and monosaccharide transporters (van Asperen *et al.*, 1998a). However, there are also efflux mechanisms located in the apical membrane of the enterocytes which counter-transport a broad range of structurally unrelated compounds back into the gastrointestinal lumen, and hence, limiting the oral bioavailability of many drugs. P-glycoprotein (P-gp) is the most studied member of apical efflux transporters, which belongs to the multidrug resistance (MDR) subfamily (Higaldo, 2001). Other apical membrane efflux transporters include the multidrug resistance-associated protein (MRP) and breast cancer-resistance protein (BCRP) families.

In addition to transporters, another biochemical barrier to drug absorption is the drug-metabolising enzymes. Almost all the drug-metabolising enzymes present in the liver are also found in the small intestine but at much lower levels (Peters and Kremers,

1989; Shimada *et al.*, 1994). The existence of cytochrome P450 superfamily enzymes in the enterocytes of the small intestine becomes critical when more than 50% of drugs are recognised to be substrates of these enzymes (Wacher *et al.*, 1995). Both transporters and enzymes may contribute significantly to poor oral drug bioavailability and their interactions will be further discussed in section 1.4 and 1.4.3, respectively.

1.3.3 Large intestine

The large intestine or often referred to as the colon, has two major functions, i.e. to absorb water and electrolytes as well as to store faecal material before elimination (Mayersohn, 2002). It is structurally similar to the small intestine but is lacking in the special feature, villi. Functionally, colon can be differentiated into two parts, the proximal segment (which includes the caecum, ascending colon and portions of the transverse colon) primarily for absorption; and the distal segment (which includes the transverse and descending colon, the rectum as well as the anus, terminating at the internal anal sphincter) which is mainly concerned for storage and mass movement of faecal materials (Mayersohn, 2002).

The colon is found to be permanently colonised by massive amount of different bacteria flora. Enzymes produced by the large colony of bacteria are capable of performing several metabolic reactions, including hydrolysis of fatty acid esters and reduction of inactive conjugated drugs to their active forms (Ashford, 2002b). Of late, much interest has been prompted in utilising these enzymes for drug targeting in the colon (Washington *et al.*, 2001d).

Major problems of colonic absorption are reduced surface area, wide lumen, sluggish movement, low volume of available dissolution fluid and reduced permeability of the colonic epithelium to polar compounds (Washington *et al.*, 2001d). In addition, gas bubbles present in the colon also reduce drug contact with mucosa of the large

intestine. However, colon is thought to provide a good environment, such as mild pH, little enzymatic activities, long transit time and no documented active transporters for drug absorption (Washington *et al.*, 2001d; Mayersohn, 2002). There are indeed active interests in delivery of drugs, especially peptides, to the colon for site-specific absorption by preventing release of drug from the dosage form before reaching the colon (Friend, 1991).

1.4 Role of transporters and metabolising enzymes in small intestine on oral drug bioavailability

Apart from the physical barrier of the GIT that can affect the oral bioavailability of drugs and nutrients, it is now well recognised that the enterocytes of the GIT, especially the small intestine, express a variety of transporters as well as metabolising enzymes. Many water-soluble compounds that include peptide analogues, nucleosides, amino acids, sugars, monocarboxylic acids, bile acids, fatty acids, organic cations and anions, phosphates and water-soluble vitamins are able to cross biological membranes via specialised carrier-mediated transport mechanisms (Shin *et al.*, 2003). It has now been discovered that these transporters are one of the determinant factors governing the pharmacokinetics of orally administered drugs (Ishikawa *et al.*, 2004). While influx transporters mediate absorption of drug molecules or nutrients through specialised carrier-mediated transport, there are also efflux transporters which on the other hand, extrude them out of the cells and back into the gastrointestinal lumen. There is a variety of transporters highly expressed in human intestine. Figure 1.3 shows the selected important transporters localised in the intestine epithelium as reviewed by Kruijtzter *et al.* (2002).

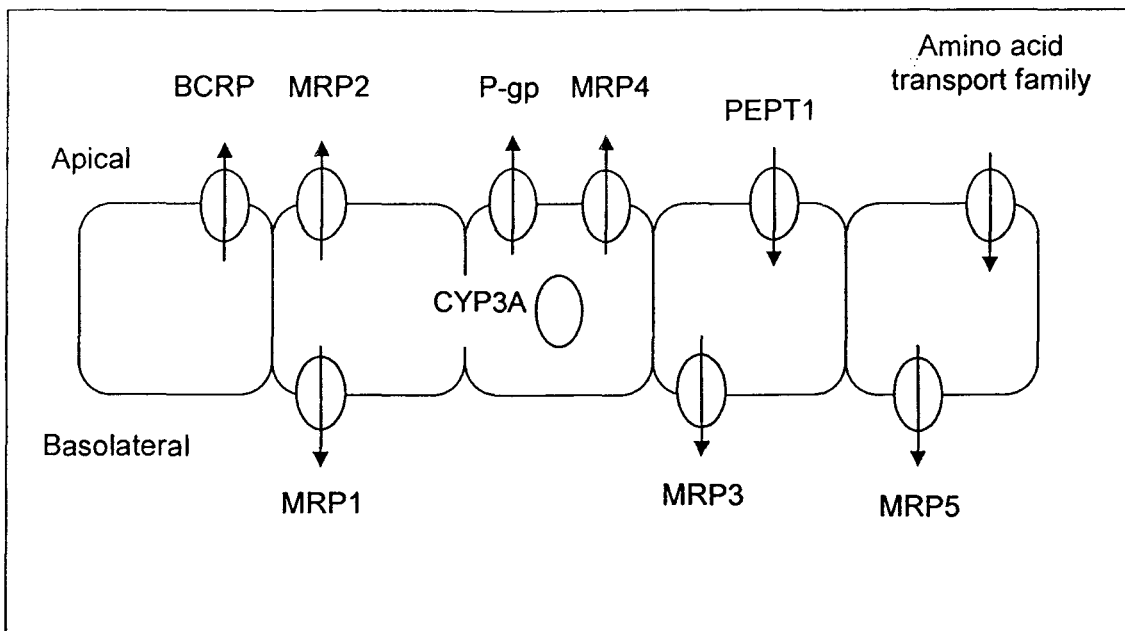

Figure 1.3 Localisation of selected transporters expressed in intestinal epithelial cells. (BCRP=breast cancer-resistance protein; MRP1-5=multidrug resistance protein family; P-gp=P-glycoprotein; PEPT1=oligopeptide transporter 1; CYP3A=metabolising enzyme belonging to Cytochrome P450 superfamily)

To date, many influx transporters expressed in the small intestine have been identified; these include peptide transporter, amino acid transporter, nucleoside transporter and glucose transporter. Among these transporters, intestinal oligopeptide transporter or di-/tripeptide transporter (PEPT1) has been most extensively studied and recognised in relation to mediating transport of many peptide-like drugs (Tsuji, 2002; Terada and Inui, 2004). PEPT1 is a proton coupled transporter that is known to play an essential role in the oral absorption of angiotensin-converting enzyme (ACE) inhibitors, renin inhibitors, antitumour drugs, thrombin inhibitors and a dopamine receptor antagonist (Rubio-Aliaga and Daniel, 2002). Other influx transporters such as amino acid transporters and nucleoside transporters also have been utilised for improving oral drug absorption. Amino acid analogues including L-4-chlorokynurenine, abapentin, baclofen and gabapentin are thought to be carried by amino acid transporters while nucleoside analogues such as azidothymidine, zalcitabine, cladribine and cytorabine depend on nucleoside transporters to be taken up across the epithelial cells (Shiri *et al.*, 2003).

Apart from influx transporters, known efflux transporters that are expressed in the epithelial cells of intestine include the multidrug-resistance protein (MDR), multidrug resistance-associated protein (MRP) and breast cancer-resistance protein (BCRP). These three transport proteins belong to the ABC (ATP-Binding Cassette) superfamily and are classified as the primary active efflux transporters. ABC superfamily is a large group of proteins comprising of membrane transporters, ion channels and receptors which show general sequence and structural homology (Higgins, 1992). These efflux transporters mediate cellular efflux in an active ATP-dependent manner against concentration gradient (Dietrich *et al.*, 2003). General structure of ABC transporters consists of 12 transmembrane regions, which are split into two 'halves', with each 'half' having a nucleotide binding domain. The exception is the ABC White subfamily, which is also known as 'half-transporters'. The half-transporters only have 6 transmembrane regions with the sole nucleotide binding domain (Hyde *et al.*, 1990). ABC transporters are primarily expressed in the brush border membrane of the enterocytes, where a variety of structurally diverse drugs, drug conjugates or metabolites and other compounds are extruded out of the cell, thus limiting the ultimate amount of drugs absorbed (Hunter *et al.*, 1993; Ambudkar *et al.*, 1999).

The MRP family of proteins has been shown to extrude organic anions including their conjugated metabolites, out of the cells (König *et al.*, 1999). MRP1 together with MRP3 and MRP5 are localised at the basolateral membranes of the epithelial cells, while MRP2 and MRP4 are expressed on the apical membranes (Büchler *et al.*, 1996; Peng *et al.*, 1999; Mottino *et al.*, 2000). To date, the role of MRP1 in mediating drug disposition has yet to be recognised. However, the presence of MRP1 did demonstrate its ability to confer drug resistance in a range of cancer cell lines, which contributes to drug resistance and might therefore, influence overall drug disposition. Meanwhile, of all the ABC transporters tested, MRP2 mRNA level was the highest found in human jejunum (Taipalensuu *et al.*, 2001). Also, MRP2 is able to transport anticancer drugs,

hence can also cause drug resistance like MRP1. Anticancer drugs that can be transported by MRP2 include methotrexate, vincristine, vinblastine, doxorubicin, epirubicin and possibly cisplatin and etoposide. Moreover, there is a fairly extensive overlapping of distribution as well as substrate specificity between MRP2 and P-gp. Hence, it is likely that these two proteins have considerable overlap in pharmacological as well as toxicological protective functions (Mottino *et al.*, 2000).

Breast cancer-resistance protein (BCRP), a 'half-transporter', which belongs to the ABC White family, was first identified and isolated from the human MCF-7 breast cancer cells by Doyle *et al.* (1998). Similar to P-gp and MRPs, BCRP was also found to be expressed in small intestine, colon and hepatocytes (Allikmets *et al.*, 1998; Maliepaard *et al.*, 2001). Thus, it was postulated that BCRP might play a similar role to P-gp as well as MRPs in limiting oral drug bioavailability. BCRP was found to be able to expel a range of drugs such as topotecan, mitocantrone, doxorubicin and daunorubicin (Allen *et al.*, 1999; Maliepaard *et al.*, 1999; Robey *et al.*, 2001).

In addition to the influx and efflux transporters, the intestinal epithelial cells are also rich in metabolising enzymes, especially those responsible for phase I oxidative metabolism, i.e. the cytochrome P450 superfamily (Mayersohn, 2002) although their level is lower than in liver (de Waziers *et al.*, 1990; Shimada *et al.*, 1994). The most abundant isoenzyme of the cytochrome P450 in human small intestine is CYP3A, being as high as 80 to 100% of the amount found in the liver (de Waziers *et al.*, 1990; Kolars *et al.*, 1992). Substrates of CYP3A may have poor bioavailability due to extensive intestinal and hepatic first-pass metabolism especially when it was later recognised that more than 50% of orally administered drugs might be substrates of this enzyme (Benet *et al.*, 1996). Due to overlapping substrate specificity and tissue distribution, it is conceivable that both P-gp and CYP3A could synergistically alter the oral bioavailability of a wide range of drugs (Wacher *et al.*, 1995; Schuetz *et al.*, 1996a; Watkins, 1997).

1.4.1 P-glycoprotein (P-gp)

To date, 52 ABC genes have been verified by the Human Genome Organization (HUGO) (Shin *et al.*, 2003). One of the most widely studied membrane efflux transporter is P-glycoprotein (P-gp; also known as MDR1, ABCB1) which belongs to the multidrug resistance protein subfamily of the ABC transporter superfamily. P-gp was first discovered and isolated by Juliano and Ling (1976) from colchicine-resistant Chinese hamster ovary cells. P-gp is a 170 kDa phosphorylated and glycosylated transmembrane protein with 1280 amino acids, arranged in two homologous halves of 610 amino acids each joined by a flexible linker consisting of 60 amino acids (Ambudkar *et al.*, 1999).

The two MDR genes that encode P-gp in human are MDR1 and MDR2 (also known as MDR3), whereas there are three genes that encode rodent P-gp, which are *mdr1a*, *mdr1b* and *mdr2*. Human MDR1 P-gp and rodent *mdr1a/1b* P-gp have been shown to confer multidrug resistance; whereas MDR2 P-gp in human and *mdr2* P-gp in rodent are responsible for transporting cellular phospholipids (Gottesman and Pastan, 1993).

Although P-gp tends to be over-expressed in tumour cells, it is also found in normal cells such as at the apical surface of epithelial cells in the liver (bile canaliculi), columnar mucosal cells in small intestine, capillary endothelium of the brain and testes, brush border of the proximal renal tubule and ductile cells of pancreas (Cordon-Cardo *et al.*, 1990; Gatmaitan and Arias, 1993; Lee *et al.*, 2001). The anatomical localisation of P-gp suggested that it can protect the body from toxic xenobiotics by excreting them into bile, urine, and intestinal lumen (Lin *et al.*, 1999). Mouly and Paine (2003) first reported that the expression of MDR1 P-gp increases from proximal to distal regions along the entire human small intestine. As for P-gp in rat intestine, it was later shown that the expression of *mdr1a* mRNA was moderate in the duodenum and jejunum, maximal in the ileum and lower through the proximal to the distal colon (Iida *et al.*, 2005).

Expression of P-gp in tumour cells results in active extrusion of a wide range of cancer chemotherapeutic drugs. Also, P-gp has been shown to transport a broad variety of pharmacological distinct agents used for treatment of hypertension, allergy, infection, immunosuppression, inflammation and neurological disorders (Lum *et al.*, 1993; van Asperen *et al.*, 1997; Verschraagen *et al.*, 1999; Seelieq and Landwojtowicz, 2000). Reviews by Schinkel and Jonker (2003) and Chan *et al.* (2004) reported that most substrates of P-gp are hydrophobic with molecular size ranging from less than 200 Da to almost 1900 Da, in addition to being amphipathic in nature. The list of substrates is being periodically expanded as more studies are being carried out.

Studies to determine the possible substrates, inhibitors and inducers of P-gp have been extensively carried out due to the immense capability of P-gp in altering the substrate bioavailability. Lown *et al.* (1997a) reported the potential of P-gp as a rate-limiting first-pass elimination mechanism of cyclosporin in 19 patients. Common azole antifungals were reported by Wang *et al.* (2002) to inhibit functions of P-gp. However, further investigation revealed that only itraconazole and ketoconazole were shown to inhibit P-gp functions *in vitro* at 50% inhibitory concentrations (IC₅₀) of approximately 2 and 6 µM, respectively; while fluconazole had no effect on functions of P-gp. In another report by Rebbeor and Senior (1998), using two *in vitro* ATPase assays, cardiovascular drugs, namely verapamil, diltiazem, nifedipine and quinidine were found to stimulate the ATPase activity of P-gp. Verapamil and quinidine stimulated maximum ATPase activity at 10 µM, while nifedipine and diltiazem at 30 µM and 100 µM, respectively. All these four drugs exhibited a biphasic effect on P-gp. Above the concentrations at which maximum ATPase activity was stimulated, there was a corresponding decrease in activity. Likewise, tamoxifen (antiestrogen), naloxone (morphine antagonist) and progesterone (natural steroid) have been shown to stimulate ATPase activity in the *in vitro* assays.

Due to the ability of P-gp to mediate the oral bioavailability of a wide range of structurally and functionally diverse drugs, a lot of literature on drug-drug interactions as a result of inhibition or induction of P-gp has been reported. Digoxin, which is poorly metabolised by human CYP3A but is a known substrate of P-gp has been used in many studies evaluating the inhibitory or induction effect of other drugs on P-gp (Salphati and Benet, 1998; Westphal *et al.*, 2000; Kato *et al.*, 2001; Drescher *et al.*, 2003; Cornaire *et al.*, 2004). The action on P-gp by the other drugs will consequently modulate the bioavailability as well as the pharmacokinetics of digoxin. Ketoconazole was able to inhibit P-gp, thereby elevating the plasma digoxin concentration, and hence AUC by 4 to 5 folds after oral and intravenous administration of digoxin (Salphati and Benet, 1998). Westphal *et al.* (2000) reported significant increase in AUC of digoxin following oral co-administration with 100 mg talinolol. However, the interaction between digoxin and talinolol was suggested to be attributed to the competition of the two substrates for intestinal P-gp rather than inhibition of P-gp by talinolol. In addition, rifampicin co-administration with digoxin has resulted in a significant reduction in digoxin AUC, with rifampicin being an inducer of P-gp (Drescher *et al.*, 2003).

Apart from drugs, excipients and surfactants used in pharmaceutical formulation have been shown to enhance absorption of P-gp substrate drugs. For example, Martin-Facklam *et al.* (2002) demonstrated the dose-dependence of Cremophor EL in enhancing the oral bioavailability of saquinavir. Cornaire *et al.* (2004) further tested the abilities of Labrasol, Imwitor 742, Acconon E, Softigen 767, Cremophor EL, Miglyol, Solutol HS 15, sucrose monolaurate, Polysorbate 20, TPGS and Polysorbate 80 to alter the transport of digoxin and celiprolol through the inverted gut sac as well as their pharmacokinetic profiles in Sprague-Dawley rats. Although transports of digoxin and celiprolol were most effective with Labrasol and Softigen 767 respectively, *in vivo* studies showed no significant increase in the overall AUCs of digoxin and celiprolol in spite of other changes in the pharmacokinetic profiles.

Besides being saturable, P-gp transport can be modulated by the presence of inhibitors and inducers. Inhibition of P-gp could potentially result from either competition for drug binding sites, or inhibition of ATP hydrolysis (P-gp is an energy dependent efflux pump) (Tamai and Safa, 1991; Ramachandra *et al.*, 1998; Lin, 2003). On the other hand, induction of P-gp is associated with the involvement of steroid xenobiotic receptor (SXR), a member of the nuclear hormone receptor superfamily as reviewed by Mizuno *et al.* (2003). In addition, canalicular P-gp can be induced by enhancing the intracellular trafficking through redistribution between membrane P-gp and intrahepatic pools (Synold *et al.*, 2001). Furthermore, in a review by Lin (2003), it was shown that induction of P-gp is dose- and tissue- dependent.

There are an increasing number of studies reporting the use of P-gp inhibitors in improving oral drug bioavailability (only applicable for drugs which exhibited poor bioavailability due to extensive efflux transport by P-gp because not all of the drugs known to be substrates of P-gp exhibit poor oral bioavailability) (Lin, 2003), as it has been postulated that inhibition of P-gp might improve intestinal absorption and tissue distribution while reducing the substrate metabolism and elimination. Nevertheless, a potent yet safe and effective P-gp inhibitor has yet to be identified for co-administration with poorly bioavailable P-gp substrate drugs for enhanced absorption. It is anticipated that proof-of-concept studies involving patients with concomitant administration of P-gp inhibitor could be realised to offer a novel strategy for improving oral drug absorption.

1.4.2 Intestinal phase I metabolising enzyme, CYP3A

To date, the human genome encodes 57 cytochrome P450 (CYP) proteins which are the predominant phase I drug metabolising enzymes (Shimada *et al.*, 1994). They represent a large superfamily of members with porphyrin haem complex as the catalytic moiety flanked by different protein structures which impart selectivity against various substrates (Gonzalez, 1989). Up till now, the major drug metabolising isoenzymes of

human CYP family identified are CYP1A2, 2A6, 2C8/9/10/19, 2D6, 2E1 and 3A4; CYP3A is the primary CYP subfamily among these isoforms (Shimada *et al.*, 1994; Nelson *et al.*, 1996; Smith *et al.*, 1998).

Besides being localised in the liver where the major first-pass metabolism occurs, CYP enzymes are also found abundant in the small intestine, colon, pancreas and kidney (Kolars *et al.*, 1992; Shimada *et al.*, 1994). CYP enzymes are expressed in the villus tip of enterocytes of the GIT, in which CYP3A is the most abundant in human GIT, accounting for more than 70% of small intestine CYP (Watkins *et al.*, 1987). However, expression of CYP3A is highly variable among individuals, with 30 folds variation reported for the small intestine (Wacher *et al.*, 1998). Besides that, expression of CYP3A is not homogenous in the small intestine, exhibiting a significant gradient, being highest in the duodenum and lower towards distal ileum (de Waziers *et al.*, 1990; Thummel *et al.*, 1997). It is believed that hepatic and intestine CYP3A are of the same isoforms as the cDNAs of CYP3A in both locations are identical (Lown *et al.*, 1998) but not coordinately regulated (von Richter *et al.*, 2004). Therefore, it is evident that intestinal first-pass metabolism is also regarded as a major determinant of systemic bioavailability of orally administered drugs (Wacher *et al.*, 1998).

Similar to P-gp, CYP3A exhibited broad substrate specificity. As mentioned earlier in section 1.4, as high as 50% of orally administered drugs may be substrates of this enzyme. Hence, the importance of CYP3A was accounted with respect to their action, duration and disposition on drugs and the metabolites (Gibson *et al.*, 2002). Like P-gp, besides being saturable, CYP3A can also be inhibited or induced by a number of structurally unrelated compounds.

When rifampicin (a CYP3A inducer) was co-administered with cyclosporin (a known substrate of CYP3A), Hebert *et al.* (1992) reported that cyclosporin clearance was

When rifampicin (a CYP3A inducer) was co-administered with cyclosporin (a known substrate of CYP3A), Hebert *et al.* (1992) reported that cyclosporin clearance was increased while half life, bioavailability and C_{max} were decreased. In contrast, when co-administered with an inhibitor of CYP3A, ketoconazole, the oral bioavailability of cyclosporin obtained was 56% compared to 22% without ketoconazole co-administration (Gomez *et al.*, 1995). Apart from being a substrate, cyclosporin also exhibit inhibitory effect on CYP3A when it was reported to decrease the extraction ratio of midazolam and felodipine to 60% and 46% respectively in CYP3A-transfected Caco-2 cells (Benet *et al.*, 2004). In another report by Li *et al.* (2002), ketoconazole was also found to decrease the metabolism of indinavir by CYP3A.

The inhibition and induction of CYP3A by a wide range of therapeutic agents have led to many drug-drug interactions being reported. Apart from drugs, food or herb constituents have also been shown to inhibit or induce CYP3A, resulting in food- or herb-drug interactions. Further discussion on the food- and herb-drug interactions will be elaborated in section 1.5.

1.4.3 Interactions between gastrointestinal P-gp and CYP3A

Due to overlapping substrate specificity and tissue distribution, together with co-inducibility of both P-gp and CYP3A, these two proteins act synergistically in altering the oral bioavailability of their substrate drugs (Benet *et al.*, 1999; Yumoto *et al.*, 1999; Cummins *et al.*, 2002; Mizuno *et al.*, 2003; Benet *et al.*, 2004). Besides being localised closely in the enterocytes, both genes encoding P-gp and CYP3A are also found on the same chromosome in close proximity, i.e. 7q21.1 for MDR1 (P-gp) while 7q22.1 for CYP3A (Watkins, 1997; Bertz and Granneman, 1997; Ishikawa *et al.*, 2004).

Several proposed synergistic mechanisms of P-gp and CYP3A in limiting the oral drug bioavailability are briefly summarised as follows (Watkins, 1997):

- i) P-gp, located at the apical brush border membrane may control the total drug transport across the epithelial cells by extruding the drug back into the gastrointestinal lumen while ensuring CYP3A is not being saturated.
- ii) P-gp may prolong the residence time of drugs in the enterocytes through the repeated process of extrusion and reabsorption, hence increasing the extent of exposure to intestinal metabolisms by CYP3A.
- iii) In addition, P-gp may also selectively extrude metabolites from within the enterocytes where the metabolites are also substrate of CYP3A.

In vitro studies using L-MDR1, LLC-PK1 and Caco-2 cells as well as *in vivo* studies using *mdr1a* deficient mice were carried out by Kim *et al.* (1999) to evaluate the potential of some established CYP3A substrates as inhibitors and substrates of P-gp. However, it was discovered that not all substrates of CYP3A were substrates of P-gp. Nifedipine and midazolam were only substrates of CYP3A whereas terfenadine, erythromycin and lovastatin were shown to be substrates of both CYP3A and P-gp. Kim *et al.* (1999) also revealed that transport of digoxin in Caco-2 cell was increased in the presence of PSC-833, quinidine, verapamil, ketoconazole and terfenadine, suggesting that these substrates of CYP3A might be inhibitors of P-gp. Following that, Katoh *et al.* (2001) correlated the inhibitory effect of CYP3A substrates and their metabolites on P-gp-mediated transport. They found that the transport of [³H]digoxin in the LLC-GA5-COL150 cells was strongly inhibited by amiodarone, desethylamiodarone (metabolite of amiodarone), azelastine and demethylazelastine (metabolite of azelastine) at IC₅₀ values of 45.6, 25.2, 30.0 and 41.8 μM, respectively.

Tacrolimus is a potent immunosuppressive macrolide lactone showing poor oral bioavailability, which may be attributed to incomplete absorption, nutrient intake, concomitant medications, metabolism by CYP3A in liver and gut and/or alteration of P-gp-mediated drug efflux. Other than co-administration of digoxin, 2-fold increase in

bioavailability of tacrolimus was also reported by Floren *et al.* (1997) when ketoconazole was co-administered. Besides that, the efflux of indinavir (peptidomimetic HIV protease inhibitor) a known substrate of P-gp and CYP3A, in the Ussing Chamber system was significantly altered by verapamil and cyclosporin at a rate of 37 and 38%, respectively (Li *et al.*, 2002).

Cummins *et al.* (2002) reported that inhibition of both P-gp and CYP3A by cyclosporin resulted in a decreased extraction ratio of midazolam to 60% and felodipine to 46% (both are substrates of only CYP3A but not P-gp). For bisubstrates of P-gp and CYP3A, i.e. K77 and sirolimus, greater decrease in extraction ratio to 74 and 83%, respectively was achieved, revealing the synergistic effect of P-gp and CYP3A. These findings suggested that P-gp can increase the exposure of drugs to intestinal CYP3A by repeated efflux and reabsorption of drugs in the GIT. In another study using the rat single-pass intestinal perfusion model, Cummins *et al.* (2003) again substantiated the role of P-gp in modulating the extent of intestinal metabolism by regulating drug access to the enzyme.

Since there are many overlapping substrates/inhibitors/inducers between P-gp and CYP3A, simultaneous administration of their inhibitors or inducers might result in drug-drug interactions, leading to increased or decreased drug bioavailability. Besides being critical to older patients who usually receive multidrug therapy, such interactions are also given attention especially when drugs with narrow therapeutic indices are used. Induction of P-gp and CYP3A might lead to ineffective oral drug therapy due to high efflux as well as metabolism along the GIT. On the contrary, inhibition of P-gp and CYP3A might also be hazardous especially for drugs with narrow therapeutic indices whereby drugs may accumulate in the systemic circulation, exceeding the therapeutic window, hence causing toxicity.