

**ACTIVE POWER FILTER WITH AUTOMATIC
CONTROL CIRCUIT FOR NEUTRAL CURRENT
HARMONIC MINIMIZATION TECHNIQUE**

MOHD IZHAR BIN A BAKAR

UNIVERSITI SAINS MALAYSIA

2007

**ACTIVE POWER FILTER WITH AUTOMATIC CONTROL CIRCUIT FOR
NEUTRAL CURRENT HARMONIC MINIMIZATION TECHNIQUE**

by

MOHD IZHAR BIN A BAKAR

**Thesis submitted in fulfilment of the requirements
for the degree of
Doctor of Philosophy**

June 2007

ACKNOWLEDGEMENTS

بِسْمِ اللَّهِ الرَّحْمَنِ الرَّحِيمِ

In the name of ALLAH, the most compassionate and the merciful.

I would like to express my sincere gratitude to my supervisor, Professor Dr. Ir. Che Mat Hadzer Mahmud, for his guidance, encouragement and continuing support throughout the course of this work. His extensive knowledge, advice and creative thinking have been an invaluable help to this research work.

I would also like to thank my co-supervisor, Dr. Ir. Syafrudin Masri, for his invaluable discussions and time.

I am also grateful to the UniKL-BMI and MARA for giving me the chance undertakes this PhD study.

Recognition is extended to all staff at the School of Electrical and Electronic Engineering, Universiti Sains Malaysia for a pleasant working atmosphere. In particular, I wish to thank Mr. Ahmad Shaukhi Noor and Mr. Jamaludin Che Amat for their assistance and cooperation by providing components and equipment.

Finally, I would like to express my deepest gratitude to my family for their understanding and encouragement during the past years.

TABLE OF CONTENTS

	Page
ACKNOWLEDGEMENTS	ii
TABLE OF CONTENTS	iii
LIST OF TABLES	vii
LIST OF FIGURES	x
LIST OF PLATES	xvi
LIST OF SYMBOLS	xvii
LIST OF ABBREVIATION	xix
LIST OF PUBLICATIONS & SEMINARS	xxi
ABSTRAK	xxii
ABSTRACT	xxiv
CHAPTER 1 : INTRODUCTION	
1.1 Background	1
1.2 Objectives	6
1.3 Project Methodology	6
1.4 Scopes and Contributions	9
1.5 Thesis Outline	11
CHAPTER 2 : BACKGROUND AND LITERATURE REVIEW	
2.1 Introduction	13
2.2 Harmonic as a Power Quality Problem	14
2.3 Sources of Harmonics	15
2.3.1 Harmonics from Fast Switching of Power Electronic Devices	15
2.3.2 Harmonic from Conventional Sources	20
2.3.3 Harmonics from Modern Electronic Equipments	25
2.4 Effects of Harmonics	27
2.4.1 Additional Losses in Rotating Machinery, Transformers and Power Cables	28
2.4.2 Tripping of Circuit Breakers and Blowing Fuses	29
2.4.3 Capacitor Overloading and Failure	29
2.4.4 Signal Interference in Converter Equipment	30

2.4.5	Interference with Telecommunication Circuits and Ripple Control System	30
2.4.6	Increased Transmission Losses	31
2.4.7	Excessive Neutral Current in Neutral Wire	31
2.5	Limits of Harmonic	38
2.6	Harmonic Reduction Techniques	40
2.6.1	Passive Filters	40
2.6.2	Active Power Filters	42
2.7	Literature Review on Active Power Filter Applications	46
2.7.1	Injection of a Specific Harmonic Current	48
2.7.2	Active Power Filter Using PWM Inverters	49
2.7.3	Hybrid Filters	56
2.7.4	Unified Power Quality Conditioner (UPQC)	59
2.8	Summary	61

CHAPTER 3 : THE DESIGN AND IMPLEMENTATION CIRCUIT TECHNIQUE FOR ACTIVE POWER FILTER

3.1	Introduction	63
3.2	The Proposed and Development Modular of Active Power Filter to Reduce Neutral Current	64
3.3	The Principle of the Proposed Active Power Filter Modular	65
3.4	System Configuration	67
3.4.1	Three Phase Four Wire Electric Distribution Systems and Harmonic Generated	68
3.4.2	Current Sensors	69
3.4.3	Sine Wave Generator	70
3.4.4	Triangular Wave Oscillator	71
3.4.4.1	Dual Level Triangular Wave Oscillator	72
3.4.5	Automatic Control Circuit	74
3.4.6	Comparators and Gate Drivers	79
3.4.7	Power Circuit	83
3.4.8	Protection in Operating Systems	86
3.4.8.1	An Operational of Protection in Operating System Principle	88
3.4.9	Pulse Width Modulation Switching Strategy	91
3.4.9.1	Existing PWM Switching Strategy	91

3.4.9.2	Development of New PWM Switching Strategy	95
3.4.9.3	Comparisons Between Existing and New PWM Switching Strategy	98
3.4.10	Compensation Principle	99
3.4.11	Prototype for the Proposed Modular Active Power Filter to Minimize Harmonics and Reduce the Neutral Current of Three Phase Four Wire Systems	101
3.5	Simulation Results	101
3.6	Summary	109

CHAPTER 4 : EXPERIMENTAL RESULTS AND DISCUSSIONS

4.1	Introduction	111
4.2	The Experiment Results for the Effect of Linear and Nonlinear Load	112
4.2.1	The Effect of Linear Loads in Three Phase Four Wire Electric Power Distribution Systems	112
4.2.2	The Effect of Nonlinear Loads in Three Phase Four Wire Electric Power Distribution Systems	119
4.3	The Experiment Results for the Part by Part Circuits of the Proposed APF Modular	133
4.3.1	The Sine Wave Generator	133
4.3.2	The Dual Level Triangular Wave	136
4.3.3	The Operating Point of Automatic Control Circuit	137
4.3.4	The Comparator and Pulse Width Modulation Switching Strategy	139
4.3.5	The Power Circuit	144
4.4	The Experiment Results for the Active Power Filter Performance	147
4.4.1	The Active Power Filter ON Without Automatic Control Circuit Performance	148
4.4.2	The Active Power Filter ON With Automatic Control Circuit Performance	150
4.4.3	Effect of Active Power Filter on Power Line Distributions System	153
4.5	Summary	158

CHAPTER 5 : CONCLUSIONS AND FUTURE WORK

5.1	Conclusions	159
5.2	Suggestions and Future Work	160

BIBLIOGRAPHY	161
---------------------	-----

APPENDICES

Appendix A	The Measurement Results for Various Nonlinear Load Devices	174
Appendix B	Full and Half Bridge Active Power Filter	176
	B.1 Full Bridge Active Power Filter	176
	B.2 Half Bridge Active Power Filter	179
Appendix C	Triangular Wave Oscillator	182
Appendix D	The Power Losses in the Switching Device	184
	D.1 ON-state (conduction) losses	184
	D.2 Switching losses	184
Appendix E	The Measurement Results for Neutral and Harmonic Current Reduction	188
	E.1 Results for I_N 3.528 Amp. rms Reduce to I_N 1.114 Amp. rms	188
	E.2 Results for I_N 4.072 Amp. rms Reduce to I_N 1.282 Amp. rms	190
	E.3 Results for I_N 6.478 Amp. rms Reduce to I_N 2.065 Amp. rms	192
	E.4 Results for I_N 7.276 Amp. rms Reduce to I_N 2.308 Amp. rms	195
Appendix F	The Measurement Results for the Effect of Active Power Filter on Power Line Distributions System	197
	F.1 The Effect of APF on Power Line Distribution System at I_N 3.528 Amp. rms Reduce to I_N 1.114 Amp. rms	197
	F.2 The Effect of APF on Power Line Distribution System at I_N 4.072 Amp. rms Reduce to I_N 1.282 Amp. rms	200

LIST OF TABLES

	Page	
Table 2.1	Types and functions of converter	20
Table 2.2	Harmonics phase sequences for three phase power system	22
Table 2.3	Harmonic current distortion limit in Percentage (%)	40
Table 2.4	Comparison between passive and APF filter	45
Table 2.5	Active power filter techniques	46
Table 2.6	A combined series and shunt active power filter for unified power quality conditioner	61
Table 3.1	The comparisons between existing and new PWM switching strategy	98
Table 3.2	The simulation result for the stand alone inverter performance	106
Table 3.3	The stand-alone inverter performance results for current waveforms output and harmonic current spectrums at various loads	106
Table 3.4	The simulation results for neutral current reduction without automatic control circuit with star delta three phase transformer connections	107
Table 3.5	The harmonic components reduction by using APF without automatic control circuit via simulation	109
Table 4.1	The measurement results for current, voltage, THDv(%), THDi(%) and power drawn by resistor for balanced system	113
Table 4.2	The harmonic currents at each line drawn by resistor for balanced system	113
Table 4.3	The measurement results for current, voltage, THDv(%), THDi(%) and power drawn by resistor for unbalanced system	116
Table 4.4	The harmonic currents at each line drawn by resistor for unbalanced system	116
Table 4.5	The measurement results for current, voltage, THDv(%), THDi(%) and power drawn by resistor series with inductor as nonlinear loads of balanced system	119
Table 4.6	The harmonic currents at each line drawn by resistor series with inductor as nonlinear loads for balanced system	119
Table 4.7	The measurement results for current, voltage, THDv(%), THDi(%) and power drawn by resistor series with inductor as nonlinear loads of unbalanced system	123

Table 4.8	The harmonic currents at each line drawn by resistor series with inductor as nonlinear loads for unbalanced system	123
Table 4.9	The measurement results for current, voltage, THDv(%), THDi(%) and power drawn by resistor parallel with capacitor as nonlinear loads of balanced system	126
Table 4.10	The harmonic currents at each line drawn by resistor parallel with capacitor as nonlinear loads for balanced system	126
Table 4.11	The measurement results for current, voltage, THDv(%), THDi(%) and power drawn by resistor parallel with capacitor as nonlinear loads of unbalanced system	129
Table 4.12	The harmonic currents at each line drawn by resistor parallel with capacitor as nonlinear loads for unbalanced system	129
Table 4.13	The comparisons between experiment and simulation results for the frequency response of 50 Hz Notch Filter	134
Table 4.14	The comparisons results between experimental and simulation of dual level triangular wave	137
Table 4.15	The experimental results of voltage and resistance between LED and Photoresistor	138
Table 4.16	The experimental result for the stand-alone inverter performance	144
Table 4.17	The experimental results for neutral current reduction without automatic control circuit with star delta three phase transformer connections	148
Table 4.18	The harmonic components reduction by using APF without automatic control circuit via experiment	150
Table 4.19	The experimental results for neutral current reduction with automatic control circuit with star delta three phase transformer connections	150
Table 4.20	The harmonic components reduction by using APF with automatic control circuit via experiment	152
Table 4.21	The effect of APF on power line distribution system at I_N 2.511 Amp. rms	154
Table 4.22	The effect of APF on power line distribution system at I_N 3.528 Amp. rms	154
Table 4.23	The effect of APF on power line distribution system at I_N 4.072 Amp. rms	154
Table A1	Measuring results for nonlinear devices	174

Table E1	The harmonic components reduction by using APF with automatic control circuit via experiment	189
Table E2	The results for harmonic components reduction by using active power filter with automatic control circuit via experiment	191
Table E3	The harmonic components reduction by using active power filter with automatic control circuit via experiment	194
Table E4	The harmonic components reduction by using active power filter with automatic control circuit via experiment	196

LIST OF FIGURES

		Page
Figure 1.1	Harmonic distortions at PCC	2
Figure 1.2	Flowchart for Project Methodology	8
Figure 2.1	The Sources of Harmonics In Power Distribution System	16
Figure 2.2	Uncontrolled Rectifiers (a) Single Phase (b) Three Phase	18
Figure 2.3	Waveforms in Iron Cored Transformer (a) Applied voltage (b) B-H Curve (Hysteresis loop) (c) Current through an iron cored transformer	24
Figure 2.4	Block Diagram of a Modern Induction Furnace	25
Figure 2.5	General Control Scheme of a Static VAR Compensator	26
Figure 2.6	Basic Configurations for Typical Shunt APF	43
Figure 2.7	Basic Configurations for Typical Series APF	43
Figure 2.8	Block Diagram for Control Circuit of Shunt APF	50
Figure 2.9	Basic Circuit of APF	50
Figure 2.10	A Single Phase APF	52
Figure 2.11	The Block Diagram of APF	53
Figure 2.12	Three Phase Four Wire APF (a) Three Leg Inverter (Split Capacitor) (b) Four Leg Inverter (Common Capacitor)	56
Figure 2.13	Combined Circuit Between Series APF and Shunt Passive Filter	57
Figure 2.14	The Basic Circuit for APF Series with Passive Filter	58
Figure 2.15	Series-Shunt APF in a Three Phase Power System	59
Figure 2.16	Functional Block Diagram of the UPQC Controller	60
Figure 3.1	The Basic Block Diagram of the Filtering Technique	65
Figure 3.2	Block Diagram for the Proposed APF Modular	67
Figure 3.3	Three Phase Four Wire Electric Distribution System	68
Figure 3.4	The Combination Circuit Diagram for Current Sensor (CT1), Notch Filter and Controller-1	70
Figure 3.5	The Dual Level of Triangular Wave Circuit	72
Figure 3.6	The New of Dual Level for Triangular Wave Circuit	74
Figure 3.7	The Automatic Control Circuits for Output-Following Signal (a) The Circuit for Current Sensor, CT2, AC-DC Converters With Controller-2 (b) The Circuit for Triangular Oscillator, Photoresistor and LED	75

Figure 3.8	The Integrations Circuit for Triangular Oscillator, Automatic Circuit and Dual Level Triangular Wave	78
Figure 3.9	The Sinusoidal Pulse Width Modulation	79
Figure 3.10	The Circuit for Comparator and Driver	80
Figure 3.11	The Power Circuit of Half Bridge for APF	84
Figure 3.12	The Circuit Diagram for Protection in Operating System	87
Figure 3.13	The Circuit diagram for Existing PWM Switching Strategy (a) Single Pulse Width Modulation (b) Sinusoidal Pulse Width Modulation	91
Figure 3.14	The Generated Gating Signal at Three Cycles of Voltage Reference	93
Figure 3.15	The dead time control in SPWM modulation	94
Figure 3.16	A New PWM Switching Strategy (a) Single Voltage Reference Compared With Dual Level Triangular Wave Modulation (b) Upper Comparator Output - Upper SPWM Modulation (c) Lower Comparator Output-Lower SPWM Modulation (d) Gate Signal for Upper Switch-S1 (e) Gate Signal for Lower Switch-S2	95
Figure 3.17	The Dead Time and Point Centre of Half Cycle Voltage Reference	98
Figure 3.18	The Illustrations of Harmonic Compensation	100
Figure 3.19	Sine Wave Generator (a) Frequency Response of 50Hz Notch Filter (b) Neutral Current Waveform at Point 1 (c) Desired Neutral Current Waveform at Point 2	102
Figure 3.20	Dual Level Triangular Wave for Upper and Lower Site	103
Figure 3.21	Waveforms Results for Circuit in Figure 3.10 (a) Current Distorted Waveform via Upper Triangular Waveform at Input OP14 (b) SPWM at Point 3 (c) SPWM at Point 5 (d) Current Distorted Waveform via Lower Triangular Waveform at Input OP15 (e) SPWM at Point 4 (f) SPWM at Point 6 (g) Combine Gating Signal at Point 7 and 8 (h) The Dead Time between Upper and Lower Switching is 0.2 ms	105
Figure 3.22	The Comparisons Between Before and After Filtered for I_N 2.357Amp.rms (a) Neutral Current Waveforms (b) Harmonic Current Spectrum	108

Figure 4.1	Schematic Diagrams for Measurements of Three Phase Four Wire Electric Power Distribution	112
Figure 4.2	The Phase Voltage Waveforms and Harmonic Voltage Spectrum	114
Figure 4.3	The Line Current Waveforms and Harmonic Current Spectrums (a) Phase R (b) Phase Y (c) Phase B (d) Phase N	115
Figure 4.4	The Phase Voltage Waveforms and Harmonic Voltage Spectrum	117
Figure 4.5	The Line Current Waveforms and Harmonic Current Spectrums (a) Phase R (b) Phase Y (c) Phase B (d) Phase N	118
Figure 4.6	The Phase Voltage Waveforms and Harmonic Voltage Spectrum	120
Figure 4.7	The Line Current Waveforms and Harmonic Current Spectrums (a) Phase R (b) Phase Y (c) Phase B (d) Phase N	121
Figure 4.8	The Phase Voltage Waveforms and Harmonic Voltage Spectrum	124
Figure 4.9	The Line Current Waveforms and Harmonic Current Spectrums (a) Phase R (b) Phase Y (c) Phase B (d) Phase N	125
Figure 4.10	The Phase Voltage Waveforms and Harmonic Voltage Spectrum	127
Figure 4.11	The Line Current Waveforms and Harmonic Current Spectrums (a) Phase R (b) Phase Y (c) Phase B (d) Phase N	128
Figure 4.12	The Phase Voltage Waveforms and Harmonic Voltage Spectrum	130
Figure 4.13	The Line Current Waveforms and Harmonic Current Spectrums (a) Phase R (b) Phase Y (c) Phase B (d) Phase N	131
Figure 4.14	The Experiment Results for the Frequency Response of 50.0Hz Notch Filter	135
Figure 4.15	Signal Sine Wave Generator (a) Point 1 is the Sine Wave at Neutral Line (b) Point 2 is the Desired Voltage Waveform	136
Figure 4.16	The Dual Level Triangular Wave by Experimental Work	136
Figure 4.17	The Graph of the Operating Point for Automatic Control Circuit	138
Figure 4.18	The SPWM Signal and Dead Time Based On Comparators IC LM741	139
Figure 4.19	The SPWM Signal and Dead Time Based on IC Comparators (a) IC LM393 (b) IC LM393 with zooming to 80% of diagram	141

Figure 4.20	Waveforms Results for Figure 3.10 in Chapter 3 (a) Sinusoidal via Upper Triangular Waveform at OP14 (b) SPWM at Point 3 (c) SPWM at Point 5 (d) Sinusoidal via Lower Triangular Waveform at OP15 (e) SPWM at Point 4 (f) SPWM at Point 6 (g) Combine Gating Signal at Point 7 and 8	143
Figure 4.21	The Comparisons Results for Power Circuit Performance Between Experimental and Simulation for (a) Voltage Output (b) Current Output (c) Power Output (d) THDv (e) THDi	145
Figure 4.22	Stand-Alone Inverter Performance Results for Voltage Waveforms Output at Various Loads (a) 1.9Ω (b) 2.4Ω (c) 5.0Ω (d) 10.0Ω	146
Figure 4.23	The Stand-Alone Inverter Performance Results for Current Waveform Output and Harmonic Current Spectrum at Various Loads (a)1.9Ω (b) 2.4Ω (c) 5.0Ω (d) 10.0Ω	147
Figure 4.24	The Correlation Results for Neutral Current Reduction by Using APF Without Automatic Control Circuit Between Experimental and Simulation	148
Figure 4.25	The Comparisons Neutral Current Waveforms Results Between Before and After Filtered for I_N 2.494 Amp.rms	149
Figure 4.26	The Comparisons Harmonic Current Spectrum Results Between Before and After Filtered for I_N 2.494 Amp.rms	149
Figure 4.27	Waveforms and Harmonic Current Spectrum Before Filter for I_N 2.511Amp. rms (a) Neutral Current Waveforms (b) Harmonic Current Spectrum	151
Figure 4.28	Waveforms and Harmonic Current Spectrum After Filtered for I_N 0.788 Amp. rms (a) Neutral Current Waveforms (b) Harmonic Current Spectrum	152
Figure 4.29	The Comparisons Harmonic Current Spectrum Between Before and After Filtered for I_N 2.511Amp. rms	153
Figure 4.30	The Line Current Waveforms and Harmonic Current Spectrums at Power Line Distribution System Before APF Filter at I_N 2.511 Amp. rms (a) Phase R (b) Phase Y (c) Phase B	155

Figure 4.31	The Line Current Waveforms and Harmonic Current Spectrums at Power Line Distribution System After APF Filter at I_N 0.788 Amp. rms (a) Phase R (b) Phase Y (c) Phase B	156
Figure 4.32	The Comparisons Harmonic Current Spectrum Between Before and After Filtered at Power Line Distribution System for I_N 2.511 Amp. rms (a) Phase R (b) Phase Y (c) Phase B	157
Figure B1	Full Bridge Active Power Filter	176
Figure B2	Half Bridge Active Power Filter	179
Figure C1	Circuit Diagram for Triangular Oscillator	182
Figure C2	Square and Triangular Waveforms	183
Figure D1	Equivalent Circuit for Inductive Switching Circuit	184
Figure D2	Instantaneous Switch Power Loss	185
Figure E1	Current Waveforms and Harmonic Current Spectrum Before Filter I_N 3.528 Amp. rms (a) Neutral Current Waveforms (b) Neutral Harmonic Current Spectrum	188
Figure E2	Current Waveforms and Harmonic Current Spectrum After Filtered I_N 1.114 Amp. rms (a) Neutral Current Waveforms (b) Neutral Harmonic Current Spectrum	189
Figure E3	The Comparisons Harmonic Current Spectrum Between Before Filter I_N 3.528 Amp. rms and After Filtered I_N 1.114 Amp.rms for Neutral Current Reduction	190
Figure E4	Current Waveforms and Harmonic Current Spectrum Before Filter I_N 4.072 Amp. rms (a) Neutral Current Waveforms (b) Neutral Harmonic Current Spectrum	190
Figure E5	Current Waveforms and Harmonic Current Spectrum After Filtered I_N 1.282 Amp. rms (a) Neutral Current Waveforms (b) Neutral Harmonic Current Spectrum	191
Figure E6	The Comparisons Harmonic Current Spectrum Between Before Filter I_N 4.072 Amp. rms and After Filtered I_N 1.282 Amp.rms for Neutral Current Reduction	192
Figure E7	Current Waveforms and Harmonic Current Spectrum Before Filter I_N 6.478 Amp. rms (a) Neutral Current Waveforms (b) Neutral Harmonic Current Spectrum	193

Figure E8	Current Waveforms and Harmonic Current Spectrum After Filtered I_N 2.065 Amp. rms (a) Neutral Current Waveforms (b) Neutral Harmonic Current Spectrum	193
Figure E9	The Comparisons Harmonic Current Spectrum Between Before Filter I_N 6.478 Amp. rms and After Filtered I_N 2.065 Amp.rms for Neutral Current Reduction	194
Figure E10	Waveforms and Harmonic Current Spectrum Before Filter I_N 7.276 Amp. rms (a) Neutral Current Waveforms (b) Neutral Harmonic Current Spectrum	195
Figure E11	Current Waveforms and Harmonic Current Spectrum After Filtered I_N 2.308 Amp. rms (a) Neutral Current Waveforms (b) Neutral Harmonic Current Spectrum	196
Figure E12	The Comparisons Harmonic Current Spectrum Between Before Filter I_N 7.276 Amp. rms and After Filtered I_N 2.308 Amp.rms for Neutral Current Reduction	196
Figure F1	The Line Current Waveforms and Harmonic Current Spectrums at Power Distribution System Before APF Filter (a) Phase R (b) Phase Y (c) Phase B	197
Figure F2	The Line Current Waveforms and Harmonic Current Spectrums at Power Distribution System After APF Filtered (a) Phase R (b) Phase Y (c) Phase B	198
Figure F3	The Comparisons Harmonic Current Spectrum Between Before and After Filtered at Power Line Distribution System at I_N 3.528 Amp. rms (a) Phase R (b) Phase Y (c) Phase B	199
Figure F4	The Line Current Waveforms and Harmonic Current Spectrums at Power Distribution System Before APF Filter (a) Phase R (b) Phase Y (c) Phase B	200
Figure F5	The Line Current Waveforms and Harmonic Current Spectrums at Power Distribution System After APF Filtered (a) Phase R (b) Phase Y (c) Phase B	201
Figure F6	The Comparisons Harmonic Current Spectrum Between Before and After Filtered at Power Line Distribution System at I_N 4.072 Amp. rms (a) Phase R (b) Phase Y (c) Phase B	202

LIST OF PLATES

		Page
Plate 3.1	Three Phase Four Wire Electric Distribution System (a) Tungsten Lamps (b) Single Phase Load Wiring at Each Phase (c) Phase Line	69
Plate 3.2	The Combination Circuits in same Printed Circuit Board (a) Sine Wave Generator (b) Dual Level Triangular Wave Oscillator (c) Automatic Control Circuit	78
Plate 3.3	The Comparator and Driver Circuit in same Printed Circuit Board (a) SPWM Modulation (b) Gating Signal for Lower and Upper of Power Switcher (c) Snubber Circuit	83
Plate 3.4	The Power Circuit for Active Power Filter (a) Power Switcher (b) Heat Sink (c) Clamp Capacitor	84
Plate 3.5	The hardware for safety precaution (a) Controller Circuit and Driver for Safety Precaution (b) Magnetic Contactor for Neutral Line (c) Magnetic Contactor for DC Supply (d) Magnetic Contactor for Three Phase Line	88
Plate 3.6	The Prototype for the Proposed Modular Active Power Filter	101

LIST OF SYMBOLS

i_R	Current for Phase R
i_Y	Current for Phase Y
i_B	Current for Phase B
I_{1m}	Amplitude of Fundamental Current
I_{nm}	Amplitude of n^{th} Harmonic Current
n	Harmonic Order
ϕ_1	Phase Angel of Fundamental Current
ϕ_n	Phase Angel of n^{th} Harmonic
f	Frequency of Fundamental Current
ω	Angular Speed
i_N	Neutral Current
I_{SC}	Short Circuit Current
I_L	Load Current
I_{hc}	Harmonic Current
I_s	Source Current
V_{inj}	Harmonic Voltage Injection
V_L	Load Voltage
C_{bstrap}	Bootstrap Capacitor
Q_{Gate}	Total Gate Charge
V_{Gate}	Gate Voltage
t_d	Dead Time
j	Phase a,b and c
$i_{j,1}$	Fundamental component of the load current
$i_{j,h}$	The distorted current for phase j
$i_{j,h}^+$	Positive Sequence Harmonic
$i_{j,h}^-$	Negative Sequence Harmonic
$i_{j,h}^0$	Zero Sequence Harmonic

$i_{af,j}$	Active Power Filter Current
$i_{s,j}$	Supply Current
V_{on}	Voltage Across Power Switcher during ON Period
I_{sw}	Current Through Power Switcher during ON Period
P_{cond}	Conduction Loss
t_r	Rise Time
t_f	Fall time
V_d	Voltage Across Power Switcher during OFF period
E_{ON}	Energy Loss during Power Switcher during ON
t_{ON}	Turn-ON time
t_{OFF}	Turn-OFF time
E_{OFF}	Energy Loss during Power Switcher during OFF
E_{SW}	Total Energy Loss by Power Switcher
f_{SW}	Switching Frequency
P_{SW}	Average Power Loss by Power Switcher

LIST OF ABBREVIATION

EPR	Electric Power Research
THD	Total Harmonic Distortion
PCC	Point Common Coupling
THDi	Total Harmonic Current Distortion
CBEMA	Computer and Business Equipment Manufacturer Association
AC	Alternative Current
IEEE	Institute of Electrical and Electronic Engineers
APF	Active Power Filter
DC	Direct Current
PWM	Pulse Width Modulation
IGBT	Insulated Gate Bipolar Transistor
MOSFET	Metal Oxide Field Effect Transistor
rms	Root Mean Square
MCB	Miniature Circuit Breaker
UPS	Uninterruptible Power Supplies
PC	Personal Computer
TV	Television
MVA	Megavolt Ampere
emf	Electromotive Force
B	Flux Density
H	Magnetic Field Intensity
VAR	Static Apparent Power
TCRs	Thyristor Controlled Reactors
TSCs	Thyristor Switched Capacitor
Pf	Power Factor
Q	Quality Factor
R	Red
Y	Yellow
B	Blue
N	Neutral
HF	Harmonic Distortion Factor
WS	Weighted Sum
R'	Resistance
L	Inductance

C	Capacitance
IL	Load Current
I _{hc}	Harmonic current
I _s	Source Current
V _{inj}	Harmonic Voltage Injection
V _L	Load Voltage
V _{PCC}	Point Common Coupling Voltage
CSI	Current Source Inverter
VSI	Voltage Source Inverter
GTO	Gate Turn OFF
ICM	Compensation Current
PQM	Power Quality Management
UPQC	Unified Power Quality Conditioner
SPWM	Sinusoidal Pulse Width Modulation
CT	Current Sensor
I _N	Neutral Current
TP	Test Point
EMI	Electromagnetic Interference
LED	Light Emitting Diode
DFB	Full Bridge Rectifier
TTL	Transistor-Transistor Logic
IC	Integrated Circuit
TR	Power Transistor
RY	Power Relay
CONT	Magnetic Contactor
NO	Normally Open
NC	Normally Closed
PESIM	Power Electronics Circuit Simulation
THD _v	Total Harmonic Voltage Distortion
L _f	Link Reactor

LIST OF PUBLICATIONS & SEMINARS

International Conference

1. Izhar, M., Hadzer, C.M. and Syafrudin, M. (2003). Preliminary of Closed Loop Harmonic Study Analysis in Under Load Variations for Power System. *IEEE Proceedings of the International Conference On Robotics, Vision, Information and Signal Processing*. 1. 675 – 682.
2. Izhar, M., Hadzer, C.M. and Syafrudin, M. (2003). Reduced Order Model of a Switched Capacitor Design. *IEEE Proceedings of the International Conference On Robotics, Vision, Information and Signal Processing*. 1. 683 – 689.
3. Izhar, M., Hadzer, C.M. and Syafrudin, M. (2003). An Analysis of the Harmonic Effect to Power Factor in the Power System. *IEEE Proceedings Engineering and Technology Conference*. 407 – 414.
4. Izhar, M., Hadzer, C.M. and Syafrudin, M. (2003). A Study of the Fundamental Principles to Power System Harmonics. *IEEE National Power Engineering Conference Proceedings*. 225 – 232.
5. Izhar, M., Hadzer, C.M. and Syafrudin M. (2003). An Investigation on Harmonic Level, Current & Voltage Distortion and Associated Power for Three Phase Four Wire Distribution System in a USM Electrical & Electronic Engineering Department Building. *IEEE National Power Engineering Conference Proceedings*. 371 – 378.
6. Izhar, M., Hadzer, C.M. and Syafrudin, M. (2004). Harmonics Reduction Performance of Passive and Active Power Filter in Distribution System. *Proceedings 6th Industrial Electronics Seminar, JICA-IEEE*, Oct. 42 – 46.
7. Izhar, M., Hadzer, C.M. and Syafrudin, M. (2004). An Analysis and Design of A Star Delta Transformer In Series With Active Power Filter for Current Harmonics Reduction. *IEEE National Power & Energy Conference*, Dec. 94 – 98.
8. Izhar, M., Hadzer, C.M. and Syafrudin, M. (2004). Performance for Passive and Active Power Filter in Reducing Harmonics in the Distribution System. *IEEE National Power & Energy Conference Proceedings*, Dec. 104 – 108.

TEKNIK PENURAS KUASA AKTIF DENGAN LITAR KAWAL AUTOMATIK UNTUK MEMINIMUMKAN HARMONIK ARUS NEUTRAL

ABSTRAK

Disertasi ini bertujuan untuk membangun penuras kuasa aktif yang cekap dan boleh dipercayai bagi meminimumkan lebih harmonik arus neutral dan juga masalah harmonik di dalam talian neutral untuk sistem tiga fasa empat dawai. Arus neutral ini pada umumnya mengandungi tertib harmonik ' triplen' seperti ke-3, ke-9, ke-15 dan lain-lain yang dijanakan oleh beban tidak lurus. Arus harmonik ke-3 adalah harmonik dominan. Untuk mengatasi masalah ini, disertasi ini mencadangkan skema penuras kuasa aktif bersama aplikasi pengubah bintang-delta bagi membatalkan harmonik arus neutral dalam talian neutral. Kajian ini mencadangkan penuras kuasa aktif terdiri daripada pensuis kuasa yang dimodulasikan berdasarkan teknik pensuisan baru dengan menggunakan aras duaan gelombang segitiga dan gelombang sinus tunggal. Dalam mempertingkatkan lagi pengurangan arus harmonik, litar baru kawal automatik untuk isyarat keluaran-mengekor adalah diperkenalkan. Ini untuk membolehkan pemodulatan lebar denyut yang dijanakan dengan penuras kuasa aktif adalah selaras dengan tidak ketetapan magnitud arus neutral. Kajian ini juga mencadangkan pendekatan baru untuk perlindungan dalam sistem operasi bagi membolehkan sistem dalam mod terbuka secara automatik disebabkan arus lampaun atau litar pintas. Prestasi keputusan keseluruhan menunjukkan bahawa pengurangan arus neutral dengan menggunakan penuras kuasa aktif dengan litar kawal automatik ialah 68.4%, berbanding kepada litar tanpa kawal automatik iaitu 61.9%. Peningkatan pengurangan arus neutral ialah 6.5%. Keputusan juga menunjukkan bahawa purata pengurangan arus harmonik untuk ke-3, ke-9 dan ke-15 masing-masing bertambah daripada 60.1% kepada 65.8%, 67.7% kepada 74.9% dan 71.1% kepada 75.9%. Kajian mengenai kesan dari penuras kuasa aktif ke atas sistem talian elektrik pengagihan kuasa juga dijalankan. Purata keputusan menunjukkan bahawa jumlah kandungan arus harmonik

berkurangan daripada 83.6% kepada 62.3%. Sementara itu, faktor kuasa bertambah daripada 0.54 kepada 0.76. Perihal sah keputusan ditunjukkan dengan simulasi dan ujikaji.

ACTIVE POWER FILTER WITH AUTOMATIC CONTROL CIRCUIT FOR NEUTRAL CURRENT HARMONIC MINIMIZATION TECHNIQUE

ABSTRACT

The aim of this thesis is to develop an efficient and reliable active power filter in order to minimize the excessive neutral current as well as harmonic problem in the neutral line for three phase four wire system. This neutral current generally consists of triplen harmonics order such as 3rd, 9th, 15th and etc., which are generated by nonlinear load. The dominant harmonic is 3rd harmonic current. In response to this problem, this thesis proposes an active power filter scheme along with star-delta transformer application to cancel neutral current harmonic in neutral line. The development of active power filter, consisting of power switcher, which is modulated based on new switching technique by using dual level triangular waveform and single sinusoidal, is proposed. In order to further improve the harmonic current reduction, the new automatic control circuit for output-following signal is introduced. This is to enable the pulse width modulation to be generated by active power filter that is synchronized with magnitude of neutral current inconsistency. The research also proposes a new approach for the protection in operating system that enables the system to be in turn-OFF mode automatically due to over current or short circuit. The overall performance results showed that the neutral current reduction by using active power filter with automatic control circuit was 68.4% as compared to without automatic control circuit, which was 61.9%. The improvement of neutral current reduction was 6.5%. The results also showed that the average of harmonic current reduction for 3rd, 9th, and 15th increased from 60.1% to 65.8%, 67.7% to 74.9%, and 71.1% to 75.9% respectively. A study on the effects of active power filter on the electrical power line distribution system was also carried out. The overall result showed that the Total Harmonic Current Distortion decreased from 83.6% to 62.3%. Meanwhile, the Power Factor increased from 0.54 to 0.76. The validity of results is demonstrated by simulation and experiment.

TEKNIK PENURAS KUASA AKTIF DENGAN LITAR KAWAL AUTOMATIK UNTUK MEMINIMUMKAN HARMONIK ARUS NEUTRAL

ABSTRAK

Disertasi ini bertujuan untuk membangun penuras kuasa aktif yang cekap dan boleh dipercayai bagi meminimumkan lebih harmonik arus neutral dan juga masalah harmonik di dalam talian neutral untuk sistem tiga fasa empat dawai. Arus neutral ini pada umumnya mengandungi tertib harmonik ' triplen' seperti ke-3, ke-9, ke-15 dan lain-lain yang dijanakan oleh beban tidak lurus. Arus harmonik ke-3 adalah harmonik dominan. Untuk mengatasi masalah ini, disertasi ini mencadangkan skema penuras kuasa aktif bersama aplikasi pengubah bintang-delta bagi membatalkan harmonik arus neutral dalam talian neutral. Kajian ini mencadangkan penuras kuasa aktif terdiri daripada pensuis kuasa yang dimodulasikan berdasarkan teknik pensuisan baru dengan menggunakan aras duaan gelombang segitiga dan gelombang sinus tunggal. Dalam mempertingkatkan lagi pengurangan arus harmonik, litar baru kawal automatik untuk isyarat keluaran-mengekor adalah diperkenalkan. Ini untuk membolehkan pemodulatan lebar denyut yang dijanakan dengan penuras kuasa aktif adalah selaras dengan tidak ketetapan magnitud arus neutral. Kajian ini juga mencadangkan pendekatan baru untuk perlindungan dalam sistem operasi bagi membolehkan sistem dalam mod terbuka secara automatik disebabkan arus lampaun atau litar pintas. Prestasi keputusan keseluruhan menunjukkan bahawa pengurangan arus neutral dengan menggunakan penuras kuasa aktif dengan litar kawal automatik ialah 68.4%, berbanding kepada litar tanpa kawal automatik iaitu 61.9%. Peningkatan pengurangan arus neutral ialah 6.5%. Keputusan juga menunjukkan bahawa purata pengurangan arus harmonik untuk ke-3, ke-9 dan ke-15 masing-masing bertambah daripada 60.1% kepada 65.8%, 67.7% kepada 74.9% dan 71.1% kepada 75.9%. Kajian mengenai kesan dari penuras kuasa aktif ke atas sistem talian elektrik pengagihan kuasa juga dijalankan. Purata keputusan menunjukkan bahawa jumlah kandungan arus harmonik

berkurangan daripada 83.6% kepada 62.3%. Sementara itu, faktor kuasa bertambah daripada 0.54 kepada 0.76. Perihal sah keputusan ditunjukkan dengan simulasi dan ujikaji.

ACTIVE POWER FILTER WITH AUTOMATIC CONTROL CIRCUIT FOR NEUTRAL CURRENT HARMONIC MINIMIZATION TECHNIQUE

ABSTRACT

The aim of this thesis is to develop an efficient and reliable active power filter in order to minimize the excessive neutral current as well as harmonic problem in the neutral line for three phase four wire system. This neutral current generally consists of triplen harmonics order such as 3rd, 9th, 15th and etc., which are generated by nonlinear load. The dominant harmonic is 3rd harmonic current. In response to this problem, this thesis proposes an active power filter scheme along with star-delta transformer application to cancel neutral current harmonic in neutral line. The development of active power filter, consisting of power switcher, which is modulated based on new switching technique by using dual level triangular waveform and single sinusoidal, is proposed. In order to further improve the harmonic current reduction, the new automatic control circuit for output-following signal is introduced. This is to enable the pulse width modulation to be generated by active power filter that is synchronized with magnitude of neutral current inconsistency. The research also proposes a new approach for the protection in operating system that enables the system to be in turn-OFF mode automatically due to over current or short circuit. The overall performance results showed that the neutral current reduction by using active power filter with automatic control circuit was 68.4% as compared to without automatic control circuit, which was 61.9%. The improvement of neutral current reduction was 6.5%. The results also showed that the average of harmonic current reduction for 3rd, 9th, and 15th increased from 60.1% to 65.8%, 67.7% to 74.9%, and 71.1% to 75.9% respectively. A study on the effects of active power filter on the electrical power line distribution system was also carried out. The overall result showed that the Total Harmonic Current Distortion decreased from 83.6% to 62.3%. Meanwhile, the Power Factor increased from 0.54 to 0.76. The validity of results is demonstrated by simulation and experiment.

CHAPTER 1 INTRODUCTION

1.1 Background

In a three phase four wire distribution systems have been widely employed to deliver electric power at low voltage levels. A typical low voltage of three phase four wire system in the Malaysian consists of a 415/240V in distributing electric energy to several office buildings and manufacturing plants. Therefore, the operating conditions have changed dramatically because of the rapid growth of advanced power conversion devices, electronics equipments, computers, office automation, air-conditioning systems, adjustable speed heating ventilation and etc. [Kevin, J.T. and Rich, P., 1997]. According to the Electric Power Research (EPR) in 1995, 35-40% of all electric power flows through electronic converters. This is expected to increase to 70% by the year 2000 [Roger, C.D., *et.al.*, 1996]. All these devices are namely as nonlinear loads and become sources of harmonics. Harmonics is considered as one of the most essential problems in electrical power systems.

Harmonics in power distribution system are current or voltage that are integer multiples of fundamental frequency. For example if the fundamental frequency 50Hz, then 3rd is 150Hz, 5th is 250Hz [Robert, D.H. and Patrick, J., 1994]. Ideally, voltage and current waveforms are perfect sinusoids. However, because of the increased popularity of electronic and non linear loads, these waveforms become distorted. This deviation from a perfect sine wave can be represented by harmonic components having a frequency that is an integral multiple of the fundamental frequency. Thus, a pure voltage or current sine wave has no distortion and no harmonics and a non sinusoidal wave has distortion and harmonics. In order to quantify the distortion, the term of Total Harmonics Distortion (THD) is used. The THD value is the effective

value of all the harmonics current added together compared with the value of the fundamental current [John, H.W., 2001].

The simple block diagram in Figure 1.1 illustrates the distortion problem due to harmonic at low voltage levels.

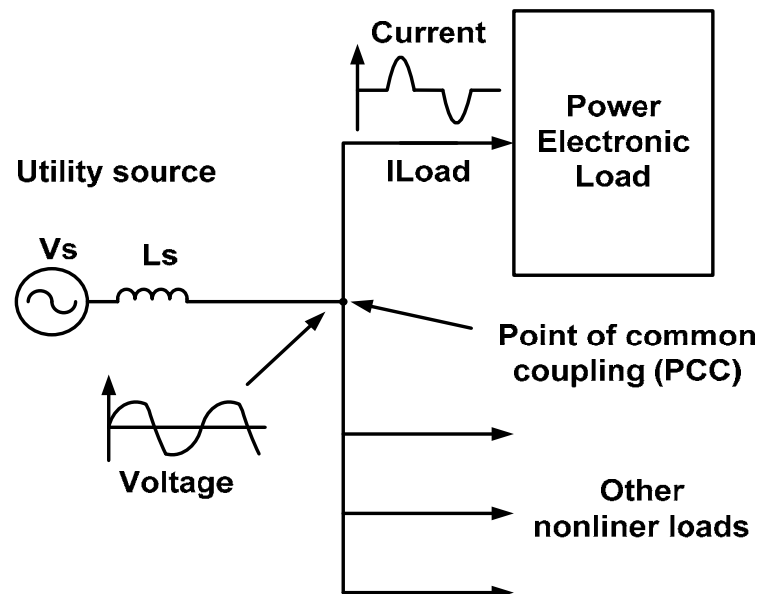

Figure 1.1: Harmonic distortions at PCC

The voltage waveform at the Point Common Coupling (PCC) is distorted due to harmonic current generated by the power electronic or nonlinear load. This result will effects on the line currents distortion is increased, malfunction of sensitive electronic equipment, increased losses and contributes to inefficient use of electric energy [Takeda, M., *et.al.*, 1987, Juan, C.M. and Samra, A.H., 1998].

In a three phase four wire distribution systems, under normal operating conditions with the loads are balanced, the current in the neutral current conductor is expected to be small, typically is not to exceed 20% of the normal load current in the phase [Choy, A.L., 1989]. However, the problem of excessive neutral current in three phase four wire systems is arised due to rapid growth of advanced nonlinear loads.

The neutral currents are basically zero sequence current harmonics, which is mostly, consists of triplen current harmonics. The zero sequence current harmonics, especially the 3rd and other odd triplens 9th, 15th, 21st, 27th and etc. will be accumulated in the neutral wire, thus results in overloading of the neutral conductor and the distribution transformer. The most dominant harmonic current is 3rd harmonic. Due to that, the neutral current magnitudes are higher than compared with phase currents. A survey results for 146 computers by Gruzis is indicated that 23% had neutral currents exceeding the phase currents and their Total Harmonic Current Distortion (THDi) is more than 100% [Gruzis, T.M., 1990]. Inductive ballast also inject considerable harmonics in neutral conductors, fire has been reported due to such overloading incident [Liew, A.C., 1989]. These results also founded by Computer and Business Equipment Manufacturer Association (CBEMA). CBEMA recently reported that a shared neutral conductor in building may carry increased harmonic currents and result in wiring failures [CBEMA, 2001]. The potential problems related to the excessive zero sequence current harmonics in the neutral conductor are [Pekik, A.D., *et.al.*, 1997].

- i. The risk of wiring failure due to improper sizing of the neutral conductor
- ii. Transformer overheating due to harmonic currents
- iii. Excessive neutral current to ground voltage due to a voltage drop caused by neutral current

There are standards that determine the maximum allowable level for each harmonic in the Alternative Current (AC) system [IEEE Std. 519, 1981]. When excessive harmonic voltage and current are generated, filters are usually installed to reduce the harmonic distortion [Fang, Z.P., *et.al.*, 1990, Fang, Z.P., *et.al.*, 1993, Mark, M.G. 2003, Hugh, R., *et.al.*, 2003, Helga, S., 2004]. There are two functions to connect harmonic filter at line distribution systems as listed below.

- i. To reduce the harmonic voltage and current in the AC system below the permitted levels
- ii. To provide some of the reactive power absorbed by the converter system
[IEEE Std. 519, 1981]

Conventionally, passive filters have been used to eliminate harmonic problems. This filter mainly consists of common devices such as inductance and capacitance. These devices tuned to the frequency of the harmonic to be removed. However it has the following limitation.

- i. A separate filter is necessary for each harmonic frequency
- ii. As both the harmonic current and the fundamental frequency current flow into the filter, the capacity of the filter must be decided by taking into account both currents
- iii. The filter will be overloaded when the content of the harmonic in the AC line increases

Other methods of harmonic reduction is considered such as current injected by Active Power Filter (APF) to overcome the above limitation [Charles, A.G. and James, R.J., 1999, El-Habrouk, M., *et.al.*, 2000, Sangsun, K. and Parasad, N.E., 2001, Ambra, S., *et.al.*, 2003]. The APF filter concepts are used power electronic switching to generate harmonics components to cancel the harmonic components of the nonlinear loads. It means that in these devices, Direct Current (DC) is converted to form the harmonic currents out of phase of the load which is then injected into AC line, thereby preventing the harmonics currents flowing into the supply [Arrilaga, J., *et.al.*, 2003].

The suitable device in developing the APF is utilizing Pulse Width Modulation (PWM) inverter by using power semiconductor devices such as Insulated Gate Bipolar

Transistor (IGBT) or Metal Oxide Field Effect Transistor (MOSFET) [Philip, J.A., *et.al.*, 1997]. The PWM is used because it can be easily adjusted in order to control amplitude harmonic current injection and frequency switching.

Following are the reasons APF had been used to minimize harmonic pollution in the distribution line system compared with passive filter.

- i. All the harmonics presented in AC line system can be compensated by using one equipment
- ii. The maximum order of harmonic to be suppressed has no limitation and is determined by PWM switching
- iii. Even the existing harmonic components change in magnitude and frequency in line it can be accommodated by control adjustment by triangular and voltage reference circuit rather than equipment changes from time to time
- iv. It is not designed to filter out one harmonic component only, but is intended to attenuate several harmonics in one time

Compared with passive filter methods, the harmonic current injection into the power network by applied a high frequency switching inverter able to offers suppress harmonic as much as possible adequate with low cost had been reported [Nakajima, *et.al.*, 1988].

In this thesis APF is proposed to minimize the zero sequence current harmonic current as well as to reduce neutral currents magnitudes in three phase four wire systems. Both simulation and experimental works are performed in order to validate the results.

1.2 Objectives

The main objectives of this research are to develop and design APF to reduce the excessive neutral current as well as harmonic currents in neutral wire for three phase four wire distribution systems. The main proposed APF can be outlined as follows:

- i. Development of a new switching strategy control by using single sinusoidal via dual level triangular waveform
- ii. Development of a new automatic control circuit for output-following signal in order the harmonic cancellation is synchronize appropriately with neutral current in neutral conductor
- iii. Development of a new safety precaution for APF
- iv. Complete design, test and prototype for APF modular
- v. Comparison results of the proposed APF between simulation and experimental work

1.3 Project Methodology

At the moment APF is focused for the harmonic current compensation for single and three phase systems [Akagi, H., 1994, Akagi, H., 1996]. It is clearly understood that the development of APF is very complicated. Meanwhile the ABB Company takes initiative to develop APF for three phases from year 1995 till 2004 for commercial purposes but not three phase four wire system [Olivier, S¹. and Olivier, S²., 2004].

This thesis studies the current injected active AC power filter utilizing power semiconductors to cancel excessive neutral current harmonics. A new simple technique in developing a half bridge inverter is the heart of APF had been introduced out. Also a new switching technique, using single sinusoidal waveform via dual level frequencies carrier for strategic control of two switches PWM controlled APF has been

developed. In addition to that the new approached automatic control circuit for output-following signal to improve harmonic cancellation is carried out. Besides that, the new approached of safety precaution for APF is presented. In this research the star delta transformer is employed with APF for application in three phase four wire system.

The performances of the simple APF and new strategy control are investigated by simulation and experiments. Using these results of simulation and experiments, it is possible to optimize the operation of the APF for three phase four wire distribution system.

The new proposed of important aspects in project methodology for neutral current reduction of three phase four wire distribution systems as follows:

- i. Literature review and find the information on APF, nonlinear loads characteristics, current waveform distortion and total harmonic distortion
- ii. Model three phase four wire distribution systems, under normal operating conditions with the nonlinear loads reasonably balanced in order to determine the harmonic currents and excessive neutral current in neutral conductor
- iii. Design and develop the PWM switching strategy control by using single sinusoidal via dual level triangular waveform to cancel triplen harmonics (3^{rd} , 9^{th} , 15^{th} , etc.) in neutral line
- iv. Design and develop the automatic control circuit for output following signal to synchronize between harmonic cancellation with neutral current magnitude in neutral conductor, therefore the reduction of harmonic will be furthered improved
- v. Design and develop the safety precaution circuit so that the whole systems are free from hazards

- vi. To perform simulation and experimental work for data collection of excessive neutral current minimization.
- vii. Analyse the simulation and experimental results

The block diagram for the project methodology can be represented in Figure

1.2.

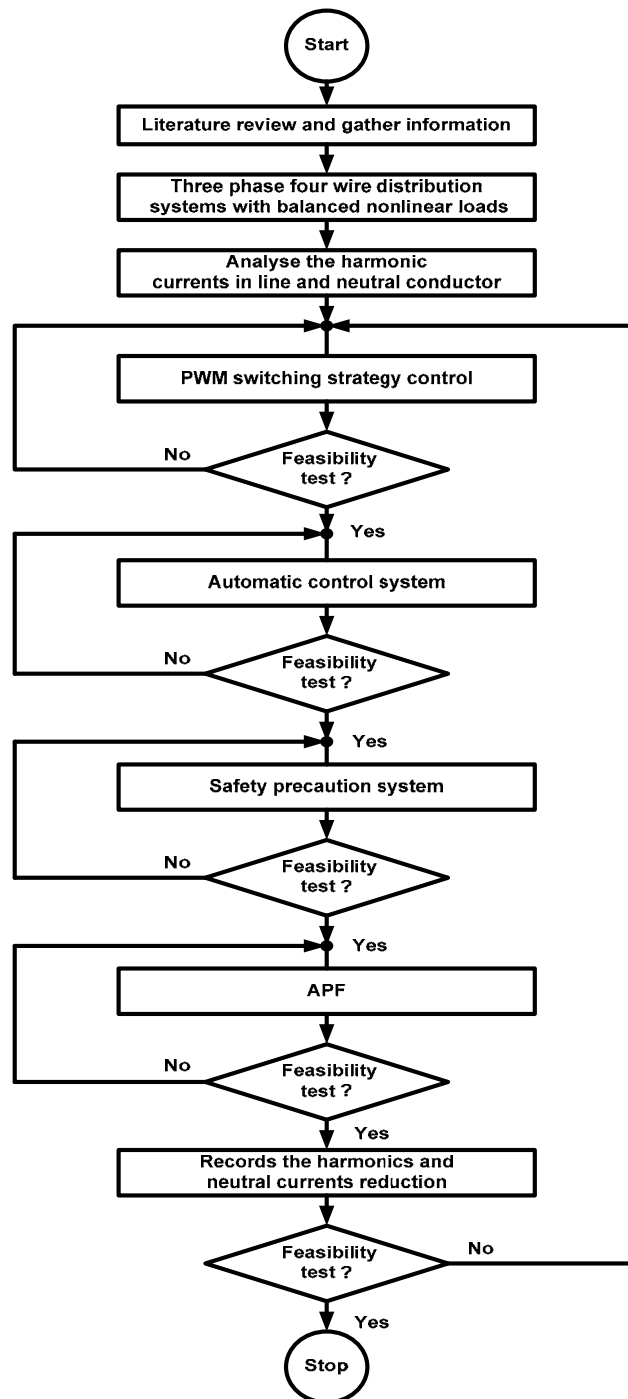

Figure 1.2: Flowchart for Project Methodology

1.4 Scopes and Contributions

This thesis is a contribution to the design and implementation technique for APF in minimizing harmonics currents in neutral conductor for three phase four wire distribution systems. An experimental APF unit rated 1kVA was developed and used for testing and validation purposes. The main scopes of works can be outlined as follows:

- i. The power circuit for APF is a force commutated sinusoidal pulse width modulated voltage source inverter based on half bridge configuration. A new simple circuit, low cost and reliable new switching strategy control are proposed in order to turn-ON and OFF power circuit for APF. The approached implementation uses dual level triangular wave compared with single sinusoidal to generate sharpen sinusoidal pulse width modulation with lower dead time. It is achieved by using high precision voltage comparator and high speed integrators
- ii. The new switching strategy controls along with automatic control circuit for output-following signal are implemented. The proposed implementation uses a new simple and low cost circuit such as light emitting diode and photoresistor technique that allows the operation of switching is synchronized with magnitude neutral current in neutral line in order to achieve better harmonic current cancellation
- iii. The protections in operating system technique are implemented in order to avoid hazard to humans, offers protection from short circuit and over neutral current in neutral line. The proposed implementation uses a simple and low cost controllers such as relay, driver and magnetic contactor

The specific contributions as follows:

- i. A detail design and techniques to develop a new approached APF is presented
- ii. The root mean square (rms) neutral current and harmonic current can be minimized by using a new approached techniques for APF were developed
- iii. The THDi phase currents were reduced
- iv. The power factor in distribution system were improved
- v. Based on the new switching strategy control the periods of life time power switchers is longer and switching power losses is lower. Also, no requires additional circuit for dead time control in order to avoid overlapping gating signal during power switchers turn-ON and OFF. Beside that no short-through problems between upper and lower of power switchers
- vi. Due to automatic control circuit the harmonic current reduction can be furthered improved
- vii. The safety precaution circuits were developed in APF instead of Miniature Circuit Breaker (MCB) to protect the potential hazards to humans and electrical circuit from damage caused by electrical faults in power systems
- viii. The sized and weight of APF is less compared to the passive filter

Research work in this thesis has produced several publications in various conferences as follows:

- i. Izhar, M., Hadzer, C.M. and Syafrudin, M. (2003). Preliminary of Closed Loop Harmonic Study Analysis in Under Load Variations for Power

- System. *IEEE Proceedings of the International Conference On Robotics, Vision, Information and Signal Processing*. 1. 675 – 682.
- ii. Izhar, M., Hadzer, C.M. and Syafrudin, M. (2003). Reduced Order Model of a Switched Capacitor Design. *IEEE Proceedings of the International Conference On Robotics, Vision, Information and Signal Processing*. 1. 683 – 689.
 - iii. Izhar, M., Hadzer, C.M. and Syafrudin, M. (2003). An Analysis of the Harmonic Effect to Power Factor in the Power System. *IEEE Proceedings Engineering and Technology Conference*. 407 – 414.
 - iv. Izhar, M., Hadzer, C.M. and Syafrudin, M. (2003). A Study of the Fundamental Principles to Power System Harmonics. *IEEE National Power Engineering Conference Proceedings*. 225 – 232.
 - v. Izhar, M., Hadzer, C.M. and Syafrudin M. (2003). An Investigation on Harmonic Level, Current & Voltage Distortion and Associated Power for Three Phase Four Wire Distribution System in a USM Electrical & Electronic Engineering Department Building. *IEEE National Power Engineering Conference Proceedings*. 371 – 378.
 - vi. Izhar, M., Hadzer, C.M. and Syafrudin, M. (2004). Harmonics Reduction Performance of Passive and Active Power Filter in Distribution System. *Proceedings 6th Industrial Electronics Seminar, JICA-IEEE*, Oct. 42 – 46.
 - vii. Izhar, M., Hadzer, C.M. and Syafrudin, M. (2004). An Analysis and Design of A Star Delta Transformer In Series With Active Power Filter for Current Harmonics Reduction. *IEEE National Power & Energy Conference*, Dec. 94 – 98.
 - viii. Izhar, M., Hadzer, C.M. and Syafrudin, M. (2004). Performance for Passive and Active Power Filter in Reducing Harmonics in the Distribution System. *IEEE National Power & Energy Conference Proceedings*, Dec. 104 – 108.

1.5 Thesis outline

This thesis is organized as follows:

Chapter 2 covers the background and literature reviews. In this Chapter also describes the harmonics as a power quality problem such as sources and effect

harmonics in the power systems, harmonic reduction technique, includes survey of the active filtering technique is discussed.

Chapter 3 describes and discusses in detail on the design and implementation circuit technique in order to develop APF to reduce rms neutral current as well as harmonic currents in neutral conductor for three phase four wire distribution system. Also, the simulation results are examined to validate the design proposed

Chapter 4 explains on the experiment results and discusses from the beginning to the end of development for APF. Both simulation and practical results are demonstrated to verify the proposed approach

Chapter 5 concludes the thesis and identifies some area for future research work

At the end of the thesis, a list of relevant references and appendices are given.

CHAPTER 2 BACKGROUND AND LITERATURE REVIEW

2.1 Introduction

Ideally, all power utilities should provide their customers with a quality supply which has constant magnitude and frequency of sinusoidal voltage. Unfortunately it is a hard task to maintain this quality supply for constant magnitude and frequency of sinusoidal voltage. In reality the supply waveforms are always got distorted resulting in supply or not purely sine wave due to nonlinear load. The common nonlinear loads nowadays such as variable speed drivers, rectifiers, Uninterruptible Power Supplies (UPS), Personal computers (PC), Television (TV) sets etc. These loads draw current from the sources which do not follow the voltage shape and hence introduce harmonic [Bachry, A., *et.al.*, 2000, [Power Notes-Power System Harmonics, 2003](#)]. Harmonics in power distribution system are current or voltage that are integer multiples of fundamental frequency. For example, if the fundamental frequency 50 Hz, then the 2nd harmonics is 100Hz, the 3rd is 150Hz etc. [Robert, D.H., *et.al.*, 1994]. These harmonics are growing problem for both electricity suppliers and users [Tom, S., *et.al.*, 1995, Mansoor, A. and Grady, W.M., 1998, Grady, W.M., *et.al.*, 2002].

Harmonics are usually defined as sinusoids of any frequency other than the AC power system fundamental frequency. There are two types of harmonics that can be encountered in a power system [[IEEE Std. 100-1988](#)].

- i. Synchronous harmonics
- ii. Asynchronous harmonics

Synchronous harmonics are sinusoids with frequencies which are multiples of the fundamental frequency. The multiplication factor is often referred to as the harmonic number. The synchronous harmonics can be subdivided into two categories.

- i. Subharmonic when the harmonic number is less than one
- ii. Superharmonic when the harmonic number is greater than one

For example, the line current contains both subharmonic and superharmonic such as cycloconverters and line commutated three phase thyristor based rectifiers. These waveforms are considered as distortion [[Leon, M.T., et.al., 2003](#), [Chang, G., et.al., 2004](#)].

Asynchronous harmonics are those sinusoids which do not maintain a frequency relationship with the fundamental frequency sinusoid. These sinusoids never exhibit a constant harmonic number and similarly do not maintain a stationary phase relationship with the fundamental frequency sinusoid.

Harmonics as a power quality problem which is perturbed in the power systems is first discussed in Section 2.1. Sections 2.2 and 2.3 highlight the causes and the impact of the harmonic problems. The limits of harmonic and overview on harmonic mitigation techniques, with emphasis on the APF filtering solution is given in Section 2.4 and 2.5 respectively. Meanwhile, Section 2.6 will further discuss on the literature review on APF.

2.2 Harmonics as a Power Quality Problem

Harmonics are qualitatively defined as sinusoidal waveforms having frequencies that are integer multiples of the power line frequency. In power system engineering, the term harmonics is widely used to describe the distortion for voltage or current

waveforms. The harmonic problem is not a new phenomenon in power system. It was detected as early as the 1920s and 30s [[IEEE Working Group On Power System Harmonic: An Overview, 1983](#), [Hirofumi, A., 1994](#)]. At the time, the primary sources of harmonics were the transformers and the main problem was inductive interference telephone systems. Some early investigation work on harmonic filtering in distribution feeders was performed around that time.

Harmonic distortion can have detrimental effects on electrical distribution systems. It can waste energy and lower the capacity of an electrical system [[Heydt, G.T., et.al., 1994](#)]. Understanding the problems associated with sources and effects of harmonics as well as the methods to reduce the harmonic will increase the overall efficiency of the distribution system [[Kassakian, J.G., et.al., 1991](#), [Kendall, P.G., 1992](#)].

2.3 Sources of Harmonics

Figure 2.1 illustrate the different sources of harmonics in power distribution system. The different sources of harmonics namely from three main areas as listed below.

- i. From the fast switching associated of power electronic devices
- ii. From the conventional sources such as electrical rotating machines and transformers
- iii. From modern electronic equipments

2.3.1 Harmonics from Fast Switching of Power Electronic Devices

Nowadays, due to the applications advanced technologies in industrial sectors such as power semiconductor systems which are designed using phase controlled or uncontrolled rectifiers, inverters, AC voltage controllers, cycloconverter and converters.

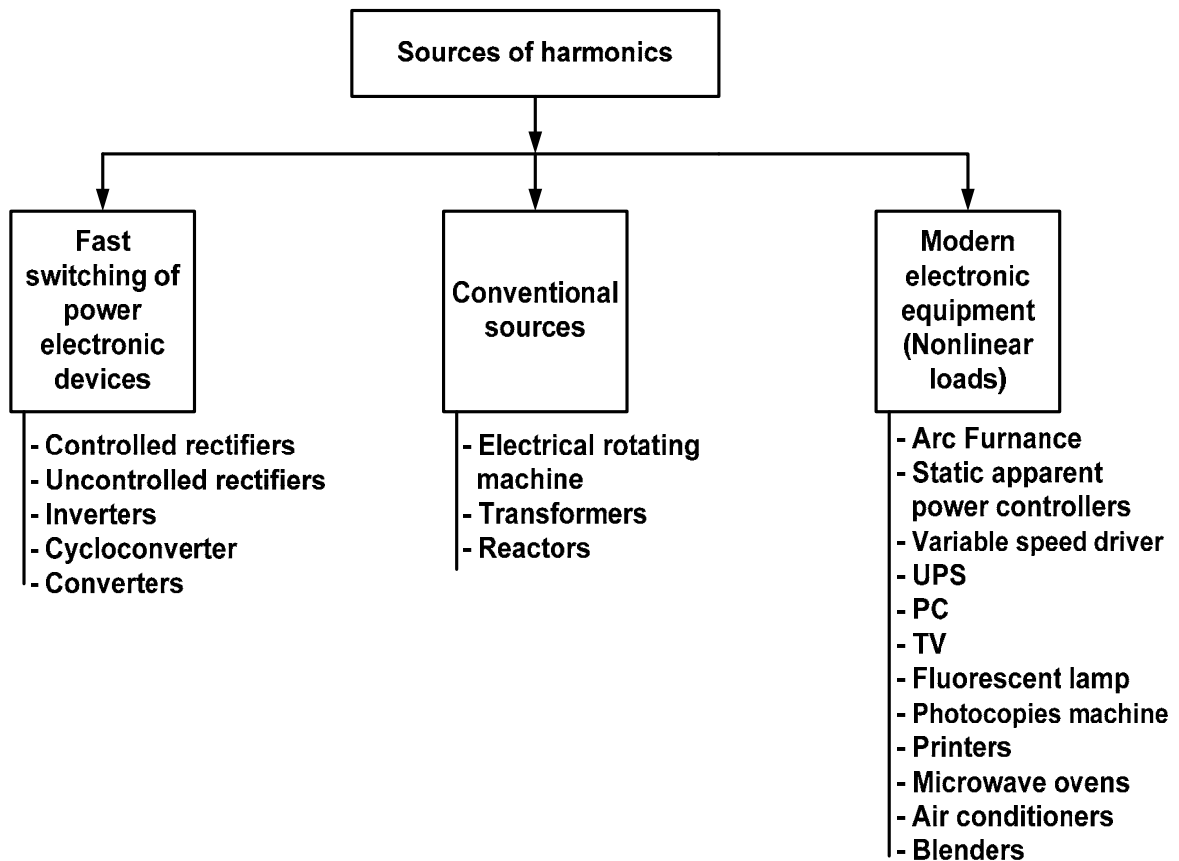

Figure 2.1: The Sources of Harmonics In Power Distribution System

In single phase full wave controlled rectifiers the harmonic generated are more significant at lower frequency compared with higher frequency [Dubey, *et.al.*, 1986, Ned, M., *et.al.*, 1995, Yasuyuki, N., *et.al.*, 1997]. Meanwhile, the three phase controlled rectifiers is used for high power with large Mega Volt Ampere (MVA) rating [Farhad, N. and Patel, H.S., 1988, Karshenas, H.R., *et.al.*, 1995] it produces large harmonics currents on 3rd, 5th, 7th, 9th, 11th, 13th, 15th, 17th and 19th harmonics [Philips, J.K., *et.al.*, 1991]. Others applications of thyristor controlled rectifiers such as:

- i. To control the acceleration and deceleration of electric engine can cause current distortion including order 3rd, 5th and 7th harmonic currents is directly injected into utility [Zhongming, Y., *et.al.*, 2000, Shoofeng, X., *et.al.*, 2003]

- ii. To control the speed of portable hand tool driver. The 3rd harmonics is dominant harmonic which contributed to the power distribution systems [Mack, G. and Santoso, S., 2001]
- iii. To establish a voltage level in providing the gate current to turn on and off the thyristor for home and industry applications such as light dimmer and induction motor. The 3rd harmonics is dominant harmonic into power distribution system [Emanuel, A.E., *et.al*, 1980, Daniel, W.H., 1997]
- iv. To control mine winders, draglines, electrical shoves, electrochemical and metallurgical plants. It founds that the almost harmonic current is 5th, 7th and 11th harmonics. It's rare to find the 3rd, 9th, or 15th harmonics [A Gold Mine of Troubleshooting, 2003, Pacific Gas and Electric Company,2003]
- v. To control variable speed motor drives. Effects from this phenomenon will be served the main contributor harmonic distortion in supply system is 3rd, 5th and 7th harmonic currents [Sadeq, A.H., 1997]
- vi. To vary the AC voltage controller for lighting control, variable transformer by using taps changing, heater, industrial heating and induction motor. By controlling the phase delay of the thyristor the load currents are varied within desired limits. This result will effect in distorted input current and simultaneously significant harmonic current such as 3rd, 5th, 7th, 9th and 11th is generated and injected into the supply system [Abou-Elala M. and Alolah A.I., 1994, Czarnecki, L.S and Tan, O.T., 1994, Grady, W.M., *et. al.*, 1994, Kamath, G., *et.al.*, 1995, Grady, W.M., *et. al.* 2002, Hashem, G.M. and Darwish, M.K., 2004].

An identically the constructions circuits for uncontrolled rectifiers of single phase and three phase were similar with controlled rectifiers. The different is that diodes are used for uncontrolled rectifiers compared with thyristor for phase controlled rectifiers. The circuit is shown in Figure 2.2

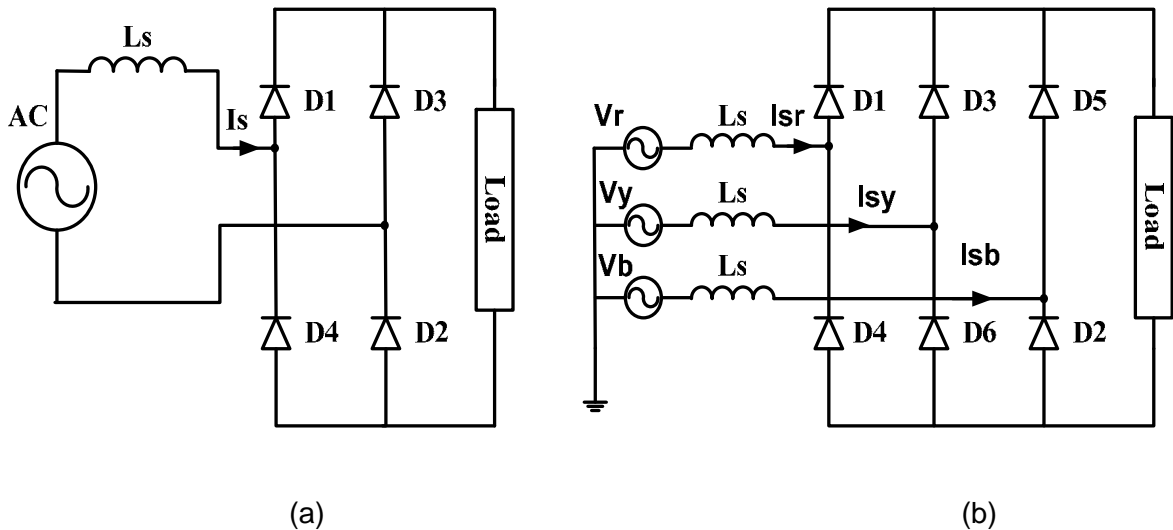

Figure 2.2: Uncontrolled Rectifiers (a) Single Phase (b) Three Phase

These rectifiers are mainly used in DC power supplies. Most the above configuration circuits are used to convert AC supply to DC supply. This DC supply is used for internally circuits. Both single phase and three phase diode rectifiers injects large amounts of harmonic currents into the utility system. It means that this is the major contributors of harmonic in the supply system [Ned, M. *et.al.*, 1995].

The single and three phase inverters are commonly used to convert DC to AC power at some desired output voltage and frequency. The output voltage, current and frequency of inverter can be controlled by control strategies of inverters [Lai, J.S., *et.al.*, 1994, Von, J., *et.al.*, 1995, Akira, N., *et.al.*, 1996, Evon, S.T and Oakes, B., 1999, Vazquez, N., *et.al.*, 1999, Ahmad, F.R. and Omar, A.M., 2005]. However, in practically inverters outputs contain certain harmonics. With the availability of high speed power semiconductors devices, the harmonic contents of the output voltage and current can

be minimized significantly by switching technique and additional passive filters to be used [[Liang, T.J., et.al., 1997](#)].

AC-AC conversion such as cycloconverter can be used to control the low speed of induction motor and AC motor drives in the range up to 15kW with frequencies from 0 to 50Hz. It is shown that this application suitable for low speed and very large horsepower applications. It is shown that this application suitable for low speed and very large horsepower applications. The harmonics currents on 3rd, 5th, 7th and 11th including interharmonics from cycloconverters are injected into power network and caused the current distortions [[Muhammad, H.R., 1993](#), [Ned, M. et.al., 1995](#), [Jiang, J. and Xie, W. 2000](#), [Pontt, J., et.al., 2003](#)].

Next, the converters are mainly consists of power electronics devices and widely used in the industry to convert one type of signal to another form. The summary for type's converters and their functions are tabulated in Table 2.1. The alternating current drawn from the main supply by a converter, theoretically contain harmonics are represented by $(mk \pm 1)$, where m is the pulse number (number of pulses of current that pass through the load circuit during one cycle of the source voltage) and k is any integer. It means that a 6 pulses thyristor controlled converter will theoretically contains 3rd, 5th, 7th, 11th, 13th,...etc. harmonics, 12 pulse converter will theoretically contains the 11th, 13th, 23rd, 25th,...etc. harmonics and 24 pulse converter will theoretically contains the 23th, 25th, 47th, 49th...etc. harmonics [[IEEE Std. 519, 1981](#)].

Hence, the fast switching of power electronics were created significant amount of harmonic pollution in the power distribution systems is greater than compared with the conventional sources. It is predicted that in future more than 60% of the industrial loads will be controlled by power electronics [[Lamarre, L., 1991](#)].

Table 2.1: Types and functions of converter

No.	System	Function
1.	Rectifiers i. Controlled	Fixed voltage AC supplied to variable voltage DC
	ii. Uncontrolled	Fixed voltage AC supplied to fixed voltage DC
2.	Inverters i. Controlled	Fixed voltage DC supplied to fixed voltage AC
	ii. Uncontrolled	Fixed voltage DC supplied to variable voltage AC
3.	AC voltage controllers	Fixed voltage AC supplied to variable voltage AC
4.	Cycloconverters	Fixed frequency AC to variable frequency and variable voltage AC
5.	DC / DC Converter (Chopper)	Fixed voltage DC supplied to variable voltage DC

2.3.2 Harmonic from Conventional Sources

Over the past decade, some electric power facility such as electrical rotating machine, transformer and reactor will be injected harmonic current into power distribution system. Effect from this the electric current drawn by these devices is non sinusoidal which contain a lot of harmonics. Therefore, this harmonics current can produce problems such as vibration and overheated to that device respectively [Bishop, M.T., *et.al.*, 1996].

A basically an electrical rotating machines are injected harmonic into power system. The generated harmonic by electrical rotating machines can be discussed as follows.

i. Non-Symmetrical voltage supply

If a balanced three phase voltages are applied to the stator of induction and synchronous motor, a rotating magnetic flux is produced. This flux passes through air gap, rotor surface and cutting rotor conductors to produce rotation. The rotation of rotor can be forward and backward based on the method how three phase voltage terminal is connected [Theraja, B.L., 1984], Theodore, R.B., 1997]. Furthermore, by using the symmetrical components technique, the performance of unbalanced three phase voltage and currents from unbalanced faults can be analysed [Hadi, S.,1999]. Any vectors of unbalanced three phase system can be resolved into three sequences. Firstly, a positive sequence, secondly, a negative sequence and lastly a zero sequence voltage in order to relate harmonic in the three phase system [Barners R., 1989].

Let a three phase alternator which identical phases winding Red, Yellow and Blue in which harmonics are generated. The three phase current will be represented in phase sequence by the following equations [Theraja, B.L., 1984, Pejovic, P. and Janda, Z., 1999].

$$i_R(t) = I_{1m} \sin(\omega t + \phi_1) + I_{3m} \sin(3\omega t + \phi_3) + I_{5m} \sin(5\omega t + \phi_5) + \dots \quad (2.1)$$

$$i_Y(t) = I_{1m} \sin\left(\omega t - \frac{2\pi}{3} + \phi_1\right) + I_{3m} \sin\left[3\left(\omega t - \frac{2\pi}{3}\right) + \phi_3\right] + I_{5m} \sin\left[5\left(\omega t - \frac{2\pi}{3}\right) + \phi_5\right] + \dots \quad (2.2)$$

$$i_B(t) = I_{1m} \sin\left(\omega t - \frac{4\pi}{3} + \phi_1\right) + I_{3m} \sin\left[3\left(\omega t - \frac{4\pi}{3}\right) + \phi_3\right] + I_{5m} \sin\left[5\left(\omega t - \frac{4\pi}{3}\right) + \phi_5\right] + \dots \quad (2.3)$$

where,

i_R is the current for phase R

i_Y is the current for phase Y

i_B is the current for phase B

I_{1m} is the amplitude of fundamental current

I_{nm} is the amplitude of n^{th} harmonic current

ϕ_1 is the phase angel of fundamental current

ϕ_n is the phase angel of n^{th} harmonic

$f = \frac{\omega}{2\pi}$ is the frequency of fundamental current

Simplified Equation (2.2) and Equation (2.3) become

$$i_Y(t) = I_{1m} \sin\left(\omega t - \frac{2\pi}{3} + \phi_1\right) + I_{3m} \sin(3\omega t + \phi_3) + I_{5m} \sin\left[5\left(\omega t - \frac{4\pi}{3}\right) + \phi_5\right] + \dots \quad (2.4)$$

$$i_B(t) = I_{1m} \sin\left(\omega t - \frac{4\pi}{3} + \phi_1\right) + I_{3m} \sin(3\omega t + \phi_3) + I_{5m} \sin\left[5\left(\omega t - \frac{2\pi}{3}\right) + \phi_5\right] + \dots \quad (2.5)$$

It can be seen from Equation (2.1), (2.4) and (2.5) that all third harmonics are equal in all phase. The fifth harmonics have a backward rotating, in nature as a negative sequence. Further, all harmonics which are not multiples of three have phase displacement of 120° . Therefore, the harmonic sequence is tabulated in Table 2.2.

Table 2.2: Harmonics phase sequences for three phase power system

Harmonic Number	1	2	3	4	5	6	7	8	9	10	11	12	13	14	15
Harmonic Sequence	+	-	0	+	-	0	+	-	0	+	-	0	+	-	0

In general it can be shown that the positive sequence current is related to the $(3k+1)^{\text{th}}$ harmonic, negative sequence current is related to the $(3k-1)^{\text{th}}$ harmonic and zero sequence current is $3k$ harmonic, where k is any integer. In the same way it can be shown that:

1. All triple-n harmonics are in phase i.e 3^{rd} , 9^{th} , 15^{th} , etc
2. The 7^{th} , 13^{th} and 19^{th} harmonics have a positive phase sequence
3. The 5^{th} , 11^{th} , and 17^{th} harmonics have a negative phase sequence

ii. Unequal loading in three phase

If three phases are not equally loaded (unbalanced system), negative and zero sequence currents will be generated which are related to the $(3k-1)^{\text{th}}$ and $3k$ harmonics [[Modern Rectifiers and Power System Harmonics, 2004](#)].

iii. Anomalies in machine specifications

In general the rotors of AC machines have defects such as on their couple unbalance, angular misalignment, bad shaft, misalignment bearing, mechanical looseness, sleeve bearing wear, rotor & stator rub, cleanliness problems and winding surface is not efficient. All these anomalies criteria's can be caused in generating harmonic for electrical machines [[Vibration Diagnostics Chart, 2003](#)].

iv. Non sinusoidal distribution of the flux in the air gap.

In principal all machine are controlled by voltage or current source inverters. The machines currents are therefore nonsinusoidal. It will flows through winding of a phase. As a result the Electromotive Force (e.m.f) produced is non sinusoidally and simultaneously

distributed in the air gap between rotor and stator. This air gap flux, therefore, consists of fundamental and harmonic components of fluxes. This phenomenon will increase the pollution of harmonic in the power system [Paresh, C.S., 1997, Charles, H. 2004].

The nonlinear load characteristics of the iron core transformer generate odd current harmonics due to nonlinear character of the Flux Density (B) and Magnetic Field Intensity, (H). (B-H curve) and hysteresis loop in the excitation current is shown in Figure 2.3.

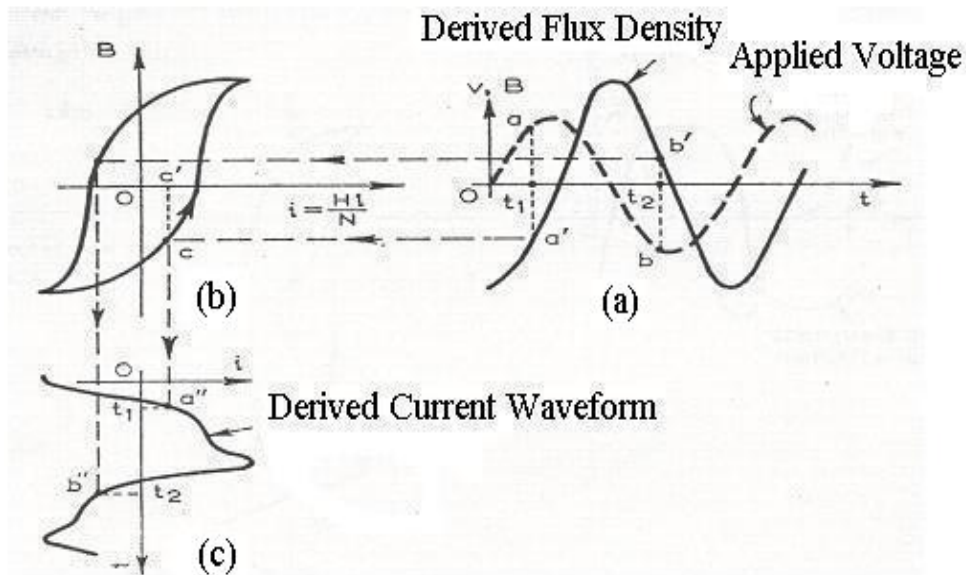

Figure 2.3: Waveforms in Iron Cored Transformer (a) Applied voltage (b) B-H Curve (Hysteresis loop) (c) Current through an iron cored transformer

It is seen that the current curve has identical positive and negative half cycles, so that it contains no even harmonics [Paresh, C.S., 1997, Calvert, J.B., 2001]. The measurement shows that the 3rd (72%) harmonic currents are dominates for excitation current compared with others harmonics order 5th (45%), 7th (25%), 9th (12%), 11th (5%), 13th (2%) of a distribution transformer [Ahsan, H., et.al., 1999].