

VOLUMETRIC STUDIES OF LECITHIN-WATER DISPERSIONS

YEAP PEI KOON

UNIVERSITI SAINS MALAYSIA

2007

VOLUMETRIC STUDIES OF LECITHIN-WATER DISPERSIONS

by

YEAP PEI KOON

**Thesis submitted in fulfilment of the requirements
for the degree of
Master of Science**

March 2007

ACKNOWLEDGMENTS

First and foremost, I would like to gratefully acknowledge Professor Lim Koon Ong for his supervision of the research and for his generous advice and assistance during the preparation of this thesis. I would also like to thank Professor Teng Tjoon Tow for his encouragement and helpful suggestions during the course of this research. Also, I wish to thank Professor Abdul Rahman Mohamed for his guidance and help rendered throughout this research work. The assistance and invaluable attention of Professor Chong Chon Sing, my initial supervisor, in developing and formulating the ideas in this study is gratefully acknowledged.

I am profoundly indebted to the teaching assistantship provided by the School of Physics, Universiti Sains Malaysia during the early part of this research. I would like to take the opportunity here to thank the School of Physics, School of Industrial Technology, as well as the School of Chemical Engineering, Universiti Sains Malaysia for the use of the facilities and to the staff members of these schools for their assistance and service rendered to me.

Finally, I wish to express my gratitude to my parents, sister and brother for their prayers and patience. And I would also like to thank my faithful friend, Chew Chai Jin for his continuous encouragement and moral support throughout these years.

TABLE OF CONTENTS

	Page
ACKNOWLEDGMENTS	ii
TABLE OF CONTENTS	iii
LIST OF TABLES	vii
LIST OF FIGURES	ix
ABSTRAK	xiv
ABSTRACT	xvi
CHAPTER 1 GENERAL INTRODUCTION	
1.1 Introduction	1
1.2 Studies on Liposomes	10
1.3 Objectives and Scope of Present Work	14
1.4 Organization of Thesis	15
CHAPTER 2 LIPOSOMES (LIPID VESICLES)	
2.1 Introduction	17
2.2 Structure of Liposomes	18
2.3 Preparation of Liposomes	19
2.3.1 Multilamellar Liposomes (MLVs)	19
2.3.2 Small Unilamellar Liposomes (SUVs)	20
2.3.3 Large Unilamellar Liposomes (LUVs)	21
2.3.4 Sonication	23
2.4 Applications Involving Liposomes	24
2.4.1 Liposomes Use as Vaccine Carriers	29
2.4.2 Liposomes Use as Antimicrobials	30

2.4.2 (a)	Bacterial	30
2.4.2 (b)	Parasitic	31
2.4.2 (c)	Fungal	32
2.4.2 (d)	Viral	32
2.4.3	Liposomes in Cancer Treatment	33
2.4.4	Liposomes in Oxygen Transport	34
2.4.5	Liposomes in Enzyme Replacement Therapy	34
2.4.6	Liposomes in Metal Poisonings	35
2.4.7	Liposomes to Inhibit Immune Reactions	35
2.4.8	Liposomes in Cosmetics	35
2.5	Polymorphism and Thermotropic Phase Transition	36
2.6	Size Determination	39
2.6.1	Turbidity Measurement Technique	40
2.7	Density Determination	43
2.8	Ion Effects	44
 CHAPTER 3 THEORETICAL CONSIDERATIONS		
3.1	Introduction	47
3.2	Theoretical Approach	47
3.3	Effect of Addition of Salt	51
 CHAPTER 4 MATERIALS AND METHODS		
4.1	Introduction	52
4.2	Materials	52
4.3	Preparation of Samples	52
4.4	Turbidity Measurements	54
4.5	Density Measurements	55

4.5.1	Calibration Calculation	56
4.5.2	Calibration Procedure	57

CHAPTER 5 RESULTS AND DISCUSSION

5.1	Introduction	59
5.2	Estimation of Liposome Sizes by Turbidity Measurements	60
5.2.1	Effect of Sonication	60
5.2.2	Estimation of Liposome Sizes in Lecithin Dispersions	66
5.2.2 (a)	Dispersions with Different Concentrations of Lecithin	66
5.2.2 (b)	Effect of Calcium Ions	68
5.2.2 (c)	Effect of Sodium Ions	70
5.3	Temperature Dependence of Density	71
5.3.1	Dispersions with Different Concentrations of Lecithin	71
5.3.2	Lecithin Dispersions with Addition of CaCl ₂ Salt Solution	77
5.3.3	Lecithin Dispersions with Addition of NaCl Salt Solution	82
5.3.4	Discussion	86
5.4	Theoretical Calculation of Effective Molecular Volume	106
5.4.1	Variation with Lecithin Concentration	107
5.4.2	Effect of Calcium Ions	111
5.4.3	Effect of Sodium Ions	123
5.5	Summary and Discussion	131

CHAPTER 6 SUMMARY AND CONCLUSIONS

6.1	Summary	136
6.2	Conclusions	136
6.3	Recommendations for Future Research	139

REFERENCES	140
APPENDIX 1 THEORETICAL CONSIDERATIONS FOR THE ERROR IN THE DENSITY ARISING FROM ERROR IN SAMPLE VOLUME OF WATER	149
LIST OF PUBLICATIONS	152

LIST OF FIGURES

		Page
Figure 1.1	Comparison of eukaryotic cell and prokaryotic cell.	2
Figure 1.2	Comparison of cytoplasm and cytosol. (a) Cytoplasm (colored area) is the region of the cell outside the nucleus. (b) Cytosol (colored area) is the fluid surrounding the cell organelles.	2
Figure 1.3	Schematic representations of the Davson-Danielli-Robertson model (adapted from Harrison and Lunt, 1975).	4
Figure 1.4	Schematic representation of the fluid mosaic model of membrane structure. (a) Cross-sectional view. The phospholipids are arranged in a discontinuous bilayer. (b) Three-dimensional view. The globular proteins are partially embedded in a phospholipid bilayer (adapted from Singer and Nicolson, 1972).	4
Figure 1.5	Arrangement of integral and peripheral membrane proteins in association with a lipid (phospholipid) bilayer (adapted from Widmaier et al., 2004).	5
Figure 1.6	Glycerol and fatty acids are the major subunits that combine to form phospholipids. (a) Arrangement of subunits in phospholipids. (b) Structure and formula for a common membrane phospholipid, phosphatidylcholine. (c) Space-filling model of phosphatidylcholine. (d) Diagram used to depict a phospholipid molecule.	6
Figure 1.7	Bilayer arrangement of phospholipids.	7
Figure 1.8	Three of the most frequently used model membrane systems. (a) Monolayers at the air-water interface. (b) Bilayers. (c) Vesicles or liposomes.	8
Figure 1.9	Schematic representation of the study of black lipid membranes. (a) Simple experimental design showing a plastic septum with an aperture in the centre. The bilayer membrane covers the aperture and separates the two aqueous phases. (b) The black lipid membrane is prepared by applying membrane-forming solution across the aperture in the plastic septum. After thinning over a period of about 15 min, the final bilayer membrane can be observed as the hydrocarbon torus held on at the edge of the aperture. It appears black in reflected light.	10
Figure 1.10	Multilamellar liposomes dispersed in excess water.	11
Figure 2.1	Structure of liposome formed by phospholipids. Note that the central region consists of polar head groups of the inner and bottom surfaces and not a solid mass of polar head groups.	18

Figure 2.2	Contact-mediated transfer mechanisms, (a) intermembrane transfer, and (b) contact-release. Liposome binding to cells with (d) and without (c) uptake. In some cases (c), liposomes may remain passively adsorbed on the cell surface with complete retention of the aqueous and lipid contents within the liposome, separate from the cell. In other cases (d), fusion may take place with incorporation of the liposomal lipids into the cell membrane, and introduction of liposomal contents into the cytoplasm. Uptake of liposomes by (e) phagocytosis. The adsorption stage (i) is followed by invagination of the cell membrane and envelopment of the liposome by plasma membrane (ii), to form an endocytic vacuole, in which the liposome is brought into contact with lysosomal enzymes (iii) (adapted from New et al., 1990).	26
Figure 2.3	Phase diagram of dipalmitoyl lecithin-water system (adapted from Chapman et al., 1967).	37
Figure 2.4	Size-turbidity dependence for an egg L- α -phosphatidylcholine vesicle suspension at 1 mg/ml. Turbidity was measured at two wavelengths; $\lambda = 440$ nm for circle symbols and $\lambda = 780$ nm for square symbols. Closed symbols denote size standards. It should be noted that the value of turbidity referred to as A is in fact the definition of absorbance (adapted from Pozharski et al., 2001).	42
Figure 4.1	Pictorial diagram of the vibrating-tube Anton Paar Density Meter DMA 58.	55
Figure 5.1	Effect of time of sonication on the absorbance-wavelength dependence for lecithin dispersion with concentration of 1 mg/ml.	61
Figure 5.2	Effect of time of sonication on the absorbance-wavelength dependence for lecithin dispersion with concentration of 2 mg/ml.	62
Figure 5.3	Change of absorbance for two concentrations of lecithin in the dispersions. The symbol (*) indicates the repeated set for these two concentrations of lecithin in the dispersions.	65
Figure 5.4	Absorbance as a function of wavelength for dispersions with different concentrations of lecithin.	67
Figure 5.5	Density of lecithin dispersion as a function of concentration of lecithin in dispersion at different temperatures.	72
Figure 5.6	Temperature dependence of the fractional change of density for dispersions with different concentrations of lecithin.	74
Figure 5.7	Fractional change of density as a function of concentration of lecithin in dispersion at 25 °C and 50 °C.	75

Figure 5.8	Fractional change of density for two concentrations of lecithin in the dispersions. The symbol (*) indicates the repeated set for these two concentrations of lecithin in the dispersions.	76
Figure 5.9	Fractional change of density as a function of temperature for lecithin dispersions with the addition of CaCl ₂ salt solution. Ratio indicates the molar ratio of lecithin (fixed at 1 mg/ml) to the CaCl ₂ salt in the dispersion.	78
Figure 5.10	Fractional change of density as a function of temperature for lecithin dispersions with the addition of CaCl ₂ salt solution. Ratio indicates the molar ratio of lecithin (fixed at 2 mg/ml) to the CaCl ₂ salt in the dispersion.	79
Figure 5.11	Fractional change of density for two sets of molar ratio of lecithin (fixed at 1 mg/ml) to the CaCl ₂ salt, where CaCl ₂ salt solution was either added before or after the sonication.	80
Figure 5.12	Fractional change of density for two sets of molar ratio of lecithin (fixed at 2 mg/ml) to the CaCl ₂ salt, where CaCl ₂ salt solution was either added before or after the sonication.	81
Figure 5.13	Fractional change of density as a function of temperature for different molar ratios of lecithin to the CaCl ₂ salt (fixed at 2.04 mM) in the dispersions. The concentrations of lecithin respectively are 1 mg/ml, 1.5 mg/ml, 2 mg/ml, 2.5 mg/ml and 3 mg/ml.	83
Figure 5.14	Fractional change of density as a function of temperature for lecithin dispersions with the addition of NaCl salt solution. Ratio indicates the molar ratio of lecithin (fixed at 1 mg/ml) to the NaCl salt in the dispersion.	84
Figure 5.15	Fractional change of density as a function of temperature for lecithin dispersions with the addition of NaCl salt solution. Ratio indicates the molar ratio of lecithin (fixed at 2 mg/ml) to the NaCl salt in the dispersion.	85
Figure 5.16	Comparison density data of CaCl ₂ salt solution at 25 °C.	89
Figure 5.17	Comparison density data of NaCl salt solution at 25 °C.	90
Figure 5.18	Comparison of data between fractional change of density (I) and (II) for different molar ratios of lecithin (fixed at 1 mg/ml) to the CaCl ₂ salt in the dispersions.	92
Figure 5.19	Comparison of data between fractional change of density (I) and (II) for different molar ratios of lecithin (fixed at 2 mg/ml) to the CaCl ₂ salt in the dispersions.	94
Figure 5.20	Comparison of data between fractional change of density (I) and (II) for different molar ratios of lecithin (fixed at 1 mg/ml) to the NaCl salt in the dispersions.	97

Figure 5.21	Comparison of data between fractional change of density (I) and (II) for different molar ratios of lecithin (fixed at 2 mg/ml) to the NaCl salt in the dispersions.	99
Figure 5.22	Comparison of data between effect of Ca^{2+} ions and effect of Na^+ ions on the liposomes generated in the lecithin dispersions. Ratio indicates the molar ratio of lecithin (fixed at 1 mg/ml) to the salts in the dispersion. The addition of salt solution of CaCl_2 and NaCl are represented by symbols (') and ("), respectively.	102
Figure 5.23	Comparison of data between effect of Ca^{2+} ions and effect of Na^+ ions on the liposomes generated in the lecithin dispersions. Ratio indicates the molar ratio of lecithin (fixed at 2 mg/ml) to the salts in the dispersion. The addition of salt solution of CaCl_2 and NaCl are represented by symbols (') and ("), respectively.	104
Figure 5.24	Volume of lecithin in dispersion as a function of temperature for dispersions with different concentrations of lecithin.	108
Figure 5.25	Volume of lecithin in dispersion as a function of concentration of lecithin in dispersion at 25 °C and 50 °C.	109
Figure 5.26	Total volume of lecithin cum salt in dispersion as a function of temperature for lecithin dispersions with the addition of CaCl_2 salt solution. Ratio indicates the molar ratio of lecithin (fixed at 1 mg/ml) to the CaCl_2 salt in the dispersion.	113
Figure 5.27	Total volume of lecithin cum salt in dispersion as a function of temperature for lecithin dispersions with the addition of CaCl_2 salt solution. Ratio indicates the molar ratio of lecithin (fixed at 2 mg/ml) to the CaCl_2 salt in the dispersion.	114
Figure 5.28	Total volume of lecithin cum salt in dispersion as a function of concentration of CaCl_2 salt solution in lecithin dispersions with concentration of 1 mg/ml at 25 °C and 50 °C.	115
Figure 5.29	Total volume of lecithin cum salt in dispersion as a function of concentration of CaCl_2 salt solution in lecithin dispersions with concentration of 2 mg/ml at 25 °C and 50 °C.	116
Figure 5.30	Total volume of lecithin cum salt in dispersion for two sets of molar ratio of lecithin (fixed at 1 mg/ml) to the CaCl_2 salt, where CaCl_2 salt solution was either added before or after the sonication.	117
Figure 5.31	Total volume of lecithin cum salt in dispersion for two sets of molar ratio of lecithin (fixed at 2 mg/ml) to the CaCl_2 salt, where CaCl_2 salt solution was either added before or after the sonication.	118

Figure 5.32	Total volume of lecithin cum salt in dispersion as a function of temperature for different molar ratios of lecithin to the CaCl_2 salt (fixed at 2.04 mM) in the dispersions. The concentrations of lecithin respectively are 1 mg/ml, 1.5 mg/ml, 2 mg/ml, 2.5 mg/ml and 3 mg/ml.	120
Figure 5.33	Total volume of lecithin cum salt in dispersion as a function of concentration of lecithin for dispersions with and without the addition of CaCl_2 salt solution at 25 °C. Note that a fixed amount of CaCl_2 salt solution (2.04 mM) was added to the lecithin dispersions with different concentrations of lecithin varying from 1 mg/ml to 3 mg/ml.	121
Figure 5.34	Total volume of lecithin cum salt in dispersion as a function of concentration of lecithin for dispersions with and without the addition of CaCl_2 salt solution at 50 °C. Note that a fixed amount of CaCl_2 salt solution (2.04 mM) was added to the lecithin dispersions with different concentrations of lecithin varying from 1 mg/ml to 3 mg/ml.	122
Figure 5.35	Total volume of lecithin cum salt in dispersion as a function of temperature for lecithin dispersions with the addition of NaCl salt solution. Ratio indicates the molar ratio of lecithin (fixed at 1 mg/ml) to the NaCl salt in the dispersion.	125
Figure 5.36	Total volume of lecithin cum salt in dispersion as a function of temperature for lecithin dispersions with the addition of NaCl salt solution. Ratio indicates the molar ratio of lecithin (fixed at 2 mg/ml) to the NaCl salt in the dispersion.	126
Figure 5.37	Total volume of lecithin cum salt in dispersion as a function of concentration of NaCl salt solution in lecithin dispersions with concentration of 1 mg/ml at 25 °C and 50 °C.	127
Figure 5.38	Total volume of lecithin cum salt in dispersion as a function of concentration of NaCl salt solution in lecithin dispersions with concentration of 2 mg/ml at 25 °C and 50 °C.	128
Figure 5.39	Schematic representation of a simple structure of lecithin molecules arranged in the liposomes in the dispersion.	132
Figure 5.40	Schematic representations of the interaction of Ca^{2+} ion with lecithin molecules arranged in the liposomes in the dispersion. The solid line between the Ca^{2+} ion and the phosphate group in the lecithin molecule represents a strong interaction.	134
Figure 5.41	Schematic representations of the interaction of Na^+ ion with lecithin molecules arranged in the liposomes in the dispersion. The solid line between the Na^+ ion and the phosphate group in the lecithin molecule represents a strong interaction.	135

LIST OF PUBLICATIONS

Yeap, P.K., Lim, K.O., Chong, C.S., Teng, T.T. and Mohamed, A.R. (2006) Density Studies of Lecithin-Water Dispersions. (Paper Presented in Persidangan Fizik Kebangsaan 2006 (PERFIK 2006), 6 and 7 December 2006, Malaysia)

Yeap, P.K., Lim, K.O., Chong, C.S., Teng, T.T. and Mohamed, A.R. (2007) Determination of Density of Lecithin and Its Effective Molecular Volume in Lecithin-Water Dispersions. (Paper Submitted)

Yeap, P.K., Lim, K.O., Chong, C.S., Teng, T.T. and Mohamed, A.R. (2007) Effect of Calcium Ions on the Density of Lecithin and Its Effective Molecular Volume in Lecithin-Water Dispersions. (Paper Submitted)

LIST OF TABLES

		Page
Table 4.1	Densities of air and water at temperatures from 25 °C to 55 °C.	57
Table 5.1	Effect of time of sonication on the size distribution of the liposomes generated in the dispersions.	63
Table 5.2	Size estimation of the liposomes generated in dispersions with different concentrations of lecithin.	68
Table 5.3	Size estimation of the liposomes generated in lecithin dispersions with the addition of CaCl ₂ salt solution.	69
Table 5.4	Size estimation of the liposomes generated in different concentrations of lecithin in the dispersions with the addition of a fixed amount of CaCl ₂ salt solution.	70
Table 5.5	Size estimation of the liposomes generated in lecithin dispersions with the addition of NaCl salt solution.	70
Table 5.6	Densities of lecithin dispersions at different temperatures.	71
Table 5.7	Experimental density data of CaCl ₂ salt solution at temperatures from 25 °C to 55 °C.	87
Table 5.8	Experimental density data of NaCl salt solution at temperatures from 25 °C to 55 °C.	87
Table 5.9	Experimental density data of CaCl ₂ salt solution at 25 °C.	88
Table 5.10	Experimental density data of NaCl salt solution at 25 °C.	88
Table 5.11	Effective molecular volume of lecithin in dispersions with different concentrations of lecithin.	110
Table 5.12	Densities of sonicated lecithin at 25 °C and 50 °C.	111
Table 5.13	Effective molecular volume of lecithin generated in different concentrations of lecithin in the dispersions with the addition of a fixed amount of CaCl ₂ salt solution.	124
Table 5.14	Densities of sonicated lecithin generated in different concentrations of lecithin in the dispersions with the addition of a fixed amount of CaCl ₂ salt solution at 25 °C and 50 °C.	124
Table 5.15	Effective molecular volume of lecithin generated in two concentrations of lecithin in the dispersions with the addition of a fixed amount of NaCl salt solution.	130

Table 5.16	Densities of sonicated lecithin generated in two concentrations of lecithin in the dispersions with the addition of a fixed amount of NaCl salt solution at 25 °C and 50 °C.	130
------------	--	-----

PENYELIDIKAN VOLUMETRIK SISTEM PENYEBARAN LESITIN-AIR

ABSTRAK

Kajian volumetrik mengenai sistem penyebaran lesitin-air telah dijalankan. Satu tinjauan literatur mengenai liposom dan kegunaannya dalam beberapa bidang sains dan perubatan telah diperincikan untuk menjelas kepentingan pengajian liposom. Objektif utama bagi penyelidikan ini adalah untuk menentukan secara jitu, ketumpatan sistem penyebaran lesitin dan ketumpatan lesitin dalam sistem penyebaran, serta mengkaji susunan struktur molekul lesitin dalam liposom bagi sistem penyebaran lesitin itu. Untuk mencapai tujuan ini, saiz liposom telah dianggar melalui ukuran kekeruhan, sementara ketumpatan sistem penyebaran lesitin telah ditentukan dengan tepat pada julat suhu antara 25 °C ke 55 °C dengan menggunakan satu meter ketumpatan berdigit. Kajian yang selanjutnya ke atas kesan kehadiran ion juga disiasat. Anggaran saiz liposom bagi sistem penyebaran lesitin yang berbeza menyokong pemerhatian yang menyatakan bahawa tempoh sonikasi yang berpanjangan biasanya akan menghasilkan liposom unilamela kecil. Ketumpatan lesitin dalam sistem penyebaran dihitung dan nilainya didapati setanding dengan nilainya dalam keadaan kering (1.056 g cm⁻³). Namun begitu, nilai itu didapati adalah tinggi sedikit untuk sistem penyebaran yang mempunyai kepekatan lesitin yang lebih tinggi. Pemerhatian ini telah disahkan selanjutnya dengan nilai anggaran untuk isipadu molekul berkesan lesitin, di mana nilai itu adalah lebih kecil bagi sistem penyebaran yang mempunyai kepekatan lesitin yang lebih tinggi. Kajian sandaran ketumpatan dengan suhu menunjukkan kehadiran satu peralihan fasa termotropik pada kira-kira 40 °C hingga 45 °C. Dengan penambahan ion Ca²⁺ atau ion Na⁺ dalam sistem penyebaran lesitin, ketumpatan sistem penyebaran lesitin dan juga ketumpatan lesitin dalam sistem penyebaran meningkat. Akan tetapi, isipadu molekul berkesan lesitin dalam sistem penyebaran menurun. Kesan itu adalah

lebih ketara dengan penambahan ion Ca^{2+} berbanding dengan penambahan ion Na^+ . Dengan sedemikian, boleh dinyatakan bahawa ion Ca^{2+} akan menyusun molekul lesitin dalam sistem penyebaran dengan lebih padat berbanding dengan ion Na^+ .

VOLUMETRIC STUDIES OF LECITHIN-WATER DISPERSIONS

ABSTRACT

Volumetric studies of lecithin-water dispersions were carried out. A literature review of liposomes and their applications in various areas of science and medicine was presented to illustrate the importance of research studies on liposomes. The main objectives of this present study are to determine accurately the density of the lecithin dispersions and the density of the lecithin in the dispersions, as well as to elucidate the molecular packing structure of the liposomes in the lecithin dispersions. To achieve this aim, sizes of liposomes were estimated via turbidity measurements, while the density of the lecithin dispersions were determined accurately over a temperature range from 25 °C to 55 °C using a digital density meter. Further studies on the effects of ions were similarly investigated. The estimation of the liposome sizes in different lecithin dispersions supported the observation that prolonged sonication typically produced small unilamellar liposomes. The density of the lecithin in the dispersions was calculated and the value was found to be comparable to the value in the dry state (1.056 g cm⁻³). Nevertheless, the value was found to be slightly higher for dispersions with higher concentrations of lecithin. This observation was further confirmed by the calculated values of the effective molecular volume of lecithin, which were smaller for higher concentrations of lecithin in the dispersions. Temperature dependence studies of density demonstrated the presence of a thermotropic phase transition at about 40 °C to 45 °C. With the addition of Ca²⁺ ions or Na⁺ ions to the lecithin dispersions, the density of the lecithin dispersions and the density of the lecithin in the dispersions increased. However, the effective molecular volume of lecithin in the dispersions decreased. The above effects were more pronounced with the addition of Ca²⁺ ions

compared to the addition of Na^+ ions, thus probably indicating that Ca^{2+} ions pack the lecithin molecules in the dispersions even tighter when compared to that of Na^+ ions.

CHAPTER 1

GENERAL INTRODUCTION

1.1 Introduction

Cells are the basic structural and functional units of all living organisms (Widmaier et al., 2004). The human body is composed of trillions of cells. There are two classes of cells, eukaryotic cells and prokaryotic cells. The cells of the human body, as well as those of multicellular animals and plants, are eukaryotic cells. These cells consist of a nuclear membrane surrounding the cell nucleus and numerous other membrane-bound structures. Prokaryotic cells, for example, bacteria, lack these membranous structures (Figure 1.1).

Cells are surrounded by a plasma membrane, which covers the cell surface. Within each eukaryotic cell are numerous membrane-bound compartments, particles and filaments, known as cell organelles (Figure 1.1). Each cell organelle performs specific functions that contribute to the cell's survival.

The interior of a cell is divided into two regions, the nucleus and the cytoplasm (Figure 1.2). The cytoplasm contains two components, cell organelles and the cytosol. The term intracellular fluid refers to all the fluid inside a cell, which includes the cytosol plus the fluid inside all the organelles and also the nucleus. The chemical compositions of the fluids in the cell organelles may differ from that of the cytosol.

As mentioned earlier, all living cells are enclosed by a plasma membrane. Membranes form a major structural element in cells. Membranes serve not only as a sturdy envelope inside which the cell can function, but also as a discriminating portal.

Bacteria and archaeobacteria are prokaryotes. All other organisms are eukaryotes.

A A Prokaryotic cell does not have internal organelles surrounded by a membrane. Most of a prokaryote's metabolic functions take place in the cytoplasm.

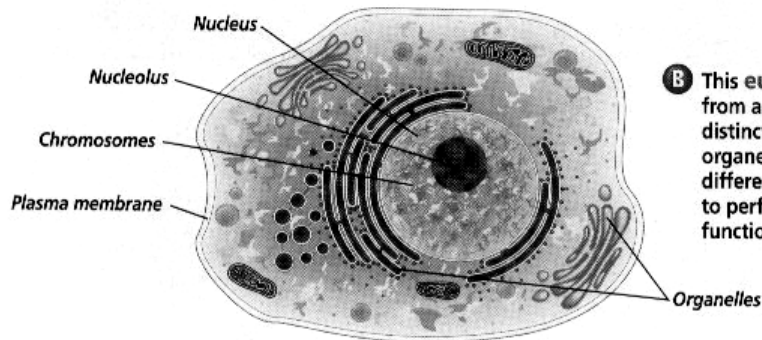
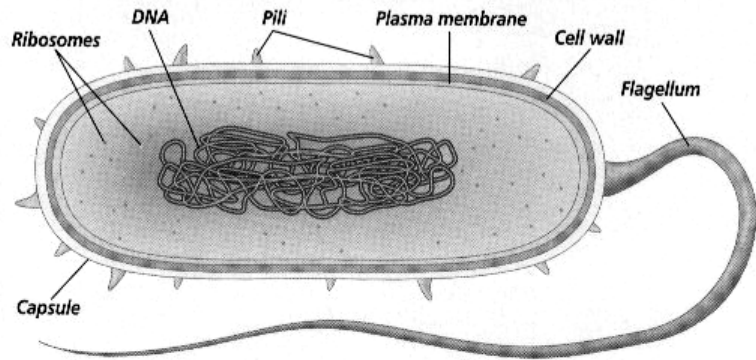

B This eukaryotic cell from an animal has distinct membrane-bound organelles that allow different parts of the cell to perform different functions.

Figure 1.1 Comparison of eukaryotic cell and prokaryotic cell.

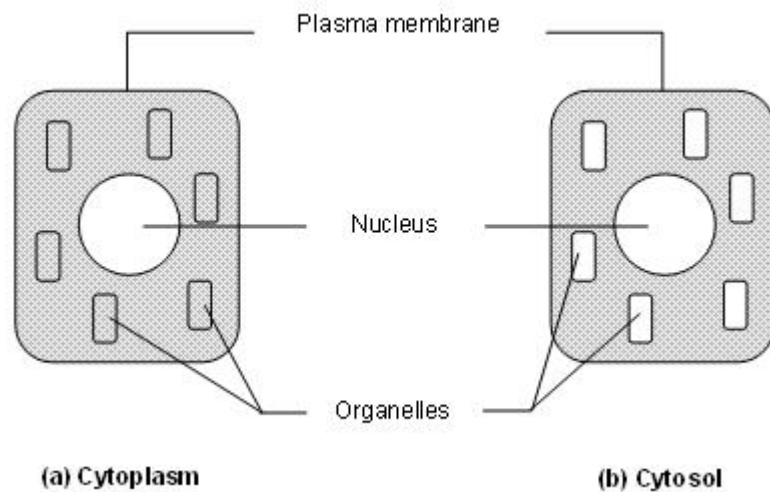

Figure 1.2 Comparison of cytoplasm and cytosol. (a) Cytoplasm (colored area) is the region of the cell outside the nucleus. (b) Cytosol (colored area) is the fluid surrounding the cell organelles.

They act as a selective barrier to the passage of molecules, allowing some molecules to cross while excluding others. The plasma membrane regulates the passage of substances into and out of the cell, whereas the membranes surrounding cell organelles regulate the movements of substances between the organelles and the cytosol.

The structure, function and chemistry of the membranes are highly significant in biological systems. The passive and active transport functions involve the membranes. Membranes play an important role in excitability phenomena and signal transmissions. They also provide the ordered structures for enzymatic, hormonal and drug activities. The elucidation of membrane structure, the organization of the component macromolecules and the studies of their dynamical behavior, have been subjects of much additional research for the past few decades.

Membranes are composed almost entirely of two classes of molecules, proteins and lipids. The proteins serve as enzymes or biological catalysts, and provide the membrane with their distinctive functional properties. The lipids, however, provide the gross structural properties of the membrane. Several models have been proposed to represent the geometrical arrangement of these two classes of molecules in the biological membrane. In 1925, Gorter and Grendel reported that lipids extracted from erythrocyte membranes spread as a monolayer at an air-water interface (Harrison and Lunt, 1975). Apparently independently, Danielli and Davson in 1935 proposed that the lipid matrix of natural membranes was sandwiched between two layers of protein. The widespread occurrence of such apparently similar membrane structures led Robertson to promote the concept of a universal unit membrane based on the Davson-Danielli model. In the Davson-Danielli-Robertson bilayer leaflet model (Figure 1.3), the protein molecules in either globular or extended form are spread over both surfaces of a continuous lipid bilayer. As more was learned about the interactions between lipids

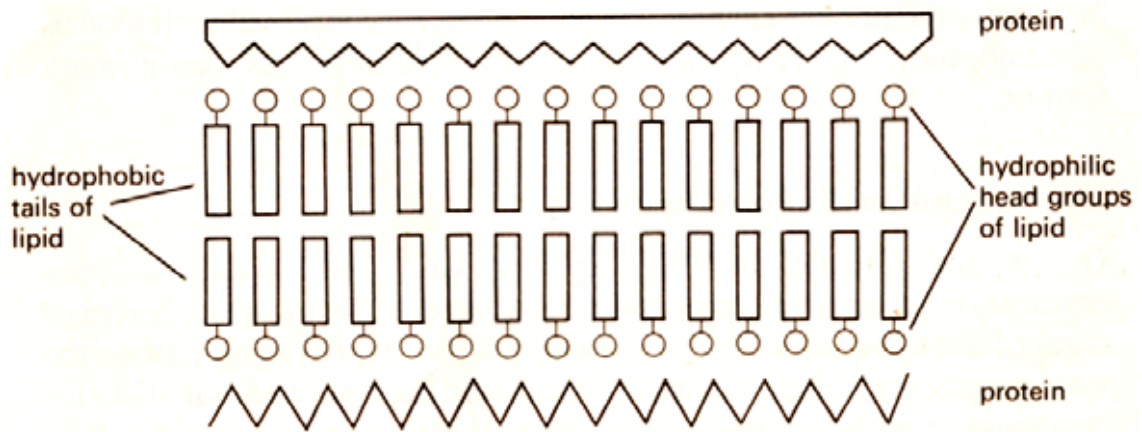

Figure 1.3 Schematic representations of the Davson-Danielli-Robertson model (adapted from Harrison and Lunt, 1975).

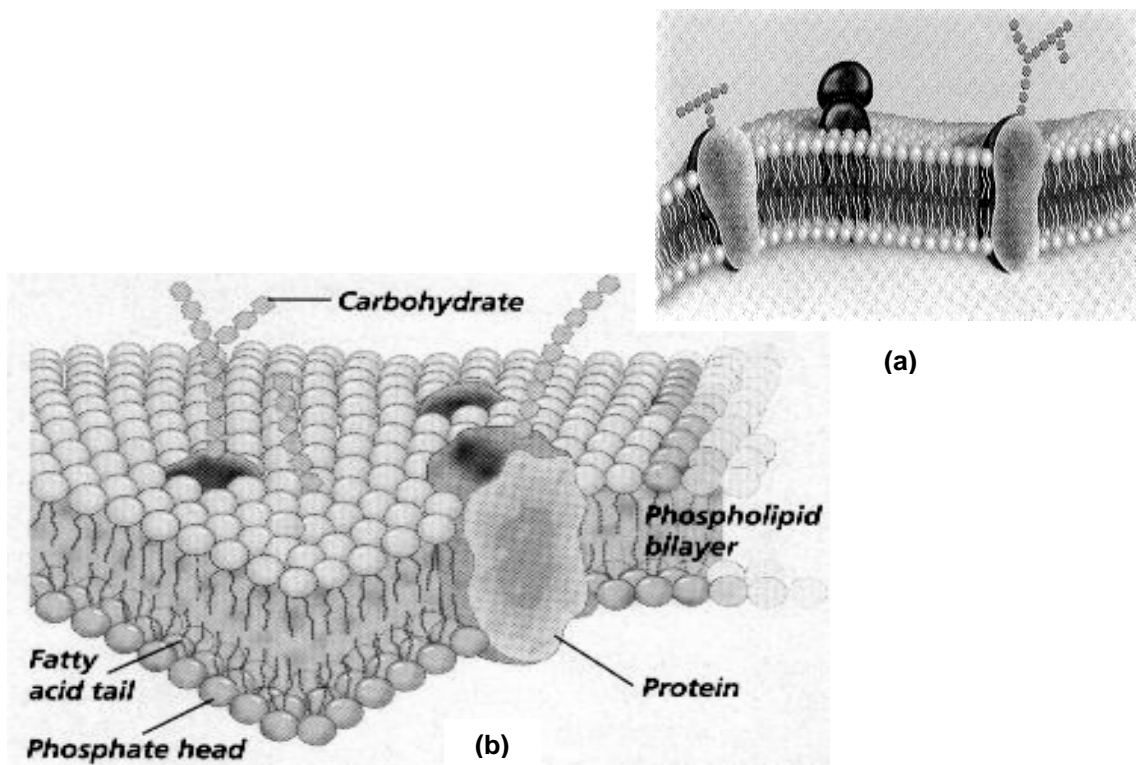

Figure 1.4 Schematic representation of the fluid mosaic model of membrane structure. (a) Cross-sectional view. The phospholipids are arranged in a discontinuous bilayer. (b) Three-dimensional view. The globular proteins are partially embedded in a phospholipid bilayer (adapted from Singer and Nicolson, 1972).

and proteins in membranes, it became evident that lipids and proteins jointly form the membrane continuum (Singer, 1971). The membrane model, so called the fluid mosaic model, which was amplified by Singer and Nicolson (1972), has wide acceptance at the present time. In this model (Figure 1.4), membrane proteins float in a sea of lipid (phospholipid) bilayer.

There are two classes of membrane proteins, integral and peripheral. Integral proteins are amphipathic, having polar amino acid side chains in one region of the molecule and nonpolar side chains clustered together in a separate region. They are arranged in the membrane with the same orientation as lipids, the polar regions are at the surfaces in association with polar water molecules, and the nonpolar regions are in the interior in association with nonpolar fatty acid chains. They have thus predominantly hydrophobic interaction with the lipids. Peripheral proteins, on the other hand, are not amphipathic. They do not associate with the nonpolar regions of the lipids in the interior of the membrane. They are held at the membrane surface by predominantly electrostatic interactions, where they are bound weakly to the polar regions of the integral proteins (Figure 1.5).

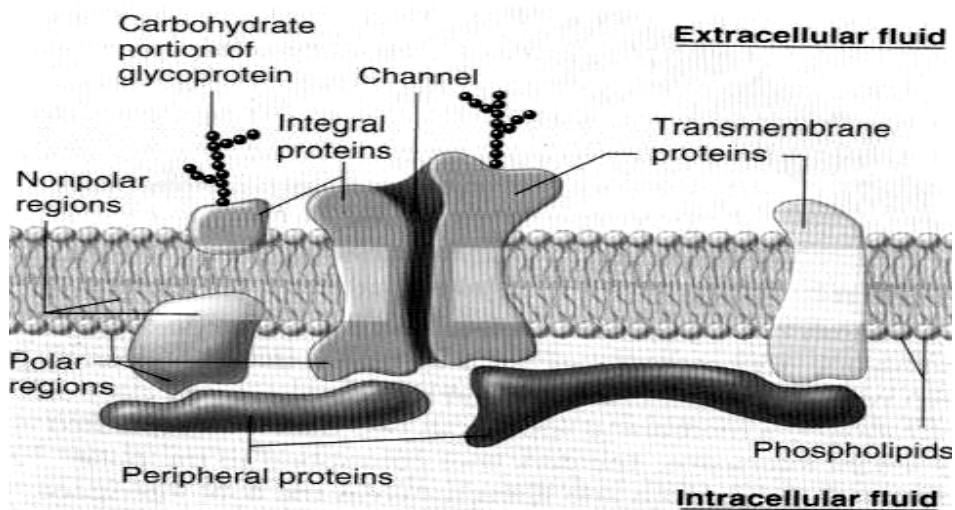

Figure 1.5 Arrangement of integral and peripheral membrane proteins in association with a lipid (phospholipid) bilayer (adapted from Widmaier et al., 2004).

This thesis is concerned with studying the model membrane system, which is formed by lipids without any protein. Since lipids form the structural skeleton of biological membranes, it is necessary to develop a detailed understanding of the physical properties and functional roles of model membrane systems made from lipids. The lipids found in membranes are of amphipathic character, which consist of both a polar or hydrophilic (water loving) head group region and a nonpolar or hydrophobic (water hating) region. In most membrane lipids, the nonpolar or hydrophobic region consists of hydrocarbon chains of fatty acids, with a carboxyl group (-COOH) at one end. In a typical membrane lipid, two fatty acid molecules are chemically bonded through their carboxyl ends to a backbone of glycerol, while the glycerol backbone in turn, is attached to a polar or hydrophilic head group consisting of either phosphate or other groups, which often carry an ionic charge. Phosphate-containing amphipathic lipids are known as phospholipids (Figure 1.6).

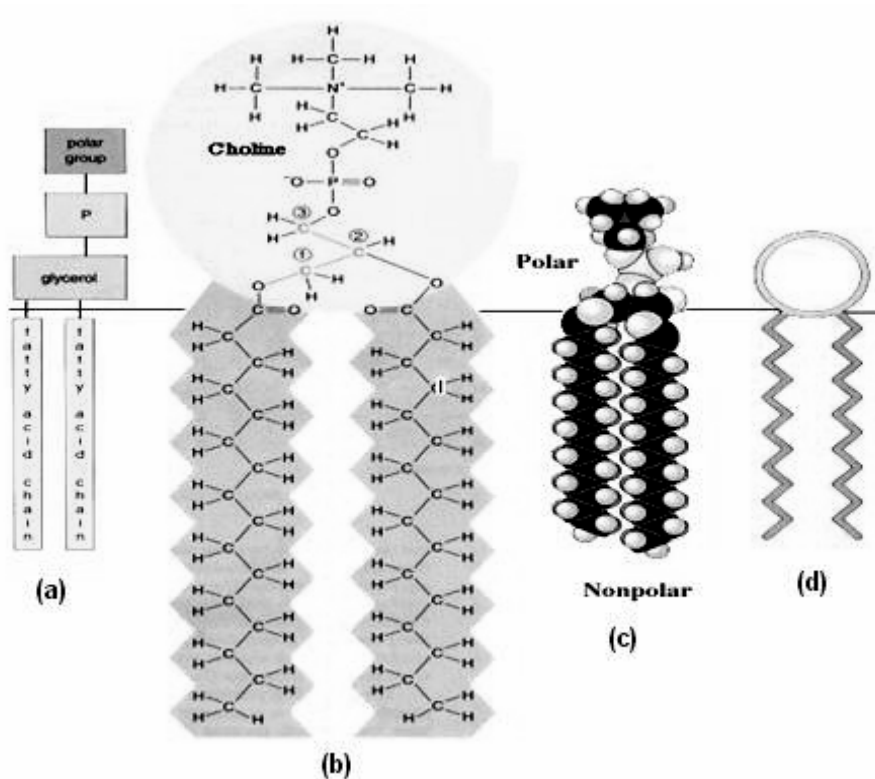

Figure 1.6 Glycerol and fatty acids are the major subunits that combine to form phospholipids. (a) Arrangement of subunits in phospholipids. (b) Structure and formula for a common membrane phospholipid, phosphatidylcholine. (c) Space-filling model of phosphatidylcholine. (d) Diagram used to depict a phospholipid molecule.

The major membrane lipids are phospholipids. They are amphipathic molecules, one end constitutes a charged region, whereas the fatty acid chains provide a nonpolar region at the opposite end. Additional small molecules can be linked to the phosphate group to form a variety of phospholipids, including phosphatidylcholine, phosphatidylethanolamine, phosphatidylserine, phosphatidylinositol and cardiolipin. As mentioned earlier, the phospholipids in cell membranes are organized into a bimolecular layer (bilayer) with the nonpolar of fatty acid chains in the middle, while the polar regions of the phospholipids are attracted to the polar water molecules in the extracellular fluid and cytosol, and oriented toward the surfaces of the membrane (Figure 1.7).

Numerous model membrane systems have been developed for studying the structure-function relationships exhibited by biological membranes. The study of the properties of lipids as model membrane systems has been rationalized as a shortcut approach necessitated by the complexity of biological membranes. The three major frequently used model membrane systems are monolayers, bilayers and vesicles (liposomes) (Figure 1.8).

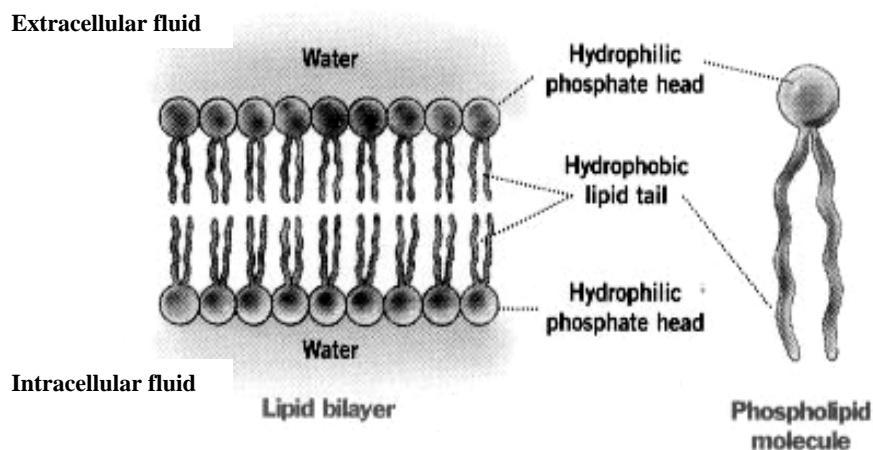
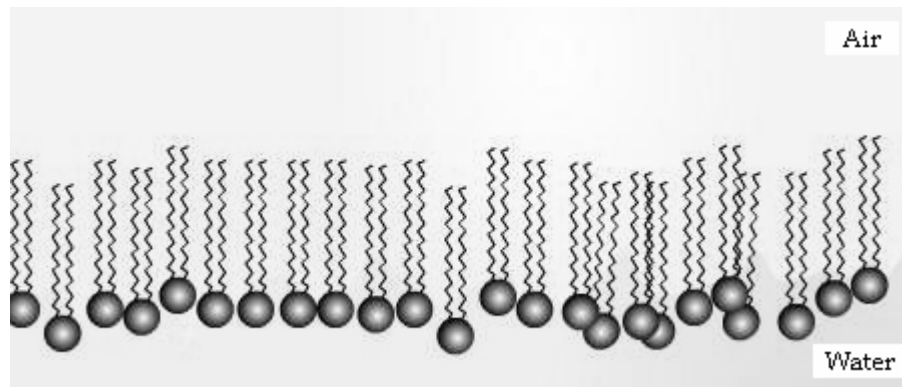
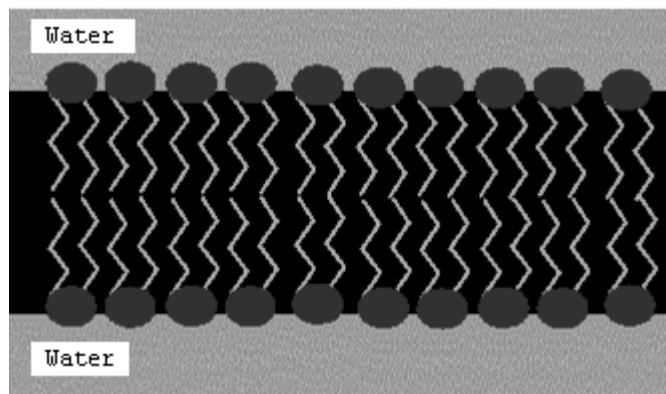

Figure 1.7 Bilayer arrangement of phospholipids.



(a)



(b)

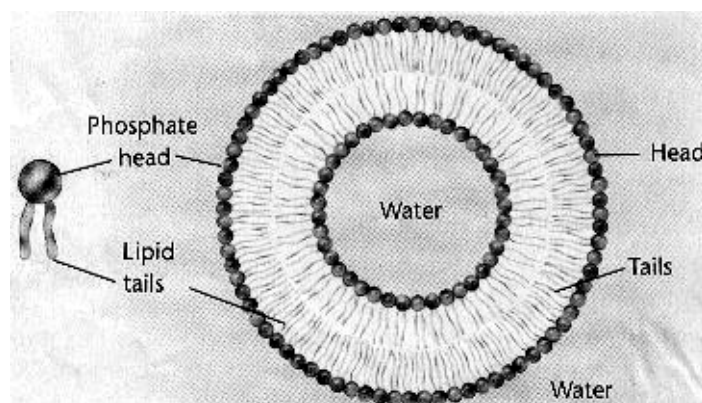

(c)

Figure 1.8 Three of the most frequently used model membrane systems. (a) Monolayers at the air-water interface. (b) Bilayers. (c) Vesicles or liposomes.

The monolayer at the air-water interface is a system in which the hydrophilic parts of the lipids are submerged in the water phase, while the hydrophobic parts remain outside pointing into the air to form an insoluble monolayer. Although the monolayer system is limited in terms of applicability to transport phenomena, it provides extremely useful information on molecular packing and interactions at an interface. The characteristics of such a system are usually described by experimentally measured properties, such as surface pressure, surface potential and surface viscosity (Blaudez et al., 1999; Brzozowska and Figaszewski, 2002).

The bilayer systems, also known as black lipid membranes, are favorite model systems for studying the electrical properties of lipid bilayers (Tanaka and Yonezawa, 1997; Winterhalter, 2000). Typically, the black lipid membranes are formed by dissolving lipids in a hydrocarbon solvent and applying them across a small aperture that separates two electrically-insulated compartments. The solvent tends to collect at the perimeter of the aperture, leaving an optically black bilayer membrane across the center. The electrical properties of the barrier are then measured employing electrodes in the two buffered compartments (Figure 1.9).

The model membrane vesicles or liposomes are self-enclosed spherical or oval structures, composed of the lipid bilayers encapsulating an inner solution phase (Bangham et al., 1965). Liposomes possess unique properties owing to the amphipathic character of the lipids. Liposomes are of major interest as model membrane systems due to their vast potential applications in biological, medical, pharmaceutical and chemical fields. The following section is a brief discussion on liposomes so as to provide some background and rationale for the studies to be reported in this thesis. Further details would be highlighted in Chapter 2.

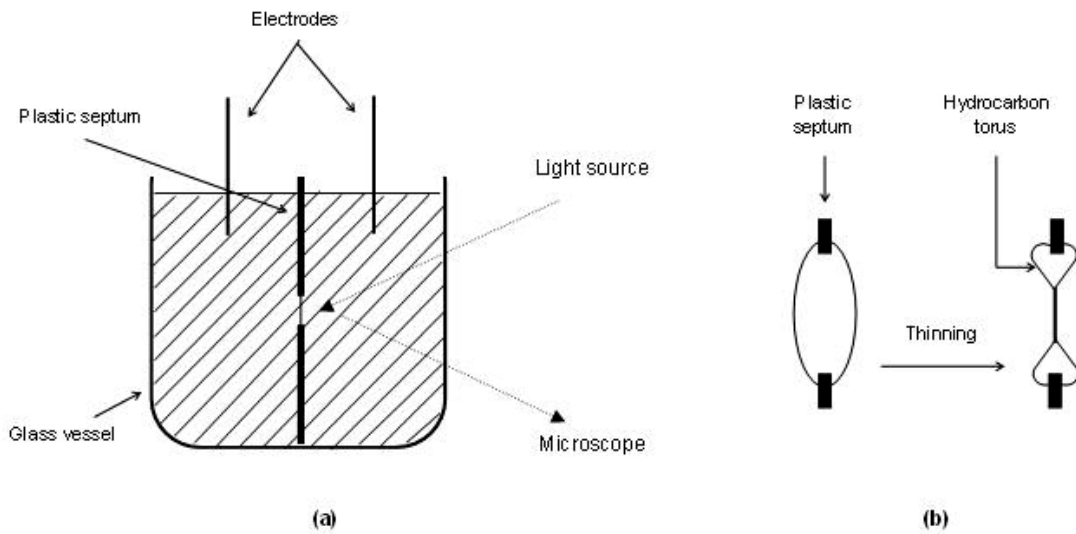

Figure 1.9 Schematic representation of the study of black lipid membranes. (a) Simple experimental design showing a plastic septum with an aperture in the centre. The bilayer membrane covers the aperture and separates the two aqueous phases. (b) The black lipid membrane is prepared by applying membrane-forming solution across the aperture in the plastic septum. After thinning over a period of about 15 min, the final bilayer membrane can be observed as the hydrocarbon torus held on at the edge of the aperture. It appears black in reflected light.

1.2 Studies on Liposomes

Liposomes are quasi-spherical structures composed of lipid bilayers that encapsulate an aqueous space (Bangham et al., 1965). Liposomes form spontaneously when lipids are dispersed in an aqueous media, giving rise to a population of liposomes with various sizes. They can be prepared in the laboratory by various methods, such as organic solvent injection, sonication or extrusion, all of which are reviewed in Section 2.3 in Chapter 2.

The study of liposomes is very essential because of their similarity to biological membranes and their medical value as delivery agents for enzymes, drugs, and in genetic manipulation and diagnostic imaging (Papahadjopoulos, 1978; Philippot and Schuber, 1995). Nowadays, liposomes are not only commonly used as model

membrane systems. Their use as drug delivery system in pharmaceutical industry however, has a gradual, progressive application (Lasic and Papahadjopoulos, 1998). Because of their vast applications, liposomes are of particular interest.

In the present study, model membrane system used was a sonicated dispersion of lipid in water. It was observed by Bangham and Horne (1964) from electron micrographs that multilamellar liposomes were formed in the dispersions (Figure 1.10).

Liposomes can be manufactured from a variety of lipids and lipid mixtures. Phospholipids are most commonly used. The phospholipid used in this study is dipalmitoyl lecithin, also known as dipalmitoyl phosphatidylcholine (DPPC). The choice was mainly based on the fact that a substantial fraction of phospholipids in cell membranes is phosphatidylcholine (PC). Phosphatidylcholines are often used as the principal phospholipid in liposomes for a wide range of applications because of their neutral charge and chemical inertness. Dipalmitoyl lecithin has a 16:0 hydrocarbon

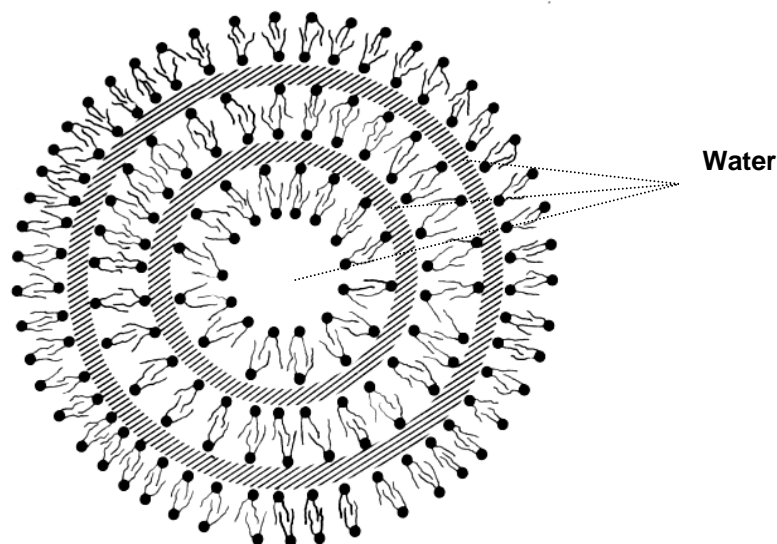

Figure 1.10 Multilamellar liposomes dispersed in excess water.

chain. In other words, it has a chain length consisting of 16 carbon atoms and without double bonds. Further, dipalmitoyl lecithin has a characteristic thermotropic phase transition at a convenient temperature of 41 °C in excess water (Chapman et al., 1967).

Various investigations have addressed the biological aspects of liposomes, both in vivo and in vitro. The relationship between the structure of the simple lipid membrane and that of the lipid phase of biological membranes has been a matter of some concern. As is well known, the polymorphism of the bilayer arises from alterations in the packing arrangements of lipid hydrocarbon chains, order or disorder isomerizations in intramolecules, and hydrophobic or hydrophilic interactions between water and lipid. Consequently, considerable interest underlying the subject of the molecular packing structure of liposomes in lipid-water systems has been generated.

The size or radius of curvature of liposomes is an important parameter that determines their physical properties. In addition, the liposome radius of curvature is known to significantly affect the physicochemical properties of lipid bilayers. In pharmaceutical applications, drug encapsulation efficiency and in vivo behavior are highly dependent on liposome size. Uchiyama et al. (1995) previously investigated liposomes as drug carriers for delivery to tumor. They indicated that the accumulation of liposomes into the tumor was primarily governed by their size. Later, the size of liposomes has been concluded to be an important factor in the efficient delivery of an antitumor agent to a tumor by Nagayasu et al. (1999). It has been further shown that the size of liposomes influences the dermal delivery of substances into the human skin (Sentjurc et al., 1999; Verma et al., 2003). Henceforth, the determination and control of liposome size are critically essential.

The occurrence of a thermotropic phase transition is characteristic of lipid-water systems. The study of thermotropic lipid phase transitions in both natural and model

membranes has proven to be a productive approach towards the understanding of the structure, organization and interactions present in lipid bilayer assemblies. The phase behavior of lipid bilayers and their structural relationship to biological membranes have motivated scientists from many disciplines to study their unique properties. For example, fundamental studies of temperature and pressure dependence (Yi and MacDonald, 1973; Spiker and Levin, 1976; Asher and Levin, 1977; Utoh and Takemura, 1986) that induced structural changes in biological membrane organizations, have provided the background needed for better understanding of how the ordering and disordering mechanisms vary at the respective transition points, as well as for comparing the results obtained on more complex biological membrane systems.

Knowledge of how lipids arrange or pack in liposomes with other molecules, such as cholesterol (Ladbrooke et al., 1968; Hinz and Sturtevant, 1972a), proteins (Massari and Colonna, 1986; Trivedi et al., 2000) and ions (Verkleij et al., 1979; Blatt and Vaz, 1986), are essential in understanding the arrangement of lipids in biological membranes and their interaction with other biomolecules.

Ions are known to greatly influence many physiological and biochemical processes. At the cell membrane level, the ions can significantly influence the conformation of proteins inserted or attached to the lipid bilayer, the packing of the lipids present in the membrane, the structure of the water in contact with the membrane and the interactions between membranes (Cunningham et al., 1986).

The binding of ions (cations or anions) to liposomes plays a conspicuous role in determining the physical properties and functions of biological membranes. Information on binding sites and the mechanism and strength of binding are therefore of great importance. Recent studies suggest that perturbations of thermotropic lipid phase transitions using ions may be biologically significant. However, the behavior observed

experimentally of the effects of ions on the transition temperatures in lipid-water systems is apparently rather complex.

1.3 Objectives and Scope of Present Work

The main objectives of this study are

- to determine the density of the lipid-water dispersions and subsequently the density of the lipid in the dispersions¹
- to elucidate the molecular packing structure of the liposomes through accurate density measurements of the lipid-water dispersions, both with and without addition of ions.

The lipid-water dispersions are to be prepared by means of sonication to produce liposomes of minute sizes. Measurements of the turbidity as a function of wavelength, range from 400 nm to 800 nm, using a spectrophotometer, will provide a means of evaluating the average size of the liposomes in the dispersions. The sizes of the liposomes formed in the dispersions are generally within the range of 80 nm to 170 nm.

Most of the work in this study will focus on the methodology of density measurements. The densities of the lipid-water dispersions will be measured using a digital density meter. The densities will be measured in the temperature range from 25 °C to 55 °C, within the specific thermotropic transition points of the lipid used.

A theoretical approach, based on the precise density measurements, will be formulated to estimate the effective volume of lipid molecules packed in the liposomes

¹ The density of the lipid-water dispersion is the density for the whole dispersion, while the density of the lipid in the dispersion refers only to the density of the lipid itself in the dispersion.

in the dispersions. The changes of the effective molecular volume, which are relatively dependent upon the measured densities, will indirectly serve as a study on the structural changes of the liposomes in the dispersions. The thermotropic phase transition will also be observed by means of density measurements.

In order to reach a general understanding of the factors determining molecular packing structure of the liposomes in the lipid-water dispersions, it is necessary to extend the above considerations to take into account the effects of ions. Ions to be used in this study are calcium (Ca^{2+}) and sodium (Na^+) ions, which are divalent and monovalent cations, respectively. Further studies on the ions effects via density and turbidity measurements will similarly be investigated. Changes of density result in changes of effective molecular volume. The molecular packing structure of the liposomes with the addition of ions is therefore, expected to vary. The study of thermotropic phase transition of the lipid-water dispersions, with addition of ions, will also be reported.

1.4 Organization of Thesis

The thesis is broadly organized into six chapters. The first chapter is the introductory chapter that consists of a very general background on the organizations in both natural and model membrane systems, a brief review of liposomes, as well as the objectives and scope of this present study. Chapter 2 covers a basic information of liposomes and a more comprehensive review of the literature on liposomes. This includes studies on the method of preparation, applications, phase transitions, size and density determinations, as well as effects of ions. Chapter 3 outlines the theoretical considerations that may be adapted for the study of the molecular packing of liposomes. Appropriate equations are developed to relate density and other measurable quantities, such as mass and volume. A detailed description of the experimental works, including

materials and methods used, is given in Chapter 4. This covers the preparation of samples and the measurements of turbidity and density. The results of the measurements and calculations are summarized in Chapter 5. This chapter also provides a qualitative discussion on the results obtained. Finally, Chapter 6 reports the summary and conclusions of this present study and proposes some recommendations for future work.

CHAPTER 2

LIPOSOMES (LIPID VESICLES)

2.1 Introduction

During the past few decades, liposomes have been a subject of interest for many investigators because of their potential applications as drug delivery systems in the areas of diagnosis, catalysis, immuno-modulation as well as genetic engineering (Lasic and Papahadjopoulos, 1998). The study of liposomes as model systems for biological membranes has contributed greatly to many aspects of cell physiology, such as permeability, fusion and membrane-bound enzyme properties. In the preceding chapter, some very general information were given on their organizations in both natural and model membrane systems. In this chapter, special emphasis is given to a review of the literature on model membrane liposomes.

This chapter is organized into eight parts. In Section 2.2, a brief review is given on the structure of the liposomes. In Section 2.3, the method of preparation and studies that deal with sonication are discussed. In Section 2.4, a further review on the applications of the liposomes is presented. The study of polymorphism and thermotropic phase transitions of lipid-water systems is reviewed in the section following. A summary of literature reviews on the size and density determinations of the liposomes in lipid-water systems is presented in Sections 2.6 and 2.7, respectively. A further detailed discussion with emphasis on the effects of ions to the lipid-water systems is reviewed in the concluding section of this chapter.

2.2 Structure of Liposomes

Liposomes or lipid vesicles (Figure 2.1), are colloidal structures formed by the self-assembly of amphipathic lipid molecules in solution (Bangham et al., 1965). When mixed with water under certain physical conditions, these lipid molecules spontaneously form lipid bilayers in which the hydrophilic head groups remain in contact with the aqueous environment, while the hydrophobic tails point inward to form the inner portion of the bilayers. Apart from their chemical constituents, which determine such properties as membrane fluidity, charge density and permeability, liposomes are characterized by their size and the number of bilayers.

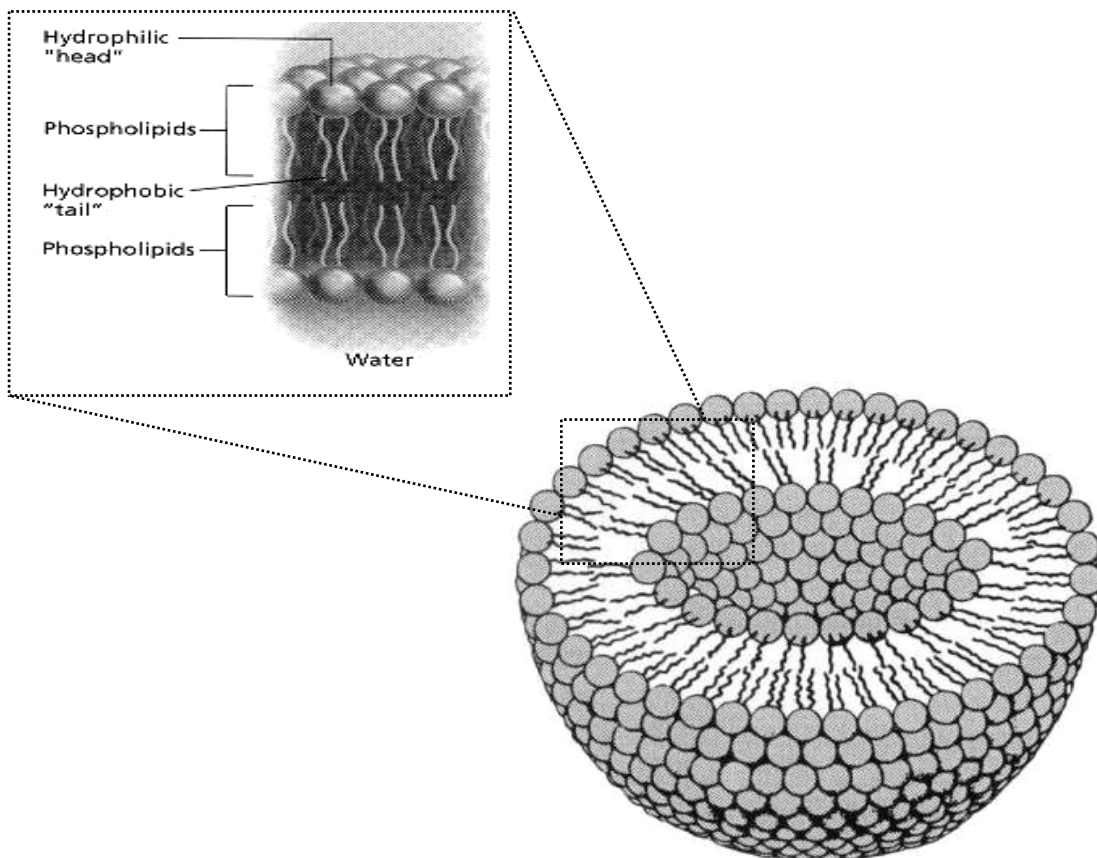

Figure 2.1 Structure of liposome formed by phospholipids. Note that the central region consists of polar head groups of the inner and bottom surfaces and not a solid mass of polar head groups.

The nomenclature for liposomes, which was approved upon at the New York Academy of Sciences meeting on “Liposomes and Their Uses in Biology and Medicine”, has been widely accepted at the present time (Papahadjopoulos, 1978). In this nomenclature, liposomes are categorized as multilamellar vesicles (MLVs), small unilamellar vesicles (SUVs) and large unilamellar vesicles (LUVs). MLVs generally consist of a population of vesicles covering a wide range of sizes, from 100 nm to 1000 nm, each vesicle usually consisting of five or more concentric lamellae. On the contrary, unilamellar vesicles are divided into two classes; vesicles under 100 nm are considered as SUVs, while vesicles larger than that are classified as LUVs.

2.3 Preparation of Liposomes

2.3.1 Multilamellar Liposomes (MLVs)

Numerous methods have been employed for the preparation and production of multilamellar and unilamellar liposomes (New, 1990; Betageri et al., 1993). Preparation of the simplest model system involves the straightforward hydration of a lipid film by mechanical agitation. The hydration followed by the agitation result in the generation of MLVs (Bangham et al., 1965), which have been used for many years as model systems for the bilayer matrix of biological membranes. However, their use is restricted to physical studies on bilayer organization and the motional properties of individual lipids within a membrane structure. One of the major drawbacks of this thin-film hydration method is the poor encapsulation efficiency of water-soluble drugs.

MLVs with relatively high encapsulation efficiencies can be produced by hydrating the lipid in the presence of an organic solvent. Papahadjopoulos and Watkins (1967) previously developed this method that begins with a two-phase system consisting of equal volumes of petroleum ether containing a mixture of lipids and an

aqueous phase. The phases are then emulsified by vigorous vortexing and the ether phase is removed by passing a stream of nitrogen gas over the emulsion. When the solvent is removed by the carrier gas, MLVs form in the aqueous phase.

2.3.2 Small Unilamellar Liposomes (SUVs)

SUVs can be produced from MLVs by subjecting the MLVs to ultrasonic irradiation or by passage through a French press. There are two methods of sonication, using either a probe sonicator (Huang, 1969) or a bath-type sonicator (Johnson et al., 1971). The probe sonicator is usually employed for suspensions that require high energy in a small volume of high concentrations of lipids, while the bath-type sonicator is more suitable for large volumes of dilute lipids, where it may not be necessary to reach the minimum size limit for liposomes. Both procedures of sonication may lead to formation of SUVs of about 25 nm in diameter. A more detailed discussion on sonication is given in Section 2.3.4.

SUVs can also be obtained by injecting the dispersions of MLVs through the small orifice of a French press under (generally) very high pressure (Barenholz et al., 1979; Hamilton et al., 1980). The heart of a French press is the pressure cell, which is manufactured in stainless steel to resist high pressure. A dispersion of MLVs is placed in the French press and extruded at pressures up to 20,000 p.s.i. or even 40,000 p.s.i. (i.e. pounds per square inch, where 100 p.s.i. is equivalent to approximately 6.9 atm or 7.0×10^5 Pa). One pass through the pressure cell produces a heterogeneous population of liposomes ranging from several micrometers in diameter to sizes of SUVs. Multiple extrusions (mostly four passes) result in a progressive decrease in the mean diameter of liposomes. The resulting liposomes are larger than sonicated SUVs, ranging in size from 30 nm to 80 nm, depending on the pressure used. Barenholz et al. (1979) previously adapted this method to produce homogeneous population of SUVs

by extrusion of MLVs at 20,000 p.s.i. The method is simple, reproducible and nondestructive. However, temperature control is difficult. The body of the pressure cell must be allowed to cool between extrusions or the temperature rise may lead to a damage of the lipids or drugs. The working volumes are relatively small, about 50 ml maximum.

An alternative method for producing SUVs that avoids both sonication and exposure to high pressure is the ethanol injection method described by Batzri and Korn (1973). SUVs form instantaneously when lipids dissolved in ethanol are rapidly injected into an excess of buffer solution. This procedure is simple, rapid and highly reproducible. However, the ethanol will remain in the liposome suspensions. This disadvantage is that some biologically active macromolecules tend to become inactive in the presence of even low amounts of ethanol.

Deamer and Bangham (1976) later developed another ideal method for SUVs production based upon a solvent evaporation method, which involves injection of an ether-lipid mixture directly into warm aqueous solution. Typically, the ether-lipid mixture is injected into an aqueous solution of the material to be encapsulated, at 55 °C to 65 °C or under reduced pressure. Vaporization of the ether leads to the formation of SUVs.

2.3.3 Large Unilamellar Liposomes (LUVs)

There are two common procedures for producing LUVs, one involving detergent dialysis, the other the formation of a water-in-oil emulsion. Procedures that involve detergents vary depending upon the type of detergent. However, the principle is the same. Briefly, lipids are first solubilized by the detergent of choice, such as cholate or octylglucoside. The detergent is then removed either rapidly by dilution or gel filtration,

or slowly by dialysis. When the detergent concentration decreases, the lipids adopt unilamellar vesicular structures. Milsmann et al. (1978) previously described a method based on a fast and controlled dialysis of sodium cholate from phosphatidylcholine-cholate mixed micelles. This procedure results in a homogeneous population of LUVs, with mean diameters of 50 nm to 100 nm.

The method employing organic solvent is called reverse phase evaporation procedure. LUVs can be prepared by forming water-in-oil emulsions of lipids and aqueous buffer in excess organic phase, followed by removal of the organic phase under reduced pressure. Removal of the organic solvent under partial vacuum gives rise to hydrated lipid in the form of a viscous gel. Removal of the final traces of solvent under high vacuum or mechanical disruption, such as vortexing, causes the collapse of the gel into a smooth suspension of LUVs. Imura et al. (2002) recently developed a modified method, so called the supercritical reverse phase evaporation method (scRPE method), for the preparation of LUVs with diameters of 0.1 μm to 1.2 μm , in a single step using supercritical carbon dioxide (scCO_2) and ethanol.

The methods for producing LUVs indicated previously suffer from major drawbacks, including the use of toxic compounds during manufacture, low encapsulation efficiencies and irreproducibility of the liposome preparations. An alternative procedure that is gaining increasing popularity and would avoid the use of organic solvents and exhibit high trapping efficiency, involves the direct extrusion under moderate pressures of MLVs through polycarbonate filters of defined pore size (Chapman et al., 1991; MacDonald et al., 1991; Turanek, 1994; Berger et al., 2001). This procedure can generate LUVs with high trapping efficiency and size distributions within the range of 50 nm to 200 nm, depending on the pore size of the filter employed (Olson et al., 1979; Hope et al., 1986; Mayer et al., 1986). This procedure that avoids the use of organic solvents (Hope et al., 1985) can be applied to all liquid crystalline

bilayer lipids (including long chain saturated lipids) and lipid mixtures (Nayar et al., 1989; Hunter and Frisken, 1998). Therefore, the extrusion procedure is a considerably rapid, straightforward and convenient way for the reproducible production of homogeneously sized liposomes.

2.3.4 Sonication

In 1969, Huang succeeded in obtaining small and almost homogeneous spherical liposomes, with an average diameter of about 250 Å, by prolonged sonication of pure egg-yolk lecithin under nitrogen in 0.1 M buffered NaCl solution and subsequent molecular sieve chromatography on large-pore agarose gels.

Unilamellar liposomes are now usually prepared by either of two methods of sonication, one with a high energy probe immersed directly into an aqueous dispersion of lipid, or a lipid dispersion is placed in a glass vial suspended in a low energy ultrasonic cleaning bath.

The technique of using sonication as a method for producing homogeneous aqueous dispersions of lecithin has been described by many researchers (Bangham and Horne, 1964; Chapman et al., 1968; Huang and Thompson, 1974; Chong and Colbow, 1976). The effect of time of sonication on the size and shape of lecithin aggregates in aqueous dispersion has been studied by Attwood and Saunders (1965). They indicated that large and highly asymmetric particles within the lecithin dispersion are broken down by prolonged sonication to produce smaller and more symmetrical aggregates of round particles of a mean diameter between 100 Å and 200 Å. The increased interest in membrane structure and biological transport by using liposomes as a model membrane system in lipoprotein and enzyme studies has led to further

investigations on the effects of sonication on the structure of lecithin bilayers (Hauser, 1971; Sheetz and Chan, 1972).

Numerous reports on the effects of sonication dealt mainly on changes in the size and structure of the lipid aggregates. In the majority of studies, little attention has been paid to the possibility of chemical modification and degradation of the lipid induced by intense sonication. Most of the studies dealt with the physical properties of sonicated lipid dispersions and ignored the necessity of checking the purity of the lipid after sonication.

The extent of chemical degradation depended on the intensity of ultrasonic cavitation and probably on other factors which may influence the ultrasonic cavitation (Hauser, 1971). Further, the instrumental settings, the geometry of the probe relative to that of the sample tube, the volume, concentration, liquid depth and temperature of the dispersion, the depth to which the probe was immersed, the nature of the dissolved gas as well as the atmosphere surrounding the sample, were all found to influence the effect of sonication. In the light of the findings that under conditions of optimum cavitation even very short sonication times, can cause significant chemical degradation. Thus, purity tests of the lecithin before and after sonication are imperative. However, the insignificant effect of sonication on the state of lecithin molecules reported by Huang and Charlton (1972) is in contrast with the observation of Hauser (1971). This disagreement is not surprising but reasonable since different conditions of sonication were described.

2.4 Applications Involving Liposomes

Liposomes have long been used in basic research as model systems for biological membranes because they have structures and functions similar to those of biological membranes (Sessa and Weissmann, 1968). Due to their structure, chemical