

**PREPARATION AND PROPERTIES OF RUBBER SEED SHELL FLOUR
(RSSF)- FILLED POLYPROPYLENE (PP) COMPOSITES**

MOHAMAD DANIAL SHAFIQ

**UNIVERSITI SAINS MALAYSIA
2014**

**PREPARATION AND PROPERTIES OF RUBBER SEED SHELL FLOUR (RSSF)-
FILLED POLYPROPYLENE (PP) COMPOSITES**

by

MOHAMAD DANIAL SHAFIQ

Thesis submitted in fulfillment of the requirements

for the degree of

Master of Science

March 2014

ACKNOWLEDGEMENT

First of all, I would like to extend my sincere gratitude to my parents, Mr. Mohd Suhaimi Hashim and Mdm. Roszita Hashim for showering me with encouragements and love. Not forgetting my loving brothers and sisters that giving me all the encouragements and supports that I need.

I am especially indebted to my supervisor Prof. Dr. Hanafi Ismail and co-supervisor, Prof. Dr. Azlan Ariffin for their constant assistance, advices, and guidance that molded me into a researcher that armed with skill and knowledge to carry out my research with great perseverance. Sincere thanks are accorded to fellow technicians, Mr. Shahril, Mr. Suharuddin, Mr. Shahrizol, Mr Mohamad, Mr. Rashid, Mr. Khairi and Mr. Faizal for spending their valuable time and effort to help me with the experimental throughout this research study.

Special acknowledgement is accorded to my fellow postgraduate mates for giving me lots of helpful mentally and physically support to help me achieve my goals. Special thanks are also given to them for their sharing all the moments of joy, laugh and sad throughout my study days. My sincere thanks are also extended to all undergraduate friends for their support, encouragement and invaluable advice.

Finally, the Government of Malaysia and School of Materials and Mineral Resources Engineering, Universiti Sains Malaysia are also acknowledged for providing this research project and facilities during my study.

	Page
ACKNOWLEDGEMENTS.....	ii
TABLE OF CONTENTS.....	iii
LIST OF TABLES.....	viii
LIST OF FIGURES.....	x
LIST OF PLATES.....	xvii
LIST OF EQUATIONS.....	xviii
LIST OF SYMBOLS.....	xix
LIST OF ABBREVIATIONS.....	xx
ABSTRAK.....	xxii
ABSTRACT.....	xxiv
CHAPTER ONE: INTRODUCTION	
General introduction.....	1
1.1 Problem statements.....	4
1.2 Research objectives.....	5
1.3 Outline of thesis structure.....	6

CHAPTER TWO: LITERATURE REVIEW

2.1 Polyolefins; Polypropylene and High Density Polyethylene.....	7
2.2 Fillers.....	8
2.2.1 Natural Fillers.....	9
2.2.2 Applications and Advantages of Natural Fillers.....	11
2.2.3 Rubber Seed: Shell and Kernel.....	13
2.3 Mixing of Plastics.....	17
2.3.1 Types of mixing equipment.....	18
2.3.2 Internal mixer.....	22
2.3.3 Distribution and Dispersion.....	23
2.4 Composites.....	25
2.4.1 Polymer Matrix Composites (PMC).....	26
2.4.2 Disadvantages of PMC.....	28
2.5 Compatibilizers.....	29
2.5.1 Types of compatibilizers.....	30
2.5.2 Effects of compatibilization on polymers.....	31
2.6 Compression Molding.....	32

CHAPTER 3: EXPERIMENTAL AND MATERIALS

3.1 Materials.....	34
3.1.1 Polypropylene (PP).....	34
3.1.2 Rubber Seed Shell (RSS)	35
3.1.3 Compatibilizer.....	35
3.1.3.1 Polyethylene copolymerized Acrylic Acid.....	35
3.1.3.2 Phtalic Anhydride.....	36
3.1.3.3 Epoxidized Vegetable Oil.....	36
3.2 Sample Preparation.....	37
3.2.1 Preparation of RSSF.....	37
3.2.2 Preparation of PP/RSSF composites.....	37
3.2.3 Preparation of compatibilized PP/RSSF composites with.....	37
Polyethylene copolymerized Acrylic Acid (PE-co-AA)	
3.2.4 Preparation of compatibilized PP/RSSF composites with.....	38
Phtalic Anhydride (PA)	
3.2.5 Preparation of compatibilized PP/RSSF composites with.....	38
Epoxidized Vegetable Oil (EVO)	
3.2.6 Compression molding.....	39
3.3 Testing.....	40
3.3.1 Mechanical Properties.....	40
3.3.2 Morphological Properties.....	41
3.3.3 Water Absorption Properties.....	41
3.3.4 Thermal Properties.....	42

CHAPTER FOUR: RESULTS AND DISCUSSION

4.1 Effect of RSSF loading on the properties of PP composites.....	43
4.1.1 Processing properties.....	43
4.1.2 Tensile properties.....	45
4.1.3 Morphological properties.....	48
4.1.4 Flexural properties.....	50
4.1.5 Impact strength.....	52
4.1.6 Water absorption properties.....	53
4.1.7 Thermal properties.....	54
4.2 Effect of polyethylene copolymerized acrylic acid (PE-co-AA) as.....	58
compatibilizer on the properties of PP/RSSF composites	
4.2.1 Processing properties.....	58
4.2.2 Tensile properties.....	60
4.2.3 Morphological properties.....	63
4.2.4 Flexural properties.....	66
4.2.5 Impact strength.....	69
4.2.6 Water absorption properties.....	69
4.2.7 Thermal properties.....	71
4.3 Effect of phthalic anhydride (PA) as compatibilizer on the properties.....	76
of PP/RSSF composites	
4.3.1 Processing properties.....	76
4.3.2 Tensile properties.....	78

4.3.3 Morphological properties.....	82
4.3.4 Flexural properties.....	85
4.3.5 Impact strength.....	88
4.3.6 Water absorption properties.....	89
4.3.7 Thermal properties.....	91
4.4 Effect of epoxidized vegetable oil (EVO) as compatibilizer on.....	96
the properties of PP/RSSF composites	
4.4.1 Processing properties.....	96
4.4.2 Tensile properties.....	98
4.4.3 Morphological properties.....	102
4.4.4 Flexural properties.....	105
4.4.5 Impact strength.....	107
4.4.6 Water absorption properties.....	108
4.4.7 Thermal properties.....	110
CHAPTER FIVE: CONCLUSION	
5.1 Conclusion.....	115
5.2 Suggestions for further studies.....	116
REFERENCES.....	118
LIST OF PROCEEDING.....	134

LIST OF TABLES

	Page
Table 1.1 Tensile strength of common filled-polypropylene (Fu et al., 1999 and Kant et al., 2013)	3
Table 2.1 Composition of each fresh rubber seed (Pillai and Wijewanta, 1967)	14
Table 2.2 Composition of commonly used natural fibers (Malkapuram et al, 2009)	15
Table 2.3 Mechanical properties of commonly used natural fibers (Malkapuram et al, 2009)	16
Table 2.4 Compression molding parameters (Estabrook, 1998)	33
Table 3.1 Physical and mechanical properties of PP	34
Table 3.2 Composition of RSSF	35
Table 3.3 Properties of PE-co-AA	35
Table 3.4 Properties of PA	36
Table 3.5 Properties of EVO	36
Table 3.6 Formulations of PP/RSSF and compatibilized PP/RSSF composites	40
Table 4.1 Thermogravimetric analysis parameter of RSSF-filled PP composites at different filler loading	56
Table 4.2 Thermal degradation rate (weight loss(%)/min) of RSSF-filled PP composites at different filler content and temperature range	57

Table 4.3	Thermogravimetric analysis parameter of PE-co-AA-compatible PP/RSSF composites at different filler loading	75
Table 4.4	Thermal degradation rate (weight loss(%)/min) of uncompatibilized and PE-co-AA-compatible PP/RSSF composites at different filler content and temperature range	75
Table 4.5	Thermogravimetric analysis parameter of PA-compatible PP/RSSF composites at different filler loading	94
Table 4.6	Thermal degradation rate (weight loss(%)/min) of uncompatibilized and PA-compatible PP/RSSF composites at different filler content and temperature range	95
Table 4.7	Thermogravimetric analysis parameter of EVO-compatible PP/RSSF composites at different filler loading	113
Table 4.8	Thermal degradation rate (weight loss(%)/min) of uncompatibilized and EVO-compatible PP/RSSF composites at different filler content and temperature range	114

LIST OF FIGURES

	Page
Figure 1.1 Schematic explanation of polymer combination (Gupta, 2005)	1
Figure 4.1 Torque-time curves of PP/RSSF composites at different filler loading	44
Figure 4.2 Effect of filler loading on stabilization torque of PP/RSSF composites	45
Figure 4.3 Effect of filler loading on tensile strength of PP/RSSF composites	47
Figure 4.4 Effect of filler loading on elongation at break of PP/RSSF composites	47
Figure 4.5 Effect of filler loading on Young's modulus of PP/RSSF composites	48
Figure 4.6 SEM Micrograph of RSSF	49
Figure 4.7 Fracture surface micrograph of PP/RSSF composites at different filler loading	49
Figure 4.8 Effect of filler loading on flexural strength of PP/RSSF composites	51
Figure 4.9 Effect of filler loading on flexural modulus of PP/RSSF composites	51

Figure 4.10	Effect of filler loading on impact strength of PP/RSSF composites	52
Figure 4.11	Effect of filler loading on water uptake of PP/RSSF composites	53
Figure 4.12	Effect of filler loading on equilibrium water uptake of PP/RSSF composites	54
Figure 4.13	Thermograms of virgin PP and PP/RSSF composites at different filler loading	55
Figure 4.14	Torque-time curves of PE-co-AA-compatible PP/RSSF composites at different filler loading	59
Figure 4.15	Effect of filler content and PE-co-AA on stabilization torque of uncompatibilized and compatibilized PP/RSSF composites	60
Figure 4.16	Effect of filler content and PE-co-AA on tensile strength for uncompatibilized and compatibilized PP/RSSF composites	62
Figure 4.17	Effect of filler content and PE-co-AA on elongation at break for uncompatibilized and compatibilized PP/RSSF composites	62
Figure 4.18	Effect of filler content and PE-co-AA on Young's modulus for uncompatibilized and compatibilized PP/RSSF composites	63

Figure 4.19	Fracture surface micrograph for uncompatibilized and compatibilized PP/RSSF composites at different filler content	65
Figure 4.20	Effect of filler content and PE-co-AA on flexural strength for uncompatibilized and compatibilized PP/RSSF composites	67
Figure 4.21	Effect of filler content and PE-co-AA on flexural modulus for uncompatibilized and compatibilized PP/RSSF composites	68
Figure 4.22	Effect of filler content and PE-co-AA on impact strength for uncompatibilized and compatibilized PP/RSSF composites	69
Figure 4.23	Effect of filler content on water uptake of PE-co-AA-compatibilized PP/RSSF composites	70
Figure 4.24	Comparison on the effect of filler content on equilibrium water uptake of uncompatibilized and compatibilized PP/RSSF composites	71
Figure 4.25	Thermograms of virgin PP, uncompatibilized and compatibilized PP/RSSF composites at different filler loading	73

Figure 4.26	Torque-time curves of PA-compatible PP/RSSF composites at different filler loading	77
Figure 4.27	Effect of filler content and PA on stabilization torque of uncompatibilized and compatibilized PP/RSSF composites	78
Figure 4.28	Effect of filler content and PA on tensile strength for uncompatibilized and compatibilized PP/RSSF composites	80
Figure 4.29	Effect of filler content and PA on elongation at break for uncompatibilized and compatibilized PP/RSSF composites	81
Figure 4.30	Effect of filler content and PA on Young's modulus for uncompatibilized and compatibilized PP/RSSF composites	82
Figure 4.31	Fracture surface micrograph of uncompatibilized and compatibilized PP/RSSF composites at different filler loading	84
Figure 4.32	Effect of filler loading and PA on flexural strength of uncompatibilized and compatibilized	86

	PP/RSSF composites	
Figure 4.33	Effect of filler loading and PA on flexural modulus of uncompatibilized and compatibilized PP/RSSF composites	87
Figure 4.34	Effect of filler loading and PA on impact strength of uncompatibilized and compatibilized PP/RSSF composites	89
Figure 4.35	Effect of filler content on water uptake of PA-compatible PP/RSSF composites	90
Figure 4.36	Comparison on the effect of filler content on equilibrium water uptake of uncompatibilized and compatibilized PP/RSSF composites	91
Figure 4.37	Thermograms of virgin PP, uncompatibilized and compatibilized PP/RSSF composites at different filler loading	93
Figure 4.38	Torque-time curves of EVO-compatible PP/RSSF composites at different filler loading	97
Figure 4.39	Effect of filler content and EVO on stabilization	98

	torque of compatibilized and uncompatibilized PP/RSSF composites	
Figure 4.40	Effect of filler content and EVO on tensile strength for uncompatibilized and compatibilized PP/RSSF composites	100
Figure 4.41	Effect of filler content and EVO on elongation at break for uncompatibilized and compatibilized PP/RSSF composites	101
Figure 4.42	Effect of filler content and EVO on Young's modulus for uncompatibilized and compatibilized PP/RSSF composites	101
Figure 4.43	Fracture surface micrograph for uncompatibilized and compatibilized PP/RSSF composites at different filler content	103
Figure 4.44	Effect of filler content and EVO on flexural strength for uncompatibilized and compatibilized PP/RSSF composites	106
Figure 4.45	Effect of filler content and EVO on flexural modulus for uncompatibilized and compatibilized	106

	PP/RSSF composites	
Figure 4.46	Effect of filler content and EVO on impact strength for uncompatibilized and compatibilized PP/RSSF composites	108
Figure 4.47	Effect of filler content on water uptake of EVO-compatibilized PP/RSSF composites	109
Figure 4.48	Comparison on the effect of filler content on equilibrium water uptake of uncompatibilized and compatibilized PP/RSSF composites	110
Figure 4.49	Thermograms of virgin PP, uncompatibilized and EVO-compatibilized PP/RSSF composites at different filler loading	112

LIST OF PLATES

		Page
Plate 2.1	Drawing of Banbury's mixer (White and Bumm, 2011)	19
Plate 2.2	Continuous mixer (White and Bumm, 2011)	20
Plate 2.3	Screw design of single-screw extruder (Koc and Demiryurek, 2009)	21
Plate 2.4	Compression molding (Estabrook, 1998)	33

LIST OF EQUATIONS

		Page
Equation 2.1	Reynold's equation	18
Equation 3.1	Water absorption equation	41

LIST OF SYMBOLS

%	Percent
°C	Degree celcius
cm	Centimeter
µm	Micrometer
g	Gram
GPa	Giga pascal
hrs	Hours
J	Joule
kg	Kilo gram
kJ	Kilo joule
kN	Kilo Newton
kPa	Kilo Pascal
m ²	Meter square
min	Minute
ml	Mililiter
mm	Milimeter
MPa	Mega Pascal
rpm	Rotation per minute
wt. %	Weight percent
php	Part per hundred Polymer

LIST OF ABBREVIATIONS

LDPE	Low density polyethylene
LLDPE	Linear low density polyethylene
PP	Polypropylene
HDPE	High Density Polyethylene
PVC	Poly (vinyl chloride)
PIB	Polyisobutylene
PDMS	Polydimethylsiloxane
PA 6,6	Polyamide-6,6
NR	Natural Rubber
PLA	Poly- (lactic acid)
PEO	Poly Ethylene Oxide
SEBS	Styrene-Ethylene/ Butylene-Styrene
PBT	Phenylbenzobisthiazole
RSSF	Rubber Seed Shell Flour
RSS	Rubber Seed Shell
RSK	Rubber Seed Kernel
PALF	Pineapple Leaf Fiber
EFB	Empty Fruit Bunch
PE-co-AA	Polyethylene copolymerized Acrylic Acid
PA	Phthalic Anhydride
EVO	Epoxidized Vegetable Oil
MAH	Maleic Anhydride
EAA	Ethylene Acrylic Acid

SEM	Scanning Electron Microscopy
TGA	Thermogravimetric Analysis
MFI	Melt Flow Index
PMC	Polymer Matrix Composites
SMC	Sheet Molding Compound

PENYEDIAAN DAN SIFAT-SIFAT SERBUK KULIT BIJI GETAH SEBAGAI BAHAN PENGISI DALAM KOMPOSIT POLIPROPILENA

ABSTRAK

Dalam penyelidikan ini, serbuk kulit biji getah (RSSF) telah ditambahkan dalam polipropilena (PP) untuk menghasilkan komposit dengan ciri-ciri yang optimum. Muatan RSSF diubah dari 10 php hingga 40 php untuk dikaji kesan penambahan RSSF terhadap sifat-sifat pemprosesan, tensil, morfologi, lenturan, hentaman, penyerapan air dan sifat haba bagi komposit. Dalam siri kedua, kesan penambahan polietilena dikopolimer dengan asid akrilik (PE-co-AA) dikaji kepada sifat-sifat komposit PP/RSSF. Phthalik anhidrida (PA) telah ditambah sebagai bahan penyerasian secara berasingan ke dalam komposit PP/RSSF dalam siri ketiga. Dalam siri seterusnya, minyak sayuran terepoksida (EVO) telah ditambah sebagai bahan penyerasian dalam komposit PP/RSSF dengan jumlah yang tetap iaitu 7 php. Penyediaan bagi komposit telah dijalankan menggunakan pemproses campuran dalaman Haake Polydrive dengan suhu 180°C menggunakan kelajuan rotor 50 rpm. Penambahan RSSF dalam komposit telah meningkatkan tork penstabilan dalam komposit PP. Tambahan pula, penyerasian komposit PP/RSSF dengan PE-co-AA dan PA telah meningkatkan tork penstabilan PP/RSSF. Walaubagaimanapun, penambahan EVO mengurangkan tork penstabilan. Sifat-sifat tegangan menunjukkan bahawa penambahan RSSF di dalam PP atau HDPE mengurangkan kekuatan tensil dan pemanjangan pada takat putus, manakala, modulus Young meningkat. Ini disebabkan ketidakserasian PP dan RSSF mengakibatkan lekatan antara muka yang lemah. Penambahan RSSF dalam PP telah meningkatkan penyerapan air komposit kerana kehadiran lignosellulosa dalam RSSF, yang mewujudkan ikatan hidrogen dengan air.

Sifat haba PP dipertingkatkan dengan kehadiran RSSF. Penambahan PE-co-AA ,PA dan EVO secara umumnya meningkatkan sifat-sifat tensil, lenturan dan hentaman komposit kerana peningkatan dalam lekatan antara muka, disebabkan oleh ikatan kimia antara kumpulan berfungsi dalam bahan penyerasian dan RSSF. Sifat haba PP/RSSF diserasikan dengan PE-co-AA dan EVO adalah merosot pada suhu tinggi.

**PREPARATION AND PROPERTIES OF RUBBER SEED SHELL FLOUR
(RSSF)- FILLED POLYPROPYLENE (PP) COMPOSITES**

ABSTRACT

In this research, rubber seed shell flour (RSSF) was incorporated in polypropylene (PP) to determine the composites with optimum properties. RSSF loadings were varied from 10 php to 40 php to study the effect of adding RSSF on processing, tensile, morphological, flexural, impact, water absorption and thermal properties of PP/RSSF composites. In the second series, the effect of adding polyethylene copolymerized with acrylic acid (PE-co-AA) was studied, on the properties of PP/RSSF composites. Phthalic anhydride (PA) was added as a compatibilizer separately in PP/RSSF composites in the third series. In the next series, epoxidized vegetable oil (EVO) was added as a compatibilizer in PP/RSSF with fixed amount of 7 php. Preparation of the composites has been conducted in Haake Polydrive internal mixer with the temperature of 180°C using rotor speed of 50 rpm. The addition of RSSF in the composites increased the stabilization torque in PP composites. Furthermore, compatibilization of PP/RSSF composites with PE-co-AA and PA increased the stabilization torque of PP/RSSF. Somehow, the presence of EVO reduced the stabilization torque resulted from flexible and long chain of EVO. The addition of RSSF in PP reduced the tensile strength and elongation at break, somehow, the Young's modulus is improved. This is mainly caused by incompatibility of PP and RSSF resulted to poor interfacial adhesion. Clear observations were presented in SEM micrograph of tensile fracture surface. The incorporation of RSSF in PP has increased the water absorption of the composites

due to the presence of lignocelluloses in RSSF, which possibly creates hydrogen bonding with water. Thermal properties of PP is improved with the presence of RSSF. Tensile, flexural and impact properties of the composites were improved with the presence of PE-co-AA, PA and EVO. It is mainly due to the improvement in interfacial adhesion, promoted by secondary chemical bonding between functional groups in compatibilizers and RSSF. Reduction in water absorption of the compatibilized composites was observed and it is caused by reduction of micro voids resulted from improvement in interfacial bonding. Thermal properties of PE-co-AA and EVO-compatibilized PP/RSSF are deteriorated due to thermal instability at higher temperature.

CHAPTER ONE

INTRODUCTION

General Introduction

Combination of two or more materials traditionally provides improvement in properties of the end products. Wide variety of materials exist in nature and can be synthetically produced, are available in many forms and shapes. Whether it is natural or synthetic, the main contribution of adding second substituent is to reduce the usage of pure materials and simultaneously reduced the materials costing. Somehow in engineering practice, the favors are more referred to desired properties of a product, depending on the suitability of its applications. The principles include to properties that matter to engineering and science; physical, chemical and also mechanical (Gupta, 2005).

The combination of polymers can be classified under four categories including copolymers, polymer blends, polymer alloys and polymer composites as presented in Figure 1.1.

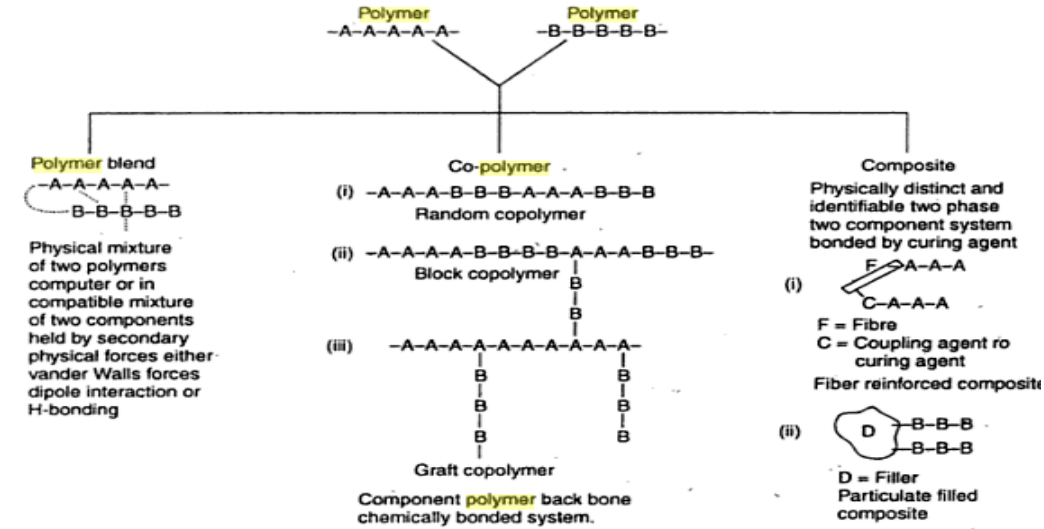

Figure 1.1. Schematic explanation on polymer combinations (Gupta, 2005)

Polymer composites are the materials that form aligned structure of stiff and strong substituents, called as filler or fiber in a binder or matrix. Fibers-reinforced polymers can be classified as composite materials, which involved the synergistic combination of two materials and produce end product (Yang et al, 2011). The second substituent, which is known as reinforcing material, usually provides stress accommodation and strongly bonded with the main component, polymer matrix and produces polymer composites with superior mechanical and chemical properties (Gupta, 2005; Dekkers and Heikens, 1983).

Researches involving the production of polymer composites received intensified acceptability due to the advantages promoted by polymer composites. In an engineering prospect, cost is always a matter. Cost is not limited to the production cost, but it is also focused on the selection of materials and the maintenances of the composites upon its service. The selection of proper polymer matrices and fillers, compounding and processing methods are crucial to make sure the usefulness of end polymer composites is appreciable to the total cost. Besides costing issues, the production of polymer composites is always referred to the contribution to the environment, especially when natural fibers are used (Rothon, 2003; Gupta, 2005). Plastic materials tend to deteriorate by mechanical, chemical and thermal means. The ability to degrade through microbial attack can be promoted by adding additives to solve plastic waste management problem. Additives such as starch have been added to polymers to produce biodegradable plastic, which have been the subject of interests these recent years. Not just that, natural materials such as kenaf, bamboo and banana stem are recently used to produce degradable polymer composites. Somehow, the incorporation natural

materials in polymers experiences some difficulties involving resulting physical properties of the plastic products compared to pure polymers. Netravali (1993) added that the efforts of developing polymer-based composite materials that made of fully sustainable plant based materials for both resin and fibers has become more popular lately due to the issue of sustainability. This shows that polymer composites are non-toxic and safe, whether during the processing and also upon its usage as products

The compositions of natural fillers; lignin and celluloses, resulted in inferior load-bearing capability of the end composites, if compared to synthetic-filled polymers. Somehow, the demand for natural fibers is predicted to grow 15-20% each year with major applications are packaging and automotive (Lancaster, 1972). Extensive research on composites made of natural renewable sources has increased the potential to produce cost effective polymer composites with acceptable mechanical properties mainly for packaging and automotive applications, substituting the need of using petroleum-based polymers. Table 1.1 shows tensile strength of PP and commonly used filled-PP composites.

Table 1.1: Tensile strength of common filled-polypropylene (Fu et al., 1999^a; Kant et al., 2013^b)

Materials	Tensile Strength (MPa)
Polypropylene (PP) ^b	31.3
Polypropylene/Short Glass Fiber (PP/SGF) ^a	46.5
Polypropylene/Short Carbon Fiber (PP/SCF) ^a	57.8
Polypropylene/Talc (PP/Talc) ^b	25.3

1.1 Problem Statement

Hydrocarbon plastic products have limited mechanical properties. Improvement in mechanical properties mainly can be observed by the addition of reinforcements and other additives but most crucially, these additives are harmful to the environment and human sometimes. Numerous recent studies are focused on the usage of natural additives; natural fillers or fibers as reinforcing agent in polymers. Not just that, filler from natural resources are cost effective, as most of the fillers are available naturally and ready to be incorporated in polymers. In addition, natural fillers are non-toxic and friendly to the environment and non-carcinogenic, during processing and also upon its service (Abdul Majid et al., 2009).

On a contrary, advantages that promoted by natural fillers in polymer matrix composites have some drawbacks. The addition of natural fillers in polymers has scored certain degrees of reduction in mechanical properties, namely tensile, flexural and also impact properties of the composites. Fuad et al. (1995) and Bose et al. (2004) concluded that the physical and chemical properties including particle size and shape and also chemical functional groups of natural fillers resulted in reduction of mechanical properties of the end composites. Furthermore, the compatibility issue rises from the interaction between inert polymer matrix and polar behavior of most natural fillers contributed to poor dispersion and adhesion of filler particles. Several remedies are found to improve the role of natural filler in reinforcing polymers, comparable to synthetic-filled polymers. Yang et al (2004) and Abdul Khalil et al. (2001) discussed that the filler treatment will improve the mechanical properties of natural-filled composites physically and chemically.

Improvement in matrix-filler interactions could possibly be formed by reaction between the compatibilizer added and natural filler and also surface modification of filler to promote surface activity.

1.2 Objectives

The objectives of the study are:

1. To compare the effect of adding rubber seed shell flour (RSSF) in polypropylene (PP) on the processing, tensile morphology, flexural, impact and water absorption properties of PP/RSSF composites.
2. To study the effect of adding polyethylene copolymerized with acrylic acid (PE-co-AA) in PP/RSSF composites on the processing, tensile morphology, flexural, impact and water absorption properties.
3. To determine the effect of adding phthalic anhydride (PA) in PP/RSSF composites on the processing, tensile morphology, flexural, impact and water absorption properties.
4. To determine the effect of adding epoxidized vegetable oil (EVO) in PP/RSSF composites on the processing, tensile morphology, flexural, impact and water absorption properties.

1.3 Outline of Thesis Structure

Chapter 1 starts with an introduction of the impact on the environment of the usage of petroleum based plastic and the advantages of using natural-filled polymer composites. In this chapter, the ways to curb environmental problems were discussed.

Chapter 2 is the literature review of the thesis. In this chapter, review on polyolefins, polymer composites, plastic mixing, advantages and limitations of natural filled-polymer composites were discussed.

Chapter 3 describes the materials, experimental procedures, equipments and tests to generate data in the present study.

Chapter 4 reports the comparison of adding RSSF in PP/RSSF and HDPE/RSSF composites. Then, few compatibilizers namely PE-co-AA, PA and EVO were added into the composites to study their role in the properties of the composites. Data, graphs and charts of the mechanical and morphology and water absorption properties of these composites are presented here. Discussion based on the data analysis is presented in this chapter as well.

Chapter 5 presents some concluding remarks on the present research study as well as some suggestions for future research.

CHAPTER TWO

LITERATURE REVIEW

2.0 Literature Review

Composites are made of two substituent namely, matrix and filler. In polymer matrix composites (PMC), most matrices are petroleum-based thermoplastics such as polypropylene (PP) and polyethylene (PE) (Zaaba et al., 2013). Fillers are used as reinforcing materials in composites, and there are two main types of fillers; synthetic and natural fillers (Sanadi et al., 1997). Natural fillers such as kenaf fiber, palm fiber and bamboo are widely used to produce sustainable polymer composites (Shebani et al., 2009). Further clarification on natural-filled composites will be discussed in this review.

2.1 Polypropylene

Polyolefin are polymers with the repeating units made of carbon and hydrogen atoms (Recycling Operators of New Zealand). Their usefulness in producing wide variety of applications including grocery bags, containers, toys, adhesives, home appliances, engineering plastics, automotive parts and medical instruments made polyolefin are always preferable in industries as thermoplastic matrices for PMC (Thomas and Pothan, 2008). PP was the first stereoregular polymer synthesized that demanded globally in the industries. However, PP has inferior mechanical properties at low temperature due to its glass transition temperature (T_g) is quite high (-20°C), compared to another widely used polyolefin, which is polyethylene.

Three components are required to manufacture polyolefins, including, monomer, initiator and reactor. PP was first produced in 1957 by Giulio Natta made from propylene monomer via Ziegler-Natta polymerization. Propylene was produced

started with the distillation of crude oil into naphtha and then undergoes cracking process and cracked into various olefins, including propylene. PP is produced with the approximate annual production of 8.4 millions metric tons into various forms such as pellets and fibers; filaments, tapes and strapping (Lepoutre, 2010).

PP is subdivided into ranges of grades, depending on applications. PP homopolymers are for general-purpose grades with versatile properties and PP block copolymers are PP, copolymerized with 15-20% ethylene to improve impact properties as discussed above. Random PP copolymers are manufactured for products requiring better clarity and flexibility (Lepoutre, 2010; Abdul Azeem, 2011).

2.2 Fillers

Fillers are used in polymers mainly to improve the mechanical properties of the composites, depending on applications such as for automotive parts, furniture and home appliances. Choosing suitable filler is important to justify the requirements of the end products. Not just that, compatibility between the matrix and filler is an important measure as well, further explained that types of polymeric matrices; thermoplastic or thermoset affect the end properties of composites. Lancaster (1972) discussed on different types of filler used in different types of polymeric matrices obtain certain desired properties of polymer-based bearing. For example, the incorporation of asbestos in PE and mica in polyphenylene oxide (PPO) show improvement in mechanical properties, while for thermosetting polymer resin, the addition of graphite in polyester has scored an improvement against friction (Lancaster, 1972). Solid lubricant fillers such as molybdenum disulphide (MoS_2) able to transfer stress to a metal counterface, proven that it is effective in reducing

coefficients of friction (Lancaster, 1965). On the other hand, the incorporation of natural filler in polymers draws much attention from researches recently.

2.2.1 Natural Fillers

Recent research and development have been expanded to the usage of natural filler in thermoplastic and thermoset resins to produce polymer composites (Malkapuram et al., 2009). The usage of fillers made of natural sources is not limited to daily used products, but natural-filled composites are used to manufacture automotive parts, insulation boards; thermal and noise and also structural parts (Wambua et al., 2003). Natural fillers are normally referred as materials made of natural sources and usually existed in fibrous form. Sisal, jute, kenaf, bamboo, banana, hemp, straw, rice husk are natural fibers that received attentions from researchers in recent researches (Nosbi et al., 2011; Herrera-Franco et al., 2004). Shebani et al. (2009) used several types of wood species including acacia, eucalyptus, pine and oak on the properties of linear low-density polyethylene (LLDPE)-based composites. From the research, they found that acacia wood species recorded the highest mechanical properties of end composites. They claimed that the composition of wood species; celluloses and lignin affects the result. Tensile strength of LLDPE/wood flour (acacia species) precisely beats tensile strength of pure LLDPE.

The content of most natural fibers; lignocelluloses, are more likely the same, but the amount of each composition differs from one another. As discussed earlier, amount of lignin and celluloses in acacia species wood flour are the highest compared to eucalyptus, pine and oak. Zaaba et al. (2013) reported same findings on the effect of composition of natural fibers on properties of composites. Zaaba et al. (2013), who

uses peanut shell in recycled PP claimed that types of matrix affect the properties of composites. Furthermore, types of cellulose and the geometry of the elementary cell affect the mechanical properties of natural fiber. Celluloses chains in natural fiber are arranged in parallel, linked by hydrogen bonds, forming bundles that consisted of forty or more cellulosic macromolecules through links with hemicelluloses, which contributed the stiffness of natural fibers (Giuseppe et al., 2010). The strength of natural fiber-filled composites is lower compared to the synthetic fiber-reinforced polymer composites, even under optimized fiber-matrix interactions (Heijenrath and Peijs, 1996; Berglund and Ericson, 1995)

Interfacial adhesion is a crucial factor in providing reinforcing effect of natural fillers in polymeric matrices. Ratio of lignin and celluloses in natural fibers play a role in promoting interfacial adhesion. Acacia species wood flour-filled LLDPE portrays better toughness and ductility behavior due to high celluloses content that resulted in improved interfacial adhesion between filler and matrix (Shebani et al., 2009). Somehow, interfacial interactions between natural fibers and polymer matrices are the main concern nowadays due to difference in hydrophilic character between these substituents (Thomas and Pothan, 2008). Li et al. (2008) has studied the mechanism of interfacial interactions between sisal fiber and HDPE. Complete debonding of single sisal fiber occurred when load is increased. The composite fails when matrix cracking started and absorbed the fracture energies, fiber fracture and the debonding of fiber-matrix interface (due to poor bonding), and resulted to fiber pull out (Li et al., 2008). Two approaches relating the debonding mechanism of fibers; interfacial shear stress (IFSS) and fracture mechanics (Lawrence, 1972; Gurney, 1967). Both parameters can be improved by modifying the matrix-fiber interface

chemically and physically (Le Duiguo et al., 2010). Poor matrix-filler interaction in natural fiber-filled polymer composites can be portrayed by non-uniformity of natural fiber structure unlike synthetic fibers; glass and carbon (Li et al., 2006).

2.2.2 Applications and Advantages of Natural Filler

Natural fillers draw global attentions recently and many researches have been performed concerning this interest, especially plant-based fibers due to its characters (Viet et al., 2011; Nosbi et al., 2011). Natural fiber-reinforced composites are versatile and suit for wide range of applications. In fact, composites made of natural fibers have ability to replace man-made fibers composites in most sectors (Malkapuram et al., 2009). Increasing demand of vehicles has great potentials in promoting natural fibers composites to produce automotive parts. Furthermore composites made of natural fibers are desirable in automobile industries due to its lightweight benefits fuel efficiency (Malkapuram et al., 2009; Alves et al., 2010).

Transformation towards sustainable future provides wide opportunities for natural fibers composites in producing eco-friendly plastic composites, replacing synthetic fibers composites such as carbon and glass fibers. Early production of biodegradable polymer composites focused on the incorporation of native starch in polymers. Somehow, the incorporation of starch in thermoplastic is limited at very low volume due to significant reduction of mechanical properties of composites (Kaplan et al., 2010). Plasticization is an alternative to improve mechanical properties of starch but starch has its importance in food industry that mainly focused in food additives and processing (Jin-Hui et al., 2006). Compositions of natural fibers; lignin and celluloses (as discussed earlier in this review) responsible on degradable and

hydrophilic characters of natural fibers. Huge numbers of researches on natural fiber polymer composites focus on serious environmental treat. Abdul Majid et al. (2010) discussed that the addition of kenaf fiber in thermoplastic starch aids degradability of composites and possess improved mechanical properties at the same time. Huda et al. (2007) mentioned that the incorporation of kenaf and bamboo fibers in poly (lactic acid) (PLA) has become an alternative to replace PP/Kenaf or PP/Bamboo fiber composites due to biocompatibility and biodegradability behavior of both PLA and natural fiber. In fact, reinforcing ability of kenaf and bamboo fiber is proven when added in PLA. Furthermore, the composite is preferable due to the escalating price of petroleum and also raw materials (Huda et al., 2007).

Natural fibers such as bamboo, kenaf, straw, jute, banana, sisal are widely available and easily found in nature. Besides, most natural fibers are industrial wastes and left abandoned in industries. For example, empty fruit bunch (EFB) fiber is collected in palm estates or industries, and the main product in the industry is palm oil for the production of cooking oil and soaps (Abu Bakar et al., 2005). Unlike synthetic fillers, processing characteristics of natural fiber composites are simple, cost-efficient and safe. Upon the manufacturing process of synthetic fibers itself, additives such as processing aids and stabilizer are required to control the integrity of the filaments and maintain the quality of synthetic fibers (Slade and Marcell, 1998; Wang et al., 2002). On a contrary, natural fibers are readily to be processed without concerning any health hazards and effects (Malkapuram et al., 2009). Furthermore, natural fiber composites are totally safe and non-toxic, whether upon the processing or its service. Extensive researches have been performed in producing corrugated boards, noise and weathering insulations and even marine docking by using natural fiber composites due to its non-

toxicity and friendliness to the environment and humans (Kissock et al., 1998 and Malkapuram et al., 2009).

Despite of being environmental friendly, natural fiber composites have inferior mechanical properties than composites made of synthetic fillers (Viet et al., 2011). However, Abdul Khalil et al. (2010) added that the mechanical properties of natural fiber composites can be improved through treatment and modification of natural fiber. He added the physical properties and character of kenaf fiber influence largely the mechanical properties of kenaf-filled thermoplastic composites. Further clarification on fiber modification and treatment will be discussed later in this review. In short, natural fiber itself has numerous advantages including, lightweight, degradable, availability, non-toxicity and harmless and easy to process, depending on applications.

2.2.3 Rubber Seed: Shell and Kernel

Hevea Brasilienses or natural rubber (NR) received its importance since over centuries ago. Rubber trees are now mainly planted in tropical regions of Asia, Africa and America. As the research develops, NR is found in more than 3000 species of plants including *Ficus elastica* (Moraceae), *Parthenium argentatum* and *Taraxacum koksaghyr* (Compositae). In addition. Limited source of NR is found in many other species like *Euphorbia intisy* (Euphorbiaceae), *Cryptostegia grandiflora*, *madagascariensis* (Asclepiadaceae), *Funtumia elastica* and *Landolphia*. However, *Hevea Brasiliensis* is still the most important commercial source of NR (Dean, 1987; Baker, 1997; Collins-Silva et al., 2012). Versatility of NR to produce numerous rubbery makes its demand is increasing each year.

The production of fruits starts when the rubber tree planted for four years. Eka et al. (2010) reported that each fruit contains four seeds and the seeds fall to the ground when the fruit harvests and splits. Annually, each tree is expected to yield approximately 800 seeds twice and each plantation is esmitated to produce 800-1200 kg of seed per year (Siriwardene and Nugara, 1972). Rubber seed is an agricultural by-product of the rubber tree. Rubber seed is lightweight, ovoid in shape and flattened on one side, which consists of hard and brittle shell loosely contained a cream-colored kernel (Nadarajah, 1969). Each rubber seed weighs approximately around three to six grams, depending on age of the seed and also moisture content. Table 2.1 shows the composition of fresh rubber seed.

Table 2.1: Composition of each fresh rubber seed (Pillai and Wijewanta, 1967)

Constituent	Amount (%)
Shell	35
Kernel	40
Moisture	25

As a part of natural habitats, the contents of RSS itself are most likely the same with other natural fillers such as kenaf and jute. As discussed earlier in this review, composition of natural filler, RSS in this case is responsible on its characteristics.

Table 2.2 and 2.3 compare the composition and tensile properties of commonly used natural fibers. It is clearly seen that the composition and the ratio of constituents affect the tensile properties of natural fibers and the composites. From Table 2.2 and 2.3, the mechanical properties of RSS can be predicted based on the composition of RSS as presented in Table 3.2 in the next chapter. Previous studies had revealed the

mineral composition of rubber seed shell carbon, which consists of magnesium, calcium, sodium and potassium (Eka et al., 2010 and Ekebafé et al., 2010). These contents are useful in providing the reinforcing effect of the end composites. In the same research, the rubber seed shell was carbonized up to 800°C and the carbonized-RSS was used in natural rubber as reinforcement (Ekebafé et al., 2010). The contents of the RSS; mineral and natural such as lignocelluloses, are able to provide synergistic effect on the mechanical properties of the composites as both of natural and mineral fillers are widely used in producing polymer matrix composites. Somehow, the major existence of lignocelluloses part in RSS, may reduce the mechanical properties of the composites. Moreover, large particles size of most natural fillers, including RSS, further weakens the strength of the composites.

Table 2.2: Composition of commonly used natural fibers (Malkapuram et al., 2009)

Fiber	Lignin (%)	Hemicellulose (%)	Cellulose (%)
Jute	12-13	13.6-20.4	61-71.5
Sisal	8-11	10.0-14.2	67-78
Hemp	3.7-5.7	17.9-22.4	70.2-74.4
Kenaf	13-15	21.5	31-39
Banana	5	19	63-67.6
Cotton	-	5.7	82.7

Table 2.3: Mechanical properties of commonly used natural fibers (Malkapuram et al., 2009)

Fiber	Tensile Strength (MPa)	Elongation at Break (%)	Young's Modulus (GPa)
Jute	393-793	1.16-1.5	13.26.5
Sisal	468-640	3-7	9.4-22
Hemp	690	1.6	-
Kenaf	-	2.7	-
Banana	1.7-7.9	1.5-9	-
Cotton	-	5.7	82.7

Another main constituent in rubber seed is the kernel. According to Bressani et al (1983), each of rubber seed kernel (RSK) contains 29.6% fat and 11.4% protein. This finding has received interests to investigate the role of RSK as food, feed and biofuel Eka et al discussed that fat and protein content in RSK have met nutrients requirement set by Food and Drug Administration (FDA) of the United States to serve as human food. Amino acid (protein) in RSK makes it good companion for maize as feed for animal. The fatty acid content of RSK promises to be valuable oil as a substitute or and additive to diesel and also for compression ignition engines (Eka et al., 2010).

Somehow, the only world's main economic interest of rubber plantation is the rubber latex for rubber products. The by-product such as rubber seed, draws few or no attention with the potential usefulness unattended. Improvement on the wastewater treatment has been promoted by the development of the agricultural by-product, and the usage as filler and extender in polymers (Cabral et al., 2005; Li and Sain 2005; Guffey and Sabbagh, 2002). Admittedly, the unique advantages of rubber seed such as being sustainable and environmental friendly, has prompted researchers nowadays to investigate composites made of natural filler, especially to suit humans daily used applications (Omofuma et al., 2011).

2.3 Mixing of Plastics

Plastic mixing that involves particulate solid fillers or additives with solid polymers are called as solid-solid mixing. Mixing process takes place when the mixture of polymer and filler achieved complete wetting of filler by polymer. In a different case, the addition of filler in molten polymer is called as solid-liquid mixing. Solid-liquid polymer mixing is occurred in plasticating screw extruders (Rauwendaal, 1998). Further discussion in mixing of polymer in extruder will be reviewed later. Basically, mixing is required to optimize desired properties of materials, depending on the applications or customer requirements (Davidson et al., 1985). Material characteristics such as heat and color stability, flame retardancy, impact resistance and more are necessities for customers satisfactory. In another term, mixing is usually referred as compounding, a process where the ingredients; polymers, fillers and additives are mixed together (Wildi and Maier, 1998).

Three important mechanisms of mixing are diffusion, turbulence and convective motion. Diffusion takes place when the material starts to spread into another without external driving forces and mainly contributed by coefficient of diffusion and resident time (Rauwendaal, 1998). Coefficient of diffusion of polymers depends on the viscosity of polymers and viscous polymers have very small coefficient of diffusion (Tseng et al., 2004). Secondly, fluid motion with randomly fluctuated velocities and pressures is called as turbulent flow. It happens when viscous forces of fluid are dominated by inertial forces and can be quantified by Reynolds number (Warholic et al., 1999).

$$N_{\text{reynolds}} = (\text{Density} \times \text{Velocity} \times \text{Diameter}) / \text{Viscosity} \quad (\text{Equation 2.1})$$

If the Reynolds number is more than 2100, the flow is said to be turbulence. Rauwendaal (1998) said that polymer flow will never achieve to the critical value of Reynolds number due to high viscosity of polymers, and mathematically, the velocity must be very high to achieve the critical amount, which is impossible to occur. In polymer processing, the flow is laminar or called as elastic turbulence. Thirdly, convective motion is a motion occurred in fluid flow, such as screw extruder and the driving forces are mainly influenced by pressure difference (Rauwendaal, 1998).

2.3.1 Types of mixing equipments

Two main types of mixing or compounding are practices in industries; batch and continuous process. Hancock discussed that batch mixers are the earliest that have been developed, namely masticator and two rolls mill. Both of these equipments are used for rubber compounding (White and Bumm, 2011). Later, single screw extrusion was developed and precisely produced wire and profiles products. Then, rotor mixers were introduced by Killhefner in 1962 when baking industries demands it (White and Bumm, 2011). Two types of rotor mixers were developed. Non-intermeshing rotor mixers are used then in rubber industries; tires after the attempt of using two rolls mill, but problems on the rotor performance were encountered (White and Bumm, 2011). Banbury modified the rotor to improve its mixing performance. The problems were contributed largely by the open atmosphere-mixing concept. The open atmosphere-mixing concept is not only lowered the ability of the rotor to mix the compound, but the workers are exposed to harmful chemicals (ingredients). In addition, Banbury found that the usage of ram is functional in providing better mixing. Then, Banbury's mixer was developed in 1915 (White and Bumm, 2011).

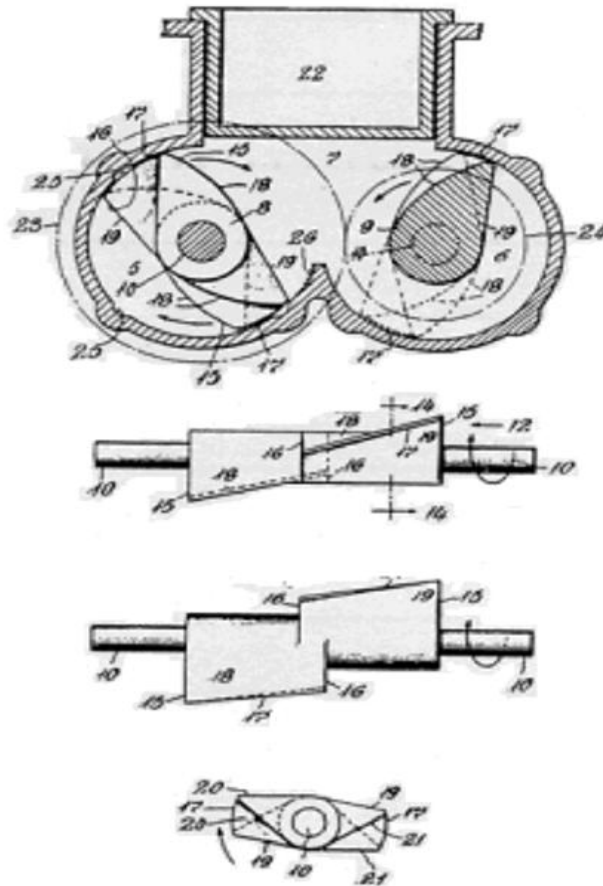

Plate 2.1. Drawing of Banbury's mixer (White and Bumm, 2011)

Banbury's mixer is now known as internal mixer. Slight modifications were performed on the rotor of internal mixer. Further review on internal mixer will be discussed later (White and Bumm, 2011).

Large dough in bakeries was the first reason of the development of continuous mixer and single screw extruder was the first commercialized continuous compounder (White and Bumm, 2011).

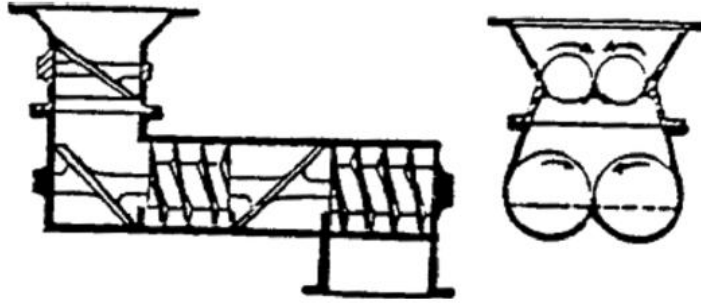

Plate 2.2. Continuous mixer (White and Bumm, 2011)

Many types of modified single-screw extruder, especially on the screw designs to improve mixing process. Rauwendaal (1998) describes that when solid polymer is introduced into the feed section of single-screw extruder, polymer pellets, granules, powder or regrinds are conveyed forward by frictional force and the mechanism is called as frictional drag. Friction at the barrel surface will keep the particles rotating and conveyed forward while the frictional force at screw is a retarding force due to the opposite direction from the conveyed melt. Rauwendaal (1998) added that frictional force is important to be maximized by adjusting the barrel temperature for effective conveying and to prevent melt from stagnant. In addition, grooving the barrel surface and applying a low-friction coating on the screw surface improves the conveying process. Then, the mixing process takes place at melting zone and it is achieved when the polymer has melted and analyzed by two main velocity components in the screw; velocity in the direction of the channel and cross-channel section (Rauwendaal, 1998).

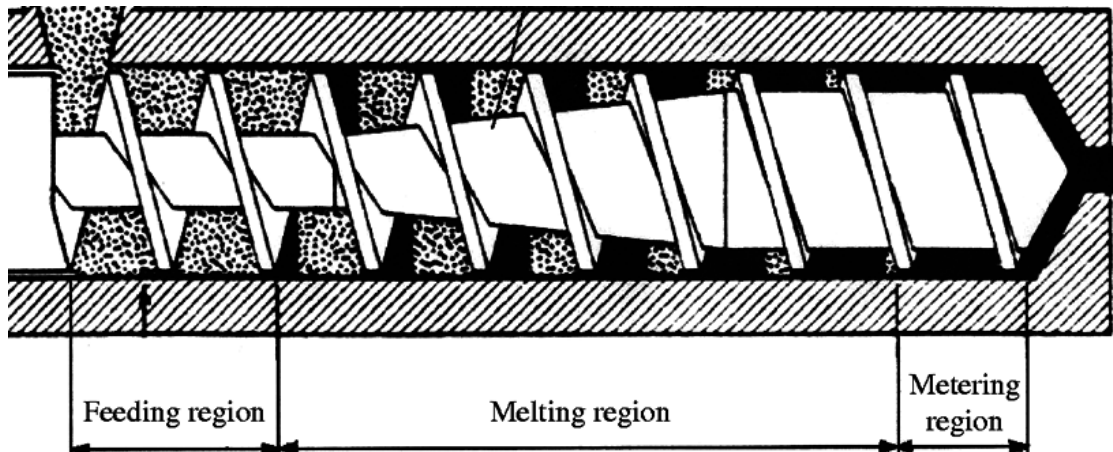

Plate 2.3. Screw design of single-screw extruder (Koc and Demiryurek, 2009)

Numerous range of polymeric materials can be readily processed by using continuous mixers including rubber compound, polyolefin, rigid and flexible PVC for various products such as pipes, tubes and other filled products. Continuous mixers are preferable for continuous products and also its advantages, namely low shear and heat history imparted on polymers and still providing good mixing. On a contrary, continuous mixers do not generate pressure and require additional equipment to pump the product through a die (Wildi and Maeier, 1998).

In general, continuous mixer is more advantageous than batch mixer. Short and residence time and uniformity of the compound resulted in excellent mechanical properties of the compound (Shon et al., 2008; White et al., 2006). Wide range of extruders were introduced including twin-screw extruder (co- and counter-rotating) and modular intermeshing twin-screw mixer, depending on types of materials (polymers and additives) and also applications.

2.3.2 Internal mixer

Internal mixer is a type of batch mixer. First internal mixer was developed with only a single rotor for mixing, and developed into twin rotor with open system. Then Banbury introduced closed chamber non- intermeshing internal mixer, equipped with ram to promote better mixing and sealing (Rauwendaal, 1998). Later in 1960s, intermeshing counter rotating rotor internal mixer was developed and marketed. Internal mixer is well known in polymer processing; especially in rubber compounding due to it can accept large clumps and ability to handle sticky and blocky materials. Mixing process takes place between the rotor, where high shear rate and elongation occur (Rauwendaal, 1998; White and Bumm, 2011).

Rauwendaal (1998) explained that the addition of the compounding ingredients is according to orders to maintain good mixing, dispersion and adequate stiffness in the mixture. Basic sequences start with the loading of polymers and one-half of the filler, then the remaining filler and lastly, other additives such as plasticizers or stabilizers. As the material starts to melt, torque value reduces and torque variation increases, Rauwendaal (1998) added. Torque value reached the maximum value when it is fully incorporated in polymer and reduces at the end of mixing process. White and Kim (1988) studied mixing characteristics and found that rate of homogenization of carbon black in rubber is faster and better in intermeshing rotor. Not just that, rotor speed and degree of fill play a role in the quality of mix. Ries (1988) explained that, at low rotor speed, the optimum degree of fill is approximately 80% and the quality of the mix is moderate while at higher rotor speed, with the optimum degree of fill is approximately 70%, the mix has better quality. The quality of mix is judged by the distribution and dispersion of fillers and additives in polymer matrix (Rauwendaal,

1998). Somehow, Rauwendaal (1998) added that the increment of rotor speed resulted in heat build-up, and this affects largely on low thermal stability materials and materials with crosslinker. A study on the effect of different processing methods on HDPE/SEBS composites has been performed and found out that preparation of the composites by using veneering and calendaring process resulted to the inferior conductivity and mechanical properties of the composites (Haddadi-Asl and Mohammadi, 1996). They claimed that shear stress applied is insufficient to provide better mixing and corporation of HDPE and SEBS, and improved conductivity and mechanical properties were noticed in composites prepared by twin-screw extruder and internal mixer. Rauwendaal (1998) added that internal mixer is advantageous in intensive mixing action and wide range of mixing procedure that allow the materials mixed and well distributed.

2.3.3 Distribution and Dispersion

Additives and reinforcements are added in polymers to achieve improved mechanical properties and impart certain desired properties of the mixture (Rauwendaal, 1998). Developing new and modified materials to suit certain product applications is more preferred by compounding instead of synthesizing chemically. Therefore the compounding mechanisms, which involved distribution and dispersion of mix must be precisely studied (Rauwendaal, 1998; Ica and Cheng, 1996).

Rauwendaal (1998) mentioned that distributive and dispersive mixing is important in polymer processing, especially in solid-solid mixing. Distributive mixing is more focused on the spreading the minor substituent (fillers and additives) in the sea of major material (matrix) in order to achieve good spatial distribution (Ica and Cheng,

1996). Dispersive mixing is more related to the reduction in size of the minor substituent, such as lumps and aggregates of solid particles. These two mechanisms occur simultaneously or stepwise (Ica and Cheng, 1996).

Cohesive forces holding agglomerates together with the disruptive hydrodynamic forces explain the condition of dispersive mixing. From a study of droplet breakup in mixing, in the case of low interfacial tension and high viscosity ratios of substituent, elongation flows are more effective than simple shear flows (Taylor, 1934; Rumscheidt and Mason, 1961). Powell and Mason (1982) studied on the effect of magnitude stress on the distribution of droplet size and found out that elongation flow enhance the process of agglomeration, compared with simple shear flow. More accurate approach of mixing efficiency involves the tracking of particles or droplets in the mixing equipments and following the dynamics of their breakup or coalesces. However, this approach is costly and requires high technology.

Random mixture and segregated mixtures are types of mixture that existed in the mixing of particulate solids. Random mixture explains the equal probability of finding a particle of any component same at all positions in the mixture with the proportion that component in the mixture as a whole. Segregated mixture is a mixture that has high probability of a component being in one part of the mixture and it is usually spotted in mixture that contains materials with different physical properties (Rauwendaal, 1998).

In distributive mixing, Lacey (1984) has distinguished three mechanisms, namely gravitational, shear and convective mixing. Gravitational and shear mixing