UNIVERSITI SAINS MALAYSIA

Peperiksaan Semester Kedua
Sidang Akademik 2004/2005
*Second Semester Examination
2004/2005 Academic Session*

Mac 2005
March 2005

ESA 202/3 – Simulasi dan Pemodelan Sistem Dinamik
Simulation and Modeling of Dynamic Systems

Masa : [3 jam]
Hour : [3 hours]

ARAHAN KEPADA CALON :
INSTRUCTION TO CANDIDATES

Sila pastikan bahawa kertas soalan ini mengandungi **TIGA BELAS (13)** mukasurat dan **LIMA (5)** soalan sebelum anda memulakan peperiksaan.

*Please ensure that this paper contains **THIRTEEN (13)** printed pages and **FIVE (5)** questions before you begin examination.*

Jawab **EMPAT (4)** soalan sahaja.
Answer **FOUR (4)** questions only.

Jawab semua soalan dalam Bahasa Malaysia.
Answer all questions in Bahasa Malaysia.

Setiap soalan mestilah dimulakan pada mukasurat yang baru.
Each questions must begin from a new page.

1. (a) Suatu sistem mekanikal asas yang terdiri daripada jisim, spring dan peredam digambarkan dalam Gambarajah 1(a).

A simple mechanical system of mass, spring and damper is shown in Figure 1(a).

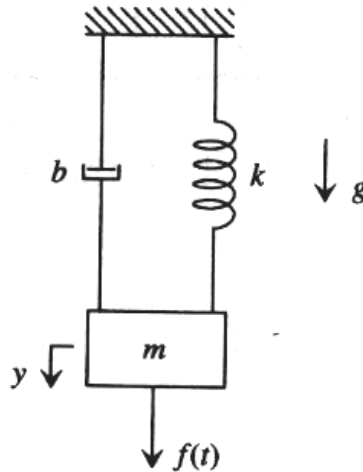

Gambarajah 1(a)/ *Figure 1(a)*

- (i) Lukis gambarajah jasad bebas

Draw the necessary free-body diagram

(10 markah/marks)

- (ii) Terbitkan persamaan pembezaan untuk sistem di atas

Derive the differential equation

(10 markah/marks)

- (iii) Dengan menggunakan persamaan pembezaan yang telah diterbitkan, tentukan

Using the differential equation obtained, determine

- (i) Perwakilan keadaan-ruang

State-space representation

(10 markah/marks)

- (ii) Rangkap pindah

Transfer function

(10 markah/marks)

- (b) Di bawah adalah persamaan-persamaan pembezaan untuk suatu sistem model dinamik.

$$M\ddot{x}_1 + b\dot{x}_1 - b\dot{x}_2 + kx_1 - kx_2 = 0$$

$$M\ddot{x}_2 - b\dot{x}_1 + b\dot{x}_2 - kx_1 + kx_2 = f$$

Below are the differential equations for a dynamic system model.

$$M\ddot{x}_1 + b\dot{x}_1 - b\dot{x}_2 + kx_1 - kx_2 = 0$$

$$M\ddot{x}_2 - b\dot{x}_1 + b\dot{x}_2 - kx_1 + kx_2 = f$$

- (i) Bina satu sistem model dinamik berasaskan persamaan pembezaan yang telah diberikan

Construct a mechanical system model based on the differential equation given

(10 markah/marks)

- (ii) Lukis Gambarajah jasad bebas

Draw the necessary free-body diagrams

(10 markah/marks)

- (iii) Tulis persamaan pembezaan di dalam bentuk keadaan ruang

Rewrite the differential equations in state-space model.

(10 markah/marks)

- (iv) Tentukan rangkap pindah

Determine the transfer functions.

(10 markah/marks)

- (c) Gambarajah 1(c) menunjukkan satu sistem bandul. Andaikan θ adalah keluaran sistem, tentukan perwakilan keadaan ruang bagi sistem ini.

Consider the pendulum system shown in Figure 1(c). Assuming θ to be the output of the systems, obtain a state-space representation for the system.

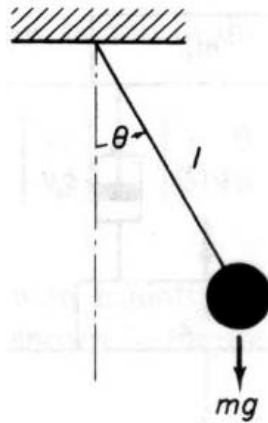

Gambarajah 1(c)/ Figure 1(c)

(20 markah/marks)

- 2 (a). Suatu sistem elektrik ditunjukkan dalam Gambarajah 2(a) di mana voltan v_a adalah kemasukan. Tentukan

Consider the electrical system shown in Figure 2(a), with the applied voltage v_a as the input. Determine the

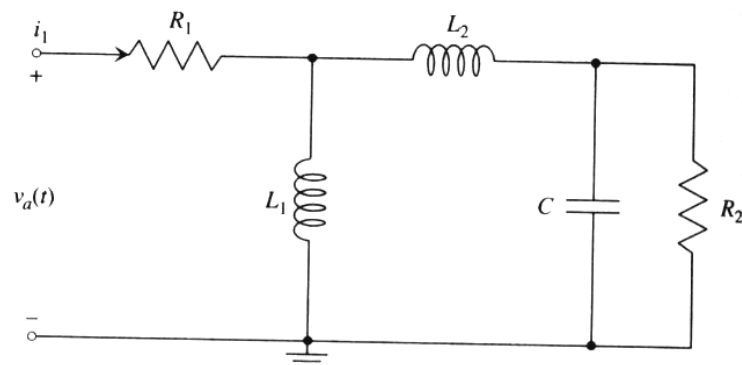

Gambarajah 2(a)/ Figure 2(a)

- (i) Persamaan Pembezaan

Differential equation

(10 markah/marks)

- (ii) Rangkap Pindah , $\frac{V_a(s)}{I_1(s)}$

Transfer function , $\frac{V_a(s)}{I_1(s)}$

(10 markah/marks)

- (iii) Berdasarkan persamaan pembezaan yang ditentukan, apakah analogi yang boleh dibuat untuk sistem elektrik tersebut.

Based on the differential equations obtained, what is the analogy can be described for the electrical system.

(10 markah/marks)

- (iv) Tulis persamaan pembezaan mekanikal yang analogi dengan sistem elektrik.

Rewrite the mechanical differential equations analogue to the electrical system

(10 markah/marks)

- (v) Lukis sistem mekanikal yang analogi dengan sistem elektrik

Draw the mechanical system analogue to electrical system

(20 markah/marks)

- (b) Tentukan model matematik untuk sistem-sistem yang ditunjukkan dalam Gambarajah 2b(i) dan (ii), dan tentukan mereka adalah analogi

Obtain mathematical models for the systems shown in Figure 2b (i) and (ii) and show that they are analogous systems.

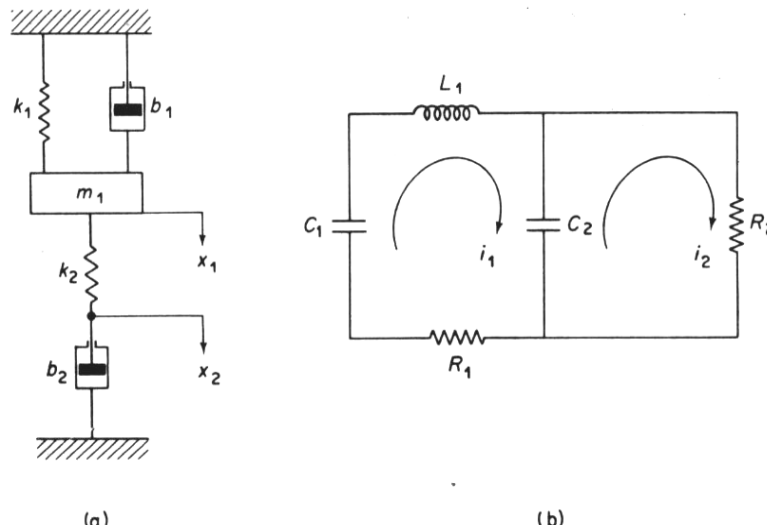

Gambarajah 2b (i) dan (ii)/ Figure 2b (i) and (ii)

(40 markah/marks)

3. (a) Suatu sistem yang ditentukan oleh keadaan ruang dan persamaan keluaran adalah seperti berikut:

$$\begin{aligned}\dot{x} &= Ax + Bu \\ y &= Cx + Du\end{aligned}$$

Consider a system described by the following state-equation and output equation

$$\begin{aligned}\dot{x} &= Ax + Bu \\ y &= Cx + Du\end{aligned}$$

di mana

$$A = \begin{bmatrix} 0 & 1 \\ -0.125 & -1.375 \end{bmatrix}, \quad B = \begin{bmatrix} -0.25 \\ 0.34375 \end{bmatrix}, \quad C = [1 \quad 0], \quad D = I$$

where

$$A = \begin{bmatrix} 0 & 1 \\ -0.125 & -1.375 \end{bmatrix}, \quad B = \begin{bmatrix} -0.25 \\ 0.34375 \end{bmatrix}, \quad C = [1 \quad 0], \quad D = I$$

Tentukan rangkap pindah untuk sistem ini.

Obtain the transfer function of this system.

(50 markah/marks)

- (b) Tentukan perwakilan keadaan ruang untuk sistem mekanikal yang ditunjukkan dalam Gambarajah 3(b) daya luar $u(t)$ yang dikenakan ke atas jisim m_2 adalah kemasukan sistem ini. Sasaran y dan z adalah keluaran sistem ini. Andaikan y dan z diukur daripada tempat keseimbangan masing-masing.

Obtain a state-space representation for the mechanical system shown in Figure 3(b). The external force $u(t)$ applied to mass m_2 is the input to the system. Displacement y and z are the outputs of the system. Assume that y and z are measured from their respective equilibrium positions.

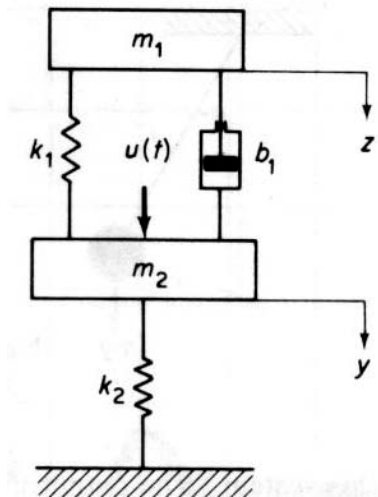

Gambarajah 3(b)/Figure 3(b)

(50 markah/marks)

4. (a) Bina satu gambarajah blok untuk sistem yang ditunjukkan dalam Gambarajah 4(a), di mana persamaan untuk model itu adalah

$$M\ddot{x} + B\dot{x} + Kx = f_a(t)$$

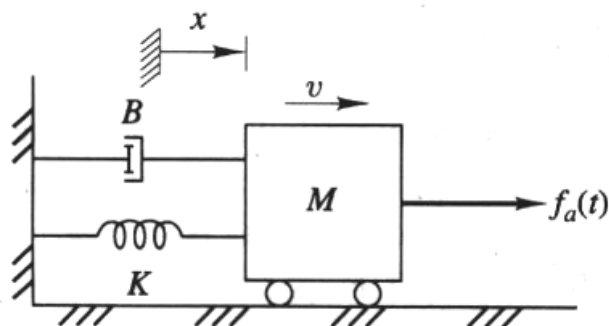

Gambarajah 4(a)/Figure 4(a)

(25 markah/marks)

- (b) Bina gambarajah blok untuk persamaan yang berikut

(i) $\dot{x} = -4x + 6y + 2u(t)$
 $\dot{y} = -2x - 3y$

(ii) $\dot{x}_1 = -3x_1 + 5x_2 + 3u(t)$
 $\dot{x}_2 = 4x_1 - 6x_2 - u(t)$

Draw block diagrams for each of the following models.

$$(i) \begin{aligned} \dot{x} &= -4x + 6y + 2u(t) \\ \dot{y} &= -2x - 3y \end{aligned}$$

(15 markah/marks)

$$(ii) \begin{aligned} \dot{x}_1 &= -3x_1 + 5x_2 + 3u(t) \\ \dot{x}_2 &= 4x_1 - 6x_2 - u(t) \end{aligned}$$

(15 markah/marks)

(c) Untuk sistem yang ditunjukkan dalam Gambarajah 4(c)

For the system shown in Figure 4(c),

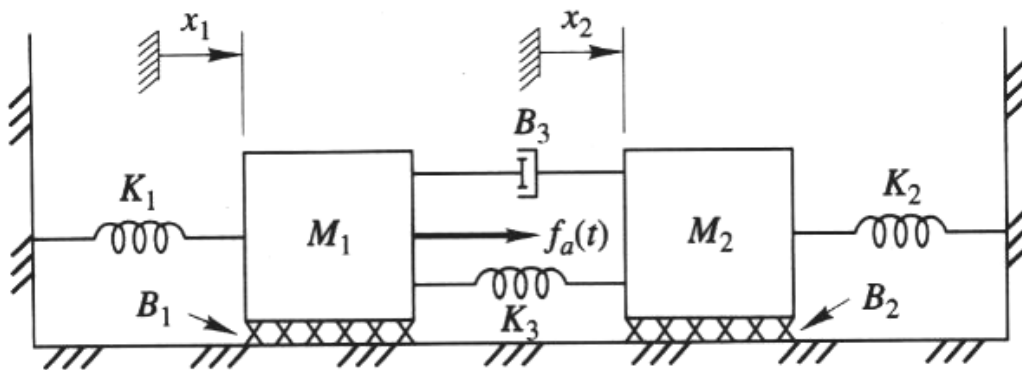

Gambarajah 4(c)/Figure 4(c)

(i) Lukis Gambarajah jasad bebas untuk setiap jisim

Draw the free-body diagram for each mass

(15 markah/marks)

(ii) Tulis persamaan pembezaan sistem tersebut

Write the differential equations describing the system

(15 markah/marks)

(ii) Bina satu Gambarajah blok untuk mewakili model ini.

Draw a block diagram to represent the model

(15 markah/marks)

5. Seorang penerjun payung terjun melompat keluar dari sebuah kapal terbang. Andaikan tiada angin dan payung terjun mengeluarkan redaman likat relative ke kerangka rujukan yang tetap. Payung terjun itu mempunyai jisim yang kecil, M_p dan pekali redaman B_p yang besar. Penerjun itu mempunyai berat M_j dan pekali seretan B_j yang kecil. Kord yang disambung dari payung terjun ke penerjun dipanggil “risers” dan diandaikan bersifat spring. Kesan elastik daripada “risers” diwakilkan melalui pekali spring K_R . Perubahan bentuk payung terjun juga boleh dimasukkan ke dalam pekali K_R . Satu model asas sistem tersebut ditunjukkan dalam Gambarajah 5.

A person wearing a parachute jumps out of an airplane. Assume that there is no wind and that the parachute provides viscous damping relative to a fixed reference frame. The parachute has a relatively small mass M_p and a large damping coefficient B_p . The jumper has a larger mass M_j and a smaller drag coefficient B_j . The cords attaching the parachute to the jumper are called risers and are assumed to be quite springy. The elastic effect of the risers is represented by the spring constant K_R . The deformation of the parachute itself can also be included in the value K_R . A simple model of the system is shown in Figure 5.

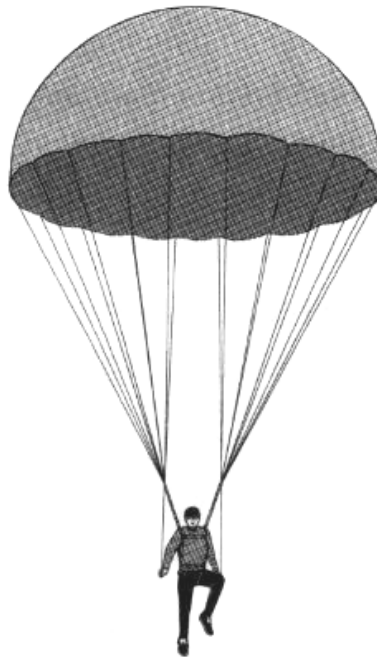

Gambarajah 5/ Figure 5

- (a) Lukis satu model asas sistem tersebut (Model asas adalah terdiri daripada jisim, spring dan peredam)

Draw a simple model representing the parachute. (Simple model consists of mass, spring and damper)

(40 markah/marks)

- (b) Terbitkan persamaan model untuk penerjun dan payung terjun berdasarkan model yang telah dilukis.

Write the modeling equations describing the motions of the jumper and the parachute.

(20 markah/marks)

- (c) Bina gambarajah blok untuk persamaan yang telah diterbitkan.

Draw the block diagrams based on the equations modeled.

(20 markah/marks)

- (d) Bina satu gambarajah 'simulink' berdasarkan gambarajah blok. (Kemasukan adalah dari unit step)

Construct a simulink diagram based on the block diagram. (Input is a unit step function)

(20 markah/marks)

LAPLACE TRANSFORM PAIRS

	$f(t)$	$F(s)$
1	Unit impulse $\delta(t)$	1
2	Unit step $1(t)$	$\frac{1}{s}$
3	t	$\frac{1}{s^2}$
4	$\frac{t^{n-1}}{(n-1)!} \quad (n = 1, 2, 3, \dots)$	$\frac{1}{s^n}$
5	$t^n \quad (n = 1, 2, 3, \dots)$	$\frac{n!}{s^{n+1}}$
6	e^{-at}	$\frac{1}{s+a}$
7	te^{-at}	$\frac{1}{(s+a)^2}$
8	$\frac{1}{(n-1)!} t^{n-1} e^{-at} \quad (n = 1, 2, 3, \dots)$	$\frac{1}{(s+a)^n}$
9	$t^n e^{-at} \quad (n = 1, 2, 3, \dots)$	$\frac{n!}{(s+a)^{n+1}}$
10	$\sin \omega t$	$\frac{\omega}{s^2 + \omega^2}$
11	$\cos \omega t$	$\frac{s}{s^2 + \omega^2}$
12	$\sinh \omega t$	$\frac{\omega}{s^2 - \omega^2}$
13	$\cosh \omega t$	$\frac{s}{s^2 - \omega^2}$
14	$\frac{1}{a}(1 - e^{-at})$	$\frac{1}{s(s+a)}$
15	$\frac{1}{b-a}(e^{-at} - e^{-bt})$	$\frac{1}{(s+a)(s+b)}$
16	$\frac{1}{b-a}(be^{-bt} - ae^{-at})$	$\frac{s}{(s+a)(s+b)}$

	$f(t)$	$F(s)$
17	$\frac{1}{ab} \left[1 + \frac{1}{a-b} (be^{-at} - ae^{-bt}) \right]$	$\frac{1}{s(s+a)(s+b)}$
18	$\frac{1}{a^2} (1 - e^{-at} - ate^{-at})$	$\frac{1}{s(s+a)^2}$
19	$\frac{1}{a^2} (at - 1 + e^{-at})$	$\frac{1}{s^2(s+a)}$
20	$e^{-at} \sin \omega t$	$\frac{\omega}{(s+a)^2 + \omega^2}$
21	$e^{-at} \cos \omega t$	$\frac{s+a}{(s+a)^2 + \omega^2}$
22	$\frac{\omega_n}{\sqrt{1-\zeta^2}} e^{-\zeta\omega_n t} \sin \omega_n \sqrt{1-\zeta^2} t$	$\frac{\omega_n^2}{s^2 + 2\zeta\omega_n s + \omega_n^2}$
23	$-\frac{1}{\sqrt{1-\zeta^2}} e^{-\zeta\omega_n t} \sin (\omega_n \sqrt{1-\zeta^2} t - \phi)$ $\phi = \tan^{-1} \frac{\sqrt{1-\zeta^2}}{\zeta}$	$\frac{s}{s^2 + 2\zeta\omega_n s + \omega_n^2}$
24	$1 - \frac{1}{\sqrt{1-\zeta^2}} e^{-\zeta\omega_n t} \sin (\omega_n \sqrt{1-\zeta^2} t + \phi)$ $\phi = \tan^{-1} \frac{\sqrt{1-\zeta^2}}{\zeta}$	$\frac{\omega_n^2}{s(s^2 + 2\zeta\omega_n s + \omega_n^2)}$
25	$1 - \cos \omega t$	$\frac{\omega^2}{s(s^2 + \omega^2)}$
26	$\omega t - \sin \omega t$	$\frac{\omega^3}{s^2(s^2 + \omega^2)}$
27	$\sin \omega t - \omega t \cos \omega t$	$\frac{2\omega^3}{(s^2 + \omega^2)^2}$
28	$\frac{1}{2\omega} t \sin \omega t$	$\frac{s}{(s^2 + \omega^2)^2}$
29	$t \cos \omega t$	$\frac{s^2 - \omega^2}{(s^2 + \omega^2)^2}$
30	$\frac{1}{\omega_2^2 - \omega_1^2} (\cos \omega_1 t - \cos \omega_2 t) \quad (\omega_1^2 \neq \omega_2^2)$	$\frac{s}{(s^2 + \omega_1^2)(s^2 + \omega_2^2)}$
31	$\frac{1}{2\omega} (\sin \omega t + \omega t \cos \omega t)$	$\frac{s^2}{(s^2 + \omega^2)^2}$

PROPERTIES OF LAPLACE TRANSFORMS

1	$\mathcal{L}[Af(t)] = AF(s)$
2	$\mathcal{L}[f_1(t) \pm f_2(t)] = F_1(s) \pm F_2(s)$
3	$\mathcal{L}_{\pm}\left[\frac{d}{dt}f(t)\right] = sF(s) - f(0_{\pm})$
4	$\mathcal{L}_{\pm}\left[\frac{d^2}{dt^2}f(t)\right] = s^2F(s) - sf(0_{\pm}) - \dot{f}(0_{\pm})$
5	$\mathcal{L}_{\pm}\left[\frac{d^n}{dt^n}f(t)\right] = s^nF(s) - \sum_{k=1}^n s^{n-k} f^{(k-1)}(0_{\pm})$ <p style="text-align: center;">where $f^{(k-1)}(t) = \frac{d^{k-1}}{dt^{k-1}}f(t)$</p>
6	$\mathcal{L}_{\pm}\left[\int f(t) dt\right] = \frac{F(s)}{s} + \frac{\left[\int f(t) dt\right]_{t=0_{\pm}}}{s}$
7	$\mathcal{L}_{\pm}\left[\iint f(t) dt dt\right] = \frac{F(s)}{s^2} + \frac{\left[\int f(t) dt\right]_{t=0_{\pm}}}{s^2} + \frac{\left[\iint f(t) dt dt\right]_{t=0_{\pm}}}{s}$
8	$\mathcal{L}_{\pm}\left[\int \cdots \int f(t) (dt)^n\right] = \frac{F(s)}{s^n} + \sum_{k=1}^n \frac{1}{s^{n-k+1}} \left[\int \cdots \int f(t) (dt)^k\right]_{t=0_{\pm}}$
9	$\mathcal{L}\left[\int_0^t f(t) dt\right] = \frac{F(s)}{s}$
10	$\int_0^{\infty} f(t) dt = \lim_{s \rightarrow 0} F(s) \quad \text{if } \int_0^{\infty} f(t) dt \text{ exists}$
11	$\mathcal{L}[e^{-at}f(t)] = F(s+a)$
12	$\mathcal{L}[f(t-\alpha)1(t-\alpha)] = e^{-as}F(s) \quad \alpha \geq 0$
13	$\mathcal{L}[tf(t)] = -\frac{dF(s)}{ds}$
14	$\mathcal{L}[t^2f(t)] = \frac{d^2}{ds^2}F(s)$
15	$\mathcal{L}[t^n f(t)] = (-1)^n \frac{d^n}{ds^n} F(s) \quad n = 1, 2, 3, \dots$
16	$\mathcal{L}\left[\frac{1}{t}f(t)\right] = \int_s^{\infty} F(s) ds \quad \text{if } \lim_{t \rightarrow 0} \frac{1}{t}f(t) \text{ exists}$
17	$\mathcal{L}\left[f\left(\frac{t}{a}\right)\right] = aF(as)$

Transfer function from State-Space Equation

$$G(s) = C(sI-A)^{-1}B + D$$

ooo000ooo