UNIVERSITI SAINS MALAYSIA

Second Semester Examination
Academic Session 2004/2005

*Peperiksaan Semester Kedua
Sidang Akademik 2004/2005*

March 2005
Mac 2005

EKC 367E – Plant Safety
[Keselamatan Loji]

Duration : 3 hours
[Masa : 3 jam]

Please ensure that this examination paper contains NINE printed pages and THREE printed pages of Appendix before you begin the examination.

[Sila pastikan bahawa kertas peperiksaan ini mengandungi SEMBILAN muka surat yang bercetak dan TIGA muka surat Lampiran sebelum anda memulakan peperiksaan ini.]

Instruction: Answer **FOUR (4)** questions. Answer any **TWO (2)** questions from Section A. Answer any **TWO (2)** questions from Section B.

Arahan: Jawab **EMPAT (4)** soalan. Jawab mana-mana **DUA (2)** soalan dari Bahagian A. Jawab mana-mana **DUA (2)** soalan dari Bahagian B.]

[Pelajar dibenarkan menjawab semua soalan dalam Bahasa Inggeris ATAU Bahasa Malaysia ATAU kombinasi kedua-duanya.]

Section A : Answer any TWO questions.

Bahagian B : Jawab mana-mana DUA soalan.

1. [a] Define the following:

- [i] OSHA incidence rate
- [ii] Fatal accident rate (FAR)
- [iii] Fatality rate

[6 marks]

[b] A plant employs 2000 full time workers with a process of FAR 4. What is the expected time needed for a single death incident to occur in this plant?

[4 marks]

[c] Phenol solution was made in water to observe its toxicity on insect. The insects were examined one day after spraying of phenol solution.

Dose of phenol	Number of insects tested	Number of insects affected
0	48	0
2.0	50	8
3.8	49	18
5.2	45	28
6.5	48	45
8.0	50	48

- [i] From the data given, plot the percent of insects affected versus log of the dose.
- [ii] Convert the data to a probit variable and plot the probit versus the log of the dose. If the result is linear, determine a straight line that fits the data.
- [iii] Compare the probit and number of insects affected predicted by the straight line fit to the actual data.

Table Q. 1. [c] The Transformation from percentages to probits.

%	0	1	2	3	4	5	6	7	8	9
0	-	2.67	2.95	3.12	3.25	3.36	3.45	3.52	3.59	3.66
10	3.72	3.77	3.82	3.87	3.92	3.96	4.01	4.05	4.08	4.12
20	4.16	4.19	4.23	4.26	4.29	4.33	4.36	4.39	4.42	4.45
30	4.48	4.50	4.53	4.56	4.59	4.61	4.64	4.67	4.69	4.72
40	4.75	4.77	4.80	4.82	4.85	4.87	4.90	4.92	4.95	4.97
50	5.00	5.03	5.05	5.08	5.10	5.13	5.15	5.18	5.20	5.23
60	5.25	5.28	5.31	5.33	5.36	5.39	5.41	5.44	5.47	5.50
70	5.52	5.55	5.58	5.61	5.64	5.67	5.71	5.74	5.77	5.81
80	5.84	5.88	5.92	5.95	5.99	6.04	6.08	6.13	6.18	6.23
90	6.28	6.34	6.41	6.48	6.55	6.64	6.75	6.88	7.05	7.33
%	0.0	0.1	0.2	0.3	0.4	0.5	0.6	0.7	0.8	0.9
99	7.33	7.37	7.41	7.46	7.51	7.58	7.65	7.75	7.88	8.09

[15 marks]

...3/-

1. [a] Takrifkan yang berikut:

- [i] Kadar kejadian OSHA
- [ii] Kadar kemalangan maut
- [iii] Kadar maut

[6 markah]

[b] Sebuah loji mempunyai 2000 pekerja sepenuh masa bagi suatu proses yang mempunyai FAR 4. Berapakah masa yang dijangkakan bagi satu kejadian kematian untuk berlaku di dalam loji tersebut?

[4 markah]

[c] Satu larutan fenol disediakan di dalam air untuk memerhatikan ketoksidaannya terhadap serangga. Serangga diperiksa sehari selepas disemburkan larutan fenol.

Dos fenol	Bil. serangga yang diuji	Bil. serangga yang terkesan
0	48	0
2.0	50	8
3.8	49	18
5.2	45	28
6.5	48	45
8.0	50	48

- [i] Daripada data yang diberikan, plot peratus serangga yang terkesan melawan log dos.
- [ii] Tukarkan data kepada pembolehubah probit dan plotkan probit melawan log dos. Jika hasilnya adalah linear, tentukan garis lurus yang sepadan dengan data sebenar.
- [iii] Bandingkan probit dan bilangan serangga yang terkesan seperti yang dijangka oleh padanan garis lurus dan data sebenar.

Jadual S. 1. [c] Pertukaran daripada peratus probit.

%	0	1	2	3	4	5	6	7	8	9
0	-	2.67	2.95	3.12	3.25	3.36	3.45	3.52	3.59	3.66
10	3.72	3.77	3.82	3.87	3.92	3.96	4.01	4.05	4.08	4.12
20	4.16	4.19	4.23	4.26	4.29	4.33	4.36	4.39	4.42	4.45
30	4.48	4.50	4.53	4.56	4.59	4.61	4.64	4.67	4.69	4.72
40	4.75	4.77	4.80	4.82	4.85	4.87	4.90	4.92	4.95	4.97
50	5.00	5.03	5.05	5.08	5.10	5.13	5.15	5.18	5.20	5.23
60	5.25	5.28	5.31	5.33	5.36	5.39	5.41	5.44	5.47	5.50
70	5.52	5.55	5.58	5.61	5.64	5.67	5.71	5.74	5.77	5.81
80	5.84	5.88	5.92	5.95	5.99	6.04	6.08	6.13	6.18	6.23
90	6.28	6.34	6.41	6.48	6.55	6.64	6.75	6.88	7.05	7.33
%	0.0	0.1	0.2	0.3	0.4	0.5	0.6	0.7	0.8	0.9
99	7.33	7.37	7.41	7.46	7.51	7.58	7.65	7.75	7.88	8.09

[15 markah]

...4/-

2. [a] Discuss the following :

[i] TLV – TWA

[ii] TLV – STEL

[iii] TLV – C

[6 marks]

[b] Discuss on various chemical plant control techniques which are used to protect employees from accidents and occupational health hazards in process industries.

[9 marks]

[c] A drum contains 50 liters of ethyl acetate. If the lid of the drum is left opened (lid diameter = 20 cm), determine:

[i] Time required to evaporate all of the ethyl acetate from the drum.

[ii] Concentration of ethyl acetate (in ppm) near the drum if the local ventilation rate is $30 \text{ m}^3/\text{min}$.

Data : Temperature of ethyl acetate is 27°C

Saturation vapor pressure of ethyl acetate = 100 mmHg

Density of ethyl acetate = 0.9 gm/cm^3

$R_g = 82.057 (\text{cm}^3)(\text{atm}) / (\text{mol}) (\text{K})$

Mass transfer coefficient of water = 0.83 cm/s

Molecular weight of ethyl acetate = 88

[10 marks]

2. [a] *Bincangkan perkara-perkara berikut :*

[i] *TLV – TWA*

[ii] *TLV – STEL*

[iii] *TLV – C*

[6 markah]

[b] *Bincangkan pelbagai teknik kawalan loji kimia yang digunakan untuk melindungi pekerja daripada kemalangan dan bahaya kesihatan pekerjaan di dalam industri proses.*

[9 markah]

...5/-

[c] Satu tong mengandungi 50 liter etil asetat. Jika penutup tong dibiarkan terbuka (diameter penutup = 20 sm), tentukan:

[i] Masa yang diperlukan untuk menyejatkan kesemua etil asetat daripada tong.

[ii] Kepekatan etil asetat (di dalam ppm) berhampiran tong jika kadar pengudaraan setempat adalah $30 \text{ m}^3/\text{min}$.

Data : Suhu etil asetat adalah 27°C

Tekanan wap tepu etil asetat = 100 mmHg

Ketumpatan etil asetat = 0.9 gm/sm^3

$R_g = 82.057 (\text{sm}^3)(\text{atm}) / (\text{mol}) (K)$

Pekali pemindahan jisim air = 0.83 sm/s

Berat molekul etil asetat = 88

[10 markah]

3. [a] Describe the parameters which affect atmospheric dispersion of toxic materials.

[b] Derive the fundamental equation of dispersion model taking into account wind velocity, eddy diffusivity effect on the pollutant together with appropriate boundary and appropriate initial conditions.

[c] Derive dispersion model for steady state, continuous point source release with wind and constant eddy diffusivity in all directions.

[15 marks]

[d] In a resin manufacturing plant it was noticed that a leak occurred in the storage tank containing benzene. The leak was 10 mm in diameter and 2 m above the bottom of the tank. When the leak started, the solvent level inside the tank was 5 m above the bottom of the tank. The diameter of the tank was 1 m.

[i] Determine initial mass discharge rate

[ii] Determine the total time to leak out the benzene

Data given: Storage tank was at atmospheric pressure

Specific gravity of benzene = 0.87

Density of water = 1000 kg/m^3

$g = 9.8 \text{ m/s}^2$

$g_c = 1 \text{ kg.m/s}^2.\text{N}$

$C_0 = 0.61$

...6/-

Useful Relations :
$$Q_m = \rho C_0 A \sqrt{2 \left(\frac{g_c P_g}{\rho} + gh_L^o \right)} - \frac{\rho_g C_0^2 A^2}{A_t} t$$

$$t_e = \frac{1}{C_0 g} \left(\frac{A_t}{A} \right) \left[\sqrt{2 \left(\frac{g_c P_g}{\rho} + gh_L^o \right)} - \sqrt{\frac{2 g_c P_g}{\rho}} \right]$$

[10 marks]

3. [a] Huraikan parameter-parameter yang memberi kesan kepada penyerakkan bahan toksik.
- [b] Terbitkan persamaan asas model penyerakan yang mengambilkira halaju angin, kesan kemeresapan pusing ke atas bahan pencemar bersama dengan sempadan yang bersesuaian dan keadaan awal yang bersesuaian.
- [c] Terbitkan model penyerakan bagi keadaan mantap, pelepasan sumber titik berterusan dengan angin dan kemeresapan pusing malar di dalam semua arah.

[15 markah]

- [d] Di dalam sebuah loji pembuatan resin, didapati suatu kebocoran berlaku di dalam tangki simpanan yang mengandungi benzena. Kebocoran tersebut berdiameter 10 mm dan berada 2 m daripada bawah tangki. Apabila kebocoran bermula, aras pelarut di dalam tangki adalah 5 m daripada bawah tangki. Diameter tangki tersebut adalah 1 m.

- [i] Tentukan kadar buangan jisim awal.
- [ii] Tentukan masa keseluruhan untuk benzena mengalir keluar.

Data diberi: Tangki simpanan pada tekanan atmosfera

Graviti spesifik benzena = 0.87

Ketumpatan air = 1000 kg/m³

$g = 9.8 \text{ m/s}^2$

$g_c = 1 \text{ kg.m/s}^2.N$

$C_0 = 0.61$

Hubungan :
$$Q_m = \rho C_0 A \sqrt{2 \left(\frac{g_c P_g}{\rho} + gh_L^o \right)} - \frac{\rho_g C_0^2 A^2}{A_t} t$$

$$t_e = \frac{1}{C_0 g} \left(\frac{A_t}{A} \right) \left[\sqrt{2 \left(\frac{g_c P_g}{\rho} + gh_L^o \right)} - \sqrt{\frac{2 g_c P_g}{\rho}} \right]$$

[10 markah]

...7/-

Section B : Answer any **TWO** questions.

Bahagian B : Jawab mana-mana **DUA** soalan.

4. [a] Describe two methods that are commonly used in process industries to prevent fire and explosion.

[7 marks]

- [b] A tanker carrying 700 kg propane and 300 kg butane had an accident at kilometers 200 at the North-South highway. The tank ruptured and formed a vapour cloud. The cloud was ignited 10 seconds later and resulting in a huge explosion. Determine the impact of overpressure at 500 m from the source.

Data:

Appendix A: Correlation between overpressure and scaled distance

Standard heat of formation, H_f°

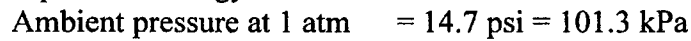
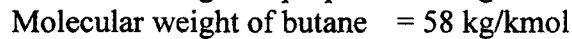
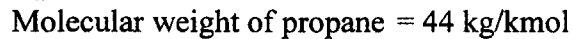
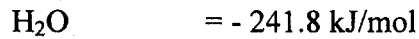
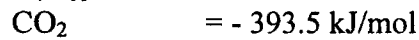
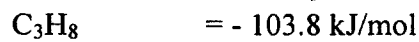

[18 marks]

4. [a] Huraikan dua kaedah yang selalu digunakan dalam industri proses untuk mencegah kebakaran dan letupan.

[7 markah]

- [b] Sebuah lori tangki membawa 700 kg propana dan 300 kg butana terlibat dalam satu kemalangan di kilometer 200 lebuh raya Utara-Selatan. Tangki lori itu pecah dan menghasilkan kepulan wap awan. Kepulan wap itu tercucuh 10 saat kemudian dan mengakibatkan satu letupan yang besar. Tentukan kesan tekanan lebih pada 500 m daripada punca letupan itu.

Data:

Lampiran A: Korelasi antara tekanan lebih dan jarak skala

Haba Pembentukan Standard, H_f°

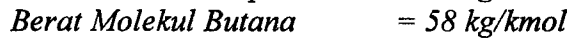
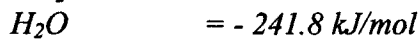
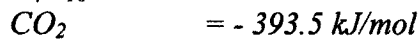
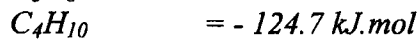

[18 markah]

...8/-

5. [a] Explain the meaning of the following words:

- [i] No
- [ii] More
- [iii] Less
- [iv] As well as
- [v] Reverse

[5 marks]

[b] Figure Q.5 [b] (Appendix B) shows Process Instrumentation Diagram of ammonia loading process from a tanker to a storage tank. Ammonia flows from the tanker to the storage tank due to pressure difference between the two points. Compressor is used to generate high pressure to the tanker. Perform HAZOP analysis for the line starting from tanker to the storage tank.

[20 marks]

5. [a] *Terangkan maksud perkataan-perkataan berikut:*

- [i] *Tidak*
- [ii] *Lebih*
- [iii] *Kurang*
- [iv] *Tambahan*
- [v] *Lawan*

[5 markah]

[b] *Gambarajah S.5 [b] (Lampiran B) menunjukkan Gambarajah Proses Instrumentasi bagi proses pengisian ammonia daripada lori tangki ke tangki simpanan. Ammonia mengalir daripada lori tangki ke tangki simpanan disebabkan oleh perbezaan tekanan daripada kedua-dua titik. Pemampat digunakan untuk menghasilkan tekanan tinggi kepada lori tangki. Jalankan analisis HAZOP untuk talian bermula daripada lori tangki ke tangki simpanan.*

[20 markah]

6. Figure Q.6 (Appendix C) shows Fault Tree Diagram for an accident from chlorohydrin reactor.

[a] Explain how the accident can occur starting from Level 1 to Level 4

[10 marks]

[b] Determine the probability for each gate and hence calculate the top probability for the accident to occur.

[15 marks]

6. *Gambarajah S. 6 (Lampiran C) menunjukkan gambarajah Pokok Kegagalan bagi satu kemalangan daripada reaktor klorohidrin.*

[a] *Terangkan bagaimana kemalangan boleh berlaku bermula dari Aras 1 ke Aras 4.*

[10 markah]

[b] *Tentukan kebarangkalian bagi setiap pintu dan seterusnya kirakan kebarangkalian teratas untuk kemalangan itu berlaku.*

[15 markah]

Appendix A

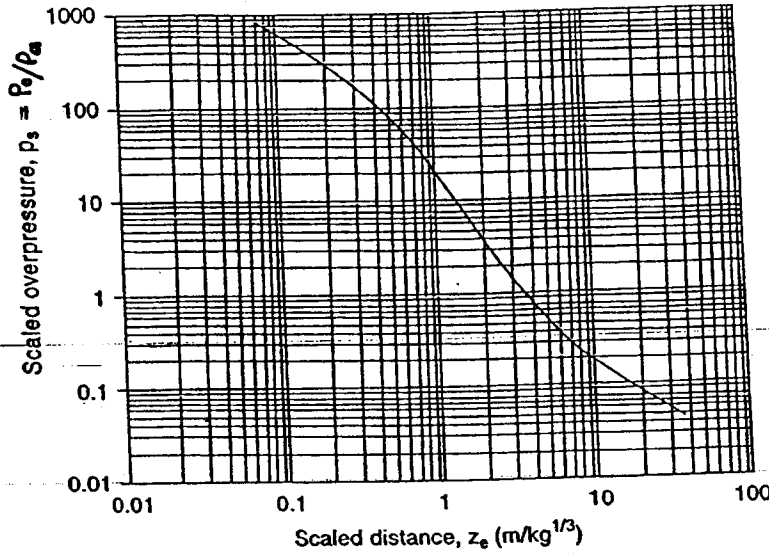

Correlation between overpressure and scaled distance

Table 6-9 Damage Estimates for Common Structures Based on Overpressure (these values are approximations)¹

$$\frac{P_o}{P_a} = \frac{1616 \left[1 + \left(\frac{z_e}{4.5} \right)^2 \right]^{1/2}}{\sqrt{1 + \left(\frac{z_e}{0.048} \right)^2} \sqrt{1 + \left(\frac{z_e}{0.32} \right)^2} \sqrt{1 + \left(\frac{z_e}{1.35} \right)^2}}$$

Pressure		Damage
psig	kPa	
0.02	0.14	Annoying noise (137 dB if of low frequency, 10-15 Hz)
0.03	0.21	Occasional breaking of large glass windows already under strain
0.04	0.28	Loud noise (143 dB), sonic boom, glass failure
0.1	0.69	Breakage of small windows under strain
0.15	1.03	Typical pressure for glass breakage
0.3	2.07	"Safe distance" (probability 0.95 of no serious damage below this value); projectile limit; some damage to house ceilings; 10% window glass broken
0.4	2.76	Limited minor structural damage
0.5-1.0	3.4-6.9	Large and small windows usually shatter; occasional damage to window frames
0.7	4.8	Minor damage to house structures
1.0	6.9	Partial demolition of houses, made uninhabitable
1-2	6.9-13.8	Corrugated asbestos shatters; corrugated steel or aluminum panels, fastenings fail, followed by buckling; wood panels (standard housing), fastenings fail, panels blow in
1.3	9.0	Steel frame of clad building slightly distorted
2	13.8	Partial collapse of walls and roofs of houses
2-3	13.8-20.7	Concrete or cinder block walls, not reinforced, shatter
2.3	15.8	Lower limit of serious structural damage
2.5	17.2	50% destruction of brickwork of houses
3	20.7	Heavy machines (3000 lb) in industrial buildings suffer little damage; steel frame buildings distort and pull away from foundations
3-4	20.7-27.6	Frameless, self-framing steel panel buildings demolished; rupture of oil storage tanks
4	27.6	Cladding of light industrial buildings ruptures
5	34.5	Wooden utility poles snap; tall hydraulic presses (40,000 lb) in buildings slightly damaged
5-7	34.5-48.2	Nearly complete destruction of houses
7	48.2	Loaded train wagons overturned
7-8	48.2-55.1	Brick panels, 8-12 in thick, not reinforced, fail by shearing or flexure
9	62.0	Loaded train boxcars completely demolished
10	68.9	Probable total destruction of buildings; heavy machine tools (7000 lb) moved and badly damaged, very heavy machine tools (12,000 lb) survive
300	2068	Limit of crater lip

¹V.I. Clancey, "Diagnostic Features of Explosion Damage," paper presented at the Sixth International Meeting of Forensic Sciences (Edinburgh, 1972).

Appendix B

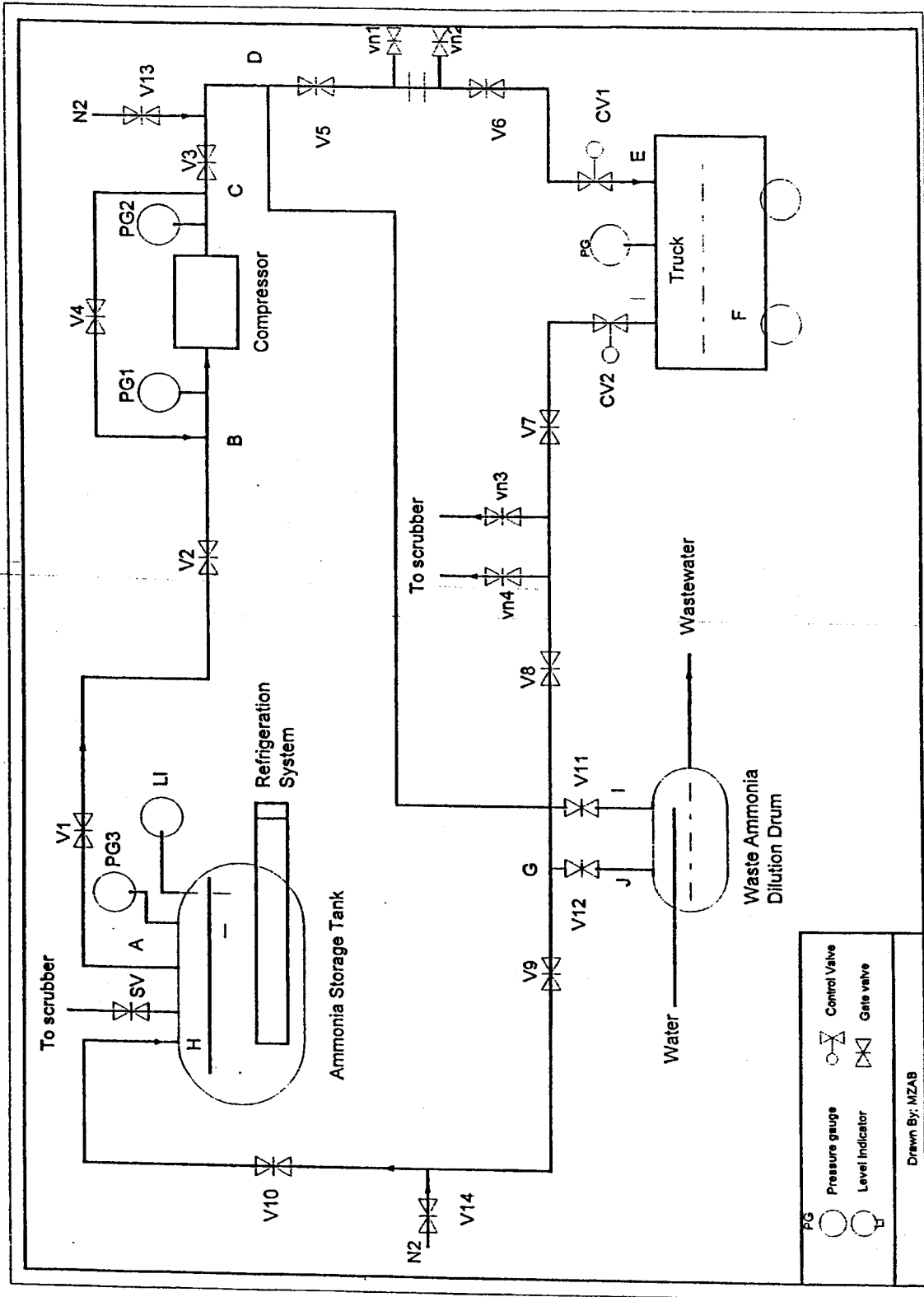

Figure Q. 5 [b]

Appendix C

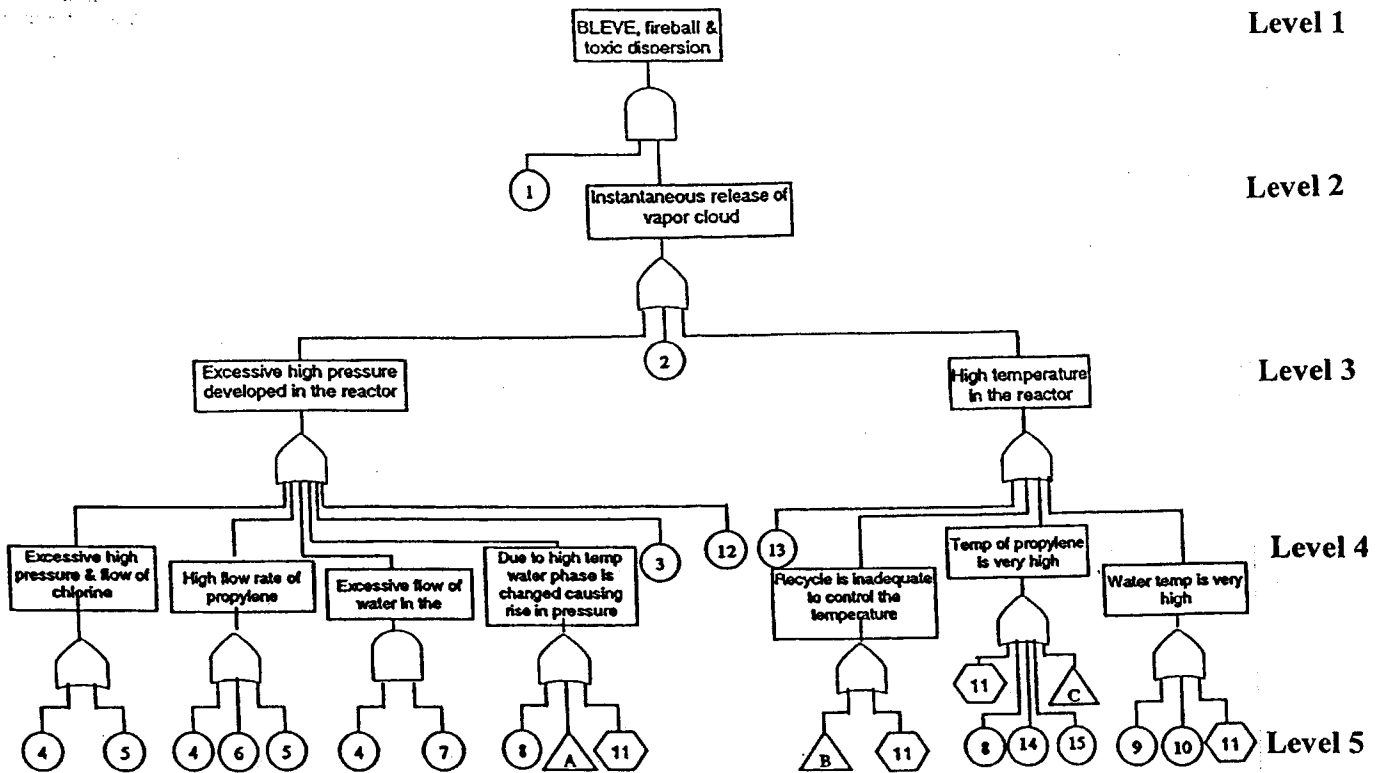

Figure Q. 6 Fault tree diagrams for an accident in chlorohydrin reactor

Elements of the fault tree developed for a probable accident in the chorohydrin reactor

Number referred in figure	Elements	Failure frequency (per year)
1	Ignition source	2.1E-01
2	Mechanical failure of the vessel	4.3E-05
3	Level controller fails	2.5E-01
4	Flow controller fails	2.5E-01
5	Over run of the pump	3.0E-02
6	High flow rate of the recycle stream	9.0E-02
7	High flow of water at up stream	9.0E-02
8	Temperature controller fails	2.0E-01
9	Upstream of propylene is high	1.7E-01
10	Heating medium flow rate in heater is high	1.7E-01
11	Flow rate is low	3.17E-01
12	Overfilling of the tank	1.5E-03
13	Uncontrolled side reaction	2.5E-01
14	Temperature of recycle stream is high	1.7E-01
15	High heat duty at exchanger E0117	1.44E-01
16	High flow rate of steam in kettle vaporizer	9.0E-02
17	Pressure of the steam in the vaporizer is high	1.7E-01

Details for event

A	5.29 E - 01
B	5.29 E - 01
C	4.84 E - 01