UNIVERSITI SAINS MALAYSIA

Semester II Examination
Academic Session 2004/2005

March 2005

**EEE 521 – COMPUTER AND DATA COMMUNICATIONS
NETWORKS**

Time : 3 hours

INSTRUCTION TO CANDIDATE:

Please ensure that this examination paper contains **SIX (6)** printed pages and **FIVE (5)** questions before answering.

Answer **ALL** questions.

Distribution of marks for each question is given accordingly.

All questions must be answered in English.

1. (a) Most communication are highly structured, having at least four layers (the Internet Protocol suite), and often as many as seven (e.g. the OSI Model).
 - (i) Explain the benefits of this high degree of structuring.
 - (ii) Describe the main issues which are addressed at each layer by protocols of the OSI model.
 - (iii) Compare and contrast the functions provided by the data link layer and the transport layer. Discuss the need for the replication of some functions in both these layers.
 - (iv) Some have said that OSI is dead. However, this is untrue. State two features of OSI which remain important issues, and explain why.

(12 marks)

- (b) With reference to the OSI model, discuss the following unified view of Layers, Protocols and Services (see Figure 1b).

(8 marks)

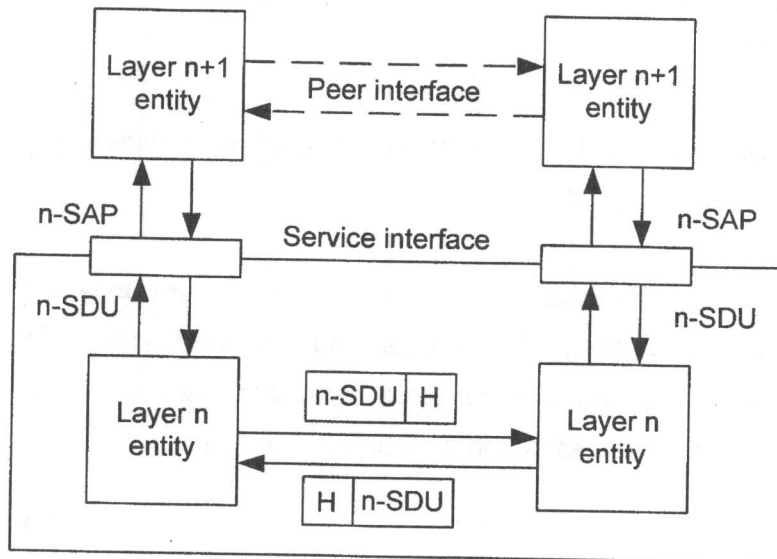

SDU = Service Data Unit
SAP = Service Access Point
H = SDU Header

Figure 1b

2. (a) Many computer protocols can be classified as *connection-oriented* and *connectionless*.
- (i) Discuss the differences between these two types of protocol and the types of service they give to their 'client'.
 - (ii) For each type, give two examples, with a brief justification, of application which would need that service.

(10 marks)

(b) Multiplexing involves sharing of transmission systems by several connections.

(i) Describe the time-division and frequency multiplexing processes (TDM and FDM).

(ii) What is a statistical multiplexer? Explain why they are so well-suited to terminal networks and illustrate how a TDM-based statistical can service more terminals than is implied by the number of timeslots on the outgoing network.

(10 marks)

3. (a) To meet the urgent need for standards for interconnect optical transmission systems, the Synchronous Optical Network (SONET) standard was established.

(i) How does SONET relate to TDM?

(ii) Discuss the SONET STS-1 frame structure in terms of the number of rows and column, their contents as well as the bit rate calculation.

(iii) The SONET standard defines the automatic protection switching (APS) scheme to provide linear protection against failures at the line layer. With the aid of a suitable block diagram, describe the APS 1+1 ("one plus one") scheme and 1:1 ("one for one") scheme.

(15 marks)

- (b) A protocol can be described in general terms as a set of rules and regulation agreed by two parties in order to communicate. Describe how the *HyperText Transfer Protocol* (HTTP) works.

(5 marks)

4. (a) Utilizing the Berkeley Socket *Application Programmer Interface* (API), show the flow chart of socket calls for *Connectionless Mode* between the client and server. State the socket functions involving socket (), bind (), sendto (), recvfrom (), and close ().

(5 marks)

- (b) Explain the following statements

- (i) Internetworking
- (ii) TCP and UDP provide universal communication services across the Internet.
- (iii) Domain Name System (DNS) protocol
- (iv) T1-carrier system transmission frame for telephone network.
- (v) The advantages of the Internet Protocol Version 6 (IPv6) over the Internet Protocol Version 4 (IPv4).

(15 marks)

5. (a) Describe type of Class A, B, C, and D addresses for classful addresses in TCP/IP protocol. Explain the differences of the classful addresses.

(5 marks)

(b) For the class A IP address 10.194.92.72 on a classful network with the subnet mask 255.255.240.0, determine the following:

- (i) IP address in binary
- (ii) Subnet address in binary
- (iii) Which bits are netids, subnetids, and hostids
- (iv) Network address
- (v) Subnetwork address

(5 marks)

(c) A circuit switch is a generalization of a physical cable in the sense that it provides connectivity that allows information to flow between inputs and outputs. Briefly, describe the two space division switches: the crossbar and the multistage switches.

(5 marks)

(d) Using a suitable diagram, describe the TCP 3 way handshake.

(5 marks)