

---

UNIVERSITI SAINS MALAYSIA

Second Semester Examination  
Academic Session 2009/2010

April/May 2010

**IWK 302 – Wood Engineering**  
***[Kejuruteraan Kayu]***

Duration: 3 hours  
*[Masa: 3 jam]*

---

Please check that this examination paper consists of FIFTEEN pages of printed material before you begin the examination.

*[Sila pastikan bahawa kertas peperiksaan ini mengandungi LIMA BELAS muka surat yang bercetak sebelum anda memulakan peperiksaan ini.]*

**Instructions:** Answer any **FIVE (5)** out of six questions. You may answer the question either in Bahasa Malaysia or in English.

**Arahan:** *Jawab mana-mana **LIMA (5)** daripada enam soalan. Anda dibenarkan menjawab soalan sama ada [untuk KBI] dalam Bahasa Malaysia atau Bahasa Inggeris.]*

In the event of any discrepancies, the English version shall be used.

*[Sekiranya terdapat sebarang percanggahan pada soalan peperiksaan, versi Bahasa Inggeris hendaklah diguna pakai].*

1. (a) Explain the stages involved in crack growth. (5 marks)

- (b) Based on Irwin-Kies Relationship and Figure 1, indicate that strain energy release rate (G) is

$$G = P_c^2 / 2B(dC/da),$$

where

- $P_c$  = Crack load
- $B$  = Thickness
- $C$  = Compliance
- $a$  = Crack length

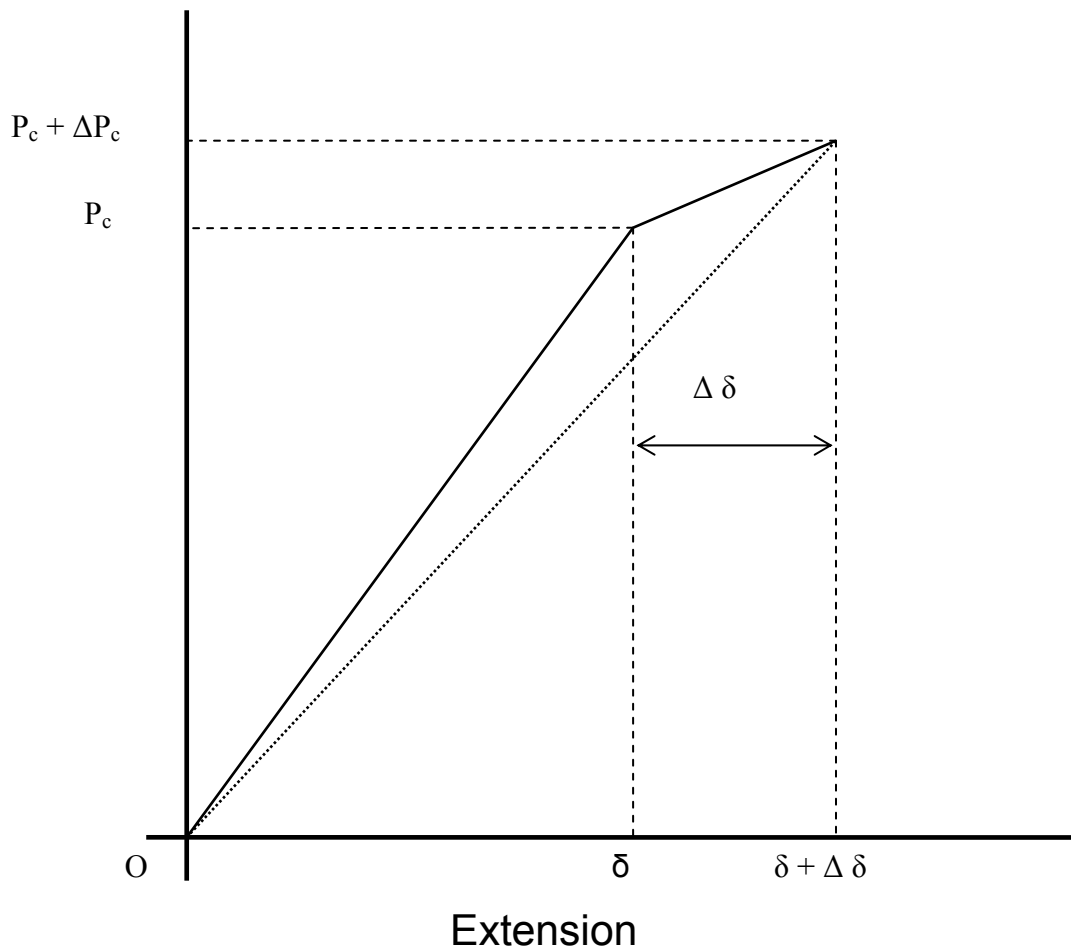

Figure 1

(15 marks)

...3/-

2. (a) For Figure 2, determine the following using integration method.

- (i) the area, A
- (ii) the centroid
- (iii) the moment of inertia,  $I_x$

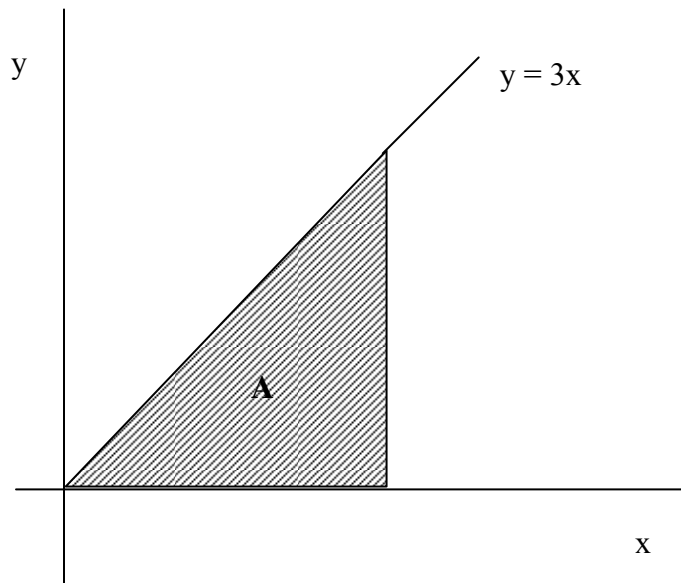

Figure 2

(10 marks)

(b) For the composite area shown in Figure 3, determine

- (i) the coordinate of the centroid
- (ii) the moment of inertia with respect to the x-axis,  $I_x$ .

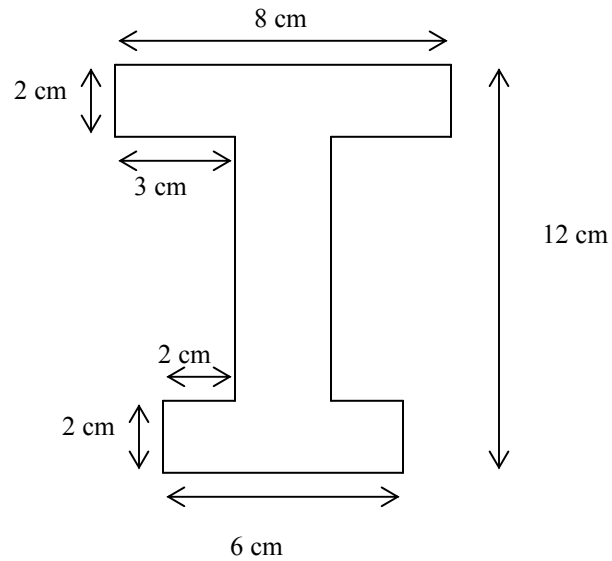

Figure 3

(10 marks)

3. A beam is loaded by a distributed force at its center as shown in Figure 4, the specifications of the beam are as follow;

$$\begin{aligned} F_{bo} &= 7500 \text{ kN/m}^2 \\ F_{vo} &= 850 \text{ kN/m}^2 \\ b &= 20 \text{ cm} \end{aligned}$$

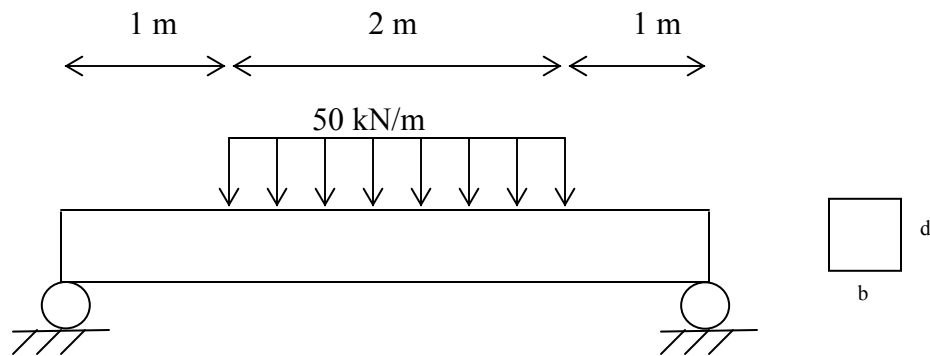

Figure 4

Determine the allowable minimum depth (d).

(20 marks)

4. A cantilever beam is loaded as shown in Figure 5. Indicate that the maximum deflection is  $PL^3/3EI$ , where;

P = load

L = length of the beam

E = modulus of elasticity

I = moment of inertia computed about the neutral axis

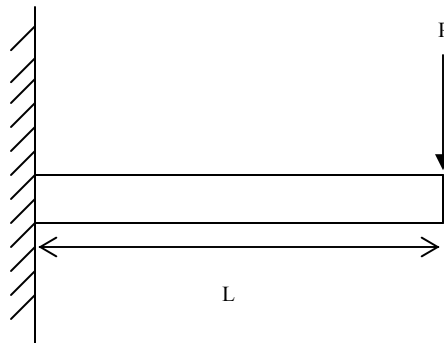

Figure 5

(20 marks)

5. A roof beam made of solid wood has the following specifications;

$C_d$  = 1.05 (load duration factor)

L = 16ft (length of the beam)

S = 2ft (space between beams)

$d_l$  = 20Ibf/ft<sup>2</sup> (dead load)

$l_l$  = 10 Ibf/ft<sup>2</sup> (live load)

$F_{bo}$  = 1600 Ibf/in<sup>2</sup> (allowable bending stress)

$F_{vo}$  = 750 Ibf/in<sup>2</sup> (allowable shear stress)

E = 1800000 Ibf/in<sup>2</sup> (modulus of elasticity)

$P_o$  = L/180 (allowable deflection)

Test the suitability of a section with size 1.5 in x 9.25 in.

(20 marks)

6. A two dimensional structure in Figure 6 has dimensions in arbitrary units. Using Finite Element Method, determine
- the displacement of each node
  - the reaction force at node 1, 3 and 4
  - the axial force in each element

| Element | E | A |
|---------|---|---|
| 12      | 1 | 1 |
| 23      | 1 | 1 |
| 24      | 1 | 1 |

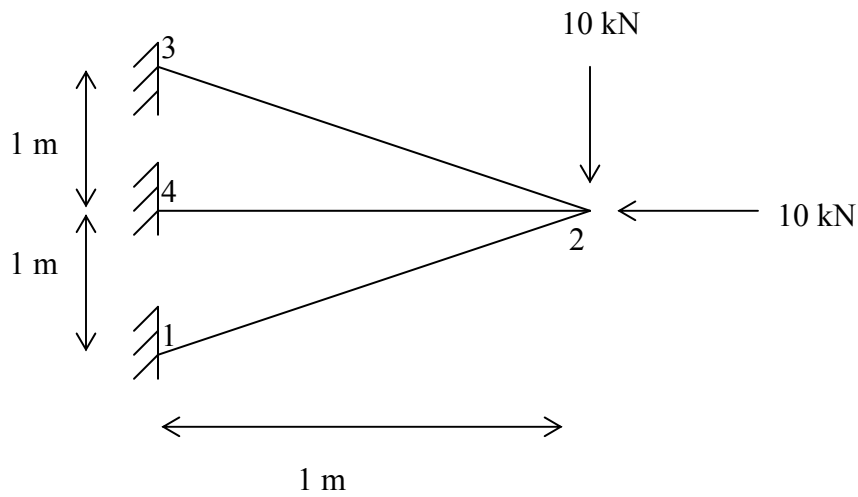

Figure 6

(20 marks)

## List of formulations

|       |                                      |
|-------|--------------------------------------|
| Z     | = $bd^2/6$ (section modulus)         |
| I     | = $bd^3/12$ (moment of inertia)      |
| $L_e$ | = $L - 2d$ (effective length)        |
| V     | = $wL_e/2$ (maximum shear force)     |
| M     | = $wL^2/8$ (maximum bending moment)  |
| $F_b$ | = $M/Z$ (actual bending stress)      |
| $F_v$ | = $3V/2A$ (actual shear stress)      |
| P     | = $5wL^4/384EI$ (actual deflection)  |
| $C_f$ | = $(12/d)^{1/9}$ (size factor)       |
| $C_c$ | = $1 - 2000 (t/R)^2$ (curve factor)  |
| $F_r$ | = $3M/2R_m A$ (actual radius stress) |



1. (a) Terangkan peringat-peringat yang terlibat dalam perebakan rekahan.  
(5 markah)
- (b) Berdasarkan hubungan Irwin-kies dan Rajah 1, tunjukkan bahawa kadar pembebasan tenaga terikan ( $G$ ) adalah diberikan oleh

$$G = P_c^2/2B(dC/da),$$

dengan

- $P_c$  = Beban rekahan  
 $B$  = Ketebalan  
 $C$  = Komplians  
 $a$  = Panjang retak

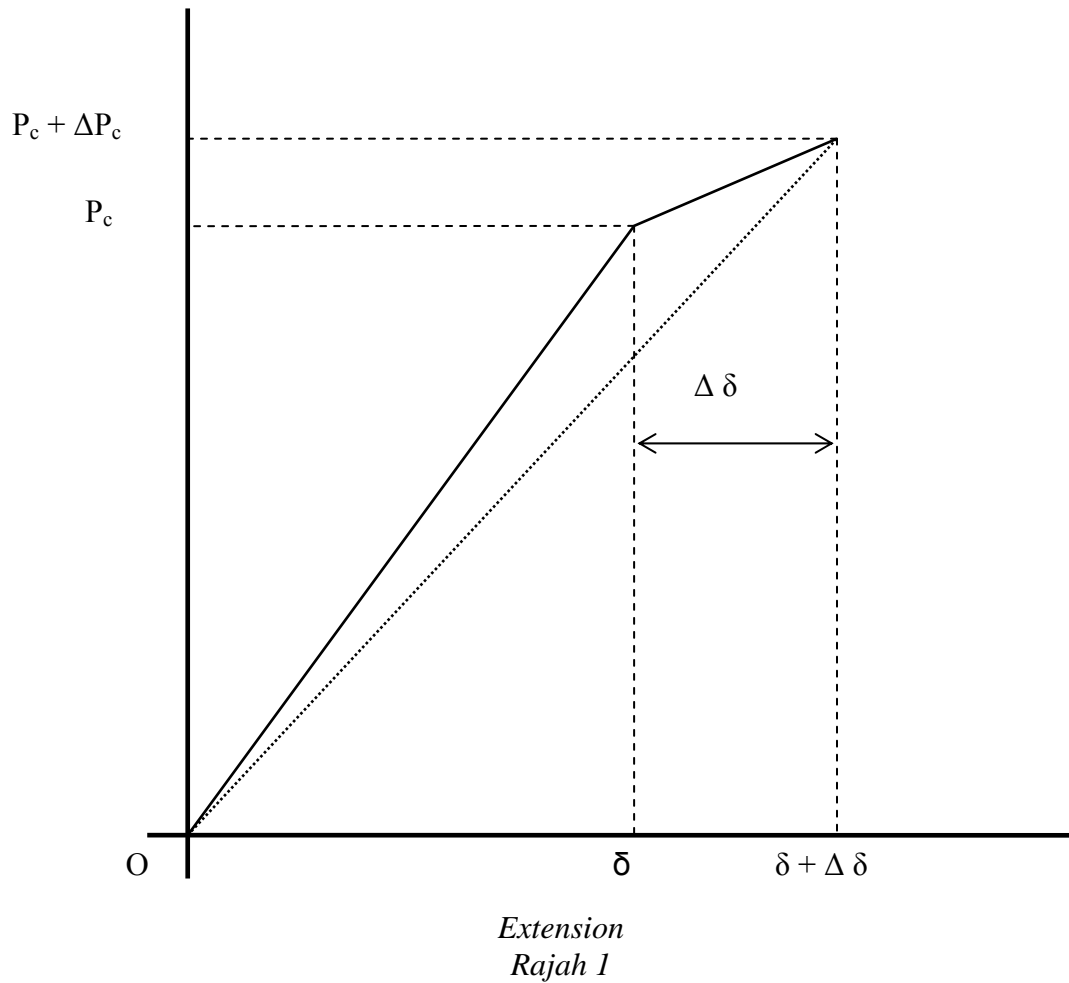

(15 markah)  
...10/-

2. (a) Untuk kawasan yang terlorek dalam Rajah 2, tentukan yang berikut dengan menggunakan kaedah pengamiran.
- (i) Keluasan kawasan terlorek,  $A$
  - (ii) Pusat bentuk
  - (iii) Momen inersia terhadap paksi  $x$ ,  $I_x$

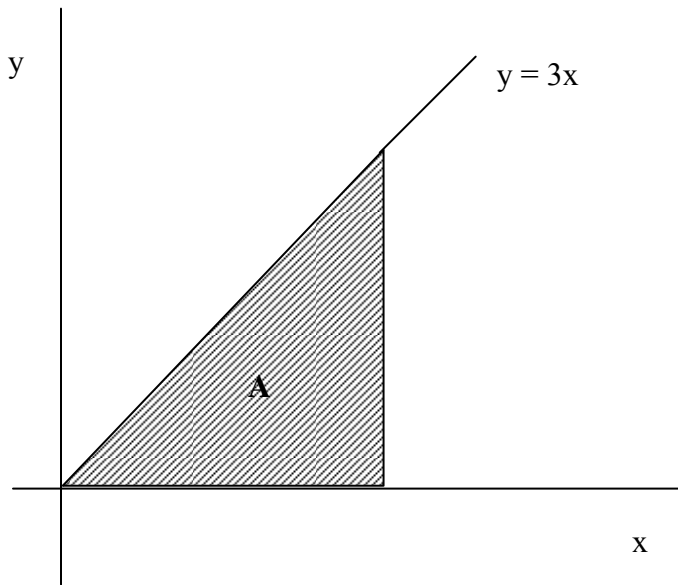

Rajah 2

(10 markah)

(b) Untuk rajah komposit yang ditunjukkan dalam Rajah 3, tentukan

- (i) Kordinat pusat bentuk
- (ii) Momen inersia terhadap paksi  $x$ ,  $I_x$ .

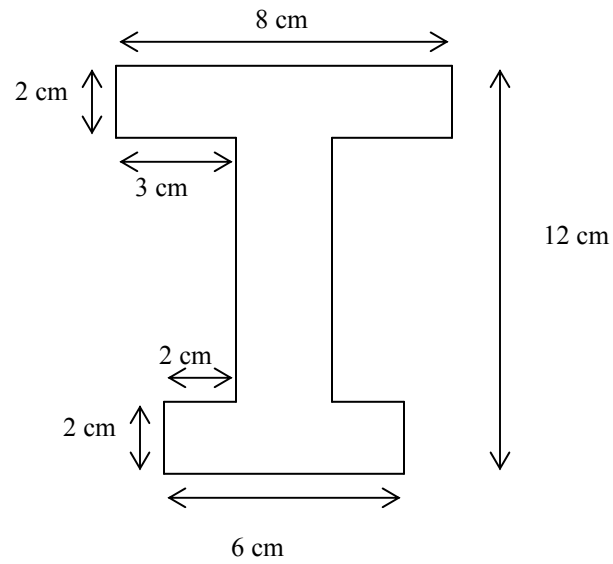

Rajah 3

(10 markah)

3. Suatu bim dibebankan dengan daya tertabur di bahagian tengahnya seperti yang ditunjukkan dalam Rajah 4 dan spesifikasi bim dalam seperti berikut

$$\begin{aligned} F_{bo} &= 7500 \text{ kN/m}^2 && \text{(tegasan lenturan izin)} \\ F_{vo} &= 850 \text{ kN/m}^2 && \text{(tegasan ricih izin)} \\ b &= 20 \text{ cm} && \text{(lebar bim)} \end{aligned}$$

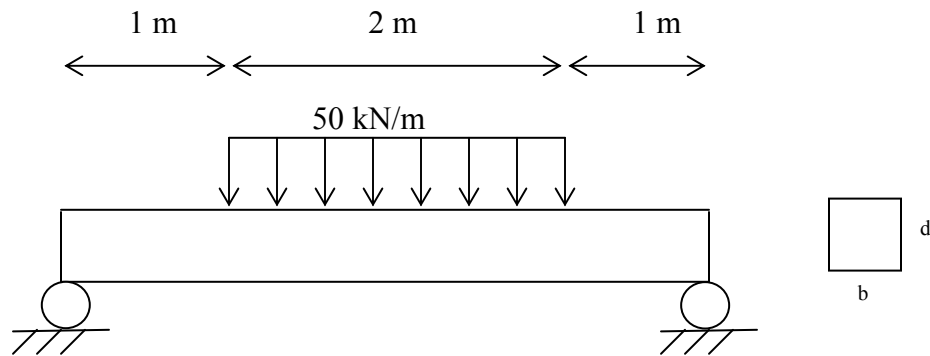

Rajah 4

Tentukan kedalaman/ketebalan ( $d$ ) minimum yang dibenarkan.

(20 markah)

4. Suatu bim kantilever dibebankan seperti yang ditunjukkan dalam Rajah 5. Tunjukkan pesongan maksimum bim tersebut adalah bersamaan dengan  $PL^3/3EI$ , dengan;

$P$  = Beban

$L$  = Panjang bim

$E$  = Modulus kekenyalan

$I$  = Moment inersia terhadap paksi neutral

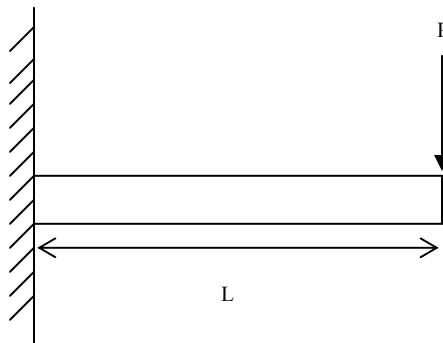

Rajah 5

(20 markah)

5. Suatu bim bumbung lurus yang diperbuat daripada kayu pejal mempunyai spesifikasi berikut;

$C_d$  = 1.05 (factor tempoh masa pengenalan beban)

$L$  = 16ft (panjang bim)

$S$  = 2ft (jarak antara bim)

$dl$  = 20Ibf/ft<sup>2</sup> (beban mati)

$ll$  = 10 Ibf/ft<sup>2</sup> (beban hidup)

$F_{bo}$  = 1600 Ibf/in<sup>2</sup> (tegasan lenturan izin)

$F_{vo}$  = 750 Ibf/in<sup>2</sup> (tegasan ricih izin)

$E$  = 1800000 Ibf/in<sup>2</sup> (modulus kekenyalan)

$P_o$  =  $L/180$  (pesongan izin)

Uji kesesuaian keratan yang bersaiz 1.5 in x 9.25 in

(20 markah)

6. Suatu struktur dua dimensi dalam Rajah 6 dengan ukurannya diberikan dalam unit sebarangan. Dengan menggunakan Kaedah Elemen Terhingga, tentukan

- (a) Sesaran setiap nod
- (b) Daya tindak balas pada nod 1, 3 and 4
- (c) Daya paksian setiap elemen

| <i>Elemen</i> | <i>E</i> | <i>A</i> |
|---------------|----------|----------|
| 12            | 1        | 1        |
| 23            | 1        | 1        |
| 24            | 1        | 1        |

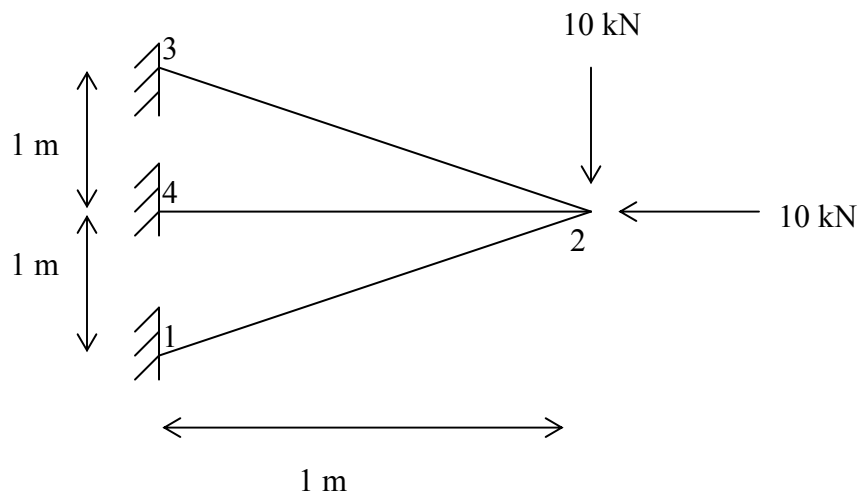

Rajah 6

(20 markah)

*Senarai formula*

|       |  |
|-------|--|
| $Z$   | $= bd^2/6$ (modulus keratan)             |
| $I$   | $= bd^3/12$ (momen inertia)              |
| $L_e$ | $= L - 2d$ (panjang berkesan)            |
| $V$   | $= wL_e/2$ (tegasan ricih maksimum)      |
| $M$   | $= wL^2/8$ (momen lenturan maksimum)     |
| $F_b$ | $= M/Z$ (tegasan lenturan sebenar)       |
| $F_v$ | $= 3V/2A$ (tegasan ricih sebenar)        |
| $P$   | $= 5wL^4/384EI$ (pesongan sebenar)       |
| $C_f$ | $= (12/d)^{1/9}$ (faktor saiz)           |
| $C_c$ | $= 1 - 2000 (t/R)^2$ (faktor lengkukan)  |
| $F_r$ | $= 3M/2R_m A$ (tegasan jejarian sebenar) |

