UNIVERSITI SAINS MALAYSIA

Second Semester Examination
2009/2010 Academic Session

April/May 2010

EAS 354/3 – Timber and Steel Structural Design [*Rekabentuk Struktur Kayu dan Keluli*]

Duration : 3 hours
[*Masa : 3 jam*]

Please check that this examination paper consists of **TWENTY ONE (21)** pages of printed material including appendices before you begin the examination.

[*Sila pastikan bahawa kertas peperiksaan ini mengandungi **DUA PULUH SATU (21)** muka surat yang bercetak termasuk lampiran sebelum anda memulakan peperiksaan ini.*]

Instructions : This paper contains **SIX (6)** questions. Answer **FIVE (5)** questions only. All questions carry the same marks.

[***Arahan** : Kertas ini mengandungi **ENAM (6)** soalan. Jawab **LIMA (5)** soalan sahaja. Semua soalan membawa jumlah markah yang sama.*]

You may answer the question either in Bahasa Malaysia or English.

[*Anda dibenarkan menjawab soalan sama ada dalam Bahasa Malaysia atau Bahasa Inggeris.*]

All questions **MUST BE** answered on a new page.

[*Semua soalan **MESTILAH** dijawab pada muka surat baru.*]

In the event of any discrepancies, the English version shall be used.

[*Sekiranya terdapat percanggahan pada soalan peperiksaan, versi Bahasa Inggeris hendaklah diguna pakai.*]

1. (a) Briefly describe factors that influence the strength of timbers.

[5 marks]

- (b) A solid timber column is designed to resist an axial load and moment. The strength group of column is SG4 in the dried condition. Both ends of the column is restrained in position but not in direction. Assuming the size of column is 100mm square with the actual height of 3.75m.

- i. Calculate the maximum axial long-term load that the column can support.

[5 marks]

- ii. Check the adequacy of the column to resist a long-term axial load of 10kN and bending moment of 350 kNm.

[10 marks]

2. (a) Distinguish between stress grading, strength group and permissible stress.

[5 marks]

- (b) A domestic dwelling of timber floor is shown in Figure 1. Using the following data design the timber floor joist.

Data : -

- The joists are spaced at 400 mm centres.
- The floor has an effective span of 4.0m.
- The flooring is tongue and groove boarding with self-weight of 0.1kN/m^2 .
- The ceiling is plasterboard with self-weight of 0.2 kN/m^2 .
- The timber is SG5/Moisture Content < 19%.

[15 marks]

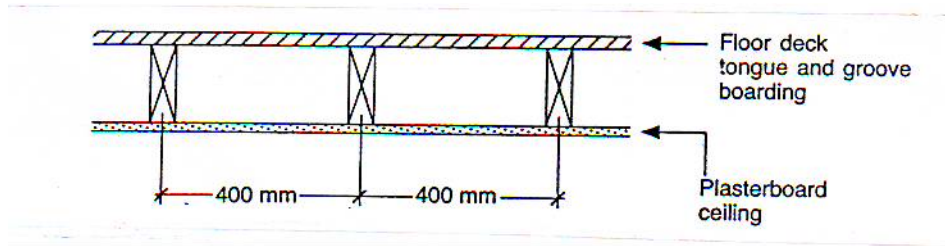

Figure 1

3. a) Discuss about the local buckling and section classification.

[6 marks]

- b) An unrestrained beam of 8 m span is subjected to three point loads which are not contributing to lateral restraint as shown in Figure 2. Check whether a 533 x 210 x 122 UB is adequate to withstand the lateral torsional buckling if the maximum moment subjected to the beam is 584.90 kNm. The shear capacity, bending capacity and deflection are assumed to be adequate. Refer to Appendix A.

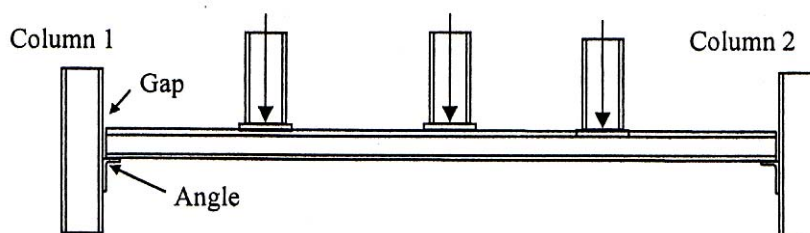

Figure 2

[14 marks]

4. A member of 356 x 368 x 153 UC classified as S275 is part of a braced multi-storey frame which has been shown to be non-sway. The storey height between beam centre is 6.0 m. The column is attached to the beams using flexible end plate connections and the beams support concrete floor slabs, thus providing partial restraint against bending in both principal planes and full restraint against rotation in plan. The axial load carry out by column is 1500 kN. The top column subjected to bending moment of 300 kNm about the major axis and 60 kNm about the minor axis. The bottom column subjected to bending moment of 200 kNm and 80 kNm, respectively (as shown in the bending moment diagrams in Figure 3). Check the adequacy of the column section for this storey. Refer to Appendix B.

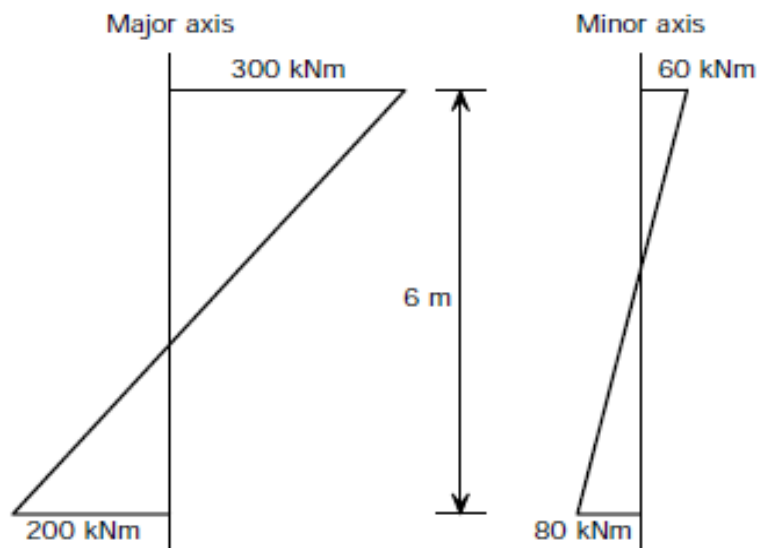

Figure 3

[20 marks]

5. a) The beam shown in Figure 4 is fastened to a much larger column using bolted connection. Two thick angles join the beam web to column flange. This question is about the adequacy of bolts therefore neglect all stresses in the angles and beam assuming they do not govern. The beam is 533 x 210 x 92 UB (Universal Beam) in grade S275 (with properties shown in Table 1. All bolts are 12 mm in diameter. Assume a hinged end condition (bolts not pre-tensioned) and therefore the connection is bearing type. Bolt grade is 4.6 with properties shown in Table 3. At the end of the beam, moment is 0 kNm and shear force is 300 kN, already factored. Determine the adequacy of bolts shown in Figure 4 and finally provide a summary of required design.

[10 marks]

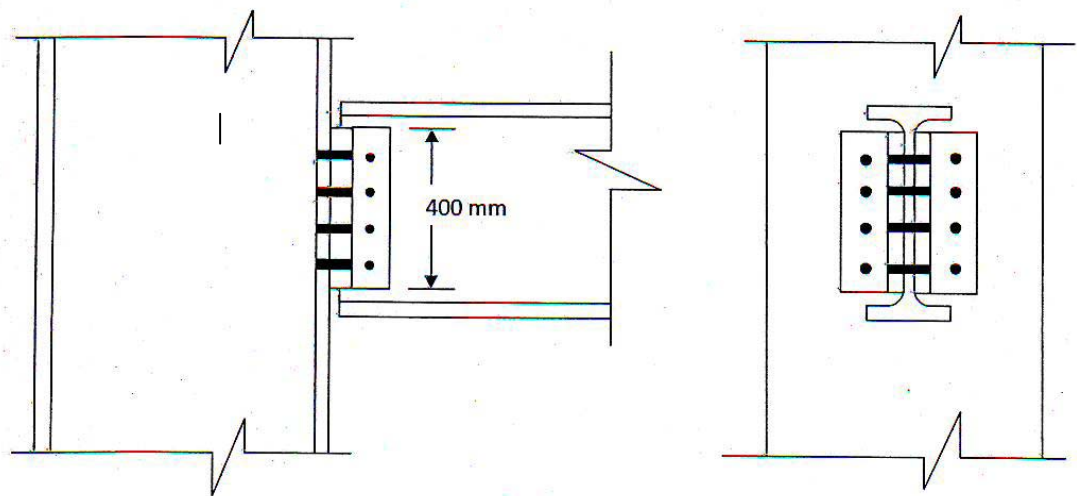

Figure 4

- b) The beam shown in Figure 5 is fastened to a much larger beam using fillet weld connection. Two thick angles join the beam web to the web of the larger beam. This question is about the adequacy of weld therefore neglect all stresses in the angles and beams assuming they do not govern. The smaller beam is 533 x 210 x 92 UB (Universal Beam) in grade S275 (with properties shown in Table 1). The weld is of Shield Metal Arc type and the electrode used is of E70XX type with maximum tensile strength of 450 kPa. Assume fixed end condition and fillet weld is used to join the webs with angles. Weld size is 2.0 cm, as shown in figure. At the end of the beam, moment is 600 kNm and shear force is 300 kN, both already factored. Determine the adequacy of weld shown in Fig. 4 and provide a summary of required design.

[10 marks]

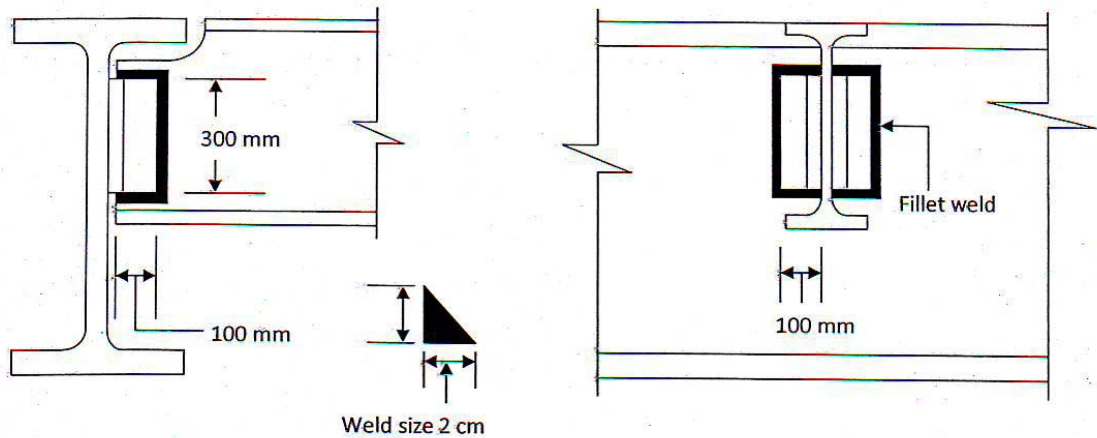

Figure 5

6. The frame of Figure 6 is a section from a standard truss system. You need to design members 1, 2, and 3, and bolted connection at A in order to support the given loads which consist of a 10 kN concentrated dead load and a 2 kN/m uniform live load. It has been decided that members 1, 2, and 3 to have the same equal angle section (in grade S275, from Table 4) and all connection bolts to have the same diameter (not pre-tensioned, Grade 4.6, from table 3). This question deals with adequacies of the top three members and connection bolts at A only therefore neglect all stresses in bottom members and connection steel plates assuming they do not govern.

(Note: $\lambda_{\text{maximum}} = 180$; for pinned ends, $L_e = L$; use most conservative curve in chart of Figure 7)

- a) Determine the required equal angle sections, citing all requirements. [10 marks]
- b) Determine the size and number of bolts required by each member in the connection at A. Present the details of the connection in a drawing. [10 marks]

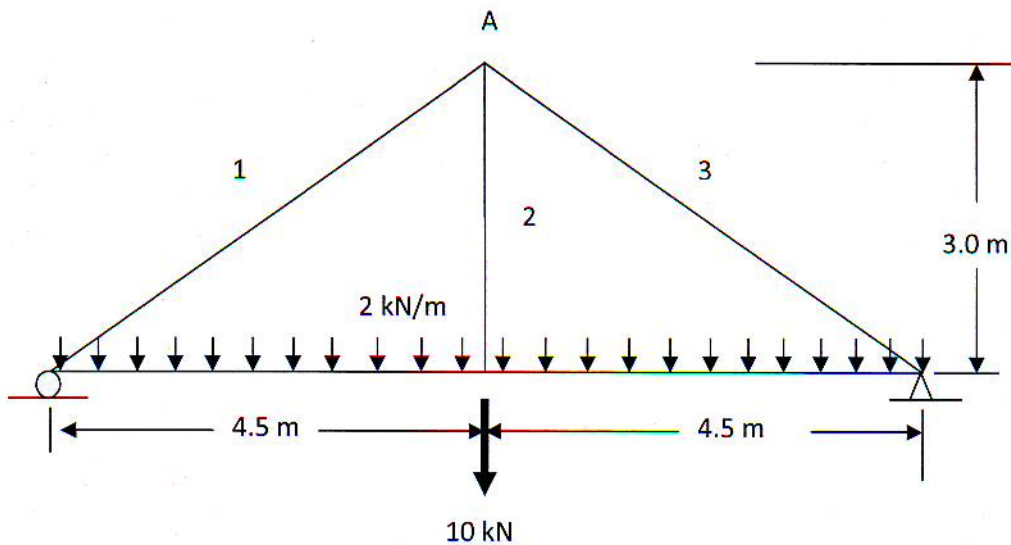

Figure 6

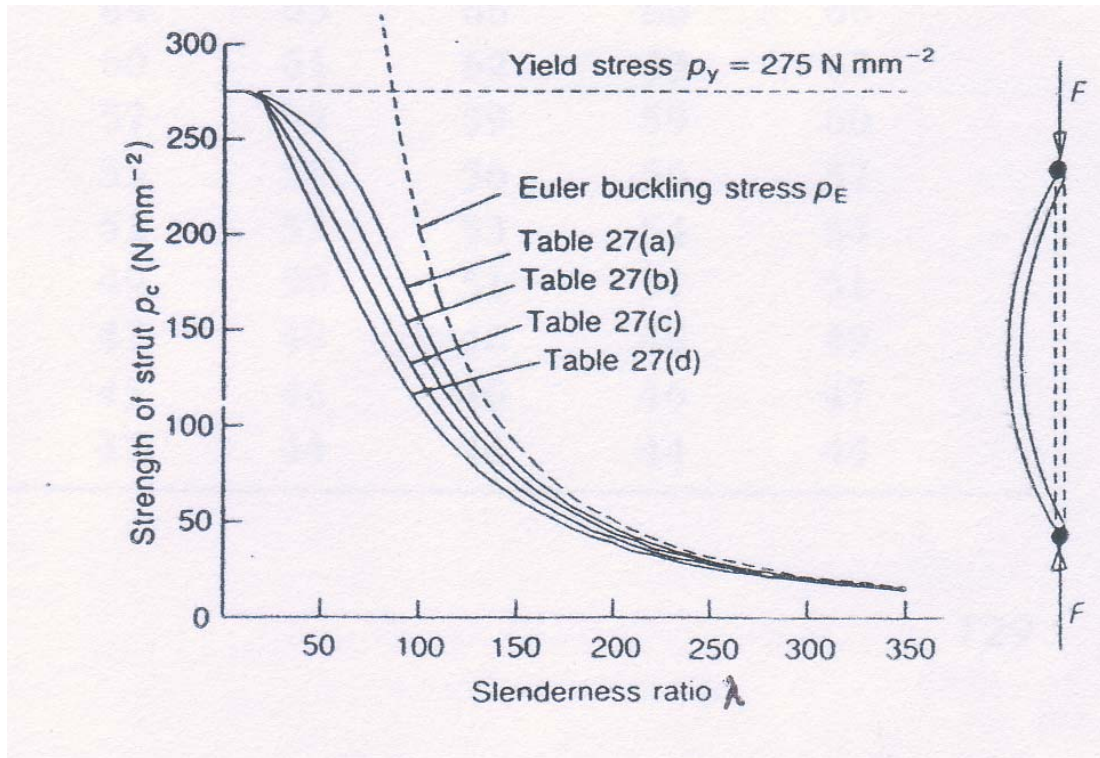

Figure 7

1. (a) *Terangkan dengan ringkas faktor-faktor yang mempengaruhi kekuatan kayu.*
[5 markah]

(b) *Satu anggota tiang kayu direkabentuk untuk merintang beban pugak dan momen. Kumpulan kekuatan bagi tiang ialah SG4 di dalam keadaan kering. Kedua-dua hujung tiang di kekang pada kedudukannya tetapi tidak dalam arah. Dengan menganggap saiz tiang 100mm segiempat sama dan ketinggian sebenar 3.75m.*

i. *Kirakan beban maksima pugak jangka panjang yang boleh ditanggung tiang.*

[5 markah]

ii. *Semak sama ada keupayaan tiang memadai untuk merintang beban pugak jangkapanjang sebesar 10 kN dan momen lentur, 350 kNm.*

[10 markah]

2. (a) *Bezakan di antara tegasan gred, kumpulan kekuatan dan tegasan izin.*
[5 markah]

(b) *Lantai kayu untuk sebuah rumah ditunjukkan dalam Rajah 1. Dengan menggunakan data berikut, rekabentuk gelegar lantai kayu tersebut,*

Data :-

- *Jarak luang gelegar 400mm pusat ke pusat.*
- *Jarak rentang lantai 4.0m.*
- *Berat sendiri lantai alur dan lidah 0.1 kN/m².*
- *Berat sendiri, kepingan siling 0.2 kN/m².*
- *Kumpulan kekuatan kayu, SG5 / kandungan lembapan < 19%.*

[15 markah]

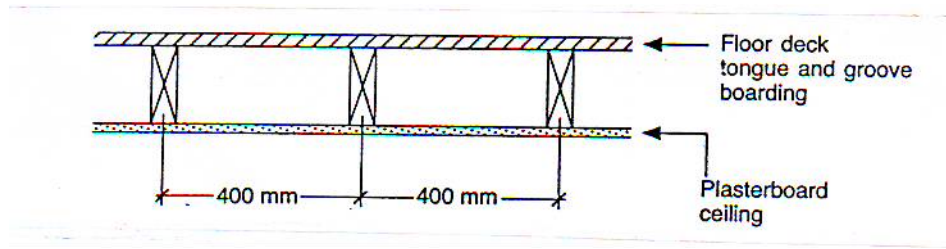

Rajah 1

3. a) Bincangkan tentang lengkukan tempatan dan pengelasan keratan.

[6 markah]

b) Satu keratan rasuk 8 m panjang dikenakan tiga beban tumpu yang mana tidak menyumbang kepada kekangan sisi seperti yang ditunjukkan dalam Gambarajah 2. Periksa samada keratan 533 x 210 x 122 UB adalah mencukupi bagi menanggung lengkukan kilasan sisi sekiranya momen maksimum yang dikenakan keatas rasuk adalah 584.90 kNm. Anggap keupayaan ricih, keupayaan lenturan, ada pesongan adalah mencukupi. Rujuk Lampiran A.

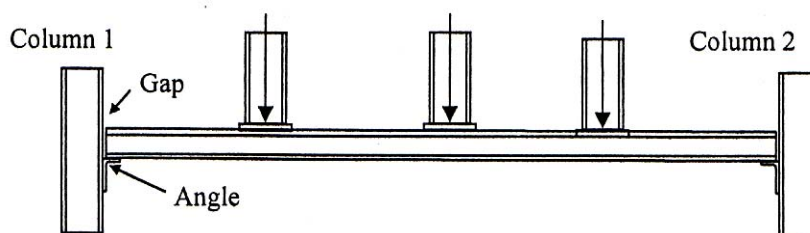

Rajah 2

[14 markah]

4. Satu keratan 356 x 368 x 153 UC diklasifikasikan sebagai S275 adalah sebahagian daripada kerangka bebilang tingkat yang dirembat yang tidak mengalami huyung. Ketinggian tingkat antara pusat ke pusat rasuk adalah 6.0 m. Tiang disambung kepada rasuk menggunakan 'flexible end plate connections' dan rasuk menanggung lantai papak konkrit, yang mana menyediakan kekangan separa melawan lenturan di kedua arah paksi utama serta kekangan penuh melawan putaran pada pandangan pelan. Beban paksi pada tiang adalah 1500 kN. Pada bahagian atas tiang momen adalah 300 kNm dalam arah paksi utama dan 60 kNm dalam arah paksi minor. Pada bahagian bawah tiang momen adalah 200 kNm and 80 kNm masing-masing (seperti yang ditunjukkan dalam gambarajah momen lentur dalam Gambarajah 3). Periksa kesesuaian keratan tiang untuk bangunan ini. Rujuk kepada Lampiran B.

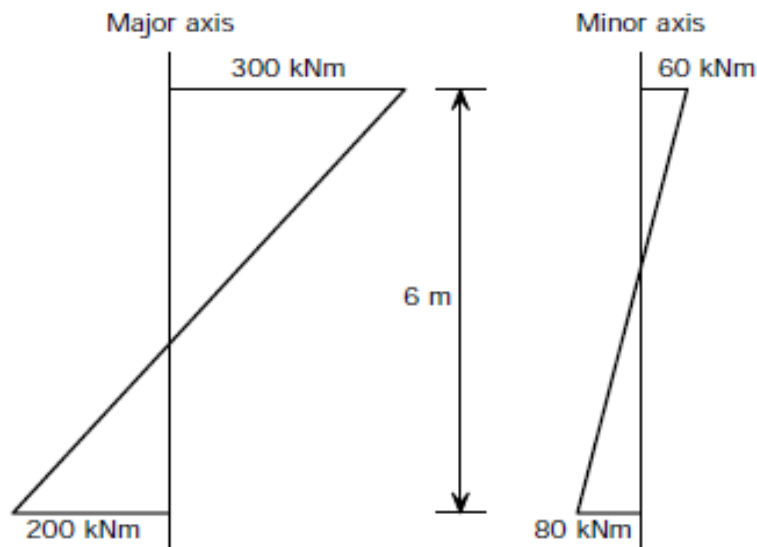

Rajah 3

[20 markah]

5. a) *Rasuk di Rajah 3 disambung kepada tiang besar menggunakan bolt. Dua keping plat sesiku menyambung web rasuk kepada bebibir tiang. Soalan ini berkaitan kecukupan bolt, dengan itu anggap komponen lain mencukupi. Rasuk 533 x 210 x 92 UB (Universal Beam) bergred S275 (data diberi di Jadual 1). Semua bolt bergarispusat 12 mm. Anggap hujung rasuk bebas, iaitu sambungan jenis galas. Bolt bergrade 4.6 (dengan datanya diberi di Jadual 1). Momen hujung rasuk 0 kNm dan daya ricih 300 kN, Faktor Keselamatan sudah diambilkira. Tentukan kecukupan bolt-bolt yang ditunjukkan di Rajah 3 dan akhirnya beri rekabentuk yang sebenarnya diperlukan*

[10 markah]

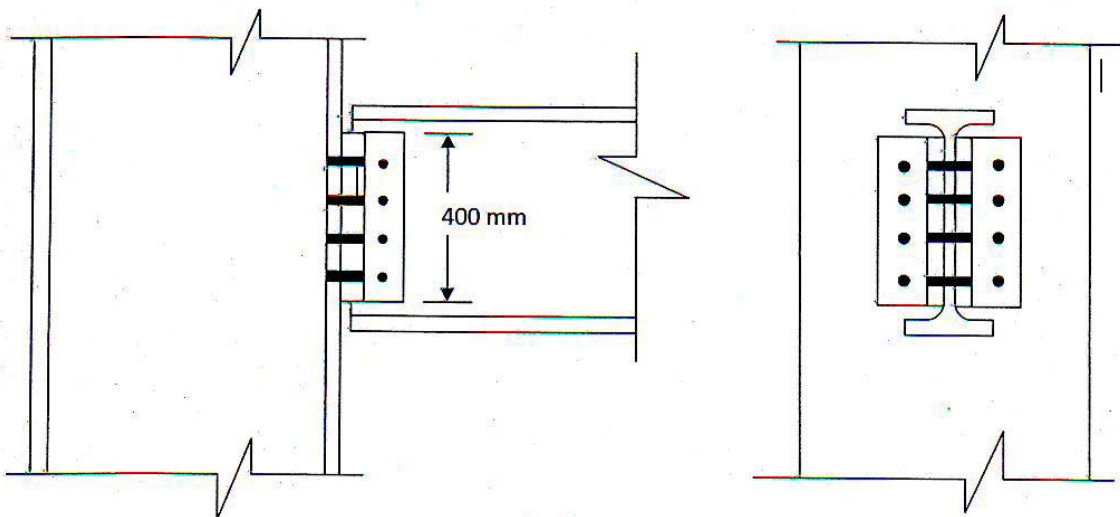

Rajah 4

- b) Rasuk di Rajah 4 dikimpal kepada rasuk besar. Dua keping plat sesiku menyambung web rasuk kecil kepada web rasuk besar. Soalan ini berkaitan kecukupan kimpal, dengan itu anggap komponen lain mencukupi. Rasuk kecil 533 x 210 x 92 UB (Universal Beam) bergred S275 (data diberi di Jadual 1). Kimpal dari jenis Shield Metal Arc dan elektrodnya dari jenis E70XX dengan kekuatan tegangan maksimum 450 kPa. Saiz kimpalan 2.0 cm, seperti ditunjukkan di rajah. Anggap hujung rasuk terikat, dan kimpal 'fillet' digunakan bagi menyambung bebibir dengan plat sesiku. Momen hujung rasuk 600 kNm dan daya ricih 300 kN, Faktor Keselamatan sudah diambilkira. Tentukan kecukupan kimpalan di Rajah 2 dan akhirnya beri rekabentuk yang sebenarnya diperlukan.

[10 markah]

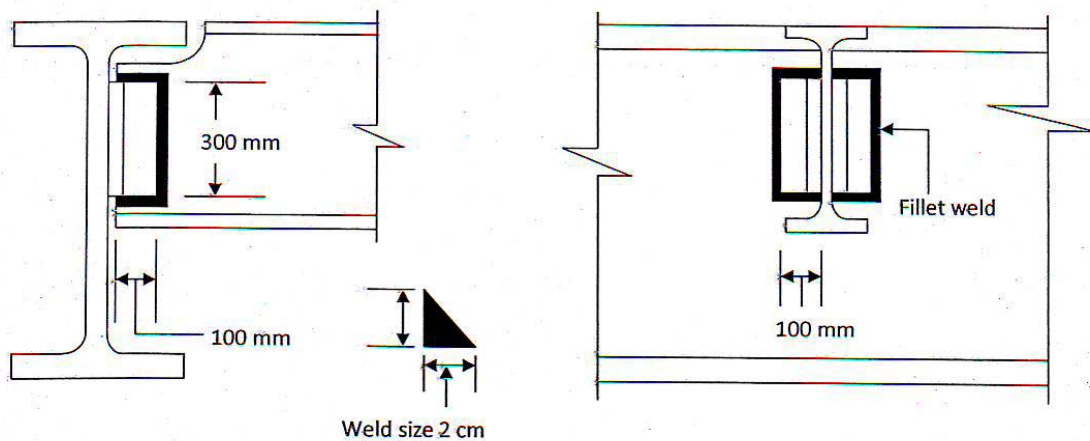

Rajah 5

6. Rajah 6 menunjukkan suatu bahagian daripada kekuda biasa. Anda dikehendaki memilih anggota 1, 2, dan 3, dan bolt bagi sambungan di A bagi menanggung bebanan diberi iaitu suatu bebanan mati tumpu 10 kN dan suatu beban keraan seragam 2 kN/m. Anggota 1, 2, dan 3, (dari gred S275, Jadual 4) dikehendaki mempunyai saiz yang sama begitu juga dengan semua bolt sambungan (tak-tertegas, Gred 4.6, Jadual 3), juga dikehendaki mempunyai saiz yang sama. Soalan ini mengenai cukup tidaknya saiz tiga anggota atas dan bolt-bolt di A, oleh itu abaikan semua tegasan pada anggota bawahan dan plet penyambung.

(Nota: $\lambda_{maksimum} = 180$; Bagi hujung berpilin, $L_e = L$; gunakan lengkung paling selamat di Rajah 7)

- a) Tentukan anggota sesiku yang sesuai, dengan memberi alasan rekabentuknya. ([10 markah])
- b) Tentukan saiz dan bilangan bolt yang diperlukan bagi setiap anggota pada sambungan di A dan lakarkan susun aturnya dengan jelas. [10 markah]

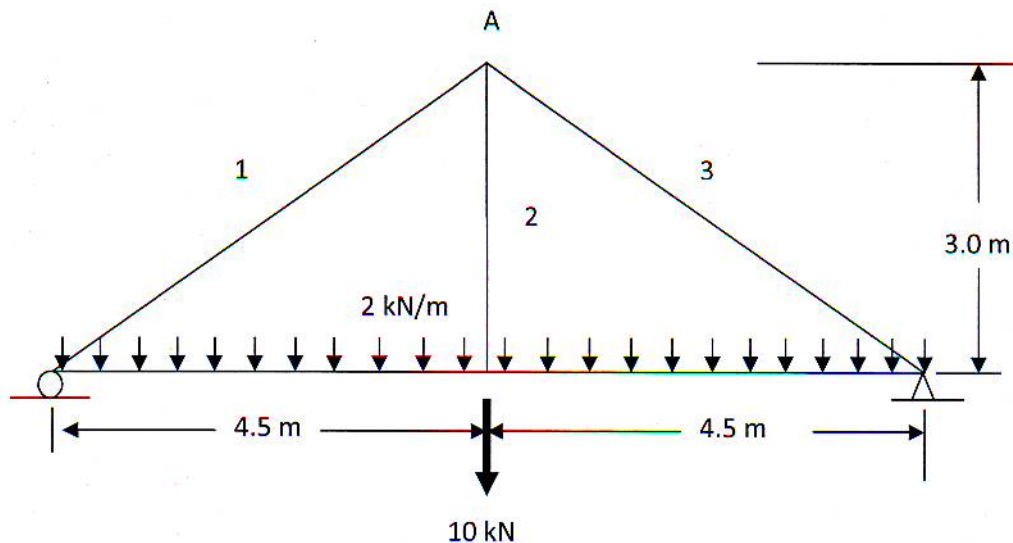

Rajah 6

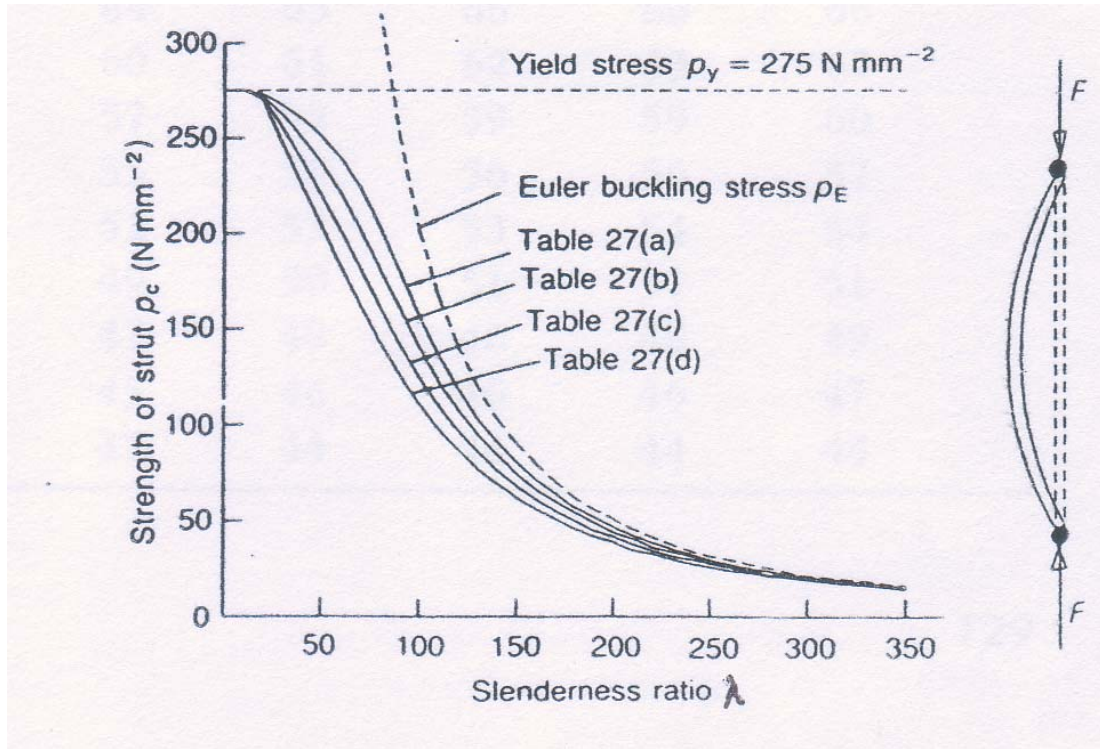

Rajah 7

APPENDIX A / LAMPIRAN A

BS 5950-1: 2000
BS 41: 1993

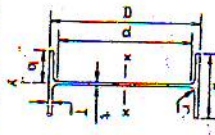

UNIVERSAL BEAMS

DIMENSIONS

PROPERTIES

Section Designation	Mass per Metre	Depth of Section	Width of Section	Thickness			Root Radius	Depth between Fillets	Radius for Local Buckling		Dimensions for Detailing		Second Moment of Area		Radius of Gyration		Elastic Modulus		Plastic Modulus		Buckling Parameter	Torsional Index	Warping Constant	Torsional Constant	Area of Section	
				Web	Flange	Flange			End Clearance	Notch	Axis	Axis	Axis	Axis	Axis	Axis	Axis	Axis	Axis	Axis						Axis
	kg/m	mm	mm	mm	mm	mm	mm	mm	b/T	d/T	mm	mm	mm	mm	mm	mm	mm	mm	mm	mm	mm	mm	mm	mm	mm	mm
1016x305x437	486.8	1036.1	308.5	30	54.1	30	897.9	2.85	28.9	17	150	86	26700	26700	40.8	6.57	19700	1730	23200	2800	0.867	21.1	64.4	4300	620	
1016x305x437	436.9	1025.9	305.4	26.9	49	30	897.9	3.12	32.3	16	150	80	91000	23500	40.4	6.49	17700	1540	20800	2470	0.868	23.1	55.9	4300	620	
1016x305x393	392.7	1016	303	24.4	43.9	30	868.2	3.45	35.6	14	150	74	808000	20500	40.2	6.4	15900	1350	18500	2170	0.868	25.5	46.4	3190	557	
1016x305x349	349.4	1008.1	302	21.1	40	30	868.1	3.77	41.1	13	150	70	729000	18500	40.3	6.44	14400	1220	16600	1940	0.872	27.9	43.3	1720	500	
1016x305x314	314.3	1000	300	19.1	35.9	30	868.2	4.18	45.5	12	150	66	644000	16200	40.1	6.37	12900	1080	14900	1710	0.872	30.7	37.7	1260	445	
1016x305x272	272.3	990.1	300	16.5	31	30	868.1	4.84	52.6	10	152	63	554000	14000	40	6.35	11200	934	12800	1470	0.872	35	32.2	835	347	
1016x305x249	248.7	980.2	300	16.5	28	30	868.2	5.77	52.6	10	152	56	481000	11800	39	6.09	9820	784	11400	1250	0.881	39.9	28.8	582	317	
1016x305x222	222	970.3	300	16	21.1	30	868.1	7.11	54.3	10	152	52	408000	9550	38	5.81	8410	636	9810	1020	0.849	45.8	21.5	390	283	
914x193x988	388	921	420.5	21.4	36.8	24.1	799.8	5.74	37.4	13	210	82	720000	45400	38.2	9.59	15800	2760	17700	3340	0.885	26.7	88.9	1730	437	
914x193x843	343.3	911.8	418.5	19.4	32	24.1	799.8	6.54	41.2	12	210	58	629000	39200	37.8	9.46	13700	1870	15500	2890	0.883	30.1	75.8	1190	437	
914x305x289	289.1	928.8	307.7	19.5	32	19.1	824.4	4.81	42.3	12	156	52	504000	15800	37	6.51	10900	1010	12600	1800	0.867	31.9	31.2	928	368	
914x305x253	253.4	918.4	305.5	17.3	27.9	19.1	824.4	5.47	47.7	11	156	48	436000	13300	36.8	6.42	9500	871	10900	1370	0.865	36.2	28.4	626	323	
914x305x224	224.2	910.4	304.1	15.9	23.9	19.1	824.4	6.36	51.8	10	156	44	376000	11200	36.3	6.27	8270	739	9540	1160	0.861	41.3	22.1	422	286	
914x305x201	200.9	903	303.3	15.1	20.2	19.1	824.4	7.51	54.9	10	156	40	325000	9420	35.7	6.07	7200	621	8350	982	0.853	46.9	18.4	291	256	
838x292x226	226.5	850.9	293.8	16.1	28.8	17.8	761.7	5.48	47.3	10	150	46	340000	11400	34.3	6.27	7990	773	11700	1340	0.869	35	19.3	514	269	
838x292x194	193.8	840.7	292.4	14.7	21.7	17.8	761.7	6.74	51.8	8	150	40	279000	9070	33.6	6.06	6640	620	7640	974	0.862	41.8	15.2	247	224	
838x292x176	175.9	834.9	291.7	14	18.8	17.8	761.7	7.76	54.4	9	150	38	246000	7800	33.1	5.9	5890	535	6810	842	0.856	48.5	13	221	224	
762x267x197	196.8	769.8	268	15.6	25.4	16.5	686	5.28	44	10	138	42	240000	8180	30.9	5.71	6230	610	7170	959	0.868	33.2	11.3	404	251	
762x267x173	173	762.2	266.7	14.3	21.6	16.5	686	6.17	48	9	138	40	205000	6850	30.5	5.58	5390	514	6200	807	0.865	38.1	9.39	267	220	
762x267x147	146.9	754	265.2	12.8	17.5	16.5	686	7.58	53.6	8	138	34	169000	5460	30	5.4	4470	411	5160	647	0.858	45.2	7.4	159	167	
762x267x134	133.9	750	264.4	12	15.5	16.5	686	8.53	57.2	8	138	32	151000	4790	29.7	5.3	4020	392	4640	570	0.853	49.8	6.46	119	171	
688x254x170	170.2	692.9	255.8	14.5	23.7	15.2	615.1	5.4	42.4	9	132	40	170000	6630	28	5.53	4820	518	5630	811	0.872	31.8	7.42	308	217	
688x254x152	152.4	687.5	254.5	13.2	21	15.2	615.1	6.08	46.6	9	132	38	150000	5780	27.8	5.46	4370	455	5000	647	0.871	35.4	6.42	220	194	
688x254x140	140.1	683.5	253.7	12.4	19	15.2	615.1	6.88	49.6	8	132	36	136000	5180	27.6	5.39	3990	408	4580	636	0.869	38.6	5.72	169	178	
688x254x125	125.2	677.9	253	11.7	16.2	15.2	615.1	7.81	52.8	8	132	32	118000	4380	27.2	5.24	3480	348	3990	542	0.863	43.8	4.8	116	159	
610x305x238	238.1	635.8	311.4	18.4	31.4	16.5	540	4.96	29.3	11	158	48	210000	15800	28.3	7.23	6590	743	7490	1570	0.887	21.3	14.5	785	303	
610x305x179	179	620.2	307.1	14.1	23.6	16.5	540	6.51	38.3	9	158	48	153000	11460	25.9	7.07	4940	610	5550	1140	0.868	27.7	10.2	340	303	
610x305x149	149.2	612.4	304.8	11.8	19.7	16.5	540	7.74	45.9	8	158	38	129000	9310	25.7	7	4110	410	4590	937	0.866	32.7	8.17	200	190	
610x229x140	139.9	617.2	230.2	13.1	22.1	12.7	547.6	5.21	41.8	9	120	36	112000	4570	25	5.03	3620	391	4140	811	0.875	30.6	3.99	178	178	
610x229x125	125.1	612.2	229	11.9	19.6	12.7	547.6	5.84	46	8	120	34	98600	3930	24.6	4.87	3220	343	3680	535	0.874	34.1	3.45	154	159	
610x229x113	113	607.6	228.2	11.1	17.3	12.7	547.6	6.8	48.3	8	120	30	87300	3430	24.6	4.88	2870	301	3280	468	0.87	36.1	2.99	111	144	
610x229x101	101.2	602.6	227.6	10.5	14.8	12.7	547.6	7.89	52.2	7	120	28	75800	2920	24.2	4.75	2520	258	2880	400	0.863	43.1	2.52	77	129	
533x210x122	122	544.5	211.8	12.7	21.3	12.7	476.5	4.97	37.5	8	110	34	78000	3390	22.1	4.67	2790	320	3200	500	0.878	27.6	2.32	178	155	
533x210x109	109	539.5	210.8	11.8	18.8	12.7	476.5	5.61	41.1	8	110	32	68600	2940	21.9	4.6	2480	279	2890	436	0.874	31	1.99	126	139	
533x210x101	101	536.7	210	10.8	17.4	12.7	476.5	6.03	44.1	7	110	30	61500	2690	21.9	4.57	2290	256	2610	399	0.873	33.2	1.81	101	129	
533x210x92	92.1	533.1	208.3	10.1	15.8	12.7	476.5	6.71	47.2	7	110	30	55200	2390	21.7	4.51	2070	228	2360	358	0.873	38.4	1.6	75.7	117	
533x210x82	82.2	528.3	208.8	9.6	13.2	12.7	476.5	7.81	49.6	7	110	26	47500	2010	21.3	4.36	1800	192	2060	300	0.863	41.6	1.33	51.5	105	

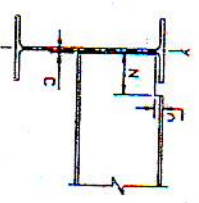

APPENDIX B / LAMPIRAN B

UNIVERSAL COLUMNS -- DIMENSIONS AND PROPERTIES
o BS 4: Part 1: 1980

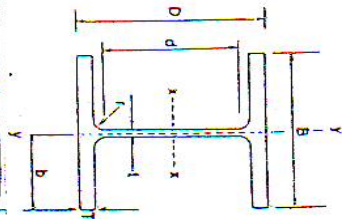

Designation	Depth of Section D	Width of Section B	Thickness		Root Radius r	Web Flange Ratio b/T	Web d/t	Second Moment of Area		Radius of gyration		Elastic modulus		Plastic modulus		Buckling Parameter u	Torsional Index x	Warping Constant H	Torsional Constant J	Area of Section	
			Web T	Flange T				Axis X-X	Axis Y-Y	Axis X-X	Axis Y-Y	Axis X-X	Axis Y-Y	Axis X-X	Axis Y-Y						
356 x 406	474.7	424.1	47.6	77.0	15.2	290.1	2.75	6.10	275140	98211	18.5	11.0	11592	4632	14247	7114	0.843	5.46	38.8	13700	808.1
	455.7	418.5	42.0	67.5	15.2	290.1	3.10	6.91	227023	82665	18.0	10.9	9964	3951	12078	6058	0.841	6.05	31.1	9240	701.8
	436.6	412.4	35.9	56.0	15.2	290.1	3.56	8.08	183118	67905	17.5	10.7	8388	3293	10009	5038	0.839	6.86	24.3	5620	595.5
	419.1	407.0	30.6	49.2	15.2	290.1	4.14	9.48	146765	55410	17.1	10.5	7004	2723	8229	4157	0.837	7.86	19.0	3550	500.9
	406.4	403.0	26.5	42.9	15.2	290.1	4.70	11.0	122474	46816	16.8	10.4	6027	2324	6994	3541	0.836	8.85	15.5	2340	432.7
	393.7	399.0	22.6	36.5	15.2	290.1	5.47	12.8	99994	38714	16.5	10.3	5080	1940	5818	2952	0.835	10.2	12.3	1440	366.0
	381.0	395.0	18.5	30.2	15.2	290.1	6.54	15.7	79110	31008	16.2	10.2	4153	1570	4689	2384	0.834	12.1	9.54	812	299.8
356 x 368	374.7	374.4	16.8	27.0	15.2	290.1	6.93	17.3	66307	23632	16.0	9.57	3540	1262	3977	1917	0.844	13.3	7.14	560	237.9
	368.3	372.1	14.5	23.8	15.2	290.1	7.82	20.0	57153	20470	15.9	9.52	3104	1100	3457	1668	0.844	15.0	6.07	383	225.7
	362.0	370.2	12.5	20.7	15.2	290.1	8.94	23.0	48525	17469	15.8	9.46	2681	943.8	2964	1430	0.844	17.0	5.09	251	195.2
	355.6	368.3	10.7	17.5	15.2	290.1	10.5	27.1	40246	14555	15.6	9.39	2264	790.4	2462	1196	0.843	19.9	4.16	153	164.9
305 x 305	365.3	321.8	25.9	44.1	15.2	246.6	3.65	9.17	78777	24545	14.8	8.25	4314	1525	5101	2337	0.855	7.65	6.33	2030	360.4
	352.6	317.9	23.0	37.7	15.2	246.6	4.22	10.7	64177	20239	14.5	8.14	3641	1273	4245	1947	0.854	8.73	5.01	1270	305.6
	339.9	314.1	19.2	31.4	15.2	246.6	5.00	12.8	50832	16230	14.2	8.02	2991	1034	3456	1576	0.854	10.2	3.86	734	252.3
	327.2	310.6	15.7	25.0	15.2	246.6	6.21	15.7	38740	12524	13.9	7.89	2368	806.3	2680	1228	0.852	12.5	2.86	379	201.2
	320.5	308.7	13.8	21.7	15.2	246.6	7.11	17.9	32838	10672	13.7	7.82	2049	691.4	2298	1052	0.851	14.1	2.38	250	174.6
	314.5	306.8	11.9	18.7	15.2	246.6	8.20	20.7	27601	9006	13.6	7.75	1755	567.0	1953	891.7	0.851	16.2	1.97	160	149.8
	307.8	304.8	9.9	15.4	15.2	246.6	9.90	24.9	22202	7268	13.4	7.68	1442	476.9	1589	723.5	0.850	19.3	1.55	91.1	123.3

TABLE 1 / JADUAL 1

UNIVERSAL BEAMS

BS 5950-1: 2000
BS 4-1: 1993

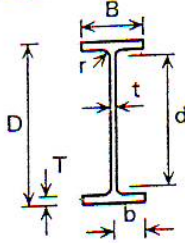
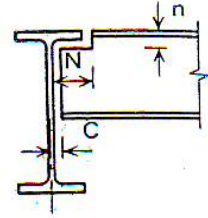

Table 1

DIMENSIONS



Section Designation	Mass per Metre kg/m	Depth of Section D mm	Width of Section B mm	Thickness		Root Radius r mm	Depth between Fillets d mm	Ratios for Local Buckling		Dimensions for Detailing			Surface Area	
				Web t mm	Flange T mm			Flange b/T	Web d/t	End Clearance C mm	Notch		Per Metre m ²	Per Tonne m ²
											N mm	n mm		
1016x305x487 # +	486.6	1036.1	308.5	30.0	54.1	30.0	867.9	2.85	28.9	17	150	86	3.19	6.57
1016x305x437 # +	436.9	1025.9	305.4	26.9	49.0	30.0	867.9	3.12	32.3	16	150	80	3.17	7.25
1016x305x393 # +	392.7	1016.0	303.0	24.4	43.9	30.0	868.2	3.45	35.6	14	150	74	3.14	8.01
1016x305x349 # +	349.4	1008.1	302.0	21.1	40.0	30.0	868.1	3.77	41.1	13	150	70	3.13	8.96
1016x305x314 # +	314.3	1000.0	300.0	19.1	35.9	30.0	868.2	4.18	45.5	12	150	66	3.11	9.90
1016x305x272 # +	272.3	990.1	300.0	16.5	31.0	30.0	868.1	4.84	52.6	10	152	63	3.10	11.4
1016x305x249 # +	248.7	980.2	300.0	16.5	26.0	30.0	868.2	5.77	52.6	10	152	56	3.08	12.4
1016x305x222 # +	222.0	970.3	300.0	16.0	21.1	30.0	868.1	7.11	54.3	10	152	52	3.06	13.8
914x419x388 #	388.0	921.0	420.5	21.4	36.6	24.1	799.6	5.74	37.4	13	210	62	3.44	8.87
914x419x343 #	343.3	911.8	418.5	19.4	32.0	24.1	799.6	6.54	41.2	12	210	58	3.42	9.95
914x305x289 #	289.1	926.6	307.7	19.5	32.0	19.1	824.4	4.81	42.3	12	156	52	3.01	10.4
914x305x253 #	253.4	918.4	305.5	17.3	27.9	19.1	824.4	5.47	47.7	11	156	48	2.99	11.8
914x305x224 #	224.2	910.4	304.1	15.9	23.9	19.1	824.4	6.36	51.8	10	156	44	2.97	13.3
914x305x201 #	200.9	903.0	303.3	15.1	20.2	19.1	824.4	7.51	54.6	10	156	40	2.96	14.7
838x292x226 #	226.5	850.9	293.8	16.1	26.8	17.8	761.7	5.48	47.3	10	150	46	2.81	12.4
838x292x194 #	193.8	840.7	292.4	14.7	21.7	17.8	761.7	6.74	51.8	9	150	40	2.79	14.4
838x292x176 #	175.9	834.9	291.7	14.0	18.8	17.8	761.7	7.76	54.4	9	150	38	2.78	15.8
762x267x197	196.8	769.8	268.0	15.6	25.4	16.5	686.0	5.28	44.0	10	138	42	2.55	13.0
762x267x173	173.0	762.2	266.7	14.3	21.6	16.5	686.0	6.17	48.0	9	138	40	2.53	14.6
762x267x147	146.9	754.0	265.2	12.8	17.5	16.5	686.0	7.58	53.6	8	138	34	2.51	17.1
762x267x134	133.9	750.0	264.4	12.0	15.5	16.5	686.0	8.53	57.2	8	138	32	2.51	18.7
686x254x170	170.2	692.9	255.8	14.5	23.7	15.2	615.1	5.40	42.4	9	132	40	2.35	13.8
686x254x152	152.4	687.5	254.5	13.2	21.0	15.2	615.1	6.06	46.6	9	132	38	2.34	15.4
686x254x140	140.1	683.5	253.7	12.4	19.0	15.2	615.1	6.68	49.6	8	132	36	2.33	16.6
686x254x125	125.2	677.9	253.0	11.7	16.2	15.2	615.1	7.81	52.6	8	132	32	2.32	18.5
610x305x238	238.1	635.8	311.4	18.4	31.4	16.5	540.0	4.96	29.3	11	158	48	2.45	10.3
610x305x179	179.0	620.2	307.1	14.1	23.6	16.5	540.0	6.51	38.3	9	158	42	2.41	13.5
610x305x149	149.2	612.4	304.8	11.8	19.7	16.5	540.0	7.74	45.8	8	158	38	2.39	16.0
610x229x140	139.9	617.2	230.2	13.1	22.1	12.7	547.6	5.21	41.8	9	120	36	2.11	15.1
610x229x125	125.1	612.2	229.0	11.9	19.6	12.7	547.6	5.84	46.0	8	120	34	2.09	16.7
610x229x113	113.0	607.6	228.2	11.1	17.3	12.7	547.6	6.60	49.3	8	120	30	2.08	18.4
610x229x101	101.2	602.6	227.6	10.5	14.8	12.7	547.6	7.69	52.2	7	120	28	2.07	20.5
533x210x122	122.0	544.5	211.9	12.7	21.3	12.7	476.5	4.97	37.5	8	110	34	1.89	15.5
533x210x109	109.0	539.5	210.8	11.6	18.8	12.7	476.5	5.61	41.1	8	110	32	1.88	17.2
533x210x101	101.0	536.7	210.0	10.8	17.4	12.7	476.5	6.03	44.1	7	110	32	1.87	18.5
533x210x92	92.1	533.1	209.3	10.1	15.6	12.7	476.5	6.71	47.2	7	110	30	1.86	20.2
533x210x82	82.2	528.3	208.8	9.6	13.2	12.7	476.5	7.91	49.6	7	110	26	1.85	22.5

+ Section is not given in BS 4-1: 1993.

Check availability.

FOR EXPLANATION OF TABLES SEE NOTE 2

TABLE 2 / JADUAL 2**Table 2****Bolt data 1247**

BS 5950-1: 2000
BS 4395: 1969
BS 4604: 1970

BOLT CAPACITIES**PRELOADED HSFG BOLTS: NON-SLIP IN SERVICE****GENERAL GRADE HSFG BOLTS IN S275**

Diameter of Bolt mm	Min. Shank Tension P_o kN	Tension		Shear Capacity		Slip Resistance for $\mu = 0.5$		Bearing Capacity, P_{bg} in kN										
		$1.1P_o$ kN	$A_p \rho_t$ kN	Single Shear kN	Double Shear kN	Single Shear kN	Double Shear kN	End distance equal to 3 x bolt diameter. Thickness in mm of ply passed through.										
								5	6	7	8	9	10	12	15	20	25	30
12	49.4	54.3	49.7	33.7	67.4	27.2	54.3	41.4	49.7	58.0	66.2	74.5	82.8	99.4	124	166	207	248
16	92.1	101	92.6	62.8	126	50.7	101	55.2	66.2	77.3	88.3	99.4	110	132	166	221	276	331
20	144	158	145	98.0	196	79.2	158	69.0	82.8	96.6	110	124	138	166	207	276	345	414
22	177	195	179	121	242	97.4	195	75.9	91.1	106	121	137	152	182	228	304	380	465
24	207	228	208	141	282	114	228	82.8	99.4	116	132	149	166	199	248	331	414	497
27	234	257	236	161	321	129	257	93.2	112	130	149	168	186	224	279	373	466	559
30	286	315	289	196	393	157	315	104	124	145	166	186	207	248	311	414	518	621

Values in bold are less than the single shear capacity of the bolt.

Values in *italic* are greater than the double shear capacity of the bolt.

Shading indicates that the ply thickness is not suitable for an outer ply.

HIGHER GRADE HSFG BOLTS IN S275

Diameter of Bolt mm	Min. Shank Tension P_o kN	Tension		Shear Capacity		Slip Resistance for $\mu = 0.5$		Bearing Capacity, P_{bg} in kN										
		$1.1P_o$ kN	$A_p \rho_t$ kN	Single Shear kN	Double Shear kN	Single Shear kN	Double Shear kN	End distance equal to 3 x bolt diameter. Thickness in mm of ply passed through.										
								5	6	7	8	9	10	12	15	20	25	30
16	104	114	110	62.8	126	57.1	114	55.2	66.2	77.3	88.3	99.4	110	132	166	221	276	331
20	162	178	172	98.0	196	89.0	178	69.0	82.8	96.6	110	124	138	166	207	276	345	414
22	203	220	212	121	242	110	220	75.9	91.1	106	121	137	152	182	228	304	380	465
24	233	257	247	141	282	128	257	82.8	99.4	116	132	149	166	199	248	331	414	497
27	303	333	321	161	321	167	333	93.2	112	130	149	168	186	224	279	373	466	559
30	370	407	393	196	393	204	407	104	124	145	166	186	207	248	311	414	518	621

Values in bold are less than the single shear capacity of the bolt.

Values in *italic* are greater than the double shear capacity of the bolt.

Shading indicates that the ply thickness is not suitable for an outer ply.

TABLE 3 / JADUAL 31236 *Bolt data***Table 3****Bolt data**

Hole sizes -- for ordinary bolts and friction grip connections

Nominal diameter (mm)	Clearance hole diameter ^a (mm)	Oversize hole diameter ^a (mm)	Short slotted holes ^a (mm)		Long slotted holes ^a (mm)	
			Narrow dimension	Slot dimension	Narrow dimension	Maximum dimension
M12 ^a	14	17	14	18	14	30
M16	18	21	18	22	18	40
M20	22	25	22	26	22	50
M22	24	27	24	28	24	55
M24	26	30	26	32	26	60
M27	30	35	30	37	30	67
M30	33	38	33	40	33	75

^aHardened washers to be used^aIn cases where there are more than three piles in joint the holes in the inner plies should be one millimetre larger than those in the outer plies**Bolt strengths**

	Bolt grade		Steel grade		
	4.6	8.8	S275	S355	S460
Shear strength, p_s (N/mm ²)	160	375			
Bearing strength, p_{bb} (N/mm ²)	460	1000 ^a	460	550	670
Tension strength, p_t (N/mm ²)	240	560			

^aThe bearing value of the connected part is critical

For S355; the nominal yield strength, $f_{nom} = 355 \text{ N/mm}^2$ (355 MPa)

TABLE 4 / JADUAL 4

EQUAL ANGLES

Table 4

DIMENSIONS AND PROPERTIES

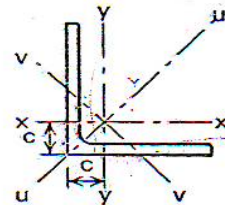
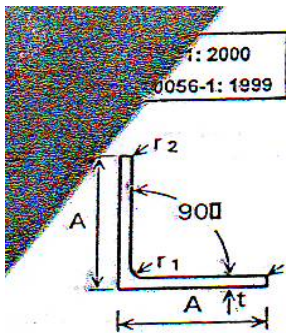

Section Designation		Mass per Metre	Radius		Area of Section	Dimension	Second Moment of Area			Radius of Gyration			Elastic Modulus	Torsional Constant	Equivalent Slenderness Coefficient
Size	Thickness		Root	Toe			Axis	Axis	Axis	Axis	Axis	Axis			
A x A mm	t mm	kg/m	r ₁ mm	r ₂ mm	cm ²	c cm	x-x, y-y cm ⁴	u-u cm ⁴	v-v cm ⁴	x-x, y-y cm	u-u cm	v-v cm	cm ³	J cm ⁴	φ _a
200x200	24 #	71.1	18.0	9.00	90.6	5.84	3330	5280	1380	6.06	7.64	3.90	235	182	2.50
	20	59.9	18.0	9.00	76.3	5.68	2850	4530	1170	6.11	7.70	3.92	199	107	3.05
	18	54.3	18.0	9.00	69.1	5.60	2600	4150	1050	6.13	7.75	3.90	181	78.9	3.43
	16	48.5	18.0	9.00	61.8	5.52	2340	3720	960	6.16	7.76	3.94	162	56.1	3.85
150x150	18 #	40.1	16.0	8.00	51.2	4.38	1060	1680	440	4.55	5.73	2.93	99.8	58.6	2.48
	15	33.8	16.0	8.00	43.0	4.25	898	1430	370	4.57	5.76	2.93	83.5	34.6	3.01
	12	27.3	16.0	8.00	34.8	4.12	737	1170	303	4.60	5.80	2.95	67.7	18.2	3.77
	10	23.0	16.0	8.00	29.3	4.03	624	990	258	4.62	5.82	2.97	56.9	10.80	4.51
120x120	15 #	26.6	13.0	6.50	34.0	3.52	448	710	186	3.63	4.57	2.34	52.8	27.0	2.37
	12	21.6	13.0	6.50	27.5	3.40	368	584	152	3.65	4.60	2.35	42.7	14.2	2.99
	10	18.2	13.0	6.50	23.2	3.31	313	497	129	3.67	4.63	2.36	36.0	8.41	3.61
	8 #	14.7	13.0	6.50	18.8	3.24	259	411	107	3.71	4.67	2.38	29.5	4.44	4.56
100x100	15 #	21.9	12.0	6.00	28.0	3.02	250	395	105	2.99	3.76	1.94	35.8	22.3	1.92
	12	17.8	12.0	6.00	22.7	2.90	207	328	85.7	3.02	3.80	1.94	29.1	11.8	2.44
	10	15.0	12.0	6.00	19.2	2.82	177	280	73.0	3.04	3.83	1.95	24.6	6.97	2.94
	8	12.2	12.0	6.00	15.5	2.74	145	230	59.9	3.06	3.85	1.96	19.9	3.68	3.70
90x90	12 #	15.9	11.0	5.50	20.3	2.66	149	235	62.0	2.71	3.40	1.75	23.5	10.46	2.17
	10	13.4	11.0	5.50	17.1	2.58	127	201	52.6	2.72	3.42	1.75	19.8	6.20	2.64
	8	10.9	11.0	5.50	13.9	2.50	104	166	43.1	2.74	3.45	1.76	16.1	3.28	3.33
	7 #	9.61	11.0	5.50	12.2	2.45	92.6	147	38.3	2.75	3.46	1.77	14.1	2.24	3.80
80x80	10 □	11.9	10.0	5.00	15.1	2.34	87.5	139	36.4	2.41	3.03	1.55	15.4	5.45	2.33
	8 □	9.63	10.0	5.00	12.3	2.26	72.2	115	29.9	2.43	3.06	1.56	12.6	2.88	2.94
75x75	8 □	8.99	9.00	4.50	11.4	2.14	59.1	93.8	24.5	2.27	2.86	1.46	11.0	2.65	2.76
	6 □	6.85	9.00	4.50	8.73	2.05	45.8	72.7	18.9	2.29	2.89	1.47	8.41	1.17	3.70
70x70	7 □	7.38	9.00	4.50	9.40	1.97	42.3	67.1	17.5	2.12	2.67	1.36	8.41	1.69	2.92
	6 □	6.38	9.00	4.50	8.13	1.93	36.9	58.5	15.3	2.13	2.68	1.37	7.27	1.093	3.41
65x65	7 □	6.83	9.00	4.50	8.73	2.05	33.4	53.0	13.8	1.96	2.47	1.26	7.18	1.58	2.67
60x60	8 □	7.09	8.00	4.00	9.03	1.77	29.2	46.1	12.2	1.80	2.26	1.16	6.89	2.09	2.14
	6 □	5.42	8.00	4.00	6.91	1.69	22.8	36.1	9.44	1.82	2.29	1.17	5.29	0.922	2.90
	5 □	4.57	8.00	4.00	5.82	1.64	19.4	30.7	8.03	1.82	2.30	1.17	4.45	0.550	3.48
50x50	6 □	4.47	7.00	3.50	5.69	1.45	12.8	20.3	5.34	1.50	1.89	0.968	3.61	0.755	2.38
	5 □	3.77	7.00	3.50	4.80	1.40	11.0	17.4	4.55	1.51	1.90	0.973	3.05	0.450	2.88
	4 □	3.06	7.00	3.50	3.89	1.36	8.97	14.2	3.73	1.52	1.91	0.979	2.46	0.240	3.57
45x45	4.5 □	3.06	7.00	3.50	3.90	1.25	7.14	11.4	2.94	1.35	1.71	0.870	2.20	0.304	2.84
40x40	5 □	2.97	6.00	3.00	3.79	1.16	5.43	8.60	2.26	1.20	1.51	0.773	1.91	0.352	2.26
	4 □	2.42	6.00	3.00	3.08	1.12	4.47	7.09	1.86	1.21	1.52	0.777	1.55	0.188	2.83
35x35	4 □	2.09	5.00	2.50	2.67	1.00	2.95	4.68	1.23	1.05	1.32	0.678	1.18	0.158	2.50
30x30	4 □	1.78	5.00	2.50	2.27	0.878	1.80	2.85	0.754	0.892	1.12	0.577	0.850	0.137	2.07
	3 □	1.36	5.00	2.50	1.74	0.835	1.40	2.22	0.585	0.899	1.13	0.581	0.649	0.0613	2.75
25x25	4 □	1.45	3.50	1.75	1.85	0.762	1.02	1.61	0.430	0.741	0.931	0.482	0.586	0.1070	1.75
	3 □	1.12	3.50	1.75	1.42	0.723	0.803	1.27	0.334	0.751	0.945	0.484	0.452	0.0472	2.38
20x20	3 □	0.882	3.50	1.75	1.12	0.598	0.392	0.618	0.165	0.590	0.742	0.383	0.279	0.0382	1.81

? Not available from some leading producers. Check availability.

Check availability.

c is the distance from the back of the leg to the centre of gravity.

FOR EXPLANATION OF TABLES SEE NOTES 2 AND 3