UNIVERSITI SAINS MALAYSIA

Second Semester Examination
2009/2010 Academic Session

April/May 2010

EAG 245/3 – Soil Mechanics [*Mekanik Tanah*]

Duration : 3 hours
[*Masa : 3 jam*]

Please check that this examination paper consists of **THIRTEEN (13)** pages of printed material before you begin the examination.

[*Sila pastikan bahawa kertas peperiksaan ini mengandungi **TIGA BELAS (13)** muka surat yang bercetak sebelum anda memulakan peperiksaan ini.*]

Instructions : This paper contains **SIX (6)** questions. Answer **FIVE (5)** questions only. Marks will be given to the **FIRST FIVE (5)** question put in order on the answer script and **NOT** the **BEST FIVE (5)**.

[***Arahan** : Kertas ini mempunyai **ENAM (6)** soalan. Jawab **LIMA (5)** soalan sahaja. Markah akan diberikan kepada **LIMA (5)** soalan yang pertama dan bukannya **LIMA (5)** jawapan yang bagus. Susun soalan mengikut turutan didalam skrip jawapan.*]

You may answer the question either in Bahasa Malaysia or English.

[*Anda dibenarkan menjawab soalan sama ada dalam Bahasa Malaysia atau Bahasa Inggeris*].

All questions **MUST BE** answered on a new page.

[*Semua soalan **MESTILAH** dijawab pada muka surat baru*].

In the event of any discrepancies, the English version shall be used.

[*Sekiranya terdapat percanggahan pada soalan peperiksaan, versi Bahasa Inggeris hendaklah diguna pakai*].

1. (a) What are the meanings of effective stress, total stress and pore water pressure. Give the equation that relates the three parameters.

[6 marks]

- (b) Based on the soil investigation, the profile as shown in Figure 1 is obtained. Draw the following distribution :-

- i. total vertical pressure with depth
- ii. effective vertical pressure with depth

[14 marks]

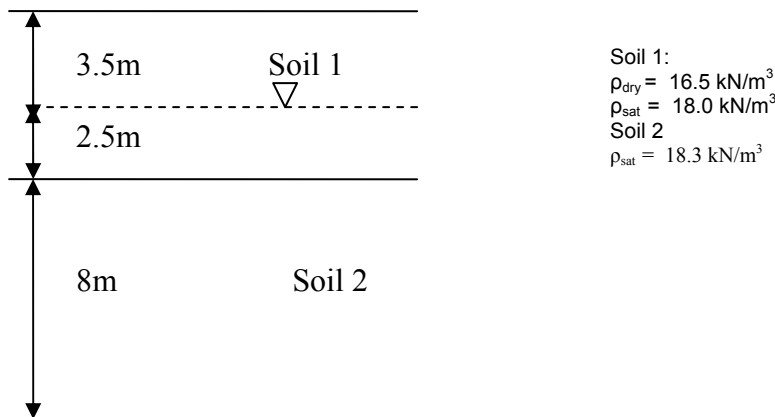

Figure 1

2. (a) What are the rules to draw the flownet? Give **FIVE (5)** conditions.

[5 marks]

- (b) Draw the flownet for seepage under the structure detailed in Figure 2 and determine the quantity of seepage. The coefficient of permeability of soil is $5.0 \times 10^{-5} \text{ m/s}$. How much is the uplift force on the base of the structure.

[15 marks]

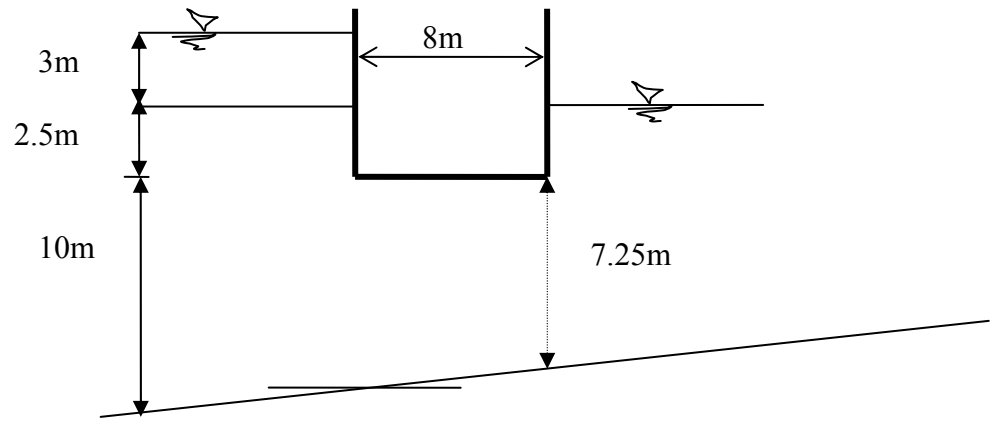

Figure 2

3. Figure 3 illustrates **FOUR (4)** proposed sites (A,B,C,D) for housing development project.

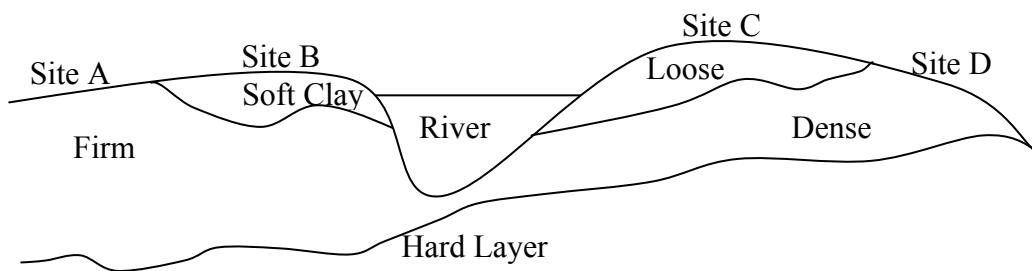

Figure 3

- (a) Identify and give **ONE (1)** main reason for each site whether soil improvement using compaction is required or not.
- [6 marks]
- (b) Table 1 shows result of standard compaction test for sample taken from one of the proposed site.

Table 1

Bulk Unit Weight (kN/m ³)	20.0	20.7	21.7	21.4	21.1
Water Content (%)	8.0	9.5	11.5	12.5	13.5

- i. Determine dry unit weight and water content at 95% standard compaction based on the result of a standard compaction test given in Table 1.

[8 marks]

- ii. Describe briefly effect of water content during compaction between 9.5% water content to 12.5% water content.

[6 marks]

4. (a) A deposit of fine dry sand ($G_s=2.67$) with an in-place unit weight of 18.28 kN/m^3 has void ratios of 0.361 and 0.940 at its densest and loosest condition respectively. Calculate the relative density of the sand deposit.

[5 marks]

- (b) In an experiment for the determination of shrinkage limit (SL) of a soil, the following results were obtained :-

$$\text{Volume of wet soil} = 9.75 \text{ cm}^3$$

$$\text{Volume of oven – dried sample} = 5.40 \text{ cm}^3$$

$$\text{Mass of wet soil} = 16.50 \text{ g}$$

$$\text{Mass of dry sample after shrinkage} = 10.90 \text{ g}$$

Calculate,

- i. Shrinkage limit, SL, and
ii. Specific Gravity, G_s of the soil.

[5 marks]

(c) During the site investigation phase of a highway project, an undisturbed soil sample was collected from a borehole at 5 m depth below the ground. From the laboratory tests, it was found that the void ratio of the natural deposit was 0.78, with natural moisture content of 12% and a G_s value of 2.68. With the help of these information, calculate the following parameters :-

- i. Wet Unit weight
- ii. Dry Unit weight
- iii. Degree of saturation
- iv. Porosity

[10 marks]

5. (a) What are the parameters required to classify soil using AASHTO?

[3 marks]

(b) Name the major groups of soils in AASHTO classification system.

[2 marks]

(c) A sample of inorganic soil was tested in the laboratory for mechanical analysis and following grain size distribution, as shown in Table 2, was obtained. The Atterberg's limit were: $LL = 42$, $PL = 16$.

Table 2

US sieve size	% passing
#4	100.0
#10	93.2
#40	81.0
#200	60.2

With the help of Plasticity chart, classify the soil sample by USCS. Refer to Figure 4.

[5 marks]

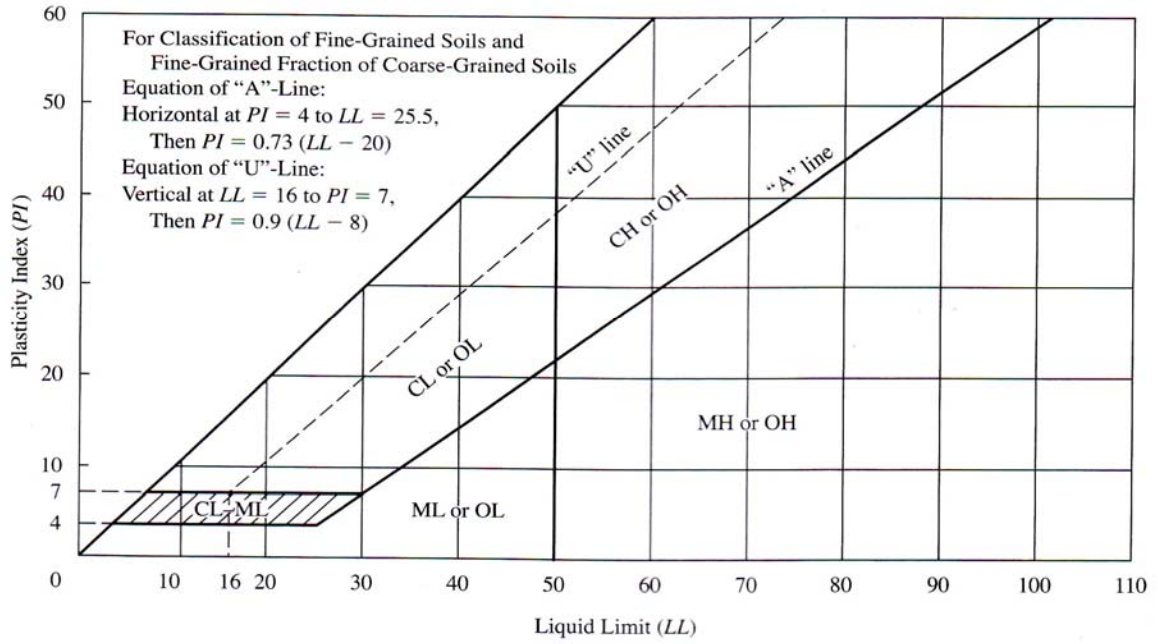

Figure 4

- (d) A field soil sample for an embankment project was tested in the laboratory with the following results. Mechanical analysis for Table 3.

Table 3

US Sieve size	% passing
1 in	100
¾ in	85
½ in	70
3/8 in	60
#4	48
#10	30
#40	16
#100	10
#200	2

Determine C_u and C_c .

[10 marks]

6. (a) Starting from a soil phase diagram and the other basic theory of the consolidation, define the relationship between the consolidation settlement with the other basic parameters.

[5 marks]

Table 4

Pressure kN/m²	Void ratio at the end of test
200	0.96
400	0.80

- b) The following results in Table 4 were obtained from a set of consolidation test on a specimen of a clay sample taken from a 4m thick clay layer on one construction site which are overlaid and underlaid by a thick layer of coarse sand.

The initial thickness of the tested sample was 19.0 mm with a moisture content of 20 %. The sample take 4.5 minutes to achieve 35 % of consolidation.

- i. Estimate the total consolidation settlement of the clay layer.
[5 marks]
- ii. Estimate the time to achieve 30 %, 50 % and 90 % consolidation.
[5 marks]
- iii. Suggest a method to accelerate the consolidation process of the above clay layer. Used sketches to support your answers.
[5 marks]

1. (a) Apakah yang di maksudkan dengan tegasan berkesan, tegasan jumlah dan tekanan air liang. Berikan persamaan yang mengaitkan ketiga-tiga parameter tersebut.

[6 markah]

- (b) Berdasarkan penyiasatan tapak yang telah di perolehi seperti dalam Rajah 1. Lakarkan taburan berikut;-

- i. tekanan pugak dengan kedalaman
- ii. tekanan berkesan pugak dengan kedalaman

[14 markah]

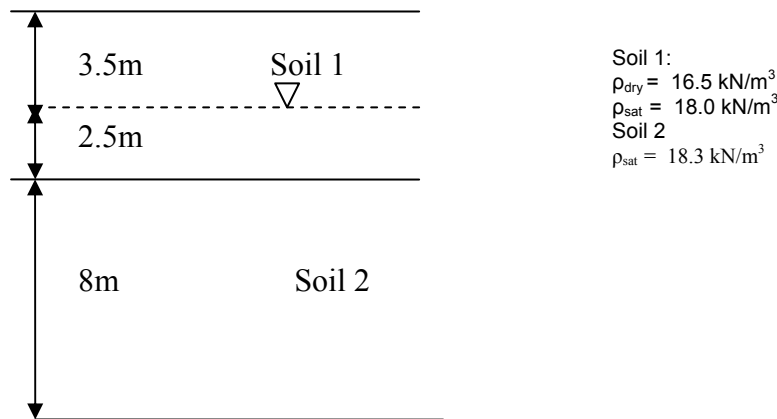

Rajah 1

2. (a) Apakah garis panduan keperluan melakar jaringan aliran? Beri **LIMA (5)** keadaan.

[5 markah]

- (b) Lakar jaringan aliran resipan di bawah struktur seperti butiran dalam Rajah 2 dan tentukan kuantiti resipan. Pekali kebolehtelapan untuk tanah adalah $5.0 \times 10^{-5} \text{ m/s}$. Berapakah Daya Terangkat pada dasar struktur tersebut.

[15 markah]

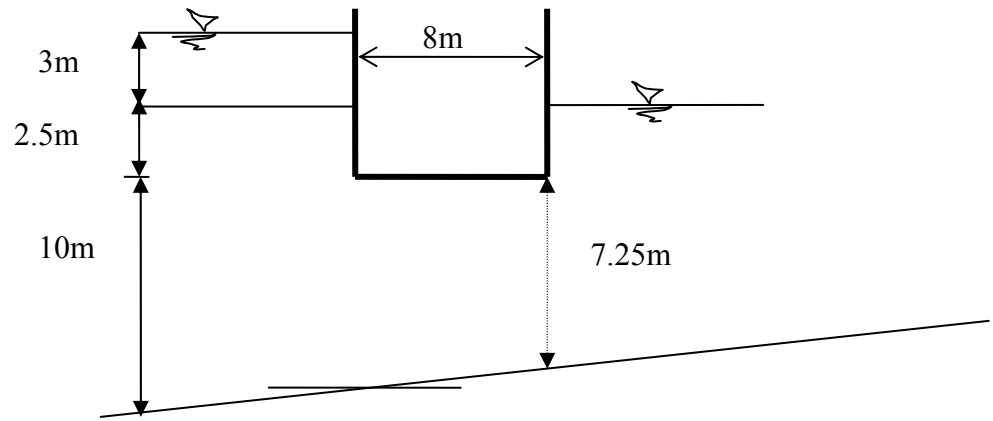

Rajah 2

3. *Rajah 3 menunjukkan EMPAT (4) tapak cadangan (A,B,C,D).*

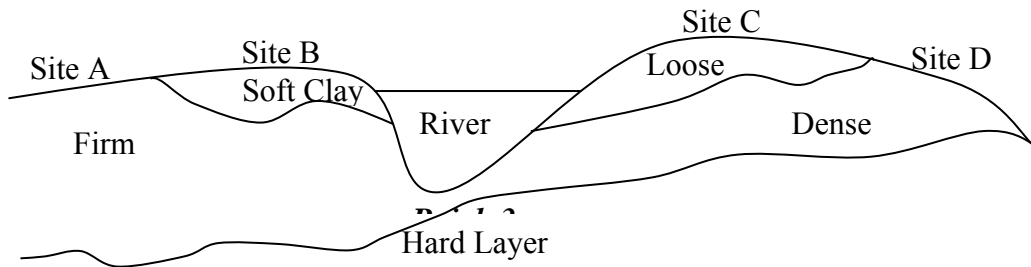

(a) *Kenalpasti dan berikan SATU (1) sebab utama bagi setiap tapak adakah pembaikan tanah menggunakan pepadatan diperlukan atau tidak.*

[6 markah]

(b) *Jadual 1 menunjukkan keputusan ujian pepadatan piawai bagi sampel yang diambil daripada salah satu tapak cadangan.*

Jadual 1

Bulk Unit Weight (kN/m ³)	20.0	20.7	21.7	21.4	21.1
Water Content (%)	8.0	9.5	11.5	12.5	13.5

- i. Tentukan berat unit kering dan kandungan air pada 95% pepadatan piawai berdasarkan keputusan ujian pepadatan piawai seperti di Jadual 1.

[8 markah]

- ii. Terangkan secara ringkas kesan kandungan air ketika pepadatan antara 9.5% kandungan air hingga 12.5% kandungan air.

[6 markah]

4. (a) Tanah pasir kering halus ($G_s=2.67$) mempunyai berat unit di tapak 18.28 kN/m³ dengan nisbah lompang 0.361 dan 0.940 pada keadaan padat dan longgar mengikut turutan. Kira ketumpatan nisbi ke atas pasir endapan.

[5 markah]

- (b) Suatu eksperimen penentuan had kecutan tanah (SL) diperolehi, berikut adalah keputusannya :-

$$\text{Ispadu tanah basah} = 9.75 \text{ cm}^3$$

$$\text{Ispadu sampel kering-ketuhar} = 5.40 \text{ cm}^3$$

$$\text{Jisim tanah basah} = 16.50 \text{ g}$$

$$\text{Jisim sampel kering kecutan} = 10.90 \text{ g}$$

Kira,

- i. Had kecutan SL, dan
ii. Graviti spesifik, G_s tanah.

[5 markah]

(c) *Ketika penyiasatan tapak bagi projek lebuh raya, sampel tanah tidak terganggu telah di ambil daripada satu lubang jara pada kedalaman 5 m di bawah permukaan tanah. Daripada ujian makmal, di dapati nisbah lompang endapan semulajadi adalah 0.78 dengan kandungan lembapan semulajadi 12% dan nilai G_s 2.68. berpandukan maklumat ini, kira parameter tersebut.*

- i. Berat unit basah*
- ii. Berat unit kering*
- iii. Darjah ketepuan*
- iv. Keliangan*

[10 markah]

5. (a) *Apakah parameter yang diperlukan untuk klasifikasi tanah menggunakan AASHTO?*

[3 markah]

(b) *Namakan kumpulan utama dalam sistem pengelasan tanah AASHTO.*

[2 markah]

(c) *Satu sampel tanah tak organik telah diuji di makmal bagi analisis mekanikal dan taburan saiz butiran seperti Jadual 2, dimana $LL = 42$, $PL = 16$.*

Jadual 2

US sieve size	% passing
#4	100.0
#10	93.2
#40	81.0
#200	60.2

Dengan berbantuan carta plastisiti, kelaskan sampel tanah menggunakan USCS. Rujuk Rajah 4.

[5 markah]

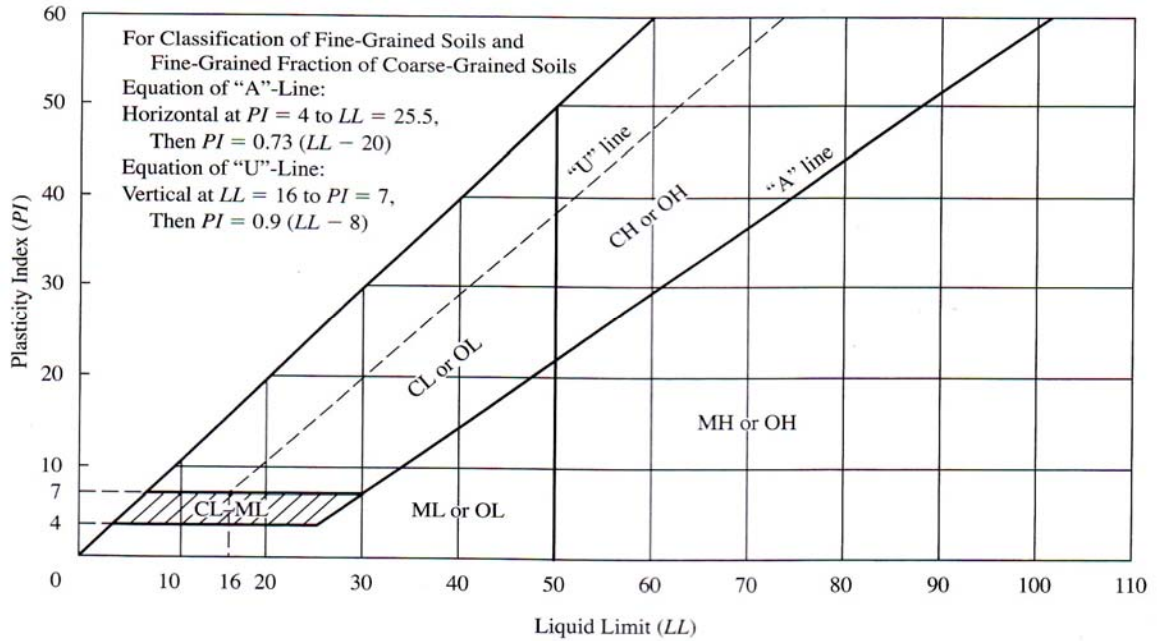

Rajah 4

- (d) *Sampel tanah tak plastik di tapak bagi projek tambakkan telah diuji di makmal dengan keputusan diberikan di Jadual 3.*

Jadual 3

US Sieve size	% passing
1 in	100
¾ in	85
½ in	70
3/8 in	60
#4	48
#10	30
#40	16
#100	10
#200	2

Tentukan C_u dan C_c .

[10 markah]

6. (a) *Bermula dari gambarajah fasa tanah dan teori asas proses pengukuhan tanah, berikan perhubungan antara pegenapan pengukuhan dengan parameter asas pengukuhan yang lain.*

[5 markah]

Jadual 4

<i>Tegasan kN/m²</i>	<i>Nisbah lompang di akhir ujian</i>
200	0.96
400	0.80

- b) *Data di Jadual 4 diperolehi dari satu set ujian pengukuhan di makmal ke atas satu spesimen tanah lempung yang diambil dari satu lapisan tanah lempung di suatu tapak bina setebal 4m. Tanah lempung tersebut dilapisi oleh lapisan pasir kasar yang tebal di bahagian atas dan bawah.*

Tebal asal spesimen adalah 19.0 mm dan kandungan lembapan sebesar 20 %. Sampel ini mengambil masa 4.5 minit untuk mencapai 35 % pengukuhan.

- i. Anggarkan jumlah pegenapan pengukuhan yang akan berlaku keatas lapisan tanah lempung di tapak bina diatas perubahan tegasan di atas.*
[5 markah]
- ii. Anggarkan masa untuk mencapai 30 %, 50 % and 90 % pengukuhan.*
[5 markah]
- iii. Cadangkan satu kaedah untuk mempercepatkan proses pengukuhan di atas. Gunakan lakaran untuk menyokong jawapan anda.*
[5 markah]

oooOOOooo