UNIVERSITI SAINS MALAYSIA

Second Semester Examination
2009/2010 Academic Session

April/May 2010

EKC 367 – Plant Safety
[Keselamatan Loji]

Duration : 3 hours
[Masa : 3 jam]

Please ensure that this examination paper contains EIGHT printed pages and SEVEN printed page of Appendix before you begin the examination.

[Sila pastikan bahawa kertas peperiksaan ini mengandungi LAPAN muka surat yang bercetak dan TUJUH muka surat Lampiran sebelum anda memulakan peperiksaan ini.]

Instruction: Answer any **FIVE (5)** questions. All questions carry the same marks.

Arahan: Jawab mana-mana **LIMA (5)** soalan. Semua soalan membawa jumlah markah yang sama.]

In the event of any discrepancies, the English version shall be used.

[Sekiranya terdapat sebarang percanggahan pada soalan peperiksaan, versi Bahasa Inggeris hendaklah digunapakai].

Answer any FIVE questions.

Jawab mana-mana LIMA soalan.

1. [a] [i] Write briefly on the inherent safety in the chemical plant.
Tuliskan secara ringkas mengenai keselamatan terwujud di loji kimia.
[6 marks/markah]
- [ii] Describe the inherent safety techniques used in the chemical plant.
Huraikan teknik-teknik kawalan keselamatan terwujud yang digunakan di dalam loji kimia.
[4 marks/markah]
- [b] If all travelers used commercial airlines twice as much, what will happen to
Jika semua pengembara menggunakan penerbangan komersial sebanyak dua kali ganda, apa akan terjadi kepada
- [i] OSHA incidence rate
Kadar insiden OSHA [1 mark/markah]
- [ii] FAR [1 mark/markah]
- [iii] Fatality rate
Kadar kematian [1 mark/markah]
- [iv] Total number of fatalities
Jumlah keseluruhan kematian [1 mark/markah]
- [c] A car leaves Nibong Tebal and travels 400 km to Kota Bharu at an average speed of 80 km/hour. An alternative travel plan is to fly with Firefly for 45 minutes. What is the FAR for the two methods of transportation? Which travel method is safer, based on the FAR?
Sebuah kereta meninggalkan Nibong Tebal dan bergerak sejauh 400 km ke Kota Bharu pada halaju purata 80 km/jam. Plan alternatif perjalanan ialah terbang dengan Firefly selama 45 minit. Berapa FAR untuk kedua-dua kaedah perjalanan? Kaedah perjalanan mana lebih selamat, berdasarkan FAR?
[6 marks/markah]

2. [a] Briefly explain the followings:
Terangkan secara ringkas:

[i] ED₉₀ [2 marks/markah]

[ii] TD₁₀ [2 marks/markah]

[iii] LD₅₀ [2 marks/markah]

[b] Using the following data (Table Q.2.[b]), determine the probit constants and the LC₅₀.

Menggunakan data berikut (Jadual S.2.[b]), tentukan pemalar-pemalar probit dan LC₅₀.

Table Q.2.[b].
Jadual S.2.[b].

Dose of Rotenone (mg/l)	Number of insects	Number affected (deaths)
10.2	50	44
7.7	49	42
5.1	46	24
3.8	48	16
2.6	50	6

[9 marks/markah]

[c] Propylene is stored at 25°C in a cylindrical tank at its saturation pressure. A hole of 1-cm diameter develops in the tank due to metal fatigue. Estimate the mass flow rate through hole.

Propilena disimpan pada suhu 25°C di dalam sebuah tangki silinder pada tekanan tepu. Satu lubang berdiameter 1 sm terbentuk pada tangki akibat kelesuan logam. Anggarkan kadar aliran jisim menerusi lubang.

Given data for propylene at 25°C: $\Delta H_v = 3.34 \times 10^5 \text{ J/kg}$, $v_{fg} = 0.042 \text{ m}^3/\text{kg}$, $P^{\text{sat}} = 1.15 \times 10^6 \text{ Pa}$, $C_p = 2.18 \times 10^3 \text{ J/Kg.K}$ and $\rho = 514 \text{ kg/m}^3$

Diberi data propilena pada 25°C: $\Delta H_v = 3.34 \times 10^5 \text{ J/kg}$, $v_{fg} = 0.042 \text{ m}^3/\text{kg}$, $P^{\text{sat}} = 1.15 \times 10^6 \text{ Pa}$, $C_p = 2.18 \times 10^3 \text{ J/Kg.K}$ dan $\rho = 514 \text{ kg/m}^3$

[5 marks/markah]

3. [a] Will the content of the vessel flammable if a process vessel contains pentane (C_5H_{12}) at a concentration of 2 vol % in air? C_5H_{12} has the lower and upper flammability limit of 1.5 and 7.8, respectively. Why?

Bolehkah kandungan dalam bekas terbakar jika ia mengandungi pentana (C_5H_{12}) pada kepekatan 2 isipadu % di udara? C_5H_{12} mengandungi had kemudahbakaran bawah dan atas masing-masing sebanyak 1.5 dan 7.8. Kenapa?

[3 marks/markah]

- [b] Do you agree with the statement that the type of molecule and the amount released are the only factors that determine the strength of a vapor cloud explosion? Why?

Adakah anda setuju dengan kenyataan bahawa jenis molekul dan amaun yang dibebaskan merupakan faktor tunggal yang menentukan kekuatan letupan wap awan. Kenapa?

[3 marks/markah]

- [c] One thousand kilograms of unknown hydrocarbon with an equivalent amount of 327.6 kg trinitrotoluene (TNT) escapes from a storage vessel, mixes with air, and explodes. The energy of explosion is 818.7 kJ/mol. Equivalent energy of TNT is 4686 kJ/kg. Ambient pressure is 101.3 kPa. Assume an explosion efficiency of 3%. Determine:

Seribu kilogram hidrokarbon yang tidak dikenal pasti mempunyai amaun setara dengan 327.6 kg trinitrotoluena (TNT) terbebas daripada sebuah bekas simpanan, bercampur dengan udara dan terbakar. Tenaga letupan ialah sebanyak 818.7 kJ/mol. Tenaga setara bagi TNT ialah sebanyak 4686 kJ/kg. Tekanan ambien ialah sebanyak 101.3 kPa. Anggapkan kecekapan letupan sebanyak 3%. Tentukan:

- [i] side-on peak overpressure at a distance of 100 m from the blast and estimate its damage

tekanan puncak lebih sisi pada jarak 100 m daripada letupan dan anggarkan kerosakannya

[8 marks/markah]

- [ii] the hydrocarbon that caused this explosion
hidrokarban yang menyebabkan letupan ini

[6 marks/markah]

4. [a] Describe one of the methods that commonly used in process industries to prevent fire and explosion.

Terangkan salah satu langkah yang lazim digunakan di industri proses untuk mencegah kebakaran dan letupan.

[5 marks/markah]

- [b] A coal-fired plant located in an urban area emits an estimated 1500 g/s of SO₂. Given the following parameters and conditions:

Sebuah loji arang batu yang terletak di kawasan luar bandar mengeluarkan SO₂ dengan anggaran 1500 g/s. Parameter dan keadaan adalah seperti berikut:

Stack Parameter:

Height = 120 m
Inside diameter = 1.5 m
Exit velocity = 10 m/s
Temperature = 315°C

Atmospheric conditions:

Pressure = 95 kPa
Temperature = 25°C

Parameter paip tumpu:

Tinggi = 120 m
Diameter dalam = 1.5 m
Halaju keluar = 10 m/s
Suhu = 315°C

Keadaan atmosfera:

Tekanan = 95 kPa
Suhu = 25°C

On an overcast night time, if the wind speed at the top of the stack is 4.2 m/s, determine the ground-level centerline concentration of SO₂ at 2.5 km downwind.

Pada malam yang mendung, jika halaju angin pada aras atas paip tumpu ialah 4.2 m/s, tentukan kepekatan SO₂ di aras bumi di sepanjang garis tengah pada jarak 2.5 km di hiliran terus angin.

[15 marks/markah]

5. [a] State the advantages and disadvantages of Fault Tree Analysis.
Nyatakan kebaikan dan keburukan Analisis Pokok Kegagalan.
[4 marks/markah]

[b] During Budget 2009, the Kedah state government proposed to invest in the development of ethylene production plant. A consultant company namely Kita Boleh Sdn Bhd has been appointed to develop the preliminary design of the plant as illustrated in Figure Q.5.[b]. Considering the safety of the plant, all control valves are designed to be operated both manually and automatically. All control valves need to be initiated before the process is started. As a chemical engineer employed by the consultant company, you have been asked to conduct the following tasks.

Semasa Bajet 2009, Kerajaan Negeri Kedah bercadang untuk melabur dalam pembangunan loji pengeluaran etilina. Sebuah syarikat perunding Kita Boleh Sdn Bhd telah dilantik untuk membangunkan rekaan awal loji tersebut seperti yang ditunjukkan dalam Gambarajah S.5.[b]. Dengan mengambil kira keselamatan loji tersebut, semua injap kawalan perlu dihidupkan secara manual atau automatik sebelum proses bermula. Sebagai seorang jurutera kimia yang dilantik oleh syarikat perunding tersebut, anda diarahkan untuk melakukan kerja-kerja berikut:

[i] Discuss the possible ways that can cause no ethane flow.
Bincangkan sebab-sebab yang membolehkan tiada aliran ethana.
[4 marks/markah]

[ii] Construct a Fault Tree Diagram with the top event of “No Ethane Flow”.
Bina suatu Gambarajah Pokok Kegagalan dengan peristiwa teratas “Tiada Aliran Etana”.
[12 marks/markah]

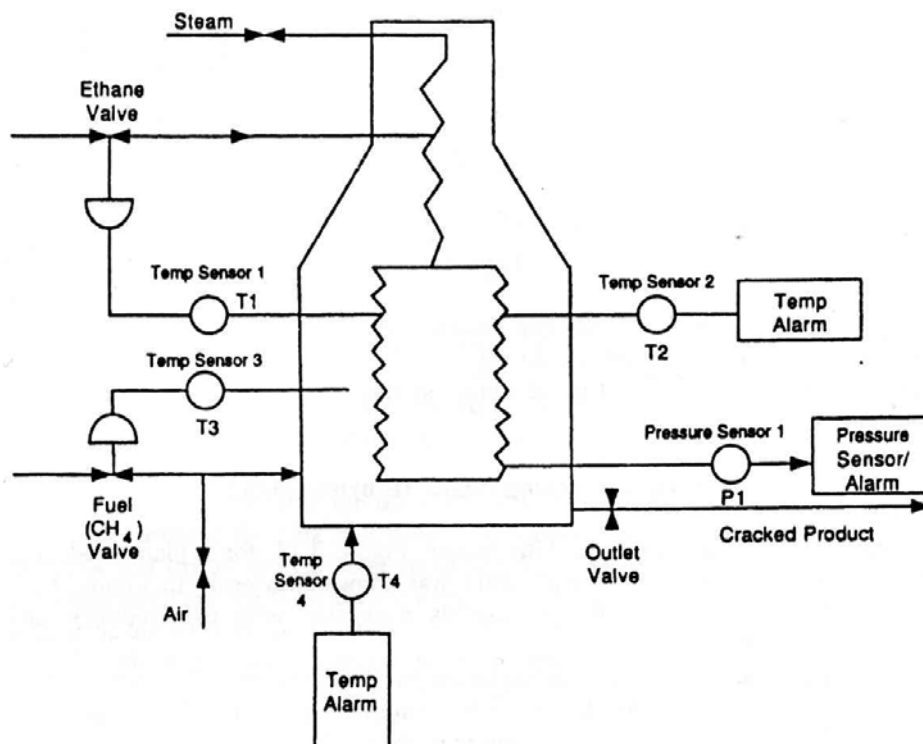

Figure Q.5.[b].
Gambarajah S.5.[b].

6. A simplified flow diagram of a high pressure/low density polyethylene plant is shown in Figure Q.6.[a]. Ethylene is compressed to about 1500 atmospheres and 195°C, mixed with a polymerization initiator and fed to a jacketed tubular reactor where 15-25% ethylene is converted per pass in order to reduce the dangers associated with the highly exothermic polymerization reaction. The product is sent to a high pressure separator to recover the ethylene and recycle it. The polymer is sent to a low pressure separator to remove residual ethylene which then compressed and recycled. The main hazards are due to runaway reactions which may arise due to the very exothermic nature of the polymerization reaction, and the inflammability/explosivity of ethylene. Cooling of the tubular reactor is therefore critical, as is the prevention of a large or prolonged ethylene leaks.

Gambarajah S.6.[a]. menunjukkan carta aliran loji polietilina bertekanan tinggi/berketumpatan rendah secara ringkas. Etilina dimampatkan kepada 1500 atmosfera dan 195°C, satu pemula pempolimeran dicampur dan hasil campuran disuapkan ke reaktor tuib berjaket di mana 15-25 % etilina ditukarkan per pas untuk mengurangkan bahaya-bahaya berkaitan dengan tindakbalas pempolimeran eksotermik. Produk di hantar ke pemisah bersuhu tinggi untuk memulih etilina dan diedar semula. Bahaya-bahaya utama adalah sisihan tindakbalas-tindakbalas yang mungkin disebabkan oleh sifat tindakbalas pempolimeran yang sangat eksotermik dan kemudahbakaran/kemudahletupan etilina. Maka penyejukan pada reaktor tuib adalah sangat kritikal dan juga pencegahan daripada kebocoran etilina yang berterusan.

- [a] Based on your knowledge in Process Control and Instrumentation, complete the process by adding the control instrumentations (control valves, indicators, etc) to safe guard the plant. (Use the Diagram provided in the Appendix Q.6.[a]. and attach to the answer script).

Berdasarkan pengetahuan anda dalam Kawalan Proses dan Instrumentasi, lengkapkan proses tersebut dengan penambahan instrumentasi-instrumentasi (injap kawalan, penunjuk dan lain-lain) untuk melindungi loji tersebut. (Guna gambarajah yang disediakan dalam Apendik S.6.[a] dan lampirkan pada kertas jawapan).

[10 marks/markah]

- [b] Conduct HAZOP analysis with the guidewords of
Lakukan Analisis HAZOP dengan katakunci-katakunci

[i] No cooling flow
Tiada aliran penyejukan

[3 marks/markah]

[ii] More cooling flow
Lebih aliran penyejukan

[3 marks/markah]

[iii] Less cooling flow.
Kurang aliran penyejukan

[4 marks/markah]

...8/-

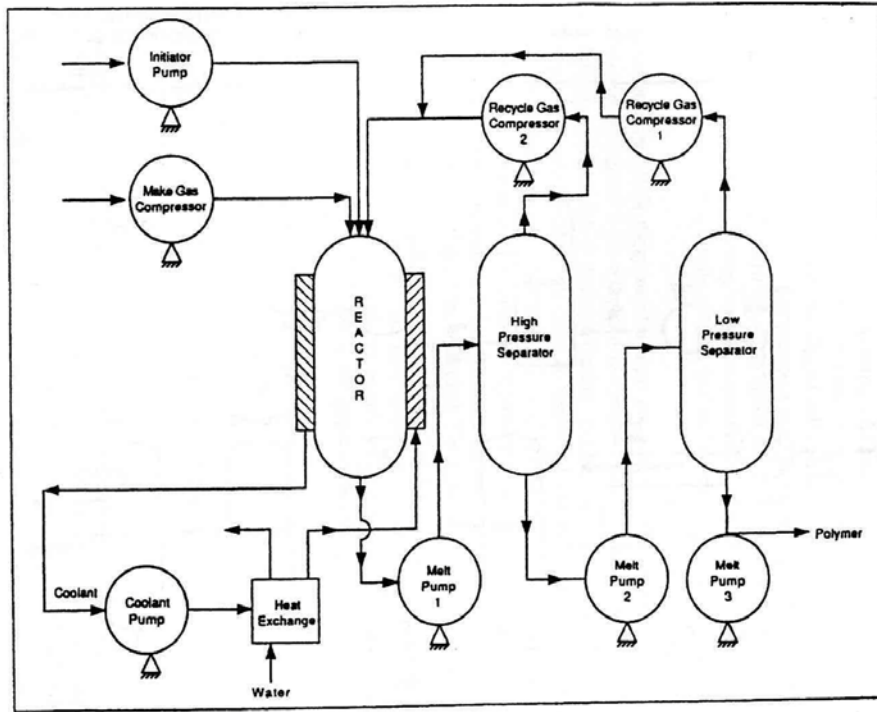

Figure Q.6.[a].
Gambarajah S.6.[a].

Appendix

Table 1-4 Fatality Statistics for Common Nonindustrial Activities^{1,2}

Activity	FAR (deaths/10 ⁸ hours)	Fatality rate (deaths per person per year)
Voluntary activity		
Staying at home	3	
Traveling by		
Car	57	17×10^{-5}
Bicycle	96	
Air	240	
Motorcycle	660	
Canoeing	1000	
Rock climbing	4000	4×10^{-5}
Smoking (20 cigarettes/day)		500×10^{-5}
Involuntary activity		
Struck by meteorite		6×10^{-11}
Struck by lightning (U.K.)		1×10^{-7}
Fire (U.K.)		150×10^{-7}
Run over by vehicle		600×10^{-7}

¹Frank P. Lees, *Loss Prevention in the Process Industries* (London: Butterworths, 1986), p. 178.

²Frank P. Lees, *Loss Prevention in the Process Industries*, 2d ed. (London: Butterworths, 1996), p. 9/96.

Table 2-4 Transformation from Percentages to Probits¹

%	0	1	2	3	4	5	6	7	8	9
0	—	2.67	2.95	3.12	3.25	3.36	3.45	3.52	3.59	3.66
10	3.72	3.77	3.82	3.87	3.92	3.96	4.01	4.05	4.08	4.12
20	4.16	4.19	4.23	4.26	4.29	4.33	4.36	4.39	4.42	4.45
30	4.48	4.50	4.53	4.56	4.59	4.61	4.64	4.67	4.69	4.72
40	4.75	4.77	4.80	4.82	4.85	4.87	4.90	4.92	4.95	4.97
50	5.00	5.03	5.05	5.08	5.10	5.13	5.15	5.18	5.20	5.23
60	5.25	5.28	5.31	5.33	5.36	5.39	5.41	5.44	5.47	5.50
70	5.52	5.55	5.58	5.61	5.64	5.67	5.71	5.74	5.77	5.81
80	5.84	5.88	5.92	5.95	5.99	6.04	6.08	6.13	6.18	6.23
90	6.28	6.34	6.41	6.48	6.55	6.64	6.75	6.88	7.05	7.33
%	0.0	0.1	0.2	0.3	0.4	0.5	0.6	0.7	0.8	0.9
99	7.33	7.37	7.41	7.46	7.51	7.58	7.65	7.75	7.88	8.09

¹D. J. Finney, *Probit Analysis*, (Cambridge: Cambridge University Press, 1971), p. 25. Reprinted by permission.

$$C_{st} = \frac{100}{1 + \left(\frac{z}{0.21}\right)}$$

$$LFL = 0.55C_{st} = \frac{0.55(100)}{4.76m + 1.19x - 2.38y + 1}$$

$$UFL = 3.50C_{st} = \frac{3.50(100)}{4.76m + 1.19x - 2.38y + 1}$$

$$LFL_{mix} = \frac{1}{\sum_{i=1}^n \frac{y_i}{LFL_i}}$$

$$UFL_{mix} = \frac{1}{\sum_{i=1}^n \frac{y_i}{UFL_i}}$$

$$\langle C \rangle(x, y, z) = \frac{Q_m}{\pi \sigma_y \sigma_z u} \exp \left[-\frac{1}{2} \left(\frac{y^2}{\sigma_y^2} + \frac{z^2}{\sigma_z^2} \right) \right]$$

$$\langle C \rangle(x, y, z) = \frac{Q_m}{2\pi \sigma_y \sigma_z u} \exp \left[-\frac{1}{2} \left(\frac{y}{\sigma_y} \right)^2 \right] \times \left\{ \exp \left[-\frac{1}{2} \left(\frac{z - H_r}{\sigma_z} \right)^2 \right] + \exp \left[-\frac{1}{2} \left(\frac{z + H_r}{\sigma_z} \right)^2 \right] \right\}$$

$$\langle C \rangle_{max} = \frac{2Q_m}{e\pi u H_r^2} \left(\frac{\sigma_z}{\sigma_y} \right)$$

$$\sigma_z = \frac{H_r}{\sqrt{2}}$$

$$\Delta H_r = \frac{\bar{u}_s d}{u} \left[1.5 + 2.68 \times 10^{-3} Pd \left(\frac{T_s - T_a}{T_s} \right) \right]$$

$$\langle C \rangle(x, y, 0) = \frac{Q_m}{\pi \sigma_y \sigma_z u} \exp \left[-\frac{1}{2} \left(\frac{y}{\sigma_y} \right)^2 - \frac{1}{2} \left(\frac{H_r}{\sigma_z} \right)^2 \right]$$

$$1 \text{ bar} = 1 \times 10^5 \text{ Pa}$$

$$\frac{p_o}{p_a} = \frac{1616 \left[1 + \left(\frac{z_e}{4.5} \right)^2 \right]}{\sqrt{1 + \left(\frac{z_e}{0.048} \right)^2} \sqrt{1 + \left(\frac{z_e}{0.32} \right)^2} \sqrt{1 + \left(\frac{z_e}{1.35} \right)^2}}$$

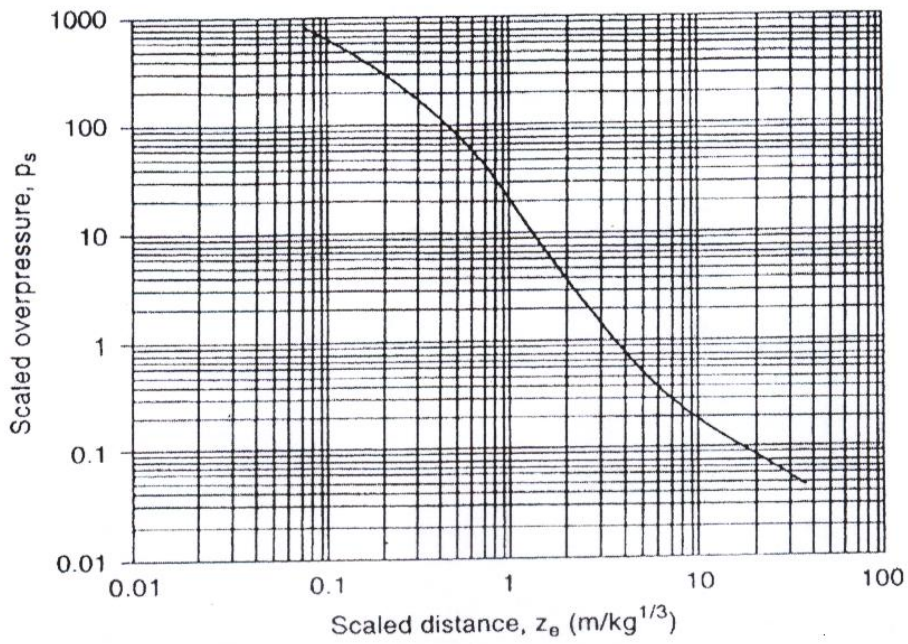

Correlation between scaled distance and explosion peak side-on overpressure for a TNT explosion occurring on a flat surface. Source: G. F. Kinney and K. J. Graham, *Explosive Shocks in Air* (Berlin: Springer-Verlag, 1985).

Atmospheric Stability Classes for Use with the Pasquill-Gifford Dispersion Model^{1,2}

Surface wind speed (m/s)	Daytime insolation ³			Nighttime conditions ⁴	
	Strong	Moderate	Slight	Thin overcast or >4/8 low cloud	≤3/8 cloudiness
<2	A	A-B	B	F ⁵	F ⁵
2-3	A-B	B	C	E	F
3-4	B	B-C	C	D ⁶	E
4-6	C	C-D	D ⁶	D ⁶	D ⁶
>6	C	D ⁶	D ⁶	D ⁶	D ⁶

Stability classes:

- A, extremely unstable
- B, moderately unstable
- C, slightly unstable
- D, neutrally stable
- E, slightly stable
- F, moderately stable

¹F. A. Gifford, "Use of Routine Meteorological Observations for Estimating Atmospheric Dispersion," *Nuclear Safety* (1961), 2(4): 47.

²F. A. Gifford, "Turbulent Diffusion-Typing Schemes: A Review," *Nuclear Safety* (1976), 17(1): 68.

³Strong insolation corresponds to a sunny midday in midsummer in England. Slight insolation to similar conditions in midwinter.

⁴Night refers to the period 1 hour before sunset and 1 hour after dawn.

⁵These values are filled in to complete the table.

⁶The neutral category D should be used, regardless of wind speed, for overcast conditions during day or night and for any sky conditions during the hour before or after sunset or sunrise, respectively.

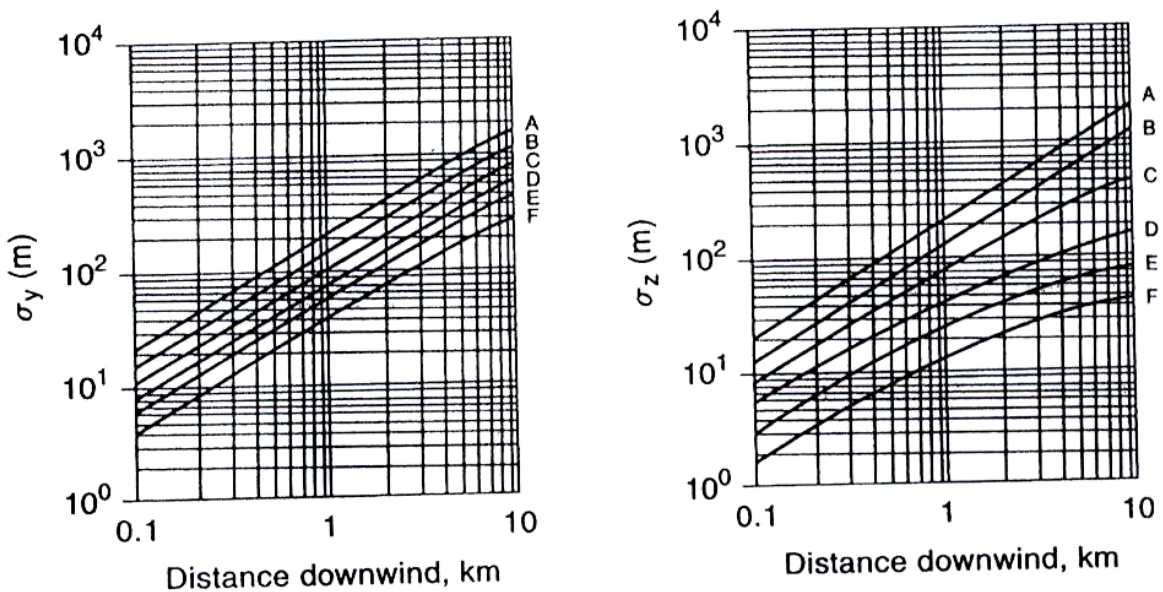

Dispersion coefficients for Pasquill-Gifford plume model for rural releases.

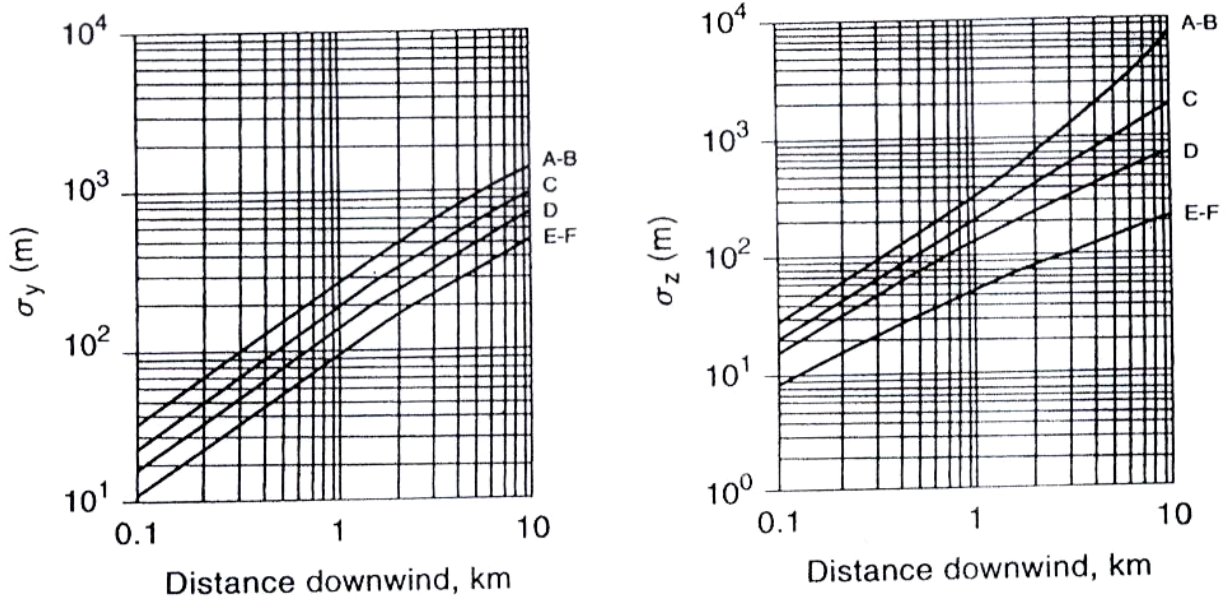

Dispersion coefficients for Pasquill-Gifford plume model for urban releases.

Recommended Equations for Pasquill-Gifford Dispersion Coefficients for Plume Dispersion^{1,2} (the downwind distance x has units of meters)

Pasquill-Gifford stability class	σ_y (m)	σ_z (m)
Rural conditions		
A	$0.22x(1 + 0.0001x)^{-1/2}$	$0.20x$
B	$0.16x(1 + 0.0001x)^{-1/2}$	$0.12x$
C	$0.11x(1 + 0.0001x)^{-1/2}$	$0.08x(1 + 0.0002x)^{-1/2}$
D	$0.08x(1 + 0.0001x)^{-1/2}$	$0.06x(1 + 0.0015x)^{-1/2}$
E	$0.06x(1 + 0.0001x)^{-1/2}$	$0.03x(1 + 0.0003x)^{-1}$
F	$0.04x(1 + 0.0001x)^{-1/2}$	$0.016x(1 + 0.0003x)^{-1}$
Urban conditions		
A-B	$0.32x(1 + 0.0004x)^{-1/2}$	$0.24x(1 + 0.0001x)^{1/2}$
C	$0.22x(1 + 0.0004x)^{-1/2}$	$0.20x$
D	$0.16x(1 + 0.0004x)^{-1/2}$	$0.14x(1 + 0.0003x)^{-1/2}$
E-F	$0.11x(1 + 0.0004x)^{-1/2}$	$0.08x(1 + 0.0015x)^{-1/2}$

A-F are defined in Table 5-1.

¹R. F. Griffiths, "Errors in the Use of the Briggs Parameterization for Atmospheric Dispersion Coefficients," *Atmospheric Environment* (1994), 28(17): 2861-2865.

²G. A. Briggs, *Diffusion Estimation for Small Emissions*, Report ATDL-106 (Washington, DC: Air Resources, Atmospheric Turbulence, and Diffusion Laboratory, Environmental Research Laboratories, 1974).

Damage Estimates for Common Structures Based on Overpressure (these values are approximations)¹

Pressure		Damage
psig	kPa	
0.02	0.14	Annoying noise (137 dB if of low frequency, 10–15 Hz)
0.03	0.21	Occasional breaking of large glass windows already under strain
0.04	0.28	Loud noise (143 dB), sonic boom, glass failure
0.1	0.69	Breakage of small windows under strain
0.15	1.03	Typical pressure for glass breakage
0.3	2.07	“Safe distance” (probability 0.95 of no serious damage below this value); projectile limit; some damage to house ceilings; 10% window glass broken
0.4	2.76	Limited minor structural damage
0.5–1.0	3.4–6.9	Large and small windows usually shatter; occasional damage to window frames
0.7	4.8	Minor damage to house structures
1.0	6.9	Partial demolition of houses, made uninhabitable
1–2	6.9–13.8	Corrugated asbestos shatters; corrugated steel or aluminum panels, fastenings fail, followed by buckling; wood panels (standard housing), fastenings fail, panels blow in
1.3	9.0	Steel frame of clad building slightly distorted
2	13.8	Partial collapse of walls and roofs of houses
2–3	13.8–20.7	Concrete or cinder block walls, not reinforced, shatter
2.3	15.8	Lower limit of serious structural damage
2.5	17.2	50% destruction of brickwork of houses
3	20.7	Heavy machines (3000 lb) in industrial buildings suffer little damage; steel frame buildings distort and pull away from foundations
3–4	20.7–27.6	Frameless, self-framing steel panel buildings demolished; rupture of oil storage tanks
4	27.6	Cladding of light industrial buildings ruptures
5	34.5	Wooden utility poles snap; tall hydraulic presses (40,000 lb) in buildings slightly damaged
5–7	34.5–48.2	Nearly complete destruction of houses
7	48.2	Loaded train wagons overturned
7–8	48.2–55.1	Brick panels, 8–12 in thick, not reinforced, fail by shearing or flexure
9	62.0	Loaded train boxcars completely demolished
10	68.9	Probable total destruction of buildings; heavy machine tools (7000 lb) moved and badly damaged, very heavy machine tools (12,000 lb) survive
300	2068	Limit of crater lip

¹V. J. Clancey, “Diagnostic Features of Explosion Damage,” paper presented at the *Sixth International Meeting of Forensic Sciences* (Edinburgh, 1972).

Appendix Q.6.[a].
Apendik S.6.[a].

Nama : _____

Angka Giliran: _____

