UNIVERSITI SAINS MALAYSIA

Peperiksaan Kursus Semasa Cuti Panjang
Sidang Akademik 2007/2008

June 2008

Jun 2008

EMH 102/3 – Fluids Mechanics
Mekanik Bendalir

Duration : 3 hours

Masa : 3 jam

INSTRUCTIONS TO CANDIDATE:

ARAHAN KEPADA CALON :

Please check that this paper contains **SIX (6)** printed pages, **TWO (2)** page appendix and **SIX (6)** questions before you begin the examination.

*Sila pastikan bahawa kertas soalan ini mengandungi **ENAM (6)** mukasurat bercetak, **DUA (2)** mukasurat lampiran dan **ENAM (6)** soalan sebelum anda memulakan peperiksaan.*

Answer **FIVE (5)** questions.

*Jawab **LIMA (5)** soalan.*

Answer all questions in **ENGLISH OR BAHASA MALAYSIA** OR a combination of both.

*Calon boleh menjawab semua soalan dalam **BAHASA MALAYSIA** ATAU **BAHASA INGGERIS** ATAU kombinasi kedua-duanya.*

Each question must begin from a new page.

Setiap soalan mestilah dimulakan pada mukasurat yang baru.

Appendix/Lampiran:

1. Gambarajah Moody [1 page/mukasurat]
2. Jadual sifat-sifat udara dan air [1 page/mukasurat]

- Q1. [a] If 6.5 m^3 of certain oil weighs 55 kN , determine the mass density, specific weight and the specific gravity of the oil.

Jika 6.5 m^3 suatu minyak yang beratnya 55 kN , tentukan ketumpatan jisim, berat tentu dan graviti tentu bagi minyak.

(20 marks/markah)

- [b] The velocity profile of water flow is given by an equation: $u = 10 y^{1/6}$ where u = water velocity (m/s) y = distance from the boundary (mm). Determine the shear stress in the water at $y = 2 \text{ mm}$. (Take the viscosity of water as $1.8 \times 10^{-3} \text{ Ns/m}^2$).

Susuk halaju bagi aliran air diberikan dengan persamaan: $u = 10 y^{1/6}$ di sini u = halaju air (m/s) y = jarak daripada sempadan (mm). Tentukan tegasan ricih di dalam air pada $y = 2 \text{ mm}$. (Ambil kelikatan air sebagai $1.8 \times 10^{-3} \text{ Ns/m}^2$).

(30 marks/markah)

- [c] The manometer measurement as shown in Figure Q1[a] has air at the top, find the difference of pressure between point B and point A, if the mass density of water $\rho = 1000 \text{ kg/m}^3$, $h_1 = 60 \text{ cm}$, $h = 45 \text{ cm}$, and $h_2 = 180 \text{ cm}$.

Pengukuran manometer seperti ditunjukkan dalam Rajah S1[a] mempunyai udara dibahagian atas, tentukan perbezaan tekanan diantara titik B dan titik A, jika ketumpatan jisim air $\rho = 1000 \text{ kg/m}^3$, $h_1 = 60 \text{ cm}$, $h = 45 \text{ cm}$, and $h_2 = 180 \text{ cm}$.

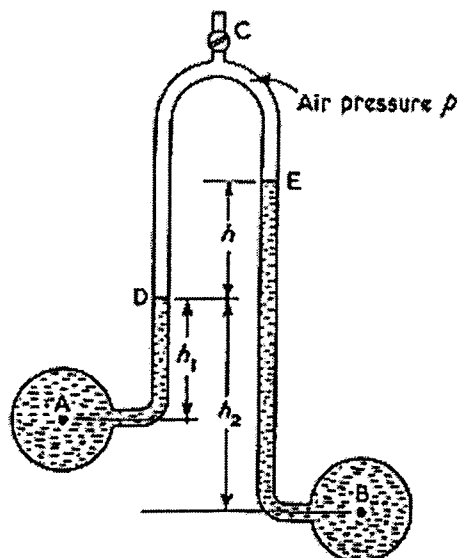

Figure Q1[c]
Rajah S1[c]

(50 marks/markah)

- Q2. [a] A culvert draws off water from the base of a reservoir the sides of which are inclined at 80° to the horizontal Figure Q2[a]. The entrance to the culvert is closed by a circular gate 1.25 m in diameter where can be rotated about its horizontal diameter. Determine the moment needed to open the gate.

Sebuah kulvet mengalirkan air keluar daripada dasar sebuah takungan bersisi yang mana menaik pada 80° kepada mengufuk Rajah S2[a]. Salur masuk kulvet ditutup dengan sebuah pintu bergaris pusat 1.25 m yang mana boleh diputar pada garis pusat mengufuk. Tentukan momen yang diperlukan bagi membuka pintu.

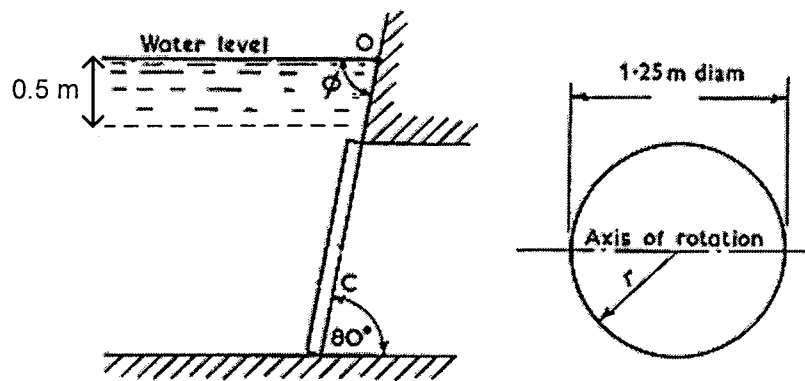

Figure Q2[a]
Rajah S2[a]

(50 marks/markah)

- [b] A rectangular pontoon of mass 90 metric tons is floating in seawater. It is 12 m long, 7.5 m wide and 3 m deep. Seawater has a density of 1025 kg/m^3 and the center of gravity of the pontoon may be taken at its geometrical center. Find the metacentric height.

Sebuah pontoon segiempat yang mempunyai jisim 90 metrik tan terapung diatas air laut. Ia mempunyai panjang 12 m, lebar 7.5 m dan kedalam 3 m. Air laut mempunyai ketumpatan 1025 kg/m^3 dan pusat graviti pontoon boleh diambil pada pusat geometri. Tentukan ketinggian pusat meta.

(50 marks/markah)

- Q3. [a] Given the steady, incompressible velocity distribution $V = 3x\hat{i} + Cy\hat{j} + 0\hat{k}$ where C is a constant. If conservation of mass is satisfied, calculate the value of C.

Diberi agihan halaju mantap, tak boleh mampat $V = 3x\hat{i} + Cy\hat{j} + 0\hat{k}$ di sini C ialah pemalar. Jika keabadian jisim dipatuhi, kirakan nilai C.

(30 marks/markah)

- [b] For a certain two-dimensional flow field the velocity is given by the equation $V = 4xy\hat{i} + 2(x^2 - y^2)\hat{j}$. Determine whether the flow is rotational or irrotational.

Bagi medan aliran dua-dimensi halaju diberikan dengan persamaan $V = 4xy\hat{i} + 2(x^2 - y^2)\hat{j}$. Tentukan sama ada aliran berputar atau tak berputar.

(20 marks/markah)

- [c] The velocity components in a steady, incompressible, two-dimensional flow field are $u = 2y$, and $v = 4x$. Determine the corresponding stream function and show on a sketch several streamlines. Indicate the direction of flow along the streamlines.

Komponen halaju dalam keadaan mantap, tak boleh mampat, medan aliran dua-dimensi ialah $u = 2y$, dan $v = 4x$. Tentukan fungsi arus dan tunjukkan diatas sebuah lakaran beberapa garis arus. Tandakan arah aliran disepanjang garis arus.

(50 marks/markah)

- Q4. [a] Briefly explain the concept of continuum and their relation with Knudsen number.

Terangkan dengan ringkas konsep kontinum dan hubungannya dengan nombor Knudsen.

(20 marks/markah)

- [b] From Bernoulli's equation determine the relationship between static, dynamic and total pressure in a pipe. How are these quantities measured?

Bermula dengan persamaan Bernoulli tentukan hubungan di antara tekanan statik, dinamik dan total bagi aliran di dalam paip. Bagaimanakah kuantiti-kuantiti ini diukur?

(30 marks/markah)

- [c] A water pipe with cross-sectional area A_1 is fitted concentrically with a sharp-edge orifice of cross-sectional area A_o . Obtain an expression for the discharge Q , of this pipe if the coefficient of discharge, coefficient of velocity and coefficient vena-contracta are C_d , C_v and C_c .

Sebuah paip air dengan luas keratan rentas A_1 dipasangkan dengan sebuah orifis berbucu tajam yang luas keratan rentas A_o . Tentukan ungkapan bagi kadar aliran luahan Q , bagi paip ini jika pemalar luahan, pemalar halaju dan pemalar 'Vena contracta' masing-masing adalah C_d , C_v dan C_c .

(50 marks/markah)

Q5. [a] An oil with a viscosity of 0.4 Ns/m^2 and density of 900 kg/m^3 flows in a steel pipe of diameter $D= 0.02 \text{ m}$. Determine:

- (i) The pressure drop that is needed to produce a flow rate of $2.0 \times 10^{-5} \text{ m}^3/\text{s}$ if the pipe length is 10 m .**
- (ii) How steep a hill, for the oil to flow through the pipe at the same rate.**
- (iii) If the initial pressure is 200 kPa , what is the pressure at section 5 m downstream of the pipe.**

Minyak dengan kelikatan 0.4 Ns/m^2 dan ketumpatan 900 kg/m^3 mengalir didalam sebuah paip keluli bergaris pusat $D= 0.02 \text{ m}$. Tentukan:

- (i) Kejatuhan tekanan diperlukan bagi menghasilkan kadar aliran $2.0 \times 10^{-5} \text{ m}^3/\text{s}$ jika panjang paip ialah 10 m .*
- (ii) Berapakah kecerunan bukit, θ yang mesti bagi paip jika minyak perlu mengalir pada kadar yang sama.*
- (iii) Jika tekanan awal ialah 200 kPa , apakah tekanan di seksyen 5 m hilir paip.*

(60 marks/markah)

[b] Water is discharged from a reservoir into the atmosphere through a galvanized iron pipe 39 m long. There is a sharp entrance to the pipe and the diameter is 50 mm for 15 m from entrance. The pipe is then enlarges suddenly to 75 mm in diameter for the remainder of its length. Calculate the difference of level between the surface of the reservoir and the pipe exit which will maintain a flow of 2.8 l/s .

Air diluahkan daripada takungan ke atmosfera melalui sebuah paip besi galvanik yang panjang 39 m . Paip mempunyai salur masuk yang tajam dan bergaris pusat 50 mm bagi 15 m daripada salur masuk. Paip diperbesarkan secara tiba-tiba kepada garis pusat 75 mm bagi panjang yang selebihnya. Kirakan perbezaan paras diantara permukaan takungan dan salur keluar paip yang akan menetapkan aliran 2.8 l/s .

(40 marks/markah)

- Q6. [a]** A thin rectangular plate having a width w and a height h is located so that it is normal to a moving stream of fluid. Assume the drag, D , that fluids exerts on the plate is a function of w and h , the fluid viscosity and density, are μ and ρ , respectively, and the velocity, of the fluid approaching the plate is V . Determine a suitable set of pi terms to study this problem experimentally.

Sebuah plat segiempat mempunyai lebar w dan tinggi h yang diletakkan supaya normal kepada aliran bendalir. Anggapkan seretan, D bagi bendalir bertindak keatas plat adalah fungsi w dan h , kelikatan dan ketumpatan bendalir masing-masing μ dan ρ , halaju, V , bagi aliran menuju ke plat. Tentukan sebuah kumpulan sebutan pi yang sesuai bagi mengkaji masalah ini secara eksperimen.

(50 marks/markah)

- [b]** The drag on an airplane cruising at 380 km/h in standard air to be determined from tests on a 1:10 scale model placed in pressurized wind tunnel. To minimize compressibility effects, the airspeed in the wind tunnel is also to be 380 km/h. Determine the required air pressure in the tunnel (assuming the same air temperature for model and prototype), and the drag on the prototype corresponding to a measured force of 5 N on the model.

Seretan keatas sebuah kapal terbang terbang pada 380 km/j pada udara piawai boleh ditentukan daripada ujian keatas sebuah model skala 1:10 diletakkan didalam terowong angin bertekanan. Bagi meminimakan kesan kebolehmampatan, kelajuan udara didalam terowong angin juga 380 km/j. Tentukan tekanan udara yang dikehendaki didalam terowong (anggapkan suhu udara adalah sama bagi model dan prototaip), dan seretan keatas protaip bersamaan dengan daya ukuran 5 N keatas model.

(50 marks/markah)

Gambarajah Moody

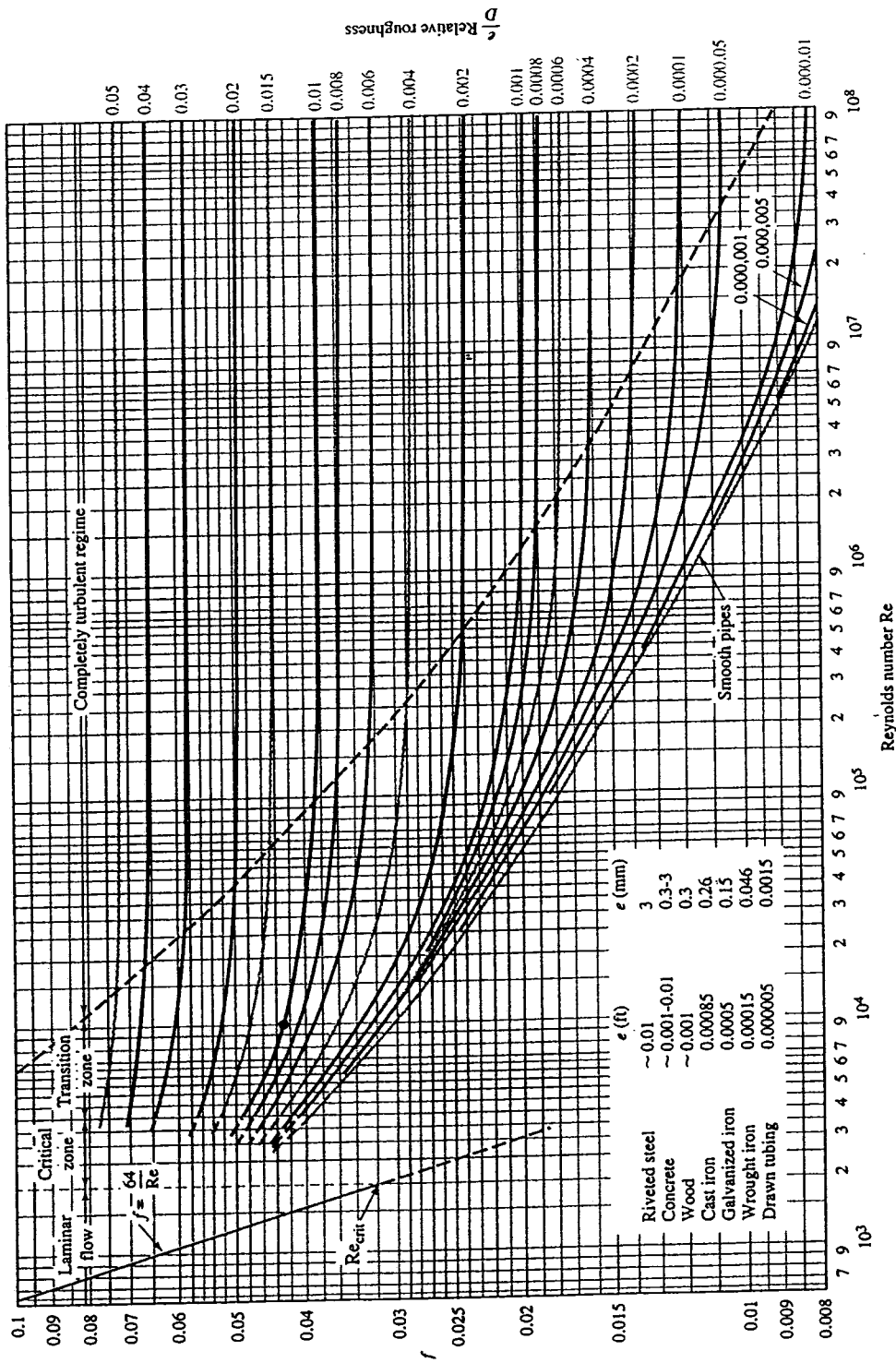

Moody diagram. (From L. F. Moody, *Trans. ASME*, Vol. 66, 1944.) (Note: If $e/D = 0.006$ and $Re = 10^4$, the dot locates $f = 0.043$.)

Jadual Sifat-Sifat Udara dan Air

Properties of Water

Temperature (°C)	Density ρ (kg/m ³)	Specific weight γ (N/m ³)	Viscosity μ (N · s/m ²)	Kinematic viscosity ν (m ² /s)	Bulk modulus B (Pa)	Surface tension σ (N/m)	Vapor pressure, (kPa)
0	999.9	9809	1.792×10^{-3}	1.792×10^{-6}	204×10^7	7.62×10^{-2}	0.610
5	1000.0	9810	1.519	1.519	206	7.54	0.872
10	999.7	9807	1.308	1.308	211	7.48	1.13
15	999.1	9801	1.140	1.141	214	7.41	1.60
20	998.2	9792	1.005	1.007	220	7.36	2.34
30	995.7	9768	0.801	0.804	223	7.18	4.24
40	992.2	9733	0.656	0.661	227	7.01	7.38
50	988.1	9693	0.549	0.556	230	6.82	12.3
60	983.2	9645	0.469	0.477	228	6.68	19.9
70	977.8	9592	0.406	0.415	225	6.50	31.2
80	971.8	9533	0.357	0.367	221	6.30	47.3
90	965.3	9470	0.317	0.328	216	6.12	70.1
100	958.4	9402	0.284×10^{-3}	0.296×10^{-6}	207×10^7	5.94×10^{-2}	101.3

Properties of Air at Atmospheric Pressure

Temperature T (°C)	Density ρ (kg/m ³)	Viscosity μ (N · s/m ²)	Kinematic viscosity ν (m ² /s)	Speed of sound c (m/s)
-30	1.452	1.56×10^{-5}	1.08×10^{-5}	312
-20	1.394	1.61	1.16	319
-10	1.342	1.67	1.24	325
0	1.292	1.72	1.33	331
10	1.247	1.76	1.42	337
20	1.204	1.81	1.51	343
30	1.164	1.86	1.60	349
40	1.127	1.91	1.69	355
50	1.092	1.95	1.79	360
60	1.060	2.00	1.89	366
70	1.030	2.05	1.99	371
80	1.000	2.09	2.09	377
90	0.973	2.13	2.19	382
100	0.946	2.17	2.30	387
200	0.746	2.57	3.45	436
300	0.616	2.93×10^{-5}	4.75×10^{-5}	480