

UNIVERSITI SAINS MALAYSIA

Peperiksaan Semester Pertama
Sidang Akademik 1997/98

September 1997

EKC 430 Keselamatan Loji

Masa: [3 jam]

ARAHAN KEPADA CALON:

Sila pastikan soalan peperiksaan ini mengandungi **TUJUH (7)** mukasurat bercetak dan **SEMBILAN (9)** Lampiran sebelum anda memulakan peperiksaan.

Kertas soalan ini mengandungi **LIMA (5)** soalan.

Jawab mana-mana **EMPAT (4)** soalan.

SATU (1) soalan **MESTI** dijawab di dalam Bahasa Malaysia.

...2/-

1. Gas klorin dibekalkan melalui talian berdiameter dalam 12.5 mm pada tekanan tolok 3.5×10^5 Pa. Talian itu telah pecah pada satu titik berhampiran paras tanah lalu mengeluarkan klorin. Cuaca hari itu adalah cerah pada suhu 30°C dengan kelajuan angin 2.5 m/s. Kawasan perumahan terletak pada kedudukan 750 m dari punca kebocoran klorin.

Chlorine gas is supplied to a processing unit by a 12.5 mm i.d. line at a gauge pressure 3.5×10^5 Pa. The line ruptures at one point releasing chlorine near the ground level. It was a clear day with 2.5 m/s wind at a temperature 30°C . A residential area is 750 m away from the source of chlorine leakage.

Kirakan *Calculate:*

- [a] Tekanan cekik gas tersebut melalui paip itu.
The choked pressure of chlorine through the pipe. (5 markah)
- [b] Kadar pelepasan gas klorin. Anggap pada keadaan terburuk.
The release rate of chlorine gas. Assume the worst condition. (5 markah)
- [c] Masa yang diperlukan untuk awan klorin itu untuk sampai ke kawasan perumahan berhampiran.
The time required for the chlorine cloud to reach the residential area. (3 markah)
- [d] Kepekatan klorin apabila ia sampai di kawasan perumahan itu.
The concentration of chlorine as it reaches the residential area. (6 markah)
- [e] Jarak perjalanan awan klorin untuk mencapai kepekatan TLV (1.5 mg/m^3).
The distance the cloud must travel to reach the TLV concentration (1.5 mg/m^3). (6 markah)

2. [a] Kirakan kepekatan minimum oksigen (MOC) yang diperlukan untuk menghalang pencucuhan campuran 3% metana, 2% propana dan 1% butana.

Calculate the minimum oxygen concentration (MOC) needed to prevent the ignition of a mixture of 3% methane, 2% propane and 1% butane.

(9 markah)

- [b] Semasa memunggah setong silinder gas ke sebuah rumah, seorang pemuda telah menjatuhkan tong itu dengan secara tidak sengaja lalu ia pecah dan mengeluarkan semua gas propana. Awan gas tersebut terbentuk lalu tercucuh. Terdapat beberapa rumah pada jarak 10 hingga 100 meter dari tempat kejadian. Silinder itu mengandungi 20 kg propana.

A man while delivering a gas cylinder to a house accidentally drops, the cylinder, which gets ruptured releasing all the propane. A cloud is formed and gets ignited. There are several houses within 10 to 100 meters of the explosion. The cylinder contained 20 kg of propane.

- [i] Tentukan magnitud letupan itu.

Determine the magnitude of the explosion.

(6 markah)

- [ii] Tentukan sifat kerosakan pada rumah-rumah berhampiran.

Determine the nature of damage to the houses in the vicinity.

(6 markah)

- [iii] Tentukan hentaman (impak) pada jarak 500 meter dari tempat letupan.

Determine the impact 500 meters away from the explosion site.

(4 marks)

3. Rajah Q3 menunjukkan skema penyulingan methanol mentah. Jawab soalan berikutnya:

Figure Q3 shows a scheme for the distillation of crude methanol. Answer to the following:

...4/-

- [a] Tentukan kedudukan alatan pelega.
Determine the location for relief devices. (6 markah)
- [b] Cadangkan jenis alatan pelega pada setiap kedudukan.
Suggest the type of relief devices at each location. (6 markah)
- [c] Berikan beberapa cadangan untuk penahanan pelepasan itu secara keseluruhannya di mana dirasakan berpatutan.
Make recommendations for total containment of the release, where you consider desirable. (6 markah)
- [d] Cadangkan senario pelega untuk setiap kes.
Suggest relief scenerio in each case. (7 markah)

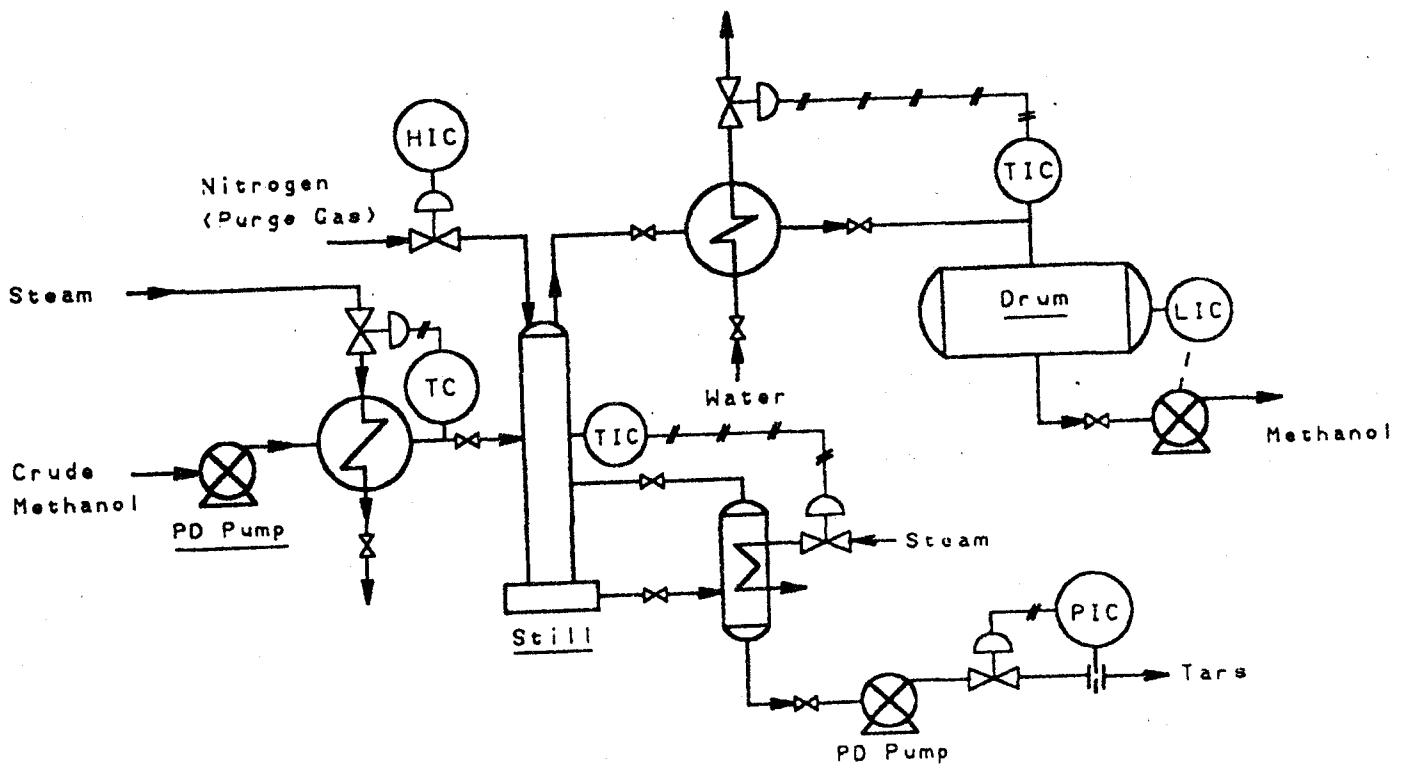

Figure Q3

4. Rajah Q4 menunjukkan satu loji pemanisan hidrokarbon. Pemanisan dilakukan dengan sedikit quantiti udara di mana ianya terlarut keseluruhannya. Kenaikan suhu, peningkatan aliran udara dan penurunan tekanan boleh menghasilkan campuran letupan pada bahagian atas reaktor. Suhu reaktor itu hendaklah rendah daripada suhu titik kilat minyak itu.

Lakukan kajian HAZOP pada sistem di dalam Rajah Q4 dan cadangkan cara untuk memperbaiki keselamatan loji tersebut.

Nota: Jadikan reaktor sebagai asas kajian HAZOP anda.

Figure Q4 shows a hydrocarbon sweetening plant. The sweetening is done by small quantities of air which normally remains completely dissolved. The increase in temperature, decrease in pressure or increase in air flow can give rise to an explosive mixture on the top of the reactor. It is necessary that the temperature of the reactor be lower than the flash point temperature of the oil.

Carry out a HAZOP study for the system in Figure Q4 and suggest ways to improve the safety the plant.

Note: Take the reactor as the base of your HAZOP.

(25 markah)

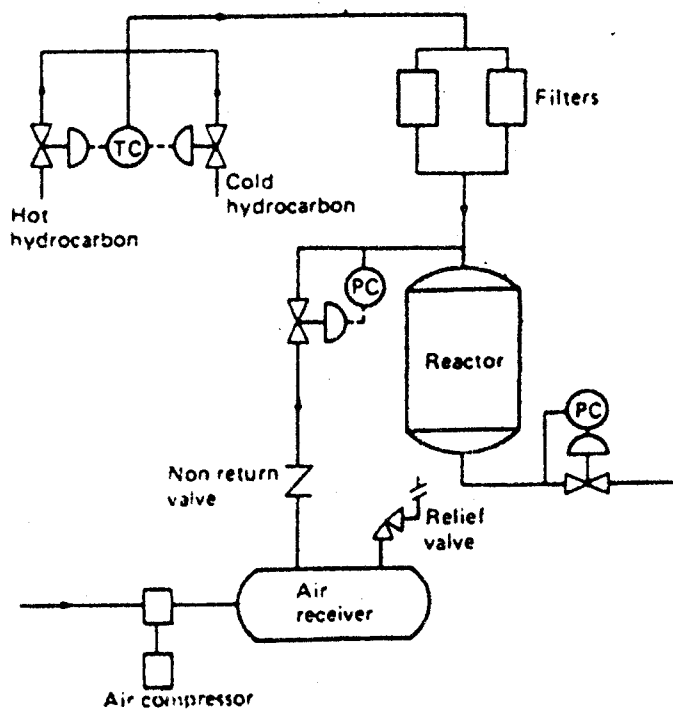

Figure Q4

...6/-

5. Rajah Q5 menunjukkan satu sistem penyejukan gas hidrokarbon di atas platform luar pantai. Penukar haba akan dipiraukan (by-pass) jika suhu masuk (T_1) di bawah 100°C dan air penyejukan akan dimulakan jika suhu melebihi 100°C .

Figure Q5 shows a hydrocarbon gas cooling system in an offshore platform. The heat exchanger is bypassed if the inlet temperature (as measured by T_1) is below 100°C and the cooling water is started if the temperature exceeds 100°C .

- [a] Binakan jaringan kegagalan (fault tree) untuk kejadian teratas "Suhu Gas T_2 melebihi 100°C ".

Construct a fault tree for the top event "Gas Temperature T_2 Exceeds 100°C ".

(10 markah)

- [b] Andaikan kebarangkalian untuk kejadian teratas dalam satu tahun dengan 8,000 jam operasi.

Estimate the probability of the top event in one operating year of 8,000 hours.

(10 markah)

- [c] Komenkan keputusannya dan cadangkan cara untuk memperbaiki sistem itu.

Comment on the result and suggest ways to improve the system.

(5 markah)

Gunakan data dan maklumat di bawah:

Use the following data and information:

Perkara Item	Mean failure rate (per 10^6 hours)
Sensor suhu <i>Temperature sensor</i>	10
Injap pengalih <i>Diverter valve</i>	80
Penukar haba (semua kejadian) <i>Heat exchanger (all causes)</i>	85
Pam centrifugal (semua kejadian) <i>Centrifugal pump (all causes)</i>	150
Unit kawalan <i>Control units</i>	25

...7/-

Kebarangkalian untuk ketiadaan air laut disebabkan penyumbatan paip, injap tidak berfungsi untuk mengubah tutupan dan sebab-sebab lain boleh diambil kira sebagai 0.01 dan kebarangkalian untuk suhu injap hidrokarbon melebihi 100°C ialah 0.5.

The probability of there being no sea water due to line blockage, inadvertent valve closures or other reasons can be taken as 0.01 and the probability of the hydrocarbon inlet temperature exceeding 100°C can be taken as 0.5.

Gunakan formula di bawah untuk pengiraan kebarangkalian:
Use the following formula for probability calculation:

$$P = 1 - e^{-\lambda t}$$

$$P_{A+B} = P_A + P_B - P_A P_B$$

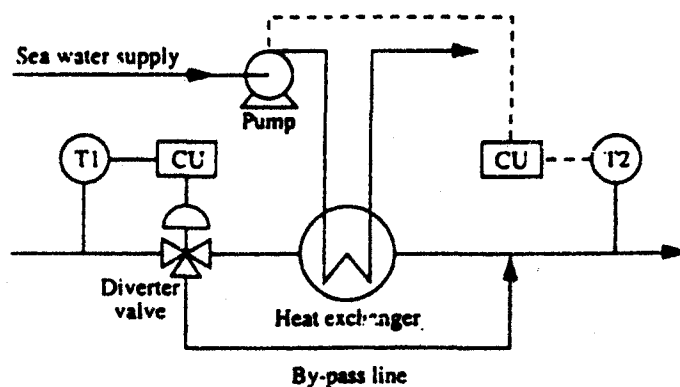

CU = Control Unit

Figure Q5

-0000000-

APPENDIX

1. Mixture TLV - TWA

$$(\text{TLV} - \text{TWA})_{\text{mix}} = \frac{\sum C_i}{\sum_{i=1}^n \frac{C_i}{(\text{TLV} - \text{TWA})_i}}$$

2. Mixture LFL

$$(\text{LFL})_{\text{mix}} = \frac{1}{\sum_{i=1}^n \frac{y_i}{\text{LFL}_i}}$$

3. Minimum Oxygen Concentration, MOC

$$\text{MOL} = \text{LFL} \left(\frac{\text{Moles O}_2}{\text{Moles Fuel}} \right)$$

4. Scaled Distance for overpressure calculations, z_e .

$$z_e = \frac{r}{m^{1/3}_{\text{TNT}}}$$

5. Flow of vapor through a hole

$$Q_m = C_o A P_o \sqrt{\frac{2g_c M}{RgT_o} \frac{\gamma}{\gamma - 1} \left[\left(\frac{P}{P_o} \right)^{2/\gamma} - \left(\frac{P}{P_o} \right)^{(\gamma+1)/\gamma} \right]}$$

$$(Q_m)_{\text{choked}} = C_o A P_o \sqrt{\frac{\gamma g_c M}{RgT_o} \left(\frac{2}{\gamma + 1} \right)^{(\gamma+1)/\gamma}}$$

$$\frac{P_{\text{choked}}}{P_o} = \left(\frac{2}{\gamma + 1} \right)^{\gamma/(\gamma-1)}$$

...2/-

6. Dispersion Model: Continuous plume, steady state, source at ground level, wind moving in x direction at constant velocity.

$$\langle C \rangle (x, y, 0) = \frac{Q_m}{\pi \sigma_y \sigma_z u} \exp \left[-\frac{1}{2} \left(\frac{y}{\sigma_y} \right)^2 \right]$$

$$\langle C \rangle (x, 0, 0) = \frac{Q_m}{\pi \sigma_y \sigma_z u}$$

7. Value of universal gas constant, R_g ($8314 \text{ m}^3 \cdot \text{Pa} / \text{kg mol} \cdot \text{K}$)
8. Value of heat capacity ratio, γ

$$\begin{aligned} \gamma &= 1.67 \text{ for monoatomic gases} \\ &= 1.40 \text{ for diatomic gases} \\ &= 1.32 \text{ for triatomic gases} \end{aligned}$$

9. Value of g_c : $1 \text{ kg} \cdot \text{m} / (\text{N} \cdot \text{s}^2)$
10. Explosion energy of TNT = 4689 J/g

NOTE: ALL NOTATIONS HAVE MEANINGS AS IN YOUR TEXT BOOK.

APPENDIX

- 3 -

Table Standard Enthalpies and Gibbs Energies of Formation at 298.15 K

Joules per mole of the substance formed

Chemical species		State (Note 2)	ΔH_{f298}°	ΔG_{f298}°
Paraffins:				
Methane	CH ₄	(g)	-74,520	-50,460
Ethane	C ₂ H ₆	(g)	-83,820	-31,855
Propane	C ₃ H ₈	(g)	-104,680	-24,290
n-Butane	C ₄ H ₁₀	(g)	-125,790	-16,570
n-Pentane	C ₅ H ₁₂	(g)	-146,760	-8,650
n-Hexane	C ₆ H ₁₄	(g)	-166,920	150
n-Heptane	C ₇ H ₁₆	(g)	-187,780	8,260
n-Octane	C ₈ H ₁₈	(g)	-208,750	16,260
Ammonia	NH ₃	(g)	-46,110	-16,150
Ammonia	NH ₃	(aq)		-26,500
Carbon dioxide	CO ₂	(g)	-393,509	-394,359
Carbon monoxide	CO	(g)	-110,525	-137,169
Sodium carbonate	Na ₂ CO ₃	(s)	-1,130,680	-1,044,440
Sodium carbonate	Na ₂ CO ₃ ·10H ₂ O	(s)	-4,081,320	
Sodium chloride	NaCl	(s)	-411,153	-384,138
Sodium chloride	NaCl	(aq)		-393,133
Sodium hydroxide	NaOH	(s)	-425,609	-379,494
Sodium hydroxide	NaOH	(aq)		-419,150
Sulfur dioxide	SO ₂	(g)	-296,830	-300,194
Sulfur trioxide	SO ₃	(g)	-395,720	-371,060
Sulfur trioxide	SO ₃	(l)	-441,040	
Sulfuric acid	H ₂ SO ₄	(l)	-813,989	-690,003
Sulfuric acia	H ₂ SO ₄	(aq)		-744,530
Water	H ₂ O	(g)	-241,818	-228,572
Water	H ₂ O	(l)	-285,830	-237,129

Atmospheric Stability Classes For Use With The Pasquill-Gifford Dispersion Model

Wind Speed (m/s)	Strong	Day radiation intensity medium	slight	cloudy	Night cloud cover calm & clear
<2	A	A-B	B		
2-3	A-B	B	C	E	F
3-5	B	B-C	C	D	E
5-6	C	C-D	D	D	D
>6	C	D	D	D	D

Stability classes for puff model:

A, B: unstable

C, D: neutral

E, F: stable

TABLE TLVS AND PELS FOR A VARIETY OF CHEMICAL SUBSTANCES

Substance	Threshold Limit Value ¹ Time Weighted Average		OSHA Permissible Exposure Level (PEL)	
	ppm	mg/m ³ , 25°C	ppm	mg/m ³ , 25°C
Acetaldehyde	100	180	100	180
Acetic acid	10	25	10	25
Acetone	750	1780	750	1780
Acrolein	0.1	0.25	0.1	0.25
Acrylic acid (<i>skin</i>)	2	6		
Acrylonitrile* (<i>skin</i>)	2	4.5	2	4.5
Ammonia	25	18	25	18
Aniline (<i>skin</i>)	2	8	2	8
Arsine	0.05	0.2	0.05	0.2
Benzene*	10	30	10	30
Biphenyl	0.2	1.5	0.2	1.5
Bromine	0.1	0.7	0.1	0.7
Butane	800	1900		
Caprolactum (<i>vapor</i>)	0.22	1		
Carbon dioxide	5000	9000	5000	9000
Carbon monoxide	50	55	35	38
Carbon tetrachloride* (<i>skin</i>)	5	30	2	12
Chlorine	0.5	1.5	0.5	1.5
Chloroform*	10	50	2	10
Cyclohexane	300	1015	300	1015
Cyclohexanol (<i>skin</i>)	50	200	50	200
Cyclohexanone (<i>skin</i>)	25	100	25	100
Cyclohexene	300	1010	300	1010
Cyclopentane	600	1720		
Diborane	0.1	0.1	0.1	0.1

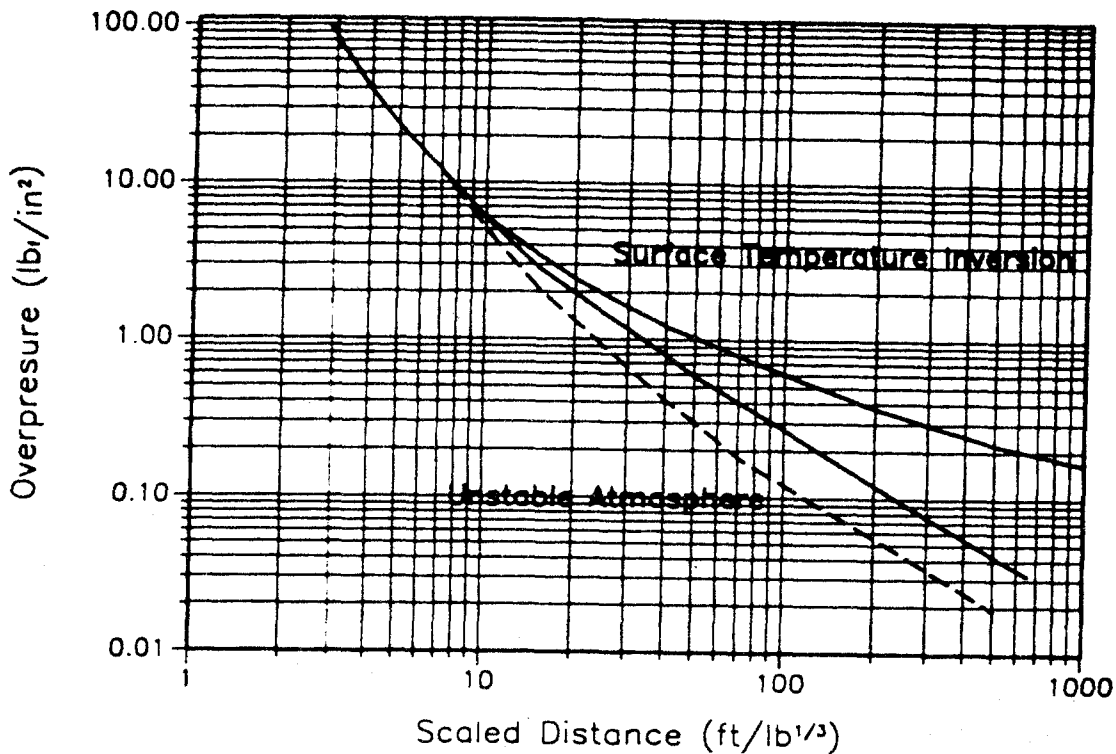

Figure Correlation between overpressure and scaled distance, English engineering units.

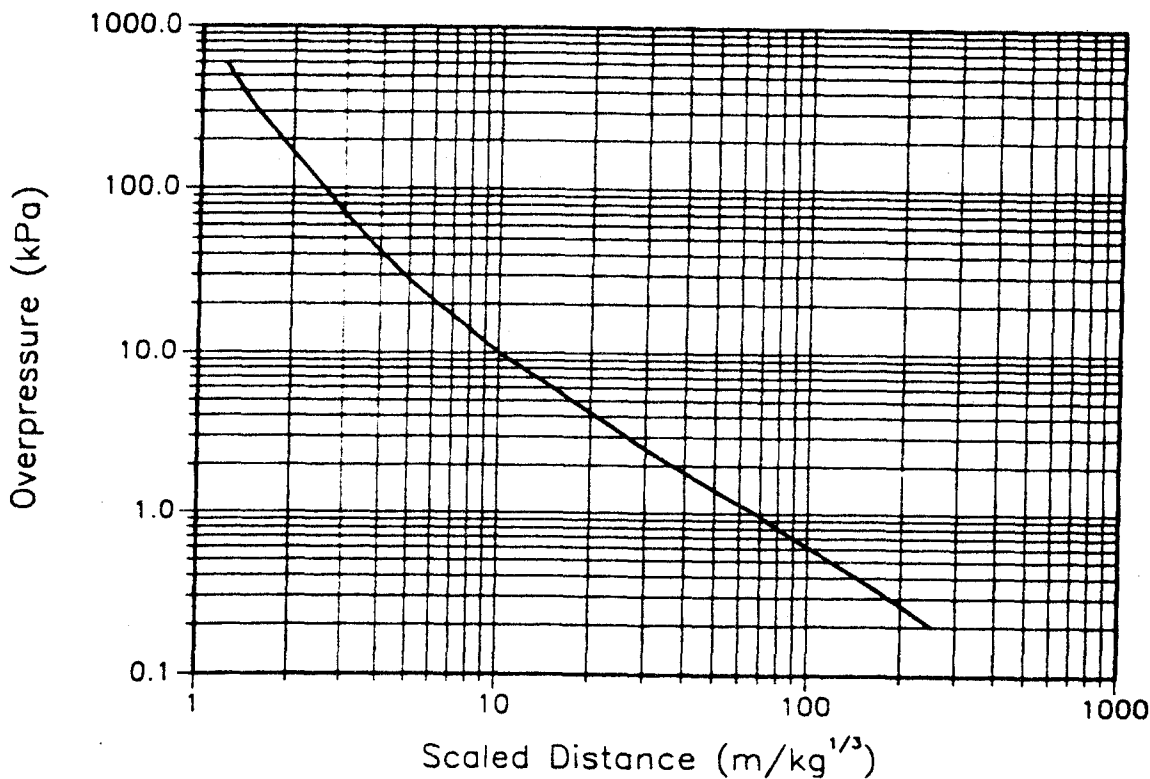

Figure Correlation between overpressure and scaled distance, SI units.

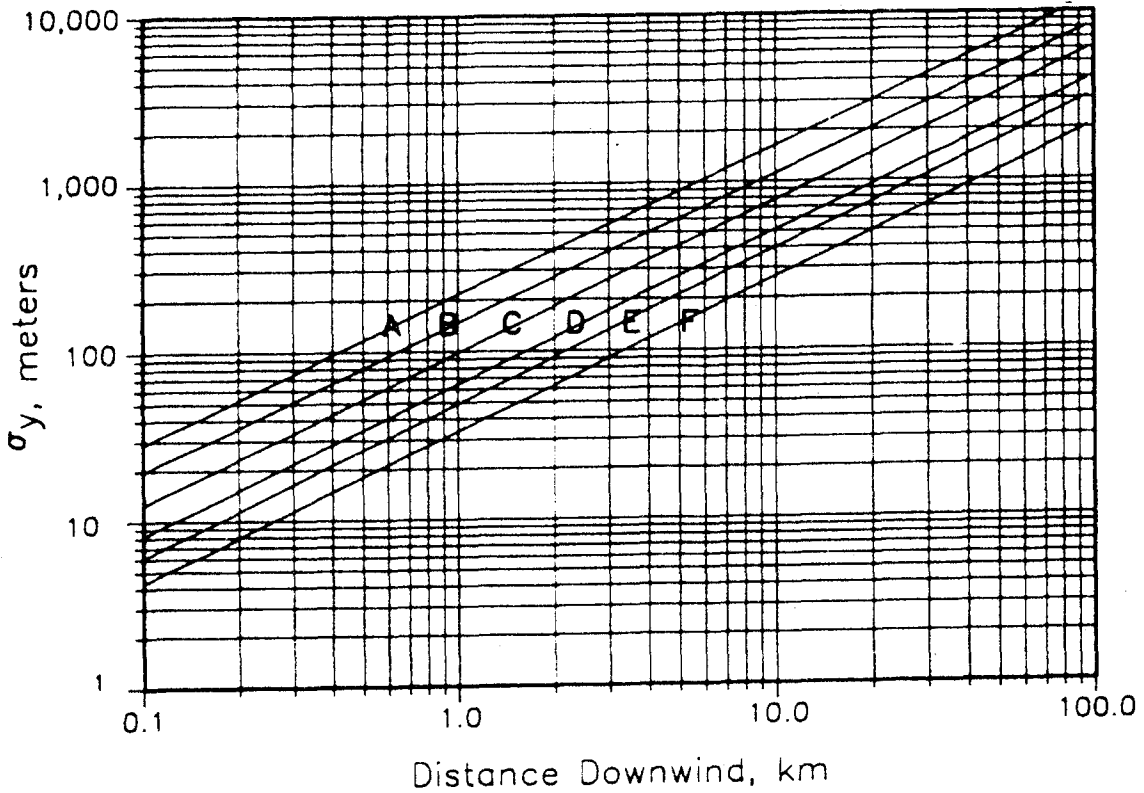

Figure Horizontal dispersion coefficient for Pasquill-Gifford plume model. The dispersion coefficient is a function of distance downwind and the atmospheric stability class.

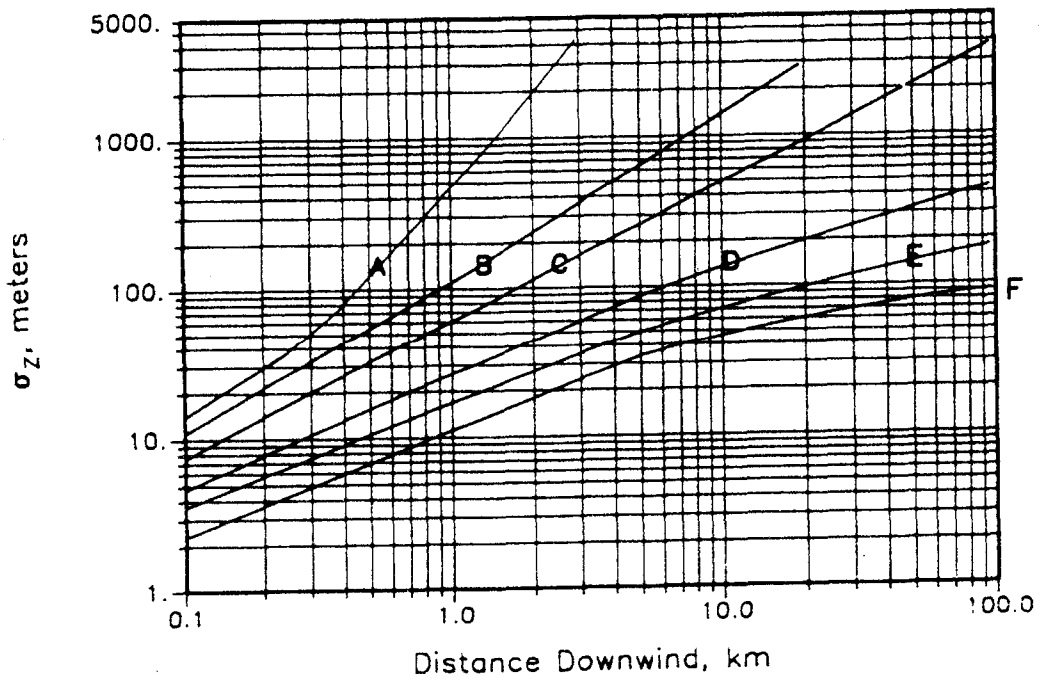

Figure Vertical dispersion coefficient for Pasquill-Gifford plume model. The dispersion coefficient is a function of distance downwind and the atmospheric stability class.

TABLE : DAMAGE PRODUCED BY OVERPRESSURE¹

Overpressure (PSIG)	Damage
0.03	Large glass windows which are already under strain broken.
0.04	Loud noise. Sonic boom glass failure.
0.15	Typical pressure for glass failure.
0.3	95% probability of no serious damage.
0.5-1	Large and small windows usually shattered.
0.7	Minor damage to house structures.
1	Partial demolition of houses, made uninhabitable
1.3	Steel frame of clad building slightly distorted.
2-3	Non-reinforced concrete or cinder walls shattered.
2.3	Lower limit of serious structural damage.
3	Steel frame building distorted and pulled from foundations.
3-4	Rupture of oil storage tanks.
5	Wooden utility poles snapped.
5-7	Nearly complete destruction of houses.
7	Loaded train wagons overturned.
9	Loaded train boxcars completely demolished.
10	Probable total destruction of buildings.
300	Limit of crater lip.

¹V. J. Clancey, "Diagnostic Features of Explosion Damage," *Sixth Int. Mtg. of Forensic Sciences*, Edinburgh (1972).

²⁰W. E. Baker, *Explosions in Air* (Austin: Univ. of Texas Press, 1973); S. Glasstone, *The Effects of Nuclear Weapons* (Washington: U.S. Atomic Energy Comm., 1962).

TABLE FLAMMABILITY CHARACTERISTICS OF LIQUIDS AND GASES¹

Compound	Flash point (°F)	LFL % in air	UFL % in air	Autoignition temperature (°F)
Acetone	0.0*	2.5	13	1000
Acetylene	Gas	2.5	100	
Acrolein	-14.8	2.8	31	
Acrylonitrile	32	3.0	17	
Aniline	158	1.3	11	
Benzene	12.0**	1.3	7.9	1044
Butane	-76	1.6	8.4	761
Carbon monoxide	Gas	12.5	74	
Chlorobenzene	85**	1.3	9.6	1180
Cyclohexane	-1**	1.3	8	473
Diborane	Gas	0.8	88	
Dioxane	53.6	2.0	22	
Ethane	-211	3.0	12.5	959
Ethyl alcohol	55	3.3	19	793
Ethylene	Gas	2.7	36.0	914
Ethylene oxide	-20*	3.0	100	800
Ethyl ether	-49.0**	1.9	36.0	180
Formaldehyde		7.0	73	
Gasoline	-45.4	1.4	7.6	
Heptane	24.8	1.1	6.7	
Hexane	-15	1.1	7.5	500
Hydrogen	Gas	4.0	75	1075
Isopropyl alcohol	53*	2.0	12	850
Isopropyl ether	0	1.4	7.9	830
Methane	-306	5	15	1000
Methyl acetate	15	3.1	16	935
Methyl alcohol	54*	6	36	867
Methyl chloride	32	8.1	17.4	1170
Methyl ethyl ketone	24*	1.4	11.4	960
Methyl isobutyl ketone	73	1.2	8.0	860
Methyl methacrylate	50*	1.7	8.2	790
Methyl propyl ketone	45	1.5	8.2	941
Naptha	-57	1.2	6.0	550
Octane	55.4	1.0	6.5	
Pentane	-40	1.51	7.8	588
Phenol	174	1.8	8.6	
Propane	Gas	2.1	9.5	
Propylene	-162	2.0	11.1	927
Propylene dichloride	61	3.4	14.5	1035
Propylene oxide	-35	2.3	36	869
Styrene	87**	1.1	7.0	914
Toluene	40	1.2	7.1	997

* Open cup flash point
**Closed cup flash point