UNIVERSITI SAINS MALAYSIA

Peperiksaan Semester Pertama
Sidang Akademik 2005/2006

November 2005

IEK 309E – Chemodynamics
[Kimodinamik]

Duration: 3 hours

Masa: 3 jam

Please check that this examination paper consists of SEVEN (7) pages of printed material before you begin the examination.

Answer **FIVE** (5) questions. All questions can be answered either in Bahasa Malaysia or English.

[Sila pastikan bahawa kertas peperiksaan ini mengandungi TUJUH (7) muka surat yang bercetak sebelum anda memulakan peperiksaan ini.]

*[Jawab **LIMA** (5) soalan. Semua soalan boleh dijawab sama ada dalam Bahasa Malaysia atau Bahasa Inggeris.]*

1. (a) Discuss the Conservative substances and the nonconservative substances on the water quality downstream of a point source.
(50 marks)
- (b) Discuss the stagnant-film model, and the penetration theory.
(50 marks)
2. A large hole (> 10 cm) in a carrier causes a high density immiscible liquid to spill into a deep slow moving water body. With the help of a hypothetical spill situation describe and explain the forced convection dissolution phenomenon.
(100 marks)
3. Propanol in the water is being oxidized by a microbial enzyme reaction according to $C_3H_7OH + 4.5O_2 = 3CO_2 + 4H_2O$. The oxygen comes from the air above the water surface. The oxidation of propanol occurs at a constant rate. The rate of disappearance of propanol is $(-r_A) = 3.28 \times 10^{-4}$ mg/L.s. Calculate
- (a) the reaction rate of oxygen consumption (kmol/s) within a m^3 of water located at the surface;
- (b) the molar flux rate of CO_2 (kmol/ m^2 .s) as it desorbs through a m^2 of the water surface.
- The atomic weights of the elements involved are: C = 12, H = 1.008, O = 16
(100 marks)
4. Describe how mass transfer coefficients in the oceanic environment can be measured with the help of a gas exchange simulation apparatus in the laboratory. Highlight the variables involved and discuss some graphical results on the liquid phase coefficient.
(100 marks)

5. The time required for a stream to recover from a hypothetical state of no dissolved oxygen to some final degree of saturation gives an indication of speed of reaeration.

- (a) Calculate the time required for a stream void of oxygen to reach a 50% saturation. This is the oxygen absorption half-life, $\Delta_{O_2} = \Delta^{\circ}_{O_2}/2$, for this particular stream. Find the distance downstream and oxygen concentration;
- (b) Calculate the time required to reach 90% saturation. Find the distance and the concentration.

Stream data: Average velocity $v_w = 0.22$ m/s; average depth $h = 1.9$ m, $D_{(O_2)W} = 1.80 \times 10^{-5}$ cm²/s at 20 °C, temperature of water = 30 °C. The temperature coefficient for the system in the temperature range is $\theta = 1.018$.

$$\rho_{(O_2)W} = \rho^*_{(O_2)W} - [\rho^*_{(O_2)W} - \rho^{\circ}_{(O_2)W}] \exp[-k_{(O_2)W}t/h]$$

$$L = tv_w$$

At 30 °C, $\rho^*_{(O_2)W} = 7.53$ mg O₂/L

$$k_{(O_2)W}/h = [D_{(O_2)W}v_w]^{1/2}/h^{3/2}$$

$$\Delta_{O_2} = \rho^*_{(O_2)W} - \rho_{(O_2)W}$$

$$k_{T1} = k_{T2}\theta^{(T1-T2)}$$

(100 marks)

6. (a) Estimate the half-life of n-hexane in an oil slick of temperature 75 °F. The vapour pressure of n-hexane is 3.0 psia.

$$\text{Log } p_1^* = 1.25 \text{ log } K + 1.60 \quad p_1^* \text{ in atm, } 1 \text{ atm} = 14.7 \text{ lb}_f/\text{in}^2$$

$$x_{1O} = x^{\circ}_{1O}e^{-Kt}$$

(50 marks)

- (b) For a clean, straight natural stream as shown, estimate the volumetric flow rate and the approximate distance to complete mixing for the side bank discharge.

Manning equation: $v = (1.49/n)r_H^{2/3}S_o^{1/2}$

$n = 0.028$

$r_H = \text{hydraulic radius} = S/L_p$

$S_o = \text{slope of the channel bed}$

For a midstream discharge: $L_m = 1.3vb^2/h$

For a side bank discharge: $L_m = 2.6vb^2/h$

1 mi = 5280 ft

(50 marks)

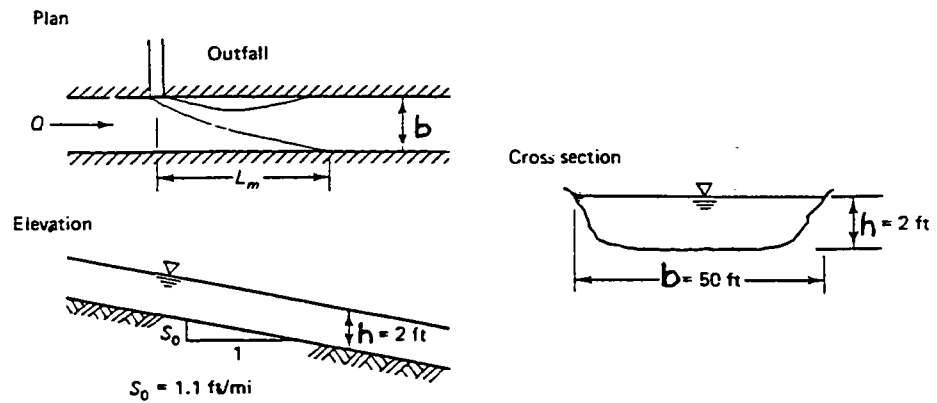

1. (a) *Bincangkan mengenai zat abadi dan zat bukan abadi dalam kualiti air di hilir suatu sumber titik.*
(50 markah)
- (b) *Bincangkan model filem perdiaman, dan teori penusukan.*
(50 markah)
2. *Satu pembukaan besar (> 10 cm) dari suatu kapal menyebabkan satu cecair ketumpatan-tinggi yang takterlarutcampurkan tertumpah ke dalam satu kolam air aliran lambat yang dalam. Dengan bantuan keadaan tumpahan hipotetis, terangkan fenomena pelarutan perolakan paksa.*
(100 markah)
3. *Propanol dioksidakan di dalam air oleh tindak balas enzim microbial menurut: $C_3H_7OH + 4.5O_2 = 3CO_2 + 4H_2O$. Oksigen datangnya daripada udara di atas permukaan air. Pengoksidaan propanol berlaku pada kadar malar. Kadar kehilangan propanol ialah $(-r_A) = 3.28 \times 10^{-4}$ mg/L.s. Hitungkan*
- (a) *kadar tindak balas pengunyahabisan oksigen (kmol/s) di dalam satu m^3 air di permukaan cecair;*
- (b) *kadar fluks molar CO_2 (kmol/ m^2 .s) apabila ia menyahserap menerusi m^2 permukaan air.*
Berat atom bagi unsur: C = 12, H = 1.008, O = 16
(100 markah)
4. *Huraikan bagaimana koefisien-koefisien pemindahan jisim di dalam sekitar laut dapat diukur dengan menggunakan satu radas simulasi pertukaran gas di dalam makmal. Tegaskan pembolehubah-pembolehubah yang terlibat dan bincangkan beberapa keputusan grafik bagi koefisien pemindahan fasa cecair.*
(100 markah)

5. Masa yang dikehendaki untuk satu arus memulih daripada keadaan hipotetis tanpa oksigen terlarut ke hatap akhir ketepuan tertentu memberikan penunjuk mengenai kelajuan pengudaraan semula.

(a) Hitungkan masa yang dikehendaki bagi satu arus yang tiada oksigen untuk mencapai 50% ketepuan. Ini merupakan penyerapan oksigen separuh-hayat, $\Delta_{O_2} = \Delta^{\circ}_{O_2}/2$ bagi arus ini. Carikan jarak di hilir dan kepekatan oksigen.

(b) Hitungkan masa diperlukan untuk mencapai 90% ketepuan. Carikan jarak dan kepekatan seperti soalan (a).

Data arus: Halaju purata, $v_w = 0.22$ m/s; kedalaman purata $h = 1.9$ m; $D_{(O_2)W} = 1.80 \times 10^{-5}$ cm²/s pada 20 °C; suhu air = 30 °C; koefisien suhu bagi sistem dalam julat suhu ialah $\theta = 1.018$.

$$\rho_{(O_2)W} = \rho^*_{(O_2)W} - [\rho^*_{(O_2)W} - \rho^{\circ}_{(O_2)W}] \exp[-k_{(O_2)W}t/h]$$

$$L = tv_w$$

Pada 30°C, $\rho^*_{(O_2)W} = 7.53$ mg O₂/L

$$k_{(O_2)W}/h = [D_{(O_2)W}v_w]^{1/2}/h^{3/2}$$

$$\Delta_{O_2} = \rho^*_{(O_2)W} - \rho_{(O_2)W}$$

$$k_{T1} = k_{T2}\theta^{(T1-T2)}$$

(100 markah)

6. (a) *Anggarkan separuh-hayat bagi n-heksana di dalam satu tompok licin minyak pada 75 °F. Tekanan wap bagi n-heksana ialah 3.0 psia.*

$$\text{Log } p_1^* = 1.25 \log K + 1.60 \quad p_1^* \text{ in atm, } 1 \text{ atm} = 14.7 \text{ lb}_f/\text{in}^2$$

$$x_{10} = x^o 10e^{-Kt}$$

(50 markah)

- (b) *Untuk satu arus semulajadi jernih seperti ditunjukkan, anggarkan kadar aliran volumetrik dan jarak untuk pencampuran sempurna bagi discas tebing.*

Persamaan Manning: $v = (1.49/n)r_H^{2/3}S_o^{1/2}$

$$n = 0.028$$

$$r_H = \text{jejari hidraulik} = S/L_p$$

$$S_o = \text{kelerengan teping}$$

Bagi discas tengaharus: $L_m = 1.3vb^2/h$

Bagi discas tebing: $L_m = 2.6vb^2/h$

$$1 \text{ mi} = 5280 \text{ ft}$$

(50 markah)

