UNIVERSITI SAINS MALAYSIA

Second Semester Examination

Academic Session 2008/2009

April/May 2009

EAS 454/4 – Advanced Structural Engineering
[Kejuruteraan Struktur Lanjutan]

Duration: 3 hours

[Masa : 3 jam]

Please check that this examination paper consists of **FIFTEEN (15)** printed pages including appendix before you begin the examination.

*[Sila pastikan kertas peperiksaan ini mengandungi **LIMA BELAS (15)** muka surat bercetak termasuk lampiran sebelum anda memulakan peperiksaan ini.]*

Instructions: This paper consists of **SIX (6)** questions. Answer **FIVE (5)** questions only. All questions carry the same marks.

*[**Arahan:** Kertas ini mengandungi **ENAM (6)** soalan. Jawab **LIMA (5)** soalan sahaja. Semua soalan membawa jumlah markah yang sama.]*

You may answer the question either in Bahasa Malaysia or English.

[Anda dibenarkan menjawab soalan sama ada dalam Bahasa Malaysia atau Bahasa Inggeris.]

All questions **MUST BE** answered on a new page.

*[Semua soalan **MESTILAH** dijawab pada muka surat baru.]*

Write the answered question numbers on the cover sheet of the answer script.

[Tuliskan nombor soalan yang dijawab di luar kulit buku jawapan anda.]

1. a) Derive the equation of the tensile force, T for a **2 PG** pile cap using truss analogy.
Provide relevant sketch.

[4 Marks]

- b) Design and provide relevant detailing for a pile cap using the given data. Tensile forces in pile caps for some common cases are shown in Appendix A.

i)	Dead Load (service)	= 500 kN
ii)	Live Load (service)	= 250 kN
iii)	Column size	= 300 mm x 300 mm
iv)	Allowable pile working load	= 400 kN
v)	Pile size	= 250 mm spun pile
vi)	Pile spacing	= 750 mm
vii)	Concrete grade / density	= C 35 / 24 kN / mm ²
viii)	Pile cap thickness	= 600 mm
ix)	Pile embedded length	= 75 mm
x)	Main reinforcement	= 20 mm ($f_y = 465 \text{ N/mm}^2$)
xi)	Load eccentricity	= 0 mm
xii)	Edge distance	= 150 mm
xiii)	Concrete cover	= 50mm

[16 Marks]

2. Figure 1 shows a truss supported by pin at node 1, 2 and 4. The truss is subjected to vertical and horizontal forces of 20kN and 40 kN, respectively. AE of all members are 15000 kN. Use stiffness method to solve the following question.

- a) Develop the local stiffness matrices for each member of the truss

[9 Marks]

- b) Develop the global stiffness matrices of the truss

[4 Marks]

- c) Determine internal force of member 1 and state whether the member is in tension or compression.

[7 Marks]

All solutions should be based on member, node and degree of freedom as labeled in Figure 1.

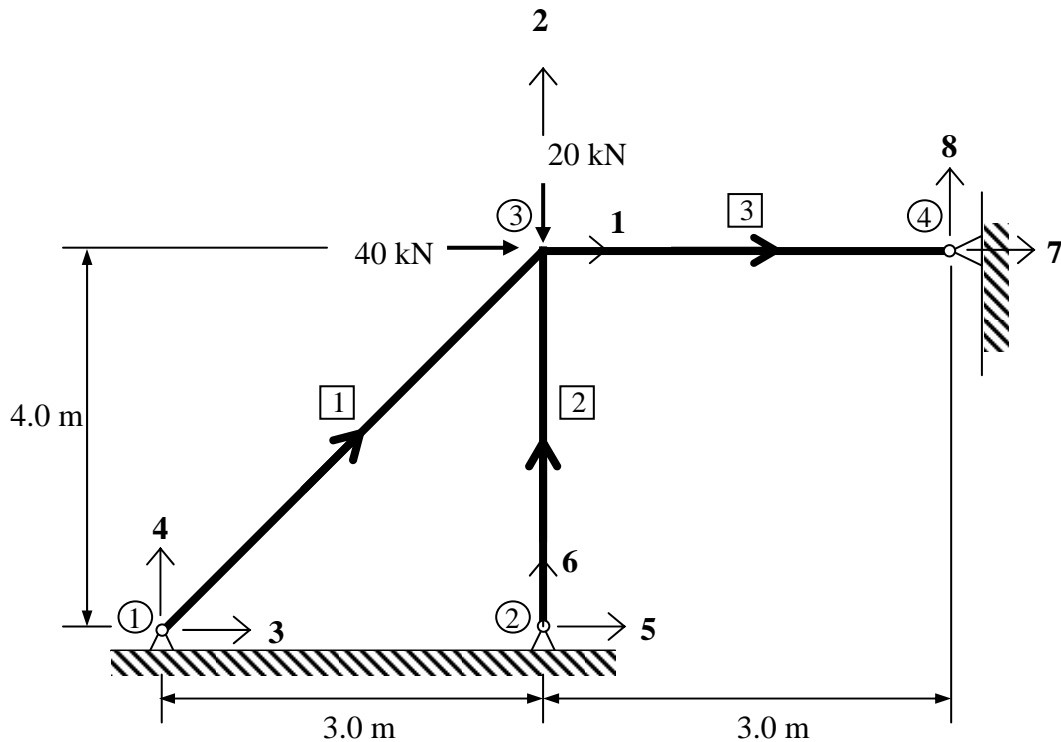

Figure 1

3. a) State the step for calculation according to MS1553 (2002). State any assumptions used. [5 Marks]
- b) A tall building as shown in Figure 2 is situated terrain category 2 with basic wind speed of 32.5 m/s^2 . Calculate the value of design wind pressure on the W(windward) surface at level 15m and 30m. Design data can be extracted from MS1553 (2002). [15 Marks]

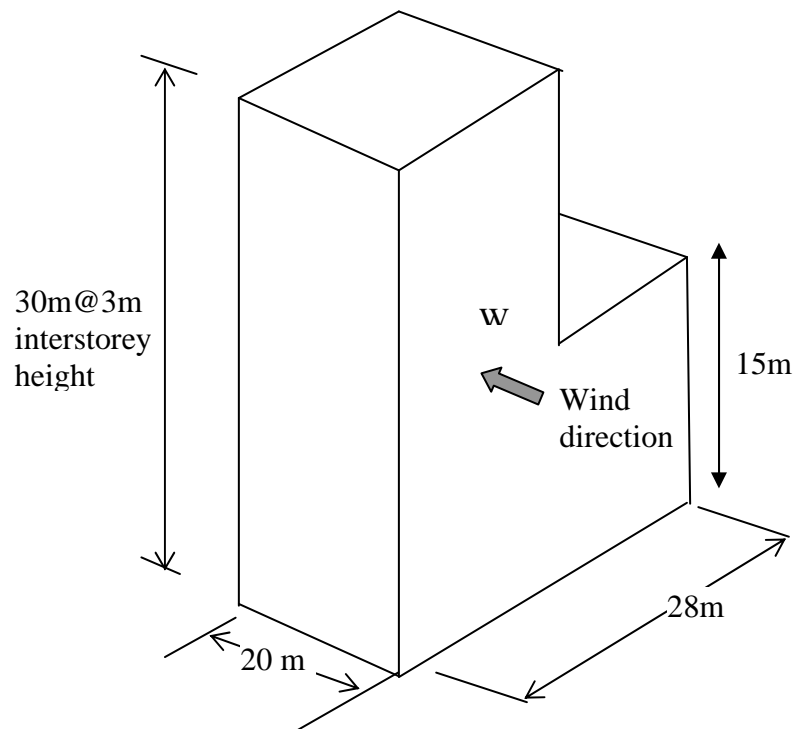

Figure 2

4. a) Briefly explain **THREE (3)** types of floor system in a building.

[3 Marks]

- b) Briefly explain the advantages and disadvantages of wall frame structural system and shear wall structures.

[5 Marks]

- c) Figure 3 shows a continuous beam forming part of the rigid frames. Determine the maximum moment at each supports using two-cycle moment distribution method. Ignore the calculation for the maximum mid-span moments.

[12 Marks]

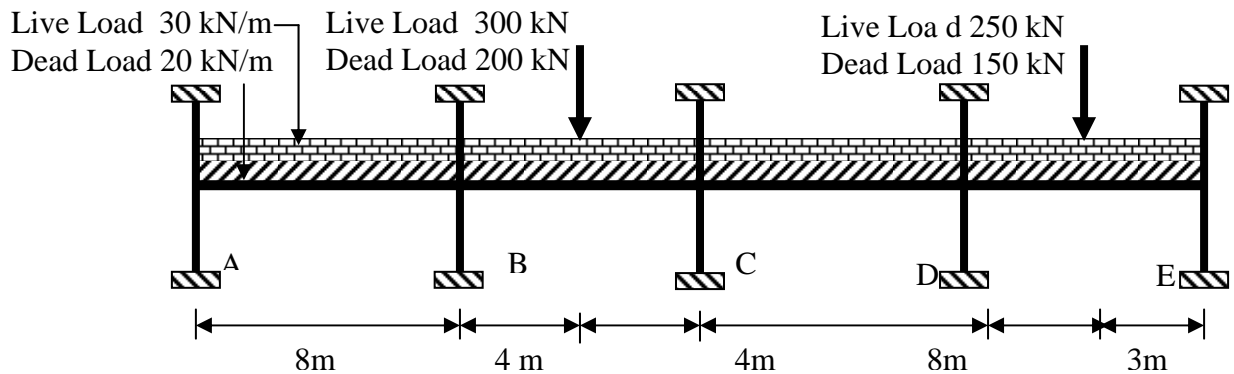

Figure 3

5. a) In finite element displacement method, the critical step is the selection of the element displacement field is a critical step. Give **TWO (2)** requirements for element displacement fields in order to ensure convergence to the exact solution with refinement in element mesh.

[2 Marks]

- b) By using the relation between strain energy U_p and the nodal displacements D_i ($i = 1, 2, 3 \dots, N$) representing the degrees of freedom of an element (where N : number of degree of freedom of an element), explain why a stiffness matrix must be symmetrical for a conservative problem.

[4 Marks]

- c) Figure 4 shows an axially loaded bar element where f^i, f^j : nodal forces at node i and node j , respectively, E : modulus of elasticity of the bar material, A : cross-sectional area of the bar, L : original length of the bar and u^i, u^j : nodal displacement of node i and node j , respectively. Derive the element stiffness matrix using the finite element displacement approach. Show also the relation for evaluating the element stress and give explanation why it is constant for the basic bar element shown in Figure 4.

[14 Marks]

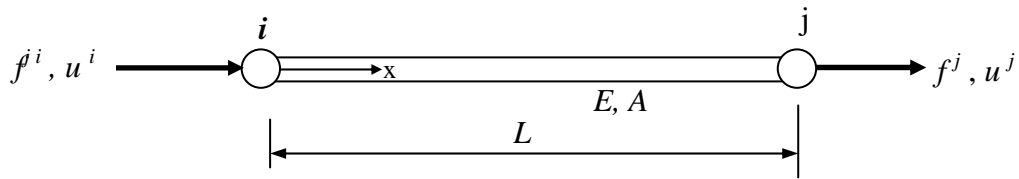

Figure 4

6. a) Derive the equation of motion For the SDOF model shown in Figure 5. Given k : stiffness of the system, c : viscous damping coefficient of the system, m ; mass of the system, $p(t)$: time varying external load acting on the system and $v(t)$: displacement of the system with respect to static equilibrium position.

[6 Marks]

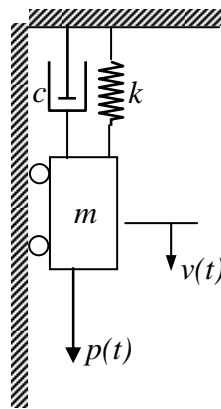

Figure 5

- b) A simply supported beam with span L and flexural rigidity EI is designed to carry a heavy machine with weight W at its mid-span as shown in Figure 6. The machine is supported by two vertical springs with spring constant k . The two springs are connected to a rigid plate which is firmly attached to the beam. The weight of the rigid plate is $0.1W$. By considering the system as shown in Figure 6 as a SDOF system, derive the expression for the equivalent stiffness of the system. Neglect the self-weight of the beam and also the springs. Given that a load P acting at a distance of $L/3$ from support A produces a deflection of $(23/27)PL^3/(48EI)$.

[6 Marks]

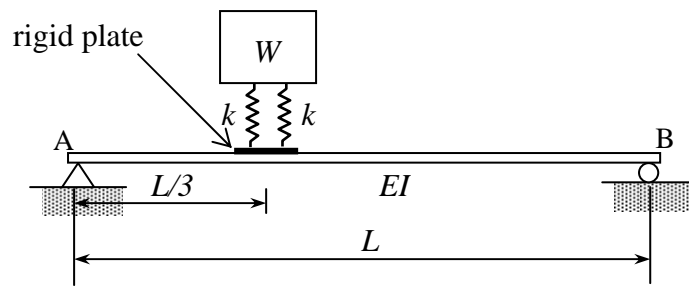

Figure 6

c) A free vibration test has been carried out on the frame as shown in Figure 7. It is found that a lateral jacking force of 100kN produces a 15mm lateral displacement of the girder. When the girder is instantaneously released from this initial position, it is observed that the time recorded for the frame to complete four cycles is 4s and the amplitude of vibration after four cycles is 2.5mm. Based on the data given above and neglecting the mass of the two supporting columns, compute :

- i) Effective weight of the girder W in kN
- ii) Frequency of vibration f in Hertz
- iii) Damping ratio ζ
- iv) Time taken for the amplitude of vibration to decrease to 50% of the initial amplitude

[8 Marks]

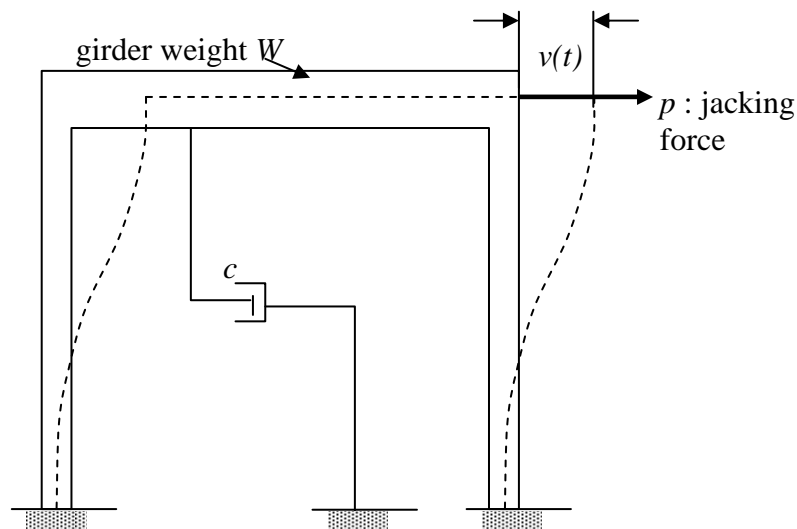

Figure 7

(TERJEMAHAN)

2. a) Terbitkan persamaan daya tegangan, T untuk tetopi cerucuk 2 PG dengan menggunakan analogi kerangka. Sediakan lakaran yang sesuai.

[4 Markah]

- b) Rekabentuk dan sediakan perincian yang berkaitan untuk tetopi cerucuk menggunakan data yang diberikan. Daya tegangan untuk beberapa tetopi cerucuk yang lazim adalah seperti di Lampiran A.

(i)	Beban Mati (kebolehhidmatan)	= 500 kN
(ii)	Beban Hidup (kebolehhidmatan)	= 250 kN
(iii)	Saiz tiang	= 300 mm x 300 mm
(iii)	Beban kerja cerucuk dibenarkan	= 400 kN
(iv)	Saiz cerucuk	= 250 mm cerucuk span
(v)	Selaan cerucuk	= 750 mm
(vi)	Gred konkrit / ketumpatan	= C 35 / 24 kN / mm ²
(vii)	Ketebalan tetopi cerucuk	= 600 mm
(viii)	Kedalaman penusukan cerucuk	= 75 mm
(ix)	Tetulang utama	= 20 mm ($f_y = 465 \text{ N/mm}^2$)
(x)	Kesipian beban	= 0 mm
(xi)	Jarak hujung	= 150 mm
(xii)	Penutup konkrit	= 50mm

[16 Markah]

2. Rajah 1 menunjukkan satu kekuda yang di sokong pin di nod 1, 2 dan 4. Kekuda tersebut menanggung beban tumpu menegak dan mengufuk masing-masing ialah 20kN dan 40 kN. AE untuk semua anggota ialah 15000 kN. Guna kaedah kekukuhan untuk menjawab soalan-soalan berikut.

- a) Bentukkan matrik kekukuhan tempatan untuk setiap anggota kekuda

[9 Markah]

- b) Bentukkan matrik kekukuhan global kekuda tersebut

[4 Markah]

- c) Tentukan daya dalam anggota 1 dan nyatakan samada ia berada dalam keadaan tegangan atau mampatan

[7 Markah]

Penyelesaian yang dibuat mestilah berdasarkan kepada anggota, sambungan dan darjah kebebasan yang telah dilabelkan dalam Rajah 1.

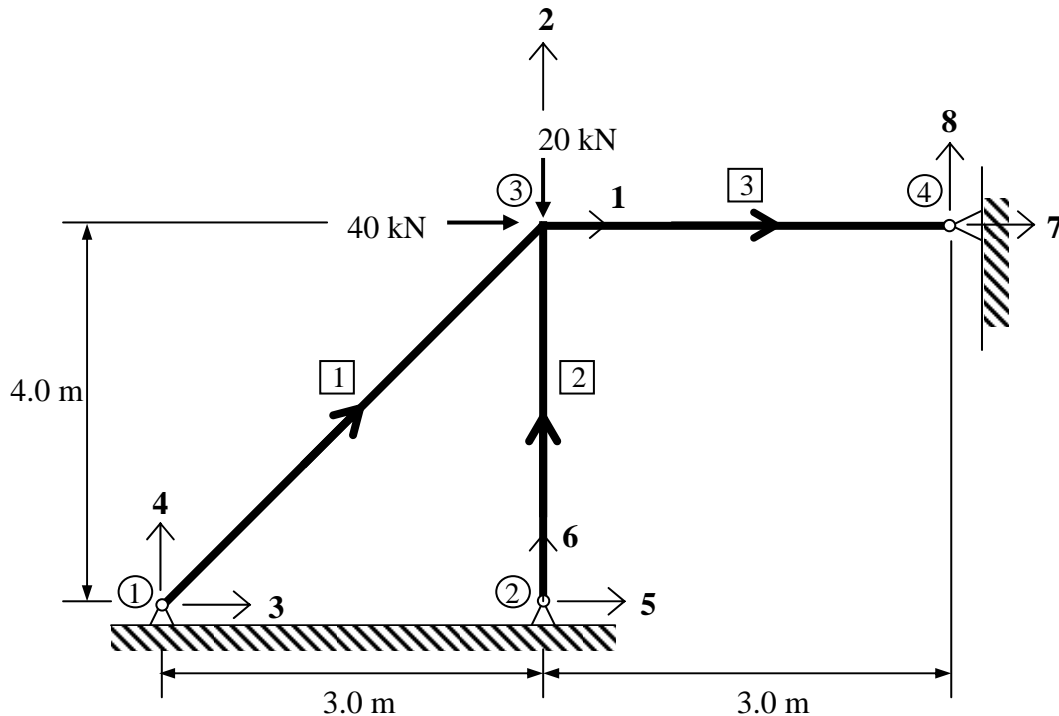

Rajah 1

3. a) Nyatakan langkah pengiraan nilai beban angin berdasarkan MS1553 (2002). Nyatakan sebarang anggapan yang dibuat.

[5 Markah]

- b) Sebuah bangunan tinggi dalam kategori rupa bumi 2 dengan beban angin asas sebanyak 32.5 m/s^2 seperti yang ditunjukkan dalam Rajah 2. Kira nilai tekanan angin rekabentuk di permukaan W(arah angin) di ketinggian 15 m dan 30m. Data rekabentuk boleh diperolehi dari MS1553 (2002).

[15 Markah]

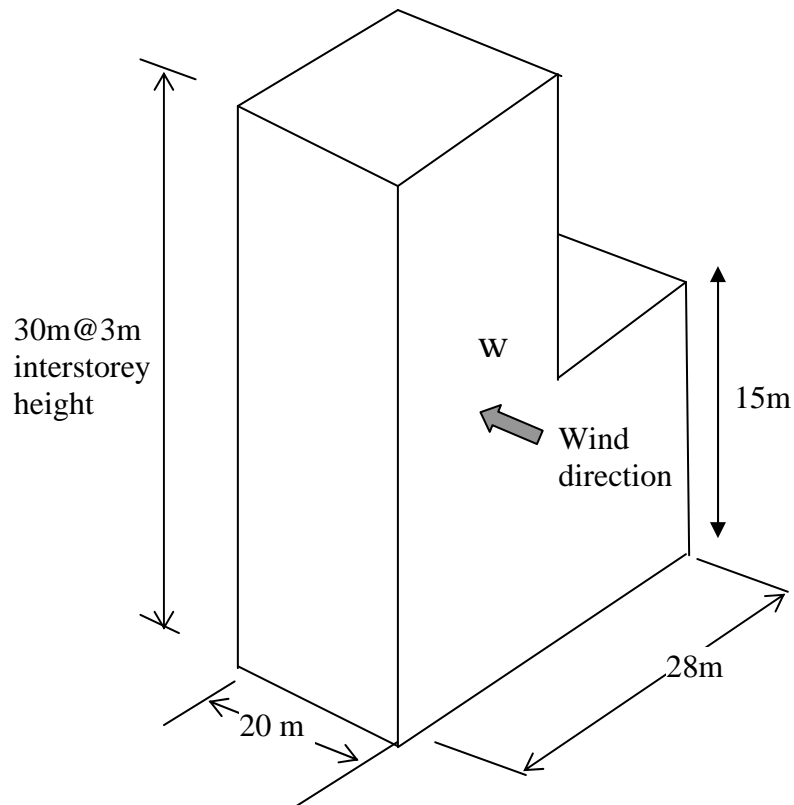
**Rajah 2**

4. a) Terangkan dengan ringkas **TIGA (3)** jenis system papak dalam bangunan.

[3 Markah]

- b) Nyatakan kelebihan dan kekurangan sistem struktur dinding kerangka dan struktur dinding ricih.

[5 Markah]

- c) Rajah 3 menunjukkan satu rasuk selanjur yang membentuk sebahagian dari kerangka tegar. Tentukan nilai momen lentur maksima di setiap penyokong dengan menggunakan kaedah agihan momen dua kitaran. Abaikan pengiraan momen maksima di pertengahan rentang.

[12 Markah]

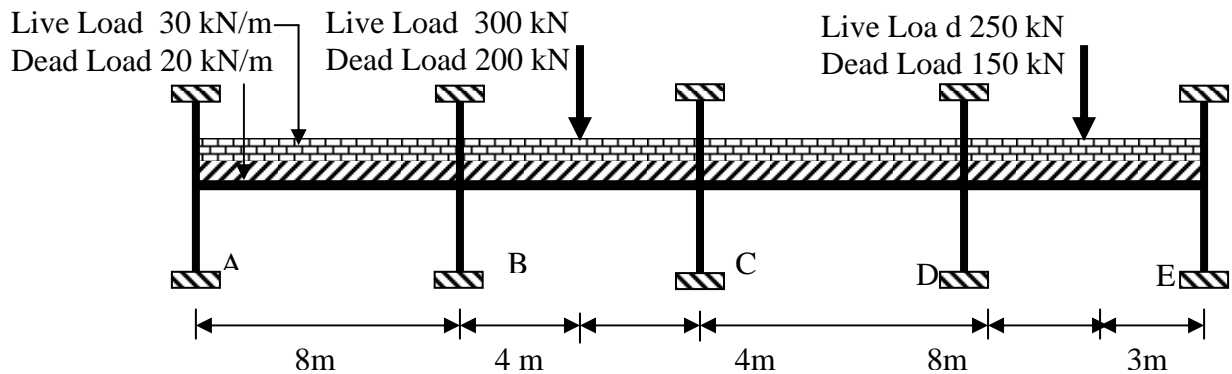

Figure 3

5. a) Dalam kaedah elemen terhingga jenis anjakan, langkah kritikal adalah pemilihan “field” anjakan elemen. Berikan 2 (DUA) keperluan untuk “field” anjakan elemen untuk memastikan bahawa tumpuan kepada penyelesaian betul berlaku dengan penghalusan jaringan elemen.

[2 Markah]

- b) Dengan menggunakan hubungan antara tenaga terikan U_p dan anjakan nod D_i ($i=1,2,3,\dots,N$) yang mewakili darjah kebebasan sesuatu elemen (dimana N :bilangan darjah kebebasan sesuatu elemen), terangkan kenapa matrik kekukuhan elemen mestilah simetri untuk masalah konservatif.

[4 Markah]

- c) Rajah 4 menunjukkan satu elemen bar di bawah tindakan daya paksi, dimana f^i, f^j : daya nod pada nod i dan nod j , E : modulus keanjalan bahan bar, A : luas keratan bar, L : panjang asal elemen bar dan u^i, u^j : anjakan nod pada nod i dan nod j . Terbitkan persamaan kekukuhan elemen dengan menggunakan kaedah elemen terhingga pendekatan anjakan. Tunjukkan juga hubungan untuk pengiraan tegasan elemen dan berikan sebab kenapa tegasan berkenaan adalah malar untuk elemen bar yang ditunjukkan dalam Rajah 4.

[14 Markah]



Figure 4

6. a) Untuk model jisim-pegas SDOF seperti yang ditunjukkan dalam Rajah 5, terbitkan persamaan gerakan yang berkenaan. Diberi bahawa k : kekakuan sistem, m : jisim sistem, $p(t)$: daya luar bertindak yang berubah dengan masa dan $v(t)$: anjakan sistem yang diukur dari kedudukan keseimbangan statik.

[6 Markah]

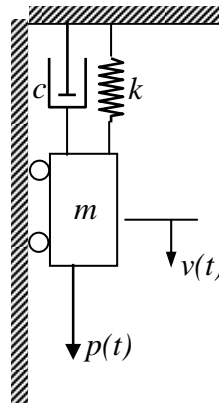

Figure 5

- b) Satu rasuk mudah dengan rentang L dan ketegaran lenturan EI direkabentuk untuk menanggung satu mesin dengan berat W pada kedudukan rentang seperti yang ditunjukkan dalam Rajah 6. Mesin berkenaan disokong oleh dua pegas dengan nilai pemalar pegas k . Kedua-dua pegas kemudiannya disambung ke atas satu plat tegar yang terikat kukuh kepada rasuk. Berat plat tegar adalah $0.1W$. Dengan mempertimbangkan sistem seperti yang ditunjukkan dalam Rajah 6 sebagai satu sistem SDOF, terbitkan persamaan untuk kekakuan setara sistem. Abaikan berat sendiri rasuk dan juga pegas. Diberi bahawa satu daya P yang bertindak pada kedudukan $L/3$ dari penyokong A menghasilkan anjakan pugak bersamaan dengan $(23/27)PL^3/(48EI)$.

[6 Markah]

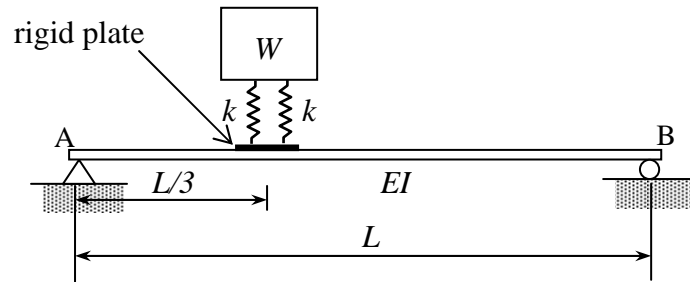

Figure 6

- c) Satu ujian getaran bebas telah dijalankan keatas kerangka yang ditunjukkan dalam Rajah 7. Apabila nilai daya sisi dari “jack” sebanyak 100kN dikenakan ke atas galang kerangka, anjakan sisi galang yang terhasil adalah sebesar 15mm. Apabila galang dilepas dari kedudukan asal di atas, didapati bahawa masa yang diperlukan untuk kerangka melengkapkan empat kitaran adalah 4s dan amplitud getaran selepas empat kitaran adalah sebesar 2.5mm.

Berdasarkan kepada data yang diberikan diatas, kira :

- i) Berat berkesan galang W dalam kN
- ii) Frekuensi getaran f dalam Hertz
- iii) Nisbah redaman ζ
- iv) Masa yang diperlukan untuk amplitud getaran berkurangan sehingga 50% daripada amplitud asal.

[8 Markah]

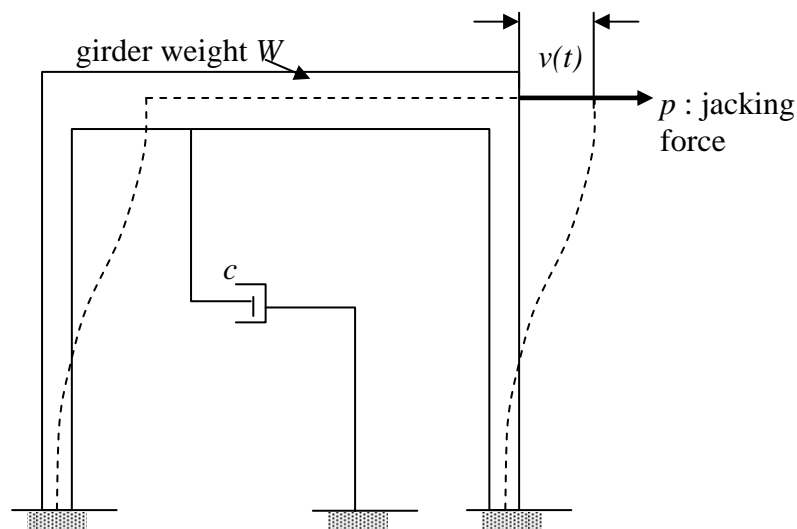

Figure 7

ooOOOoo

APPENDIX A / LAMPIRAN A**Tensile Forces in Pile Caps**

No.	PG	Tensile Force, T
1.	2 PG	$\frac{NL}{2d}$
2.	3 PG	$\frac{2NL}{9d}$
3.	4 PG	$\frac{NL}{4d}$

Notes :-**N = Factored Column Load****L = 0.5 x Pile Spacing****d = Effective Depth****APPENDIX B / LAMPIRAN B**

$$k = \frac{AE}{L} \begin{bmatrix} \lambda_x^2 & \lambda_x \lambda_y & -\lambda_x^2 & -\lambda_x \lambda_y \\ \lambda_x \lambda_y & \lambda_y^2 & -\lambda_x \lambda_y & -\lambda_y^2 \\ -\lambda_x^2 & -\lambda_x \lambda_y & \lambda_x^2 & \lambda_x \lambda_y \\ -\lambda_x \lambda_y & -\lambda_y^2 & \lambda_x \lambda_y & \lambda_y^2 \end{bmatrix}$$

$$\begin{bmatrix} Q_k \\ Q_u \end{bmatrix} = \begin{bmatrix} K_{11} & K_{12} \\ K_{21} & K_{22} \end{bmatrix} \begin{bmatrix} D_u \\ D_k \end{bmatrix}$$

$$q_f = \frac{AE}{L} \begin{bmatrix} -\lambda_x & -\lambda_y & \lambda_x & \lambda_y \end{bmatrix} \begin{bmatrix} D_{N_x} \\ D_{N_y} \\ D_{F_x} \\ D_{F_y} \end{bmatrix}$$

APPENDIX C / LAMPIRAN C

a. Element stiffness matrix of a beam element :

$$k = EI_z \begin{bmatrix} \frac{12}{L^3} & \frac{6}{L^2} & -\frac{12}{L^3} & \frac{6}{L^2} \\ \frac{6}{L^2} & \frac{4}{L} & -\frac{6}{L^2} & \frac{2}{L} \\ \frac{12}{L^3} & \frac{6}{L^2} & -\frac{12}{L^3} & \frac{6}{L^2} \\ -\frac{6}{L^2} & -\frac{4}{L} & \frac{6}{L^2} & -\frac{2}{L} \end{bmatrix}$$

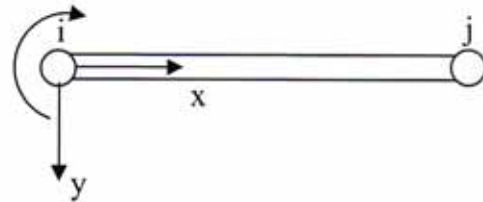

where E : modulus of elasticity, I_z : moment of inertia of section with respect to z -axis (an axis pointing towards the plane of the paper) and L : length of element

b. Fixed end forces

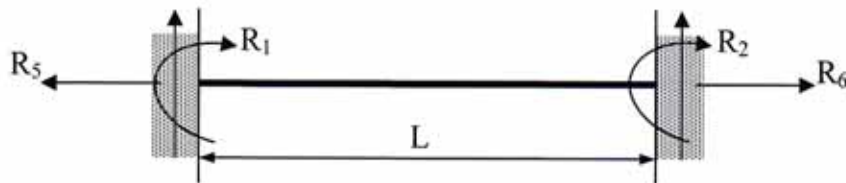

Type of loading	Moments	Vertical forces	Horizontal forces
	$R_1 = -Pab^2/L^2$ $R_2 = -Pa^2b/L^2$	$R_3 = Pb(L^2 + ab - a^2)/L^3$ $R_4 = Pa(L^2 + ab - b^2)/L^3$	$R_5 = 0$ $R_6 = 0$
	$R_1 = -pL^2/12$ $R_2 = pL^2/12$	$R_3 = pL/2$ $R_4 = pL/2$	$R_5 = 0$ $R_6 = 0$