

**DESIGN OF A MICROCONTROLLER-BASED
CONVERTER FOR 3-PHASE BRUSHLESS DC
MOTOR DRIVES**

by

NORKHARZIANA MOHD NAYAN

UNIVERSITI SAINS MALAYSIA

2009

**DESIGN OF A MICROCONTROLLER-BASED CONVERTER FOR
3-PHASE BRUSHLESS DC MOTOR DRIVES**

by

NORKHARZIANA MOHD NAYAN

**Thesis submitted in fulfillment of the requirements for the degree of
Masters of Science**

September 2009

In the name of Allah, the most Compassionate and the Most Merciful;

To my beloved husband, thank you for all your help and advised.

*And to my supportive parents and parents-in-laws, brothers and sisters,
for their love and endless supports.*

ACKNOWLEDGEMENTS

I would like to express my gratitude to my supervisor Dr. Ir Syafrudin Masri and Mr. Muhammad Nasiruddin Mahyuddin for guiding me through with their expertise, and also many thanks to my lab colleagues for their contribution and assistance and fruitful ideas. I further wish to thank all of them who had guided me through all the technical difficulties throughout the project. This research would not have been successful without the valuable guidance and constructive criticisms throughout the research.

I also would like to express my sincere thanks to Mr. Mohd Hafiz Fazalul Rahiman who has provided guidance and helped me through out the research. My thanks also goes to the Dr. Dahaman Ishak, Mr. Mohd Nazir Abdullah and my colleagues Mokhzaini Azizan, Nur Yanti Salleh, Wael Ab. Salah, Saufi, Naim and Anwar, for helping through the discussions and suggestions. Not forgetting our lab technicians, Mr. Ahmad Shaukhi Nor and Mr. Jamaluddin Che Mat, thanks you for their support throughout my lab research.

My special thanks to my husband, for his advice, encouragement and understanding, also thanks to my parents and my parents in-law for their continuous support in going through this research. And to all those who had been supported me in one-way or other during my research. They helped me out far more than they ever realized, their supports are very much appreciated.

Last but not least my obligations and an appreciation go to the Universiti Malaysia Perlis (UniMAP) and Kementerian Pengajian Tinggi (KPT) for providing the scholarships and also to Universiti Sains Malaysia (USM) for allowing me to use their facilities throughout my research.

Norkharziana Mohd Nayan

TABLE OF CONTENTS

	Page
ACKNOWLEDGEMENTS	iii
TABLE OF CONTENTS	iv
LIST OF TABLES	vii
LIST OF FIGURES	viii
LIST OF PLATES	xi
LIST OF SYMBOLS	xii
LIST OF ABBREVIATION	xiii
LIST OF PUBLICATIONS & SEMINARS	xvi
ABSTRAK	xvii
ABSTRACT	xviii

CHAPTER ONE : INTRODUCTION

1.0	Introduction	1
1.1	The Research Aim and Objectives	3
1.2	Problem Statements	4
1.3	Project Contributions	5
1.4	Structure of Thesis	5

CHAPTER TWO : LITERATURE REVIEW

2.0	Introduction	7
2.1	Converter	7
2.1.1	Inverter	7
2.1.2	Three Phase Inverter	8
2.1.3	Voltage and Frequency Control Technique	13
2.1.4	Performance Parameter of an Inverter	14
2.1.5	Filter	15
2.2	Pulse Width Modulation (PWM)	15
2.2.1	Types of PWM	17
2.2.1.1	Single PWM	20
2.2.1.2	Multiple PWM	20
2.2.1.3	Sinusoidal PWM	20

2.2.1.4	Modified Sinusoidal PWM	21
2.3	Power Semiconductor Device	23
2.3.1	MOSFET, IGBT And GTO	23
2.3.2	Gate Driver Circuit	28
2.4	Microcontroller	30
2.5	Brushless DC (BLDC) Motor	33
2.5.1	Motor Characteristics	35
2.5.2	Mathematical Modeling of BLDC Motor	37
2.5.3	Equivalent Circuit of BLDC Motor	38
2.5.4	Advantages and Disadvantages of BLDC Motor	41
2.6	Summary	43

CHAPTER THREE: DESIGN AND DEVELOPMENT OF 3-PHASE INVERTER CIRCUIT FOR BRUSHLESS DC (BLDC) MOTOR DRIVES

3.0	System Block Diagram	45
3.1	Development of Inverter	46
3.1.1	Selection of Power Semiconductor Switches	47
3.1.2	Gate Driver Integration	49
3.1.3	Cooling System	53
3.1.4	Installation	54
3.2	Development of Switching Techniques	56
3.2.1	Switching Strategy	56
3.2.2	Software Development Tools	57
3.2.2.1	microC dsPIC Compiler	57
3.2.2.2	Visual Basic 6.0	59
3.2.3	dsPIC Microcontroller	63
3.2.3.1	The Microcontroller Configurations	64
3.3	Brushless DC (BLDC) Motor	65
3.3.1	BLDC Motor Specifications	65
3.3.2	The Performance of BLDC Motor	67
3.3.3	Excitation Schemes	68
3.4	Summary	68

CHAPTER FOUR : RESULTS AND DISCUSSIONS

4.0	Introduction	70
4.1	The Experimental Setup	70

4.2	The PWM Switching Schemes Experiment	72
4.3	Experimenting BLDC Motor with PWM	77
4.4	BLDC Motor Drives Performance Analysis	80
4.4.1	Switching Loss Effects	83
4.4.2	Harmonic Effects	85
4.4.2.1	Voltage Harmonic	85
4.4.2.2	Current Harmonic	87
4.5	Speed Measurement Using the Human Machine Interface	88
4.6	Discussions	89
4.7	Summary	90

CHAPTER FIVE : CONCLUSIONS

5.0	Introduction	91
5.1	Conclusions	91
5.2	Future Works	92

REFERENCES	94
-------------------	----

APPENDICES

Appendix A– IRF 840 Datasheets
Appendix B – IR2101 Datasheets
Appendix C – UF4001 Datasheets
Appendix D – dsPIC 30F4011 Datasheets
Appendix E – BLDC Datasheets
Appendix F – Microcontroller Programming Code
Appendix G – HMI Programming Code
Appendix H – The Harmonic Voltage Component of the PWM Switching Scheme
Appendix I – The Harmonic Current Component of the PWM Switching Scheme
Appendix J – Speed Profile Data

LIST OF TABLES

	Page
2.1 Comparison of the controllable switch	26
3.1 IRF840 N-Channel Power MOSFET specifications	48
3.2 IR2101 High and low-side driver product summary	50
3.3 <i>Pololu</i> device specifications	65
3.4 BLDC motor specifications	66
4.1 Measurement devices and equipment used in experiment	72
4.2 The BLDC motor performance using the drives system	82
4.3 Converter Technical Specification Summary	90

LIST OF FIGURES

	Page	
2.1	Full bridge 3-phase inverter	8
2.2	Transistors gate conduction for the power devices	9
2.3	Equation for each modes and equivalent circuit for Wye-connected resistive load	10
2.4	Output voltage of the 3-phase inverter.	
	a) Line-to-line voltage	11
	b) Phase voltage	11
2.5	Gate signal and 3-phase output waveform	
	a) Gate signal	12
	b) Phase and line-to-line voltage waveform	12
2.6	3-phase BLDC drives	19
2.7	PWM switching schemes	
	a) Single PWM with 180° pulse conduction angle	21
	b) Single PWM with 120° pulse conduction angle	21
	c) Multiple PWM with 6-pulse per half-cycle	22
	d) Multiple PWM with 4-pulse per half-cycle	22
	e) Sinusoidal PWM	22
	f) Modified Sinusoidal PWM	22
2.8	Characteristics and symbols of the power devices	
	a) N-Channel MOSFET	23
	b) IGBT symbol	23
	c) GTO symbol	24
2.9	MOSFET and IGBT turn-off behavior	27
2.10	Gate driver circuit configuration	
	a) Single-ended gate drive transformer	29
	b) Double-ended gate drive transformer	29
	c) High voltage bootstraps driver IC	29
	d) Floating bias gate drive circuit	30
2.11	Conventional BLDC motor	35
2.12	Three-phase BEMF of BLDC Motors	36
2.13	Three-phase BEMF of PMSM	36
2.14	The BLDC motor circuit modeling	37
2.15	Dynamic per-phase equivalent circuit of BLDC motor	38
2.16	Steady state per-phase equivalent circuit of BLDC motors	39

3.1	System block diagram	46
3.2	3-phase full bridge inverter topology	47
3.3	IRF 840 N-Channel MOSFET	48
3.4	3-Phase MOSFET Bridge Inverter Schematic	49
3.5	Driver IC and typical connection of IR2101	
	a) IR2101 gate driver	50
	b) Typical connection	50
3.6	IR2101 Bootstraps configuration schematic per-phase	53
3.7	Top view of 3-phase power MOSFET cooling system	54
3.8	3-phase inverter switching topology	56
3.9	Flow chart of the dsPIC microcontroller programming algorithm	
	a) Main programming	58
	b) Subroutine for Timer2 Interrupt	59
	c) Subroutine for Input Capture interrupt	59
3.10	The HMI for the system application	60
3.11	Flow chart of the HMI programming algorithm	61
3.12	The microcontroller application circuit	64
3.13	Speed-torque curve of BLDC motor	67
3.14	Power-torque and current-torque curves of BLDC motor	67
4.1	Experimental system set up block diagram	71
4.2	Generated PWM switching schemes using the microcontroller	
	a) Single PWM with pulse conduction angle, $\beta=180^\circ$	73
	b) Single PWM with pulse conduction angle, $\beta=120^\circ$	74
	c) Single PWM with pulse conduction angle, $\beta=175^\circ$	74
	d) Multiple PWM with 6 per half cycle and pulse conduction angle, $\alpha=15^\circ$	74
	e) Multiple PWM with 4 pulses per half-cycle and pulse conduction angle, $\alpha=15^\circ$	75
	f) Sinusoidal PWM with pulse conduction angle, $\alpha=15^\circ$, $\delta=20^\circ$ and $\beta=120^\circ$	75
	g) Modified SPWM with pulse conduction angle $\alpha=15^\circ$ and $\beta=60^\circ$ [14]	75
	h) Modified SPWM with pulse conduction angle $\alpha=30^\circ$ and $\beta=60^\circ$	76
	i) Modified SPWM with pulse conduction angle $\alpha=15^\circ$ and $\beta=90^\circ$	76
	j) Modified SPWM with pulse conduction angle $\alpha=15^\circ$ and $\beta=60^\circ$	76
4.3	Three phase inverter output voltage by Single PWM with 180° conduction angle	78
4.4	Steady-state performance of the BLDC motor terminal voltage and current	
	a) 4.5V voltage supply, 20Hz frequency and speed of 246 RPM	79

	b) 16.6V voltage supply, 100Hz frequency and speed of 1201 RPM	79
	c) 23.7 voltage supply, 190Hz frequency and speed of 2282 RPM	79
4.5	The steady-state BLDC drives characteristics by Single PWM with 180° conduction angle switching scheme	
	a) The motor voltage and current – speed curves	81
	b) The current – electromagnetic torque curves	81
4.6	Comparison of calculated BEMF and measured Vrms of BLDC motor	83
4.7	The percentages of the switching losses	83
4.8	THD percentages of current and voltage	84
4.9	BLDC motor voltage harmonic spectrums	
	a) 4.5V voltage supply, 20Hz frequency	85
	b) 16.6V voltage supply, 100Hz frequency	86
	c) 23.7 voltage supply, 190Hz frequency	86
4.10	BLDC motor current harmonic spectrums	
	a) 4.5V voltage supply, 20Hz frequency	87
	b) 16.6V voltage supply, 100Hz frequency	88
	c) 23.7 voltage supply, 190Hz frequency	88
4.11	Comparison of speed measurement by tachometer and obtained through HMI	89

LIST OF PLATES

	Page
3.1 The developed inverter circuit	
a) Controller circuit for the MOSFET gate driver	55
b) Inverter circuit for BLDC driver	55
3.2 The Brushless DC (BLDC) Motor	66
4.1 The experimental system set up	71

LIST OF SYMBOLS

%	Percentage
μ	Micro
A	Ampere
cm	Centimeter
Cos	Cosinus
E	BEMF Amplitude
H	Henry
Hp	Horse Power
Hz	Hertz
K	Constant
Kg	Kilogram
m	Number of phase
N.m	Newton meter
°	Degrees
s	Seconds
Sin	Sinus
V	Volt
W	Watt
α	Alpha
β	Beta
δ	Delta
η	Efficiency
θ	Theta
λ_m	Stator winding flux linkage
Π	Pi
Φ	Permanent magnet flux
Ω	Ohm
ω_e	Electrical Frequency
ω_m	Mechanical speeds of rotor
Ω	$2\pi f$

LIST OF ABBREVIATION

A/D	Analog/Digital
AC	Alternating Current
ADC	Analog-Digital Converter
B	Damping Constant
BASIC	Beginner's All-purpose Symbolic Instruction Code
BEMF	Back-Electromotive Force
BLDC	Brushless DC
C	Capacitance
C_{BS}	Bootstraps Capacitor
CPU	Control Processing Unit
CSI	Current Source Inverter
D	Duty cycle
D_{BS}	Bootstraps Diode
DC	Direct Current
DF	Distortion Factor
DSC	Digital Signal Controller
DSP	Digital Signal Processor
e_a	Phase BEMF voltage A
e_b	Phase BEMF voltage B
e_c	Phase BEMF voltage C
f_e	Electrical Frequency in Hz
FIFO	First In First Out
f_{osc}	Oscillation Frequency
FPGA	Field Programmable Logic Array
f_s	Switching Frequency
GTO	Gate Turn Off thyristor
GUI	Graphical User Interface
HF	Harmonic Factor
HMI	Human Machine Interface
I	Current
i_a	Phase Current A
i_b	Phase Current B
i_c	Phase Current C
I/O	Input/Output
IC	Integrated Circuit
$I_{cbs(leak)}$	Bootstraps Capacitor Leak Current
ICSP	In-Circuit Serial Programmer
IDE	Integrated Development Environment
I_F	Rectified Forward Current
IGBT	Insulated Gate Bipolar Transistor
I_o	Conducting Current

$I_{qbs(max)}$	Maximum V_{BS} Quiescent Current
J	Moment of inertia
K_v	Voltage gain
L	Inductance
LOH	Lowest Order Harmonic
LPF	Low Pas Filter
M	Magnitude Control Ratio
MCU	Microcontroller Unit
MOSFET	Metal-Oxide-Semiconductor Field Effect Transistor
NEMA	National Electrical Manufacturers Association
p	Number of rotor poles
PC	Personal Computer
P_{cu}	Copper Loss
P_{em}	Electromagnetic Power
P_i	Output Power
PIC	Programmable Interface Controller/Programmable Intelligent Computer
P_{in}	Input Power
PMAC	Permanent Magnet AC
PM	Permanent Magnet
P_{mec}	Mechanical Loss
PMSM	Permanent Magnet Synchronous Machines
P_o	Output Power
P_{on}	ON-state Power Dissipation
PR	Period Register
P_{sw}	Power Dissipation
PWM	Pulse Width Modulation
Q	Transistor
Q_g	Gate Charge
Q_{ls}	Level Shift Charge
R	Resistance
R_{DS}	Drain-Source Resistance
R_{eq}	Equivalent Resistance
RF	Radio Frequency
RMS	Root Means Square
RPM	Revolution per Minutes
SCR	Silicon-Controlled Rectifier
t	Time in seconds
T_e	Electromagnetic Torque
THD	Total Harmonic Distortion
THD_i	Current THD
THD_v	Voltage THD
T_L	Load Torque
T_{losses}	Losses Torque

t_{off}	Off-time
t_{on}	On-time
t_{rr}	Reverse Recovery Time
T_s	Switching Time
UART	Universal Asynchronous Receiver Transmitter
UPS	Uninterruptible Power Supply
USB	Universal Serial Bus
V_1	Fundamental RMS voltage
V_{ab}	Line voltage between phase A and B
v_{an}	Voltage for phase A
V_{average}	Average Voltage
V_{bc}	Line Voltage between phase B and C
v_{bn}	Voltage for phase B
V_{BS}	Bootstraps voltage
V_{ca}	Line voltage between phase C and A
V_{cc}	Logic section voltage
v_{cn}	Voltage for phase C
V_d	Input voltage across switch
V_f	Forward voltage drop across bootstraps diode
V_L	Line voltage
$V_{\text{LL},1,\text{P}(\text{max})}$	Maximum peak value of fundamental line-to-line voltage
V_{LS}	Voltage drop across the low-side FET
V_{min}	Minimum voltage
V_n	Harmonic component RMS voltage
V_p	Phase voltage
V_{RRM}	Power Rail voltage
V_s	Source voltage
VSI	Voltage Source Inverter

LIST OF PUBLICATIONS & SEMINARS

- 1 Norkharziana, M.N, Syafrudin, M., Muhammad Nasiruddin, M., (2009) “A Simplified Design Of A 3-Phase Inverter: An Approach Of Using The Microcontroller To Drive The Brushless DC Motor”. *2nd International Conference on Control Instrumentation and Mechatronics Engineering (CIM 2009)*, 2-3 June 2009, Malacca, Malaysia. pp 510-516.
- 2 Norkharziana, M.N, Syafrudin, M., Muhammad Nasiruddin, M (2008) “Application of Digital Signal Controller to Study the Effects of Brushless DC Motor Performances Using Various Types of PWM Switching Schemes”. *2nd International Conference on Control Instrumentation and Mechatronics Engineering (CIM 2009)*, 2-3 June 2009, Malacca, Malaysia. pp 502-509.
- 3 Norkharziana, M.N, Syafrudin, M., Muhammad Nasiruddin, M., (2008) “Application of Digital Signal Controller (DSC) for Controlling Brushless DC Motor Drives System”. *2nd International Conference on Science and Technology (ICSTIE 2008)- Application in Industry and Education*, Dec. 12-13, Penang, Malaysia. pp 924-928.
- 4 Norkharziana, M.N, Syafrudin, M., Muhammad Nasiruddin, M., (2007) “Design of a Converter for Brushless DC (BLDC) Motor Drives based on Microcontroller”. *International Conference on Robotics, Vision, Information and Signal Processing (ROVISP 2007)*, Nov. 28-30, Penang, Malaysia.
- 5 101 SMR 16-bit Microcontroller Seminar, Organized by Microchip Technology Regional Training Center, 12th July 2007

REKABENTUK PENUKAR BERASASKAN MIKROPENGAWAL UNTUK PEMACU MOTOR ARUS TERUS TANPA BERUS 3-FASA

ABSTRAK

Dalam aplikasi industri dan peralatan perubatan, dapat dilihat kepentingan pengawalan peralatan atau mesin dengan memantau proses keluaran dan kawalan masukan daripada komputer. Pada masa kini, kawalan mesin terletak pada selongsong peralatan dan ianya memerlukan kawalan dan pemerhatian daripada pengendali dari semasa ke semasa. Dengan menggunakan kriteria yang terdapat pada pengawalmikro, operasi dan pemantauan jarak jauh kawalan proses boleh dilakukan. Dalam masa yang sama, pengendali boleh memantau prestasi peralatan dengan hanya menggunakan komputer. Tambahan lagi, penggunaan sistem pemacu ini sangat berguna jika kawalan proses mengandungi bahan material yang berbahaya. Satu rekabentuk penukar berasaskan mikropengawal untuk motor arus terus tanpa berus (BLDC) 3-fasa telah dicadangkan dalam penyelidikan ini untuk memberikan penyelesaian yang lebih baik kepada kawalan jarak jauh dan memberikan pilihan bagi sesebuah sistem pemacu motor. Sistem pemacu motor yang direkabentuk mempunyai kelebihan dari segi keperluan perkakasan yang minimum, pelaksanaan sistem berkos rendah dan berupaya melaksanakan variasi pensuisan skim kawalan dedenyut. Rekabentuk sistem juga memberikan ketepatan kawalan halaju dan sambutan yang baik kepada sistem pemacu. Keluaran dan masukan bagi motor boleh dikawal melalui pemacu motor dan dipantau dengan menggunakan Pengantaraan Manusia Mesin (HMI) berasaskan perisian komputer. Analisis yang lebih mendalam untuk sampel skim pensuisan telah dilaksanakan menggunakan system penukar. Penyelidikan yang dijalankan menunjukkan skim pensuisan yang dipilih boleh digunakan untuk memacu motor arus terus tanpa berus (BLDC) 3-fasa, di samping itu pelarasan kelajuan juga dapat dilakukan dengan mudah. Hasil ujikaji yang diperolehi menunjukkan kesan ke atas prestasi motor arus terus tanpa berus (BLDC) apabila dipacu oleh sampel skim pensuisan PWM.

DESIGN OF A MICROCONTROLLER-BASED CONVERTER FOR 3-PHASE BRUSHLESS DC MOTOR DRIVES

ABSTRACT

In industrial application and medical devices, it can be seen that there is a need of controlling the devices or machines with observation of the output process and input control from a computer. Presently, machines control is located on the devices casing as it may require control and observation from the operator from time to time. By utilizing the features of microcontroller, operation and monitoring the process control can be done far away from the operating equipment. In the mean time, operator can observe the performance of the equipment by just using the computer. Furthermore, if the process control contains hazardous material, a long distant controller may be useful for the application of this drive system. The microcontroller-based converter system design for 3-phase BLDC motor drives has been proposed in this research in order to create better solution for long distance control and provides another selection of motor drives system. The designed motor drives system has the advantages of minimum hardware requirement, low-cost system implementation and capable of performing variant pulse control switching schemes. The designed system also provides speed controls accuracy and good response to the drive system. The input and output of the motor can be controlled on the drives and observed by using HMI-based computer software. Further analysis on the sample of PWM switching scheme has been made using the converter system. This research has shown that the selected switching scheme can be used to drive the 3-phase BLDC motor while the speed adjustment can be easily made. The experimental results obtained describe the effects of the 3-phase BLDC motor performance when driven with a sample of PWM switching scheme.

CHAPTER 1

INTRODUCTION

1.0 Introduction

Power Electric motor technology involves machine constructions, materials, electronics, sensors and control technologies and they are all developing rapidly. It can be seen that there is a need of developing a suitable converter and control techniques for different kind of motors in order to produce a high performance motors. The benchmark of the converter efficiency is by measuring the power converter performances; as high efficiency will lead to low power loss converters [1]. One of the main reasons of using three-phase power system for DC drives system is that the 3rd harmonic and its corresponding multiples component are cancelled out in the output [2]. Comparing one-phase system with that of 3-phase, the ripple voltage is significantly less.

The interest of using microcontroller in this research as the controller came from the capability of the microcontroller to produce proper design of the control signal with flexibility. The importance of the proper design of control signals with powerful switching is to reduce the harmonics and power losses of the inverter output voltage. The potential of the microcontroller to carry out the mathematical and logical functions allows it to imitate logic and electronics circuit. The main characteristic of the MOSFET such as faster switching speed and the ability of producing high switching frequency have fulfilled the need of the power switches of the converter. This approach has been used to replace the existing analogue controller. The usage of digital controller improves the system performances including its accuracy, low-cost system, low power dissipation and longer life of operation.

“Electronic power converter” is a term that is used to refer to the power electronic circuit that converts the voltage and current from one form to another. This converter can be classified as:

- i. Rectifier – Converting an AC voltage/current to a DC voltage/current.
- ii. Inverter – Converting a DC voltage/current to an AC voltage/current.
- iii. Chopper/Switch Mode Power Supply (SMPS) – Converts a DC voltage/current to another level of DC voltage/current.
- iv. Cycloconverter/Cycloinverter – converts an AC voltage/current to another level of AC voltage/current.

An inverter is used in order to supply an AC voltage needed to operate a Brushless DC (BLDC) motor. However, the BLDC motors just require a rectangular current waveform to produce a constant torque operation.

A BLDC motor is a DC electric motor that uses an electronically-controlled commutation system, instead of a mechanical commutation system. BLDC motor can potentially be deployed in any field application that currently fulfilled by brushed motors. Unfortunately, the BLDC motor cost is expensive and this is not favoured by users to replace the brushed motors in most common area. However, BLDC motor has come to dominate many applications; home appliances and office and laboratory medical equipment and also food and chemical processing industries. BLDC motor also can be found in small package applications which featuring efficient and economical rotation for valve control mechanisms, miniature pump, surveillance cameras, compact cooling devices, scanners, small centrifuges and variety of platter-spin applications. Low speed, low power BLDC motor are used in direct drives turntables, medical devices such as rotary evaporators, bottle rollers and shakers, liquid mixers and vibrators, and etc . Meanwhile, for a high power BLDC motors are found in electric vehicles, and some industrial processing machinery such as mixer, conveyor belt, and some other machines that include a rotating motor as part of the operation.

The specialty of BLDC motor which gain more merits over brushed DC motor and induction motor is the main concern of choosing motor as an application. One of the main

advantages of these types of motor configuration is the exclusion of the brushes, which eliminates brush maintenance and sparking associated with them. From the aspect of the motor architecture, having the armature windings on the stator helps the conduction of heat from the winding, which results in minimization of electrical losses in the rotor. BLDC motor features better speed versus torque characteristics, higher speed range achieved, noiseless operation with high efficiency and greater longevity [3]. Field excitation of BLDC motor is fixed and the torque produced is proportional to the armature current. Therefore BLDC motors are ideally suited for constant – torque applications. The selected BLDC motor to be driven by the converter system has 3 phase configurations. The stator has same number of winding corresponding to its configuration type. Therefore, BLDC motor is chosen as the application of the inverter system because of the characteristic of the BLDC motor which is excited with a pulse current which requires 3 phase inverter output.

1.1 The Research Aim and Objectives

The aim of this research is mainly to develop a converter system which can be used to drive 3-phase BLDC motor. The main objectives are as follow:

- i. To design a 3-phase microcontroller-based converter, emphasizing on the inverter circuit for driving a 3-phase BLDC motor.
- ii. To implement several PWM switching schemes to generate pulses for the inverter to drive a 3-phase BLDC motor.
- iii. To interface the designed system with a Personal Computer (PC). A Human Machine Interface (HMI) will be developed to provide interactive communication between the user and the systems for output observation and performance analysis purposes.
- iv. To observe the BLDC output performance using the HMI and analyze the performance parameter of BLDC motor such as the motor voltage, current, speed, and developed torque.

1.2 Problem Statements

Power converter in the BLDC motor drives system consists of two parts, which is a rectifier and 3-phase full bridge inverter. Control schemes for this motor drives typically a PWM waveform driving the inverter. A suitable switching technique is needed to generate pulses to drive the power device circuit. To produce the desired output, PWM switching technique will be used to generate the pulses for power device via microcontroller. The pulses must be precisely determined and synchronized for each switching and phase sequence with the intention of avoiding glitches, delay or shoot-through phenomena during the course of switching process. Factors to be considered in designing the converter for the BLDC motor drives in order to meet the requirement includes a suitable switching technique and controlling switching angles for the BLDC motor rotation and controllable magnitude and frequency of the output voltage.

In industrial application (such as food and chemical processing) and medical devices (especially in laboratory application equipment), it can be seen that there is a need of observing the device or machine output processes. Currently, machines control is located on the devices casing as it may require control and observation from the operator from time to time. By utilizing the features of microcontroller, serial communication between the equipment and computer can be done. Operation and monitoring the process control can be done far away from the operating equipment. In the mean time, operator can observe the performance of the equipment through the computer HMI and control it according to the output demand. Furthermore, if the process control contains hazardous material, a long distant controller may be useful for the application of this drives system.

Therefore, the main idea of this project is to design a microcontroller-based converter for BLDC motor drives. The system is used to observe the BLDC motor performance parameter from a personal computer through the HMI. The performance of the converter parameter will be tested and observed based-on several PWM switching schemes.

1.3 Project Contributions

BLDC motors are one of the motor types that rapidly gaining popularity and it is gradually replacing brushes DC and AC motor [4]. The BLDC motors have a wide range of application. It can be seen in industrial application such as in food processing and chemical process, air-craft design and modelling, medical instruments and home appliances. Most of the high power equipment applications required Human Machine Interface (HMI) application between the operator and the machines which will ease the operation of the process control. Process control that requires output observation frequently may save time of the operator if all the control input and observation of the output process are supervised in the same control panel. The controller's control panel for machines application especially in medical laboratory equipment, that involve rotational system such as rotary evaporator, stirrer, rollers and shaker in laboratory can be developed using the proposed system to facilitate industrial, educational and research operations. The same thing goes to the industrial machines application, whereby implementation of this system can save cost and time of the machines operator. A safe working environment for operation of hazardous material process control also can be build. This research will contribute to this field of application as the system can be integrated into industrial and laboratory equipment, involving the control of rotational machines at a remote distance.

1.4 Structure of Thesis

This thesis is organized into five chapters as following.

Chapter 2 discusses the literature survey on the theories of the 3-phase converter for 3-phase BLDC motor operation including the switching techniques and power devices operation. This chapter revisits the conventional methods to generate control signals as well as providing the overview of the microcontroller. Comparison of the characteristics for power switching devices and motor is also presented. The existing method to generate control

signal through microcontroller and various type of PWM schemes to drive a BLDC motor are also discussed.

Chapter 3 presents the design and development of the inverter circuit including the software design and the control circuit design needed to generate the control signal for the power switches. The PWM switching schemes for BLDC motor will be explained in details in this chapter. Calculation of the switching frequency and the procedure of loading the algorithm into the microcontroller with C programming language are described in this section. The converter circuit was designed and tested in stages before applying as the drives circuit.

Chapter 4 discusses 10-types of PWM schemes and a sample of a PWM scheme for the motor drives was analysed. The drives system and the BLDC motor performance were also presented. The discussion and analysis for each stage is done and concluded.

Chapter 5 outlines the conclusions and future works. This chapter concludes the overall research findings especially on the control circuit output and the applied PWM switching performances.

CHAPTER 2

LITERATURE REVIEW

2.0 Introduction

In this chapter, the basis theories of 3 phase converter and architecture of the BLDC will be reviewed. The switching scheme, power device, programming environment and control technique are described.

2.1 Converter

Converter in power electronics field is an electrical device that converts power from of an electrical signal or power source, by converting it from one form to another. Generally, converter can be classified to 4 categories which is a rectifier, inverter, chopper and cycloconverter. Converters are used for applications such as rectification of AC to DC, or an inversion from DC to a controlled frequency of AC to supply variable speed AC motor, interfacing DC power sources to AC distribution systems such as photoelectric devices and also productions of DC from AC power for subway and for controlled DC voltage for speed control of DC motor in various industrial applications and etc.

2.1.1 Inverter

The function of an inverter is to change a DC input voltage to a AC output voltage of desired frequency and magnitude[5]. In case of 3-phase inverter, the inverter circuit changes a DC input voltage to a symmetrical AC output voltage of desired magnitude and frequency. Output voltage could be fixed or variable at a fixed or variable frequency. Variable output voltages are obtained by varying the input DC voltage with maintaining the gain of the inverter constant. Meanwhile, if the DC input voltage fixed and not controllable, variable output voltage can be obtained by varying the frequency of the inverter which is usually done by implementing PWM control within the inverter. The output voltage of an inverter has a periodic waveform which is not purely sinusoidal, but with number of techniques it can

be designed to closely approximate to this desired waveform. Inverter can be built with any number of output phases. Practically, single-phase and three-phase inverters are most commonly used. It depends on the user requirement whether in the industrial applications, transportations and home appliances. In most circumstances, three-phase inverter offered better performances as compared to single-phase inverter.

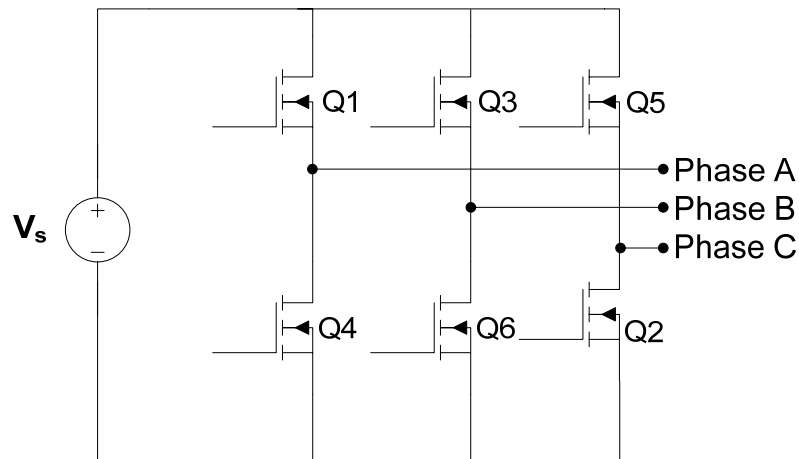

Figure 2.1: Full bridge 3-phase inverter.

Power semiconductor switches are the basic building component of the inverter. Further discussion of power semiconductor will be discussed on section 2.3. Generally there were two types of inverter topology, named as Voltage Source Inverter (VSI) and Current Source Inverter (CSI). Voltage waveform is the independently controlled AC output in the VSI topologies. Meanwhile, in CSI topologies, the independently controlled AC output is a current waveform. VSI can be further divided into three categories which is PWM Inverter, Square Wave Inverter and Single-phase Inverters with Voltage Cancellation[2]. The close-up for 3-phase VSI is shown in Figure 2.1. The structure of VSI is more widely used in the industrial application due to the voltage source requirement.

2.1.2 Three Phase Inverter

Single phase inverter covers low range power applications. Meanwhile, 3-phase inverters are usually used for a high-power application. The 3-phase inverters generally are

used for supplying 3-phase load especially in AC motor drives and uninterruptible AC power supplies. A 3-phase output can be obtained from a configuration of six transistors as shown in Figure 2.1. The transistors are numbered in the sequence of gating transistor (e.g 156, 126, 123, 234, 345, 456) and each of the transistors conducts for 180° . In order to avoid undefined states in the VSI, and undefined AC output line voltages, switches between upper leg and lower leg of the inverter cannot be switched off simultaneously as this will result in voltages that will depend upon respective line current polarity[6]. In addition, it is also would result in a short circuit across the DC link voltage supply which will damage the inverter system if the switches is switching on simultaneously. There are six modes of operating the switches, where in a cycle the phase shift of each mode is 60° . In order to generate a desired voltage waveform, the transistor condition moves from one states to another. The gating signals shown in Figure 2.2 are shifted from each other by 60° to obtain 3-phase balanced (fundamental) voltages as shown in Figure 2.4(a). The load can be connected in wye or delta connection. The line current is determined when the phase current are known. For a wye-connected load, the line to neutral voltages must be determined to find the phase current.

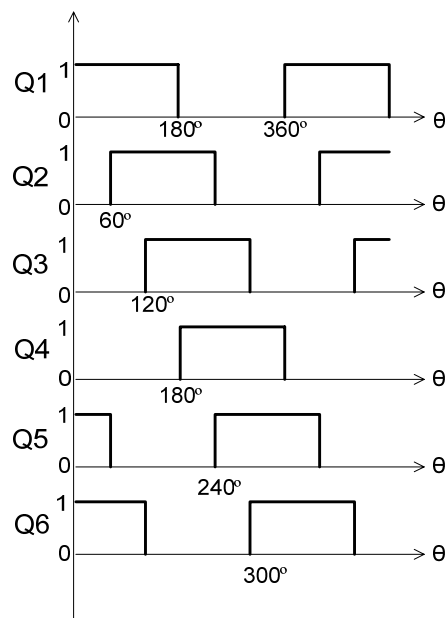

Figure 2.2: Transistors gate conduction for the power devices

3 modes of operation in a half cycles and the equivalent circuits are shown in Figure 2.3. as below,

Mode 1; for $0 \leq \theta < 60^\circ$

$$R_{eq} = R + \frac{R}{2} = \frac{3R}{2}$$

$$i_1 = \frac{V_s}{R_{eq}} = \frac{2V_s}{3R}$$

$$v_{an} = v_{cn} = \frac{i_1 R}{2} = \frac{V_s}{3}$$

$$v_{bn} = -i_1 R = -\frac{2V_s}{3}$$

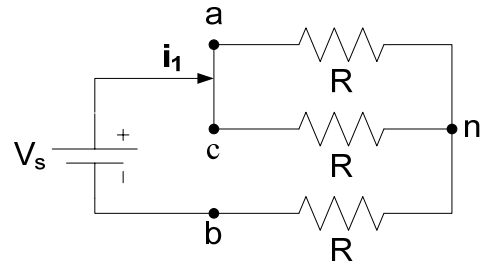

Mode 2; for $60^\circ \leq \theta < 120^\circ$

$$R_{eq} = R + \frac{R}{2} = \frac{3R}{2}$$

$$i_2 = \frac{V_s}{R_{eq}} = \frac{2V_s}{3R}$$

$$v_{an} = i_2 R = \frac{2V_s}{3}$$

$$v_{bn} = v_{cn} = -i_2 R = -\frac{2V_s}{3}$$

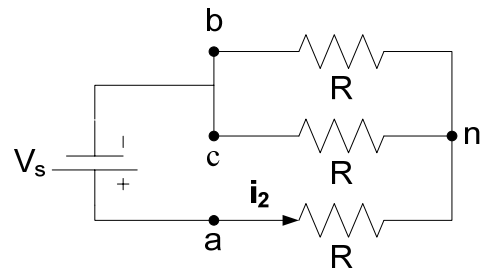

Mode 3; for $120^\circ \leq \theta < 180^\circ$

$$R_{eq} = R + \frac{R}{2} = \frac{3R}{2}$$

$$i_3 = \frac{V_s}{R_{eq}} = \frac{2V_s}{3R}$$

$$v_{an} = v_{bn} = \frac{i_3 R}{2} = \frac{V_s}{3}$$

$$v_{cn} = -i_3 R = -\frac{2V_s}{3}$$

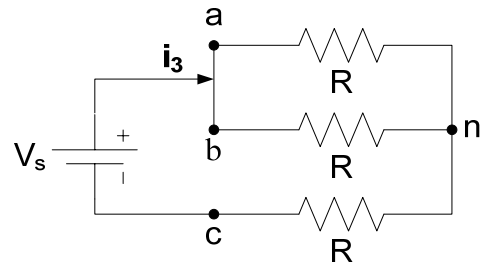

Figure 2.3: Equation for each modes and equivalent circuit for Wye-connected resistive load

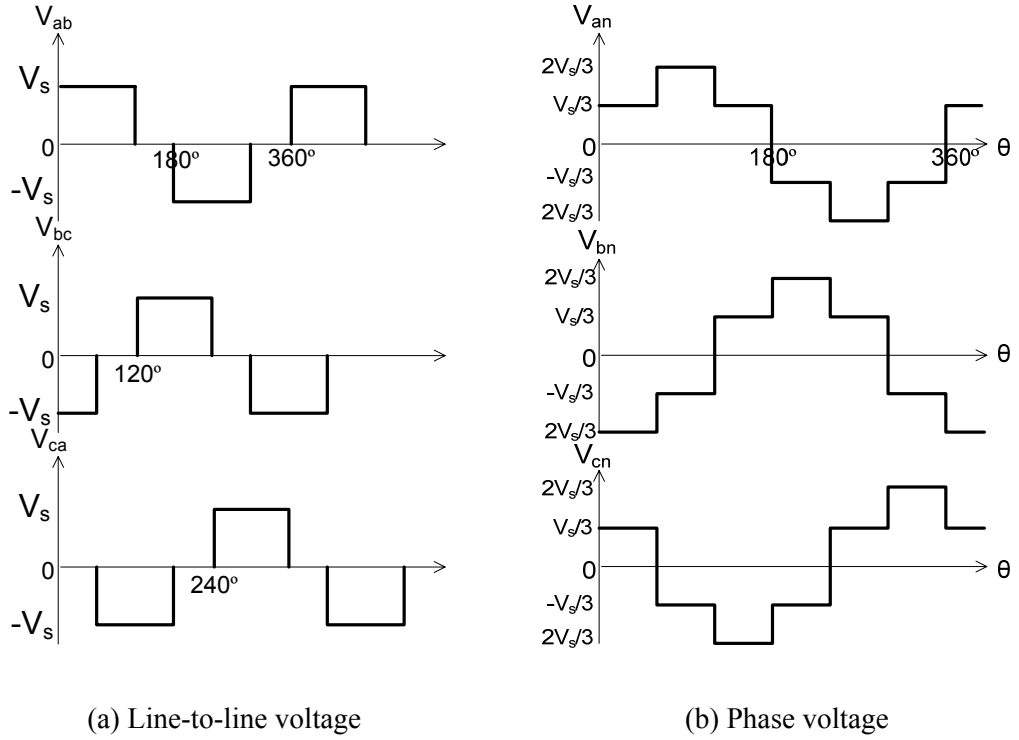

Figure 2.4: Output voltage of the 3-phase inverter

The line-to-neutral voltages are shown in Figure 2.4(a). This scheme shows that line-to-line output voltages are $+V_s$, 0 or $-V_s$. The instantaneous line-to-line voltage v_{ab} can be expressed in a Fourier series as describe in equation below [5]:

$$v_{ab} = \sum_{n=1,3,5}^{\infty} \frac{4V_s}{n\pi} \cos \frac{n\pi}{6} \sin n \left(\omega t + \frac{\pi}{6} \right) \quad (2.1)$$

v_{bc} and v_{ca} are obtained from equation 2.1 by shifting v_{ab} by 120° and 240° ,

$$v_{bc} = \sum_{n=1,3,5}^{\infty} \frac{4V_s}{n\pi} \cos \frac{n\pi}{6} \sin n \left(\omega t - \frac{\pi}{2} \right) \quad (2.2)$$

$$v_{ca} = \sum_{n=1,3,5}^{\infty} \frac{4V_s}{n\pi} \cos \frac{n\pi}{6} \sin n \left(\omega t - \frac{7\pi}{6} \right) \quad (2.3)$$

It is also shown that in equation (2.1), (2.2) and (2.3) the triplens harmonics is zero in the line-to-line voltage. The line-to-line RMS voltage is expressed in equation (2.4), whilst the RMS value of line-to-neutral voltage is in equation (2.5):

$$V_L = \sqrt{\left[\frac{2}{2\pi} \int_0^{2\pi/3} V_s^2 d(\omega t) \right]} = \sqrt{\frac{2}{3}} V_s \quad (2.4)$$

$$V_p = \frac{V_L}{\sqrt{3}} = \frac{\sqrt{2}}{3} V_s \quad (2.5)$$

Meanwhile, there is other type of gate pulse arrangement that can reduce the possibility of shorting-out the DC source [7]. By using the same inverter circuit as in Figure 2.1, the gate current of the switch are applied at 60° interval at the output voltage waveform with each transistor is turned on for a duration 120° in sequence to yield balanced voltage v_{ab} , v_{bc} and v_{ca} . Figure 2.5(a) shows the gate pulses for a practical circuit implementation. An interval 60° elapses between the ends of gate signal applied to Q1 and the beginning of gate signal to Q4, which is in series in Q1. The same characteristics applied to the pairs of Q2 and Q5 as well as Q3 and Q6. In the case for a 3-phase balance resistive load, the phase voltage magnitude across each of the two resistors becomes half from the source voltage as shown in Figure 2.5(b). It can be seen that for 0 to 60° interval, v_{an} equal to $v_s/2$ and v_{bn} value is $-v_s/2$.

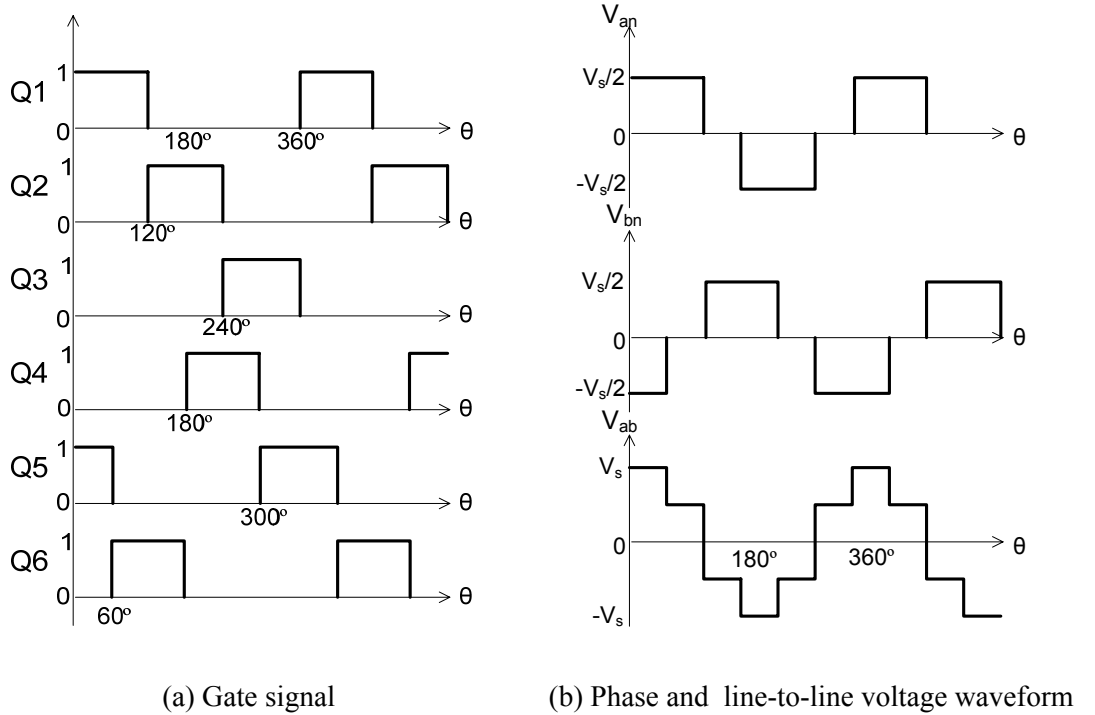

Figure 2.5: Gate signal and 3-phase output waveform.

The phase voltages v_{an} , v_{bn} and the resulting line output voltage v_{ab} are shown in the same figure. The v_{bc} and v_{ca} voltages are obtained in similar methodology.

2.1.3 Voltage and Frequency Control Technique

Application control of output voltage of inverters is necessary to cope with the variation of DC input voltage and to regulate voltage of inverters. Furthermore, it satisfies the constant volts and frequency control requirements. Controlling an inverter output to meet operational requirements can be done by a number of techniques. However, it is all depends on the available hardware and the nature of the DC source. Normally, the inverter output voltage and frequency are controlled continuously. For applications of motor drives, the range of voltage and frequency is wide. The voltage and frequency control requirement depends on the motor load variations. Meanwhile, inverter frequency control is very straightforward. The control command can be generated either from an analogue-digital circuit, microprocessor, microcontroller, digital signal processor or FPGA to supply the gate signal for driving the switches of the converter. Generally, inverter output voltage is controlled by inverter's supply voltage or by the PWM voltage control.

Common desirable arrangement permits varying the ratio of the DC input voltage and the AC output voltage using PWM. The quality of the inverter operation can be improved by implementing the PWM which deals with the control schemes. The implementation of multiple switching within the inverter makes it possible to control and optimize the harmonic content of output voltages. There are many kind of PWM technique available for a 3-phase inverter. Further explanation on PWM is discussed on section 2.2. The VSI have been used widely for low and medium rating of motor drives. The controlled variables are the amplitude and frequency of the fundamental output voltage in VSI. The PWM schemes for VSI are used for either the output voltage or output current control. Classification of the PWM schemes broadly on the basis of voltage control or current control techniques makes it becomes the control schemes for the VSI.

2.1.4 Performance Parameter of an Inverter

In order to measure the quality of the output of an inverter, the following performance parameter is commonly used[5, 8].

- i. Harmonic factor, HF: A measure of individual harmonic contribution. The harmonic factor (at the n^{th} harmonic) is defined as,

$$HF_n = \frac{V_n}{V_1} \quad (2.6)$$

Where V_1 is the RMS value of the fundamental component and V_n is the RMS value of the n^{th} harmonic component.

- ii. Total harmonic distortion, THD: A measure of closeness in shape between a waveform and its fundamental component.

$$THD = \frac{1}{V_1} \sqrt{\sum_{n=2,3,\dots}^{\infty} V_n^2} \quad (2.7)$$

- iii. Distortion factor, DF: A measure of effectiveness in reducing unwanted harmonics without having to specify the values of a second-order load filter. It indicates the amounts of harmonic distortion that remains in a particular waveform after the harmonics of that waveform have been subjected to second-order attenuation.

$$DF = \frac{1}{V_1} \sqrt{\sum_{n=2,3,\dots}^{\infty} \left(\frac{V_n}{n_2}\right)^2} \quad (2.8)$$

DF of an individual (or n^{th}) harmonic component defined as,

$$DF_n = \frac{V_n}{V_1 n^2} \quad (2.9)$$

- iv. Lowest-order harmonic, LOH: The lowest-order harmonic is the harmonic component whose frequency is closest to the fundamental one, and its amplitude is greater than or equal to 3% of the fundamental component.

- v. Power efficiency, η ,

$$\eta = \frac{P_o}{P_i} \quad (2.10)$$

Whereas P_i and P_o denotes the input power and output power of the converter, respectively.

2.1.5 Filter

Filter is widely used in power electronics to reduce harmonic components at the output waveform. It is also used for smoothing the voltage wave of a load fed from a rectifier in reducing the harmonic content of an inverter output , preventing unwanted harmonic component being reflected into AC system and eliminating RF interference[9]. Output of the inverter is a “chopped DC voltage with zero DC components”. In certain types of application, “high purity” sine wave output is required such as UPS. For this purpose, an LC section low-pass filter is normally fitted at the inverter output to reduce the high frequency harmonics. Nevertheless, in some applications such as AC motor drives, filtering is not required. Besides, with PWM switching schemes algorithm, elimination of certain harmonic can be done without using external filter circuit on the converter system.

2.2 Pulse Width Modulation (PWM)

PWM is one of the switching techniques widely used in controlling the output of the inverter especially in overcoming the harmonics problem. It is known that PWM method can moved the unwanted frequency component to a higher frequency region. Conventional method of generating PWM signal is by using a high ratio of carrier frequency signal and fundamental frequency signal generated via analogue circuit. Advancement in the digital technology enables PWM switching schemes to be generated using digital controller (i.e. microcontroller). Through this technique, the harmonics content of the output voltage can be minimized and reduced significantly by simply adjusting the switching angles of the pulses

using the programming language. Besides, generating PWM using digital controller ensure the signal remains digital all the way from the processor to the control system.

The Pulse Width Modulation (PWM) switching schemes has become the essence of adjusting speed in motor drives system. These switching schemes can vary the magnitude of the voltage across the terminals of the loads and speed of the rotor shaft. It is also known that, the unwanted frequency component can be moved to a higher frequency region by means of several PWM switching schemes. With the used of digital controller, the circuitry for PWM switching generation can be simplified and the cost of the motor drives can be reduced. There have been various research carried out related to PWM switching schemes. These include digital implementation, minimization of switching losses, harmonic current and THDs, extension of linear modulation range and also reduction of calculation complexity [5, 10].

Generally, there are two types of PWM modes operation namely PWM voltage mode and PWM current mode. PWM voltage mode derives its control signal from the output voltage of the switching converter. Meanwhile PWM current mode utilizes both the output voltage information as well as current information from the inductor in the switching converter to determine the desired duty cycle applied to the switching transistor. The implementation for PWM current mode is quite difficult compared with the PWM voltage mode. The ideal PWM switching strategy for power electronics converter is the one that can achieve the maximum possible voltage or current transfer ratio for a given converter, whilst generating minimum low-order harmonic and creating minimum switching losses.

Listed below is the list of PWM techniques currently being used for industrial application and home appliances for power converter;

- i. Single PWM
- ii. Multiple PWM

- iii. Sinusoidal PWM
- iv. Modified Sinusoidal PWM
- v. Sinusoidal PWM with unipolar voltage switching
- vi. Sinusoidal PWM with bipolar voltage switching
- vii. Phase displacement control
- viii. Harmonic Elimination PWM
- ix. Vector PWM
- x. Hysterisys PWM

2.2.1 Types of PWM

In general, PWM can be classified in the following categories [7]:

- i. Single-pulse modulation
- ii. Multiple-pulse modulation
- iii. Sinusoidal-pulse modulation

These types of PWM are the most common PWM type that mostly discussed. The switching schemes are used for the gating signal of the Voltage Source Inverter (VSI) which is commonly used to drive the BLDC motor [5]. Using the PWM switching scheme, several parameter can be adjusted to generate the desired voltage and frequency to the load.

Experimental comparison of two PWM strategies which is the Vector-Selection PWM and the Average voltage PWM have been discussed by Matsui and Ohashi [11]. These PWM strategies result in the reduction of acoustic noise in the system. The paper also discussed the usage of digital signal processor instead of Digital Signal Controller (DSC) which is the microcontroller presented in this research. Besides, there was also another method with other types of PWM that can be used in an inverter system as presented in [12] which will increase the fundamental output component by 15 percent as compared to conventional sinusoidal inverter.

PWM switching strategy mostly concentrates on reducing power loss, total harmonics distortion and increasing the efficiency of the inverter. Two types of PWM waveforms that have been used in industry describe in [13] are square and sinusoidal waveform. PWM is a way for digitally encoding analogue signal levels. Through the use of high-resolution counters, the duty cycle and switching angle of a square wave is modulated to encode a specific analogue signal level. Given a sufficient bandwidth, any analogue value can be encoded with PWM. On the other hand, PWM is also used for varying the duty cycle, which can be defined as,

$$\text{Duty cycle, } D = \frac{t_{on}}{t_{on} + t_{off}} \quad (2.11)$$

Where, D can be varied by modulating either t_{off} , t_{on} or both.

The desired characteristic of a PWM technique includes:

- i. Good utilization of the DC supply voltage which is a possible high value of the voltage gain, K_v , defined as:

$$K_v = \frac{V_{LL,1,P(\max)}}{V_s} \quad (2.12)$$

Where $V_{LL,1,P(\max)}$ denotes the maximum peak value of the fundamental line-to-line output voltage available using the technique and V_s is the bus voltage.

- ii. Linearity of the voltage control, that is,

$$V_{LL,1,P}(M) = MV_{LL,1,P(\max)} \quad (2.13)$$

Where M denotes the magnitudes control ratio which defines as the ratio of the actual output voltage to the maximum available value of this voltage, either line-to-line, line-to-neutral or RMS value of the voltage.

- iii. Low amplitude of low-order harmonics of output voltage. It is harmonic content minimization of the output current.
- iv. Low switching losses in the inverter switches.
- v. Sufficient time allowance for proper operation of the inverter switches and control system.

Figure 2.6 shows the block diagram for a 3-phase BLDC drives, which consists of a 3-phase inverter and a BLDC motor. The 3-phase inverter uses a signal generated by the microcontroller to trigger the power device to produce necessary current in the motor winding for rotor shaft rotation. The conduction period of the upper leg and lower leg of the power devices must not in the same time to avoid shoot-through phenomenon. In addition, the transition of the ON and OFF time between it must be as short as possible to avoid switching loss of the power devices.

The inverter is controlled by PWM switching schemes to drive the BLDC motor. The conduction of the signal sequences for every gate of the MOSFET for a practical inverter circuit implementation has been discussed and shown in Figure 2.2. The gating signals are shifted by 60° by each gate to obtain a 3-phase balanced fundamental voltage with 120° phase shift. The setting of the conduction period is done by programming the desired on time of the MOSFET onto the microcontroller.

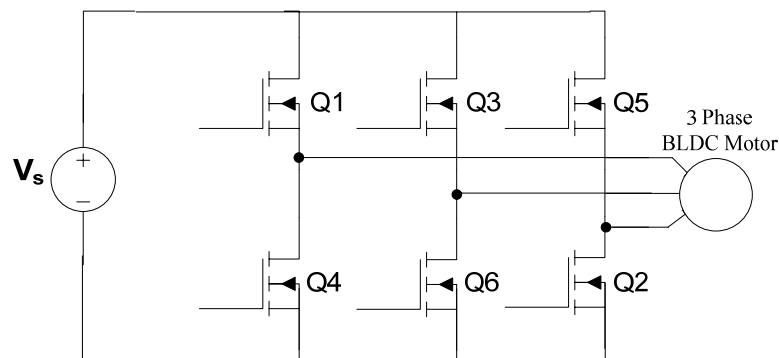

Figure 2.6: 3-phase BLDC drives

Previous researchers show that, there were many switching schemes that can be applied to the inverter to drive BLDC motor such as the Novel Loss Reduction PWM technique [14, 15], Novel Digital Control technique [15] and Sliding Mode Current Control scheme [16]. In this research, there are four types of PWM switching schemes that have been

applied. The schemes are Single PWM, Multiple PWM, Sinusoidal PWM and Modified-Sinusoidal PWM as shown in Figure 2.7.

2.2.1.1 Single PWM

In single-pulse-width-modulation control, there is only one pulse per half-cycle and the frequency of the pulse is varied to control the speed of the motor. The undesired lower order harmonics can be eliminated using this switching scheme. Figure 2.7(a) and 2.7(b) shows the PWM switching schemes for the inverter. The techniques consist of varying the switching frequency of the inverter. This approach is beneficial in eliminating any specified harmonics of the output voltage waveform.

2.2.1.2 Multiple PWM

The general idea of multiple PWM is illustrated on Figure 2.7(c) and 2.7(d). The harmonic content can be reduced by using several pulses in each half-cycles of the output voltage which is called Multiple PWM or some defined it as Fixed Width Modulation[17]. The generation of gating signal is by dividing Single PWM to a smaller and equilibrium portion of existence pulse. The signal waveforms consist of N pulses each half cycle at specified frequency.

2.2.1.3 Sinusoidal PWM

Sinusoidal PWM as shown in Figure 2.7(e) is one of the switching schemes that utilize large DC signal [18]. It is a very popular switching scheme among the industrial converter applications. Previously, basic principle application of sinusoidal PWM inverter with power MOSFET has been described in [12], whereby the direct supply voltage is utilized effectively and the heating of the device is reduced. Instead of maintaining the width of all pulses the same as in the case of multiple PWM, the width of each pulse is varied in proportion to the amplitude of a sine wave evaluated at the centre of the same

pulse. Sinusoidal PWM switching scheme reduces the distortion factor significantly and eliminates the lower order harmonics.

2.2.1.4 Modified Sinusoidal PWM

Modified Sinusoidal PWM as shown in Figure 2.7(f) is done by modifying single-edge of Sinusoidal PWM. The generated PWM have less number of pulse compared to Sinusoidal PWM. This switching scheme reduces harmonic content and increases the fundamental component. In addition, due to the less of pulse generated, the switching loss also can be reduced.

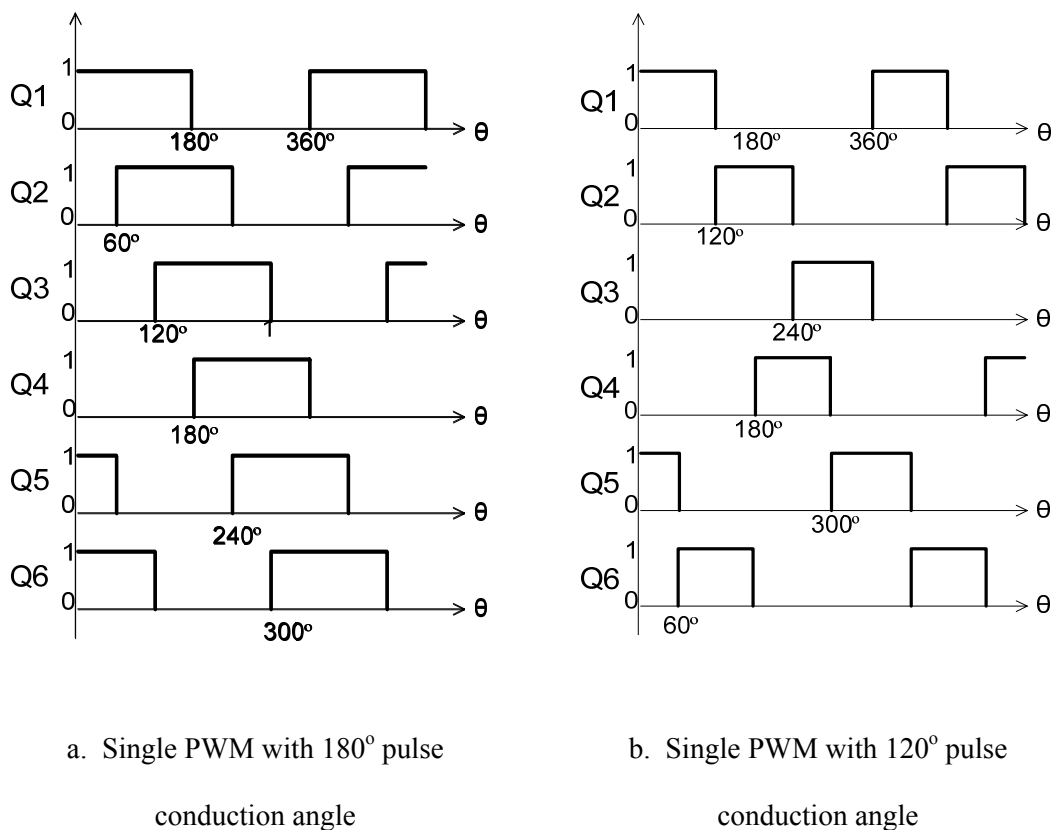
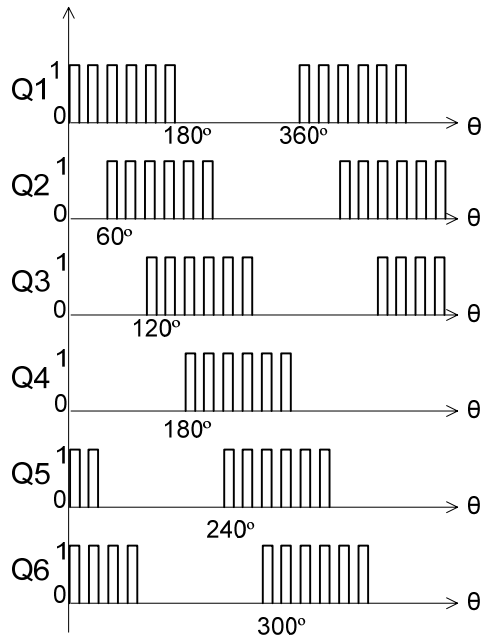
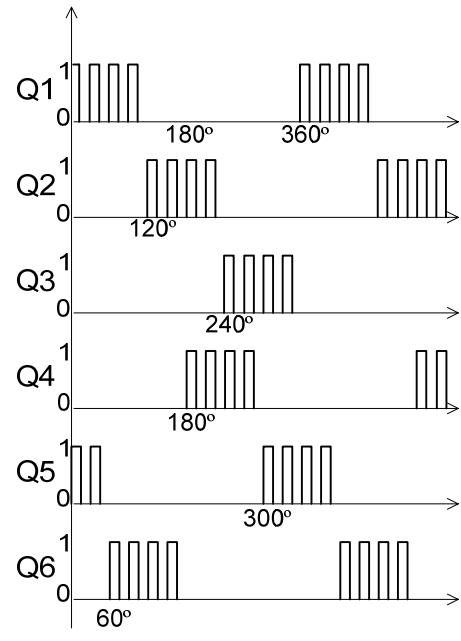

Figure 2.7: PWM switching schemes



c. Multiple PWM with 6-pulse
per half-cycle



d. Multiple PWM with 4-pulse
per half-cycle

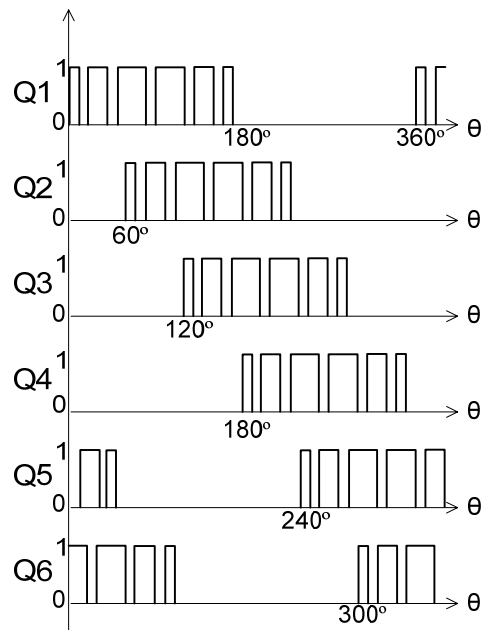

e. Sinusoidal PWM

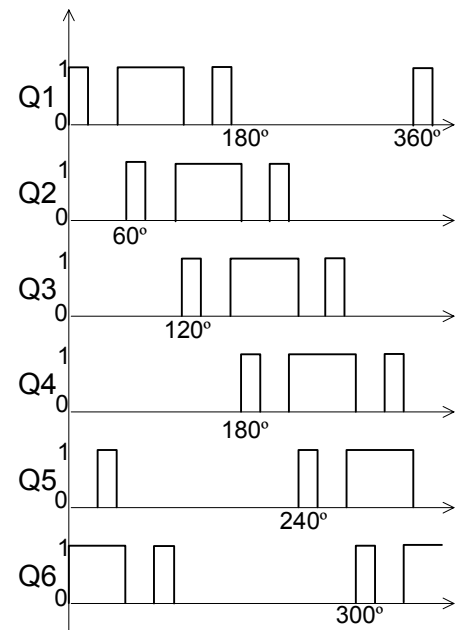

f. Modified Sinusoidal PWM

Figure 2.7: PWM switching schemes

2.3 Power Semiconductor Device

2.3.1 MOSFET, IGBT and GTO

The availability of power semiconductor device with better electrical characteristic influences the improvement in the motor drives performances. Therefore, it is important to choose the suitable power device for the motor drives. Formerly, SCRs were used in high and medium-power inverters [8]. However, in order to turn the SCR off, extra commutating circuit is required. Unfortunately these commutating circuits increase the inverter size and cost. Therefore the reliability and switching frequency of the inverter is degrades. At present, fully controlled semiconductor power switches have outperformed the SCRs. MOSFETs, IGBTs and GTOs are the most widely used power semiconductor switching device. MOSFETs and IGBTs taking part in low and medium-power inverters meanwhile GTOs are involved in high-power inverters.

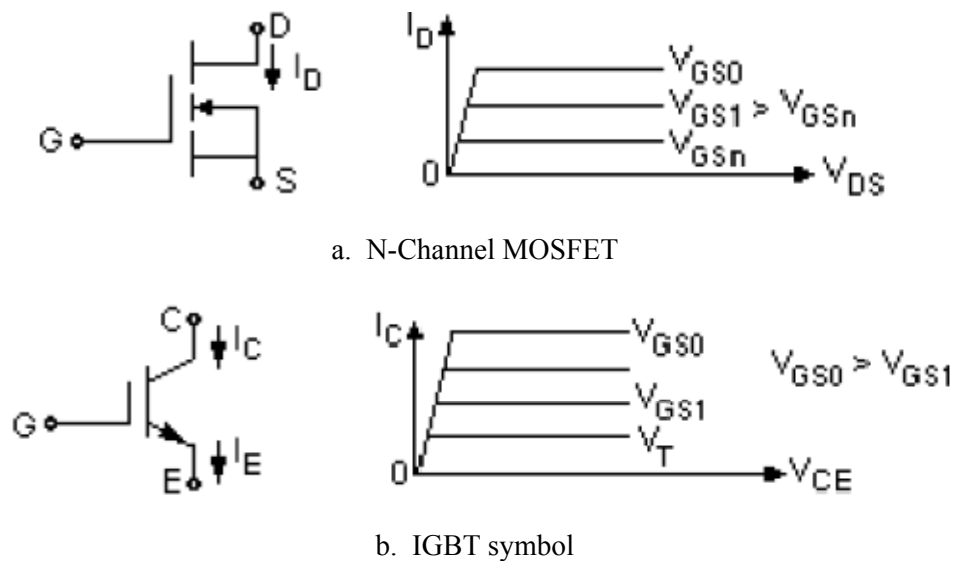
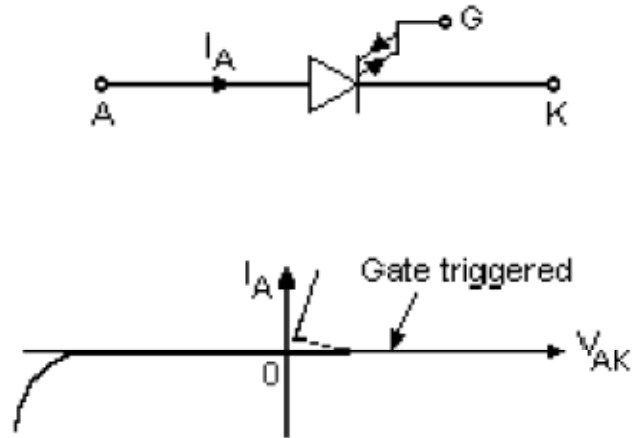

Figure 2.8: Characteristics and symbols of the power devices



c. GTO symbol

Figure 2.8: Characteristics and symbols of the power devices

Type of power transistor for inverter switching includes Metal-Oxide-Semiconductor Field Effect Transistor (MOSFET), Insulated Gate Bipolar Transistor (IGBT) and Gate Turn Off Thyristors (GTO). They all are classified as power semiconductor devices that are controlled turn on and off characteristic, unipolar voltage withstanding capability and unidirectional current capability [19]. Figure 2.8 shows the characteristic and symbols of the N-channel MOSFET, IGBT and GTO.

MOSFETs require the continuous operation of a gate-source voltage of appropriate magnitude in order to be in the on state. No gate current flows except during the transition from on to off or vice-versa when gate capacitance being charged or discharged. The switching time is very short, that is in range of nanoseconds to picoseconds depending on the device type. However, because of the switching speed is very fast, the switching losses can be very small according to equation (2.14) that shows the switching power loss in a semiconductor varies linearly with the switching frequency and the switching times. P_s indicates the average switching power loss, V_d is the input voltage appear across the switch, I_o is the conducting current when the switch is fully on, f_s is the switching frequency and t_{on} and t_{off} is the crossover interval between the V_d and I_o for the switch. Thus, for a power