

# Development of Control Circuit for Single Phase Inverter Using Atmel Microcontroller

B. Ismail<sup>1</sup>, S.Taib<sup>2</sup>, A.R Mohd Saad<sup>3</sup>, M. Isa<sup>4</sup>, I. Daut<sup>4</sup>

<sup>1</sup> School of Electrical System Engineering KUKUM and Msc Student School of Electrical and Electronic Engineering USM  
E-mail: [baha@kukum.edu.my](mailto:baha@kukum.edu.my)

<sup>2</sup> School of Electrical and Electronic Engineering USM  
E-mail: [soibtaib@eng.usm.my](mailto:soibtaib@eng.usm.my)

<sup>3</sup> Engineering Centre KUKUM,

<sup>4</sup> School of Electrical System Engineering KUKUM.

## Abstract

*This paper presents the development of control circuit for single phase inverter using Atmel microcontroller. The attractiveness of this configuration is the elimination of a microcontroller to generate sinusoidal pulse width modulation (SPWM) pulses. The Atmel microcontroller is able to store all the commands to generate the necessary waveforms to control the frequency of the inverter through proper design of switching pulse. In this paper concept of the single phase inverter and its relation with the microcontroller is reviewed first. Subsequently approach and methods and dead time control are discussed. Finally simulation results and experimental results are discussed.*

**Keywords:** Sinusoidal pulse width modulation, inverter and microcontroller.

## 1. Introduction

SPWM or sinusoidal pulse width modulation is widely used in power electronics to “digitize” the power so that a sequence of voltage pulses can be generated by the on and off of the power switches. The pulse width modulation inverter has been the main choice in power electronic for decades, because of its circuit simplicity and rugged control scheme [1]. SPWM switching technique is commonly used in industrial applications [2]. SPWM techniques are characterized by constant amplitude pulses with different duty cycle for each period. The width of these pulses are modulated to obtain inverter output voltage control and to reduce its harmonic content. Sinusoidal pulse width modulation or SPWM is the mostly used method in motor control and inverter application. Conventionally,

to generate the signal, triangle wave as a carrier signal is compared with the sinusoidal wave, whose frequency is the desired frequency.

This proposed method is conducted to replace the conventional method with the use of Atmel microcontroller. The use of the microcontroller brings flexibility to change the real-time control algorithms without further changes in hardware. It is also need low cost and has a small size of control circuit for the single phase bridge inverter.

To achieve the control system an Atmel AT89C2051-24PI microcontroller was used. The atmel AT89C2051-24PI is a low voltage, high performance CMOS 8-bit microcomputer with 2K bytes of Flash programmable and erasable read only memory (PEROM). The device is manufactured using Atmel’s high density nonvolatile memory technology and is compatible with the industry standard MCS-51 instruction set. It also has two 16-bit timers that deliver the function use in this application. By combining a versatile 8 bit CPU with Flash on a monolithic chip, the Atmel AT89C2051 is powerful microcomputer with provides a highly flexible and cost effective solution to many embedded control applications. Figure 1 presented the AT89C51-24PI pins assignment for the control system of SPWM in single phase inverter system.

The Atmel microcontroller is developed as the controller circuit to make the design of controller simpler, more reliable and the most important to reduce their dimensions and components. Only one component can perform the function of a whole circuit, being dependent on the project to be implemented by a small standalone Atmel microcontroller embedded in the converter system.

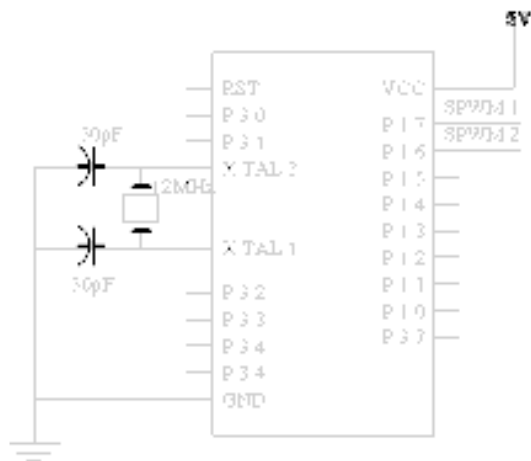

Figure 1 - Pins assignment for the control system of SPWM single phase inverter.

## 2. Full Bridge Single Phase Inverter

The DC to AC converter, also known as inverter converts dc power to ac power at desired output voltage and frequency [3]. The output voltage of an inverter has a periodic waveform that is not sinusoidal but can be made to closely approximate this desire waveform. Figure 2 shows the circuit topology for a full bridge inverter. It is an electronic power converter that is necessary as an interface between the power input and the load. The full bridge single phase inverter consists of the DC voltage source, four switching elements S1, S2, S3 and S4 and load.

The switching element available nowadays, such as bipolar junction transistor (BJTs), gate turn off thyristor (GTOs), metal oxide semiconductor field effect transistors (MOSFETs), insulated gate bipolar transistors (IGBTs), metal oxide semiconductor controlled thyristor (MCT's) and static induction transistors (SIT's) can be used as a switch. They are substituting the relays, magnetic switches and other magnetic components as the inverter switching devices. This makes use of microcontroller becomes more significant.

The full bridge single phase inverter has two legs, left or right or 'A' phase leg and 'B' phase leg. Each leg consists of two power devices (here MOSFET) connect in series. The load is connected between the midpoints of the two phase legs. Each power control device has a diode connected in anti-parallel to it. The diodes provide an alternative path for the load current if the power switches are turned OFF. For example, if lower MOSFET in the 'A' phase leg is

conducting and carrying current towards the negative DC bus, this current would 'commutate' into the diode across the upper MOSFET of the 'A' phase leg, if the lower MOSFET is turned OFF. Control of the circuit is accomplished by varying the turn on time of the upper and lower MOSFET of each inverter leg with the provision of never turning ON both at the same time, to avoid a short circuit of DC bus.

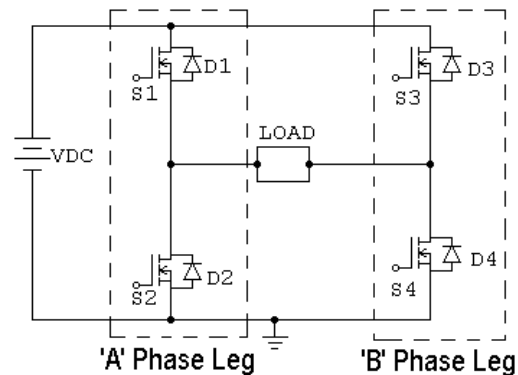

Figure 2 - Full Bridge Single Phase Inverter

## 3. Approach and Method

Figure 3 is the block diagram that describes the hardware development for controller circuit. The arrow shows the SPWM signal flow from Atmel microcontroller through the inverter.

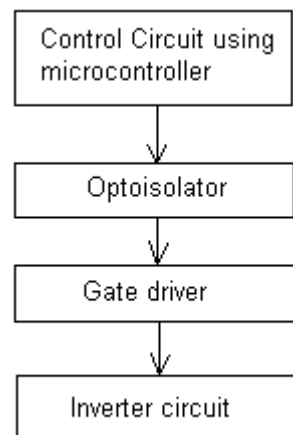

Figure 3 - Flow of Hardware Development

The switching frequency used in this project is 5 KHz. The software development includes designing suitable switching pulses with the use of the variable frequency and variable duty cycle PWM available inside the

microcontroller. It is desired to control the inverter with proper switching purposes. The digital implementation of the so called scalar modulation is usually achieved with a timer based card inside microcontroller [4]. Modulation technique that is used in this project is scalar modulation namely sinusoidal pulse width modulation (SPWM) method. The SPWM control signal is generated by using Atmel microcontroller. The turn on and turn off time of the switches is determined by this SPWM control signal. Before this control signal being generated, proper calculation is done to determine the suitable switching pulses conditions.

Figure 4 below show the switching strategy that is used in this research. The turn ON and OFF switch 1 (S1) and switch 4 (S4) are controlled by SPWM 1 generated at port 1.7 Atmel microcontroller. While the turn ON and OFF switch 2 (S2) and switch 3 (S3) are controlled by SPWM 2 generated at port 1.6 Atmel microcontroller. Both SPWM 1 and SPWM 2 used the same control signal generated by the microcontroller. The different is only SPWM 1 signal is leading SPWM 2 by half cycle or 180 degree of the switching signal.

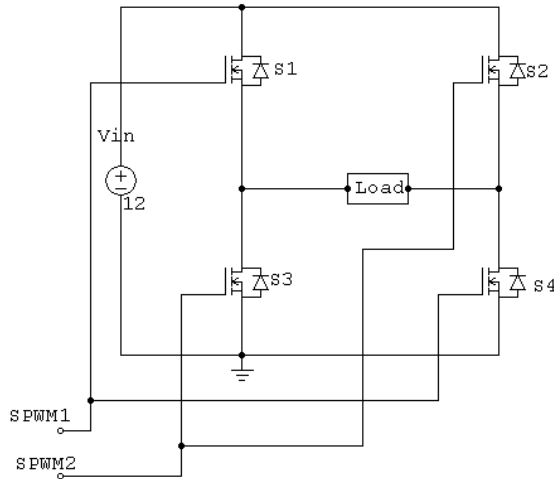

Figure 4 - Switching strategy for Single Phase Inverter

#### 4. Dead Time Control

One of the most important items to be considered is the dead time control. There is a possibility of overlapping between ON period switch pair (S1 and S4) and (S2 and S3) pair in full bridge single phase inverter. It's important to avoid the short

circuit of DC bus. The dead time can be control through programming by using Atmel microcontroller. Dead time period must be suitable to avoid the problem of damage the switch and harmonic problem. If the dead time to short it will damage the switch and if dead time to long it will increase the total harmonic distortion.

#### 5. Results and Discussion

The simulations have been performed using PSIM software to investigate the validity of the switching strategy. Figure 5 show the simulation result of SPWM 1 and SPWM 2 and Figure 6 show simulation result of output from single phase inverter. Tektronix TPS 2014, four channel digital storage oscilloscope was used to measure the experimental results. The experimental result from Atmel microcontroller output port is shown in Figure 7. SPWM 1 is output from port 1.7 and SPWM 2 is output from port 1.6 Atmel microcontrollers. SPWM 1 is leading SPWM 2 by half cycle of the switching signal. The output voltage of SPWM 1 and SPWM 2 generated by Atmel microcontroller is around 5V. This value is suitable to drive the switch. Figure 8 show the output waveform of full bridge single phase inverter. The frequency of the output waveform from simulation and experimental results is 50 Hz. This frequency is exactly equal to grid frequency. The output voltage of full bridge single phase inverter from simulation and experimental results is 12V. This value is equal to Vin. It is found that the experimental results agreed with the simulation results. Figure 9 show the dead time measurement of the full bridge single phase inverter. Dead time measured period is 180us. This value is suitable to avoid the problem of damage the switch and harmonic problem.

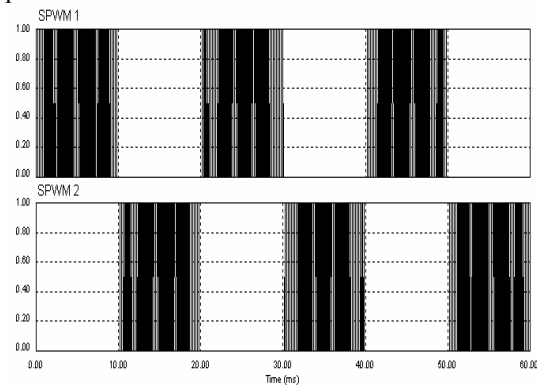

Figure 5 - Simulation result of SPWM 1 and SPWM 2

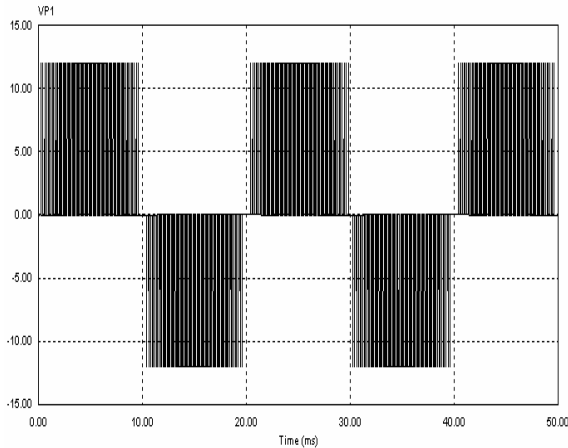

Figure 6 - Simulation result of output from single phase inverter



Figure 9 - Dead time measurement

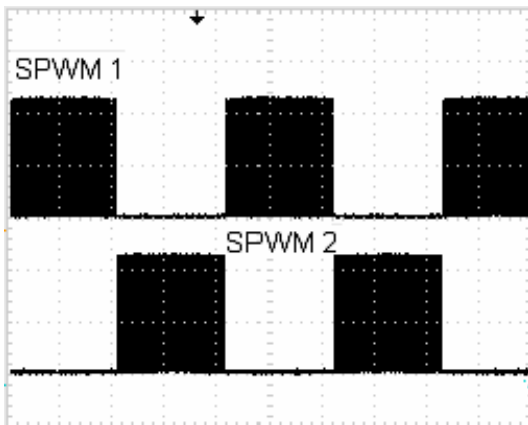

Figure 7 - SPWM 1 and SPWM 2 from port 1.7 and port 1.6 microcontrollers

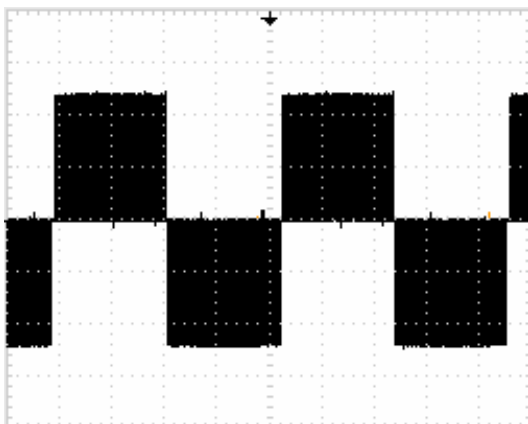

Figure 8 - Output from single phase inverter

## 6. Conclusion

The main task in this work is to develop the control circuit for single phase inverter using Atmel microcontroller. It is found that the results from experimental agreed with the simulation results. The controller board is able to produce the inverter output frequency at nearly 50 Hz, overall voltage and current THD found to be less than 4% and 8% respectively. The method used to control the inverter switches is sinusoidal pulse width modulation (SPWM). The control circuit using Atmel microcontroller is developed, therefore the inverter control circuit hardware is reduced. Using microcontroller unit, the frequency modulation ratio, dead time period and duty cycle can be easily change through programming without further hardware changes.

## References

- [1] Maria D. Bellar, Tzong-Shiann Wu, Aristide Tchamdjau, Javad Mahdavi and M. Ehsani. 1998. A Riview of Soft-switched DC-AC Converter. IEEE trans. On Industry Appl. Vol. 43 no. 4: 847-858.
- [2] Muhammad H. Rashid. 2004. Power Electronics; Circuit's Devices and Applications: Prentice Hall: 226-299.
- [3] Ashfaq Ahmed. 1999. Power Electronic and Technology: Prentice Hall: 304-327.
- [4] A.C. Oliveira, A.M.N. Lima and C.B. Jacobina. 2002. Varying the Switching Frequency to Compensate the Dead-time in Pulse Width Modulated Voltage Source Inverter. IEEE trans: 244-249.