UNIVERSITI SAINS MALAYSIA

Peperiksaan Semester Pertama
Sidang Akademik 2008/2009

November 2008

EEE241 – ELEKTRONIK ANALOG I

Masa: 3 jam

Sila pastikan bahawa kertas peperiksaan ini mengandungi **SEBELAS** muka surat dan **DUA** muka surat **LAMPIRAN** yang bercetak sebelum anda memulakan peperiksaan ini.

Kertas soalan ini mengandungi **ENAM** soalan.

Jawab **LIMA** soalan.

Mulakan jawapan anda untuk setiap soalan pada muka surat yang baru.

Agihan markah bagi setiap soalan diberikan di sudut sebelah kanan soalan berkenaan.

Jawab semua soalan dalam bahasa Malaysia atau bahasa Inggeris atau kombinasi kedua-duanya.

1. (a) Terangkan fenomena berikut:
Explain the following phenomenon:

(i) pemodulatan panjang-saluran dalam MOSFET
channel-length modulation in MOSFETs (4 marks)

(ii) kesan badan dalam MOSFET
body effect in MOSFETs (4 marks)

(b) Tentukan mod operasi NMOSFET dalam Rajah 1. Seterusnya, tentukan titik-Q (I_D dan V_{DS}) bagi NMOS yang sama. $K_n = \mu_n C_{ox} W/L = 250 \mu A/V^2$ dan voltan ambang, $V_{tn} = 1 V$.

Determine the mode of operation of the NMOSFET in Figure 1. Subsequently, determine the Q-point (I_D and V_{DS}) for the same NMOS. $K_n = \mu_n C_{ox} W/L = 250 \mu A/V^2$ and the threshold voltage, $V_{tn} = 1 V$.

(12 marks)

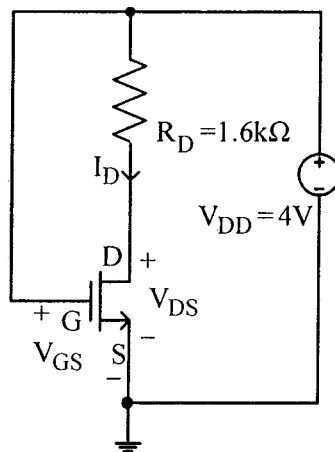

Rajah 1
Figure 1

2. (a) (i) Beri takrifan bagi masa transit tapak.
Define the base transit time.

(2 marks)

- (ii) Merujuk kepada Rajah 2, nyatakan samaada C_1, C_2 dan C_3 adalah kapasitor gandingan atau pirau. Apakah kegunaan kapasitor-kapasitor ini?

Referring to Figure 2, state whether C_1, C_2 and C_3 are coupling or bypass capacitors. What are the applications of these capacitors?

(6 marks)

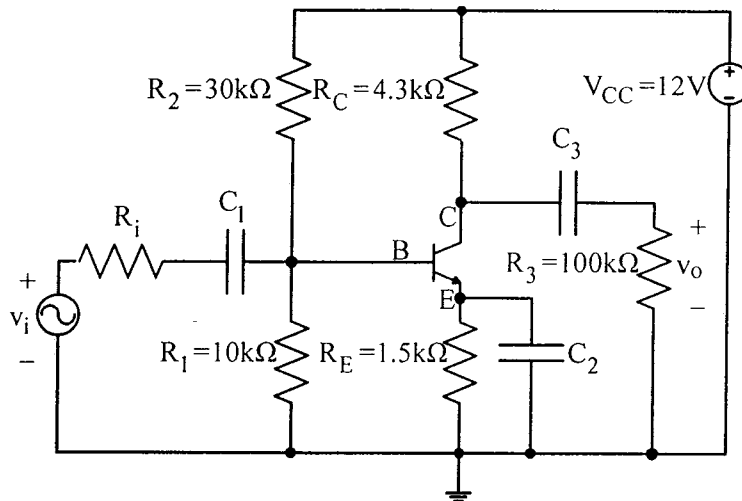

Rajah 2
Figure 2

- (b) (i) Kirakan gandaan voltan bagi penguat pemancar-sepunya dalam Rajah 2 jika transistor mempunyai $\beta_o = \beta_F = 100$, $V_T = 26$ mV dan $V_A = 75$ V. $I_C = 1.45$ mA dan $V_{CE} = 3.41$ V.

Calculate the voltage gain of the common-emitter amplifier in Figure 2 if the transistor has $\beta_o = \beta_F = 100$, $V_T = 26$ mV and $V_A = 75$ V. $I_C = 1.45$ mA and $V_{CE} = 3.41$ V.

...4/-

- (ii) Buktikan bahawa r_o tidak terlalu mempengaruhi gandaan voltan dalam (i).

Prove that r_o will not influence the voltage gain in (i) significantly.

- (iii) Jika isyarat masukan, v_i , dalam Rajah 2 ialah satu isyarat 1-mV, 1-kHz, tentukan amplitud isyarat keluaran.

If the input signal, v_i , in Figure 2 is a 1-mV, 1-kHz signal, determine the amplitude of the output signal.

(12 marks)

3. (a) (i) Bandingkan prestasi ketiga-tiga konfigurasi penguat BJT dari segi rintangan masukan dan keluaran dan gandaan voltan dan arus. Nyatakan 1 kegunaan bagi setiap satu konfigurasi berdasarkan kepada hasil daripada perbandingan tersebut.

Make comparison on the performances of the 3 BJT amplifier configurations in terms of their input and output resistances and voltage and current gains. State 1 application of each configuration based on the result of your comparison.

(6 marks)

- (ii) Bandingkan prestasi konfigurasi penguat pemancar-sepunya dan punca-sepunya dari segi rintangan masukan dan keluaran dan gandaan voltan dan arus. Daripada hasil perbandingan tersebut, nyatakan kenapa MOSFET semakin popular sebagai penguat.

Make comparison on the performances of the common-emitter and common-source amplifier configurations in terms of their input and output resistances and voltage and current gains. From the results of your comparison, write the reasons why MOSFETs are gaining popularity as amplifiers.

(4 marks)

...5/-

- (b) Satu daripada perkara paling awal mesti dilakukan bagi menyelesaikan masalah rekabentuk litar ialah untuk menentukan topologi/konfigurasi litar yang perlu digunakan. Jika satu penguat dengan rintangan keluaran 25Ω diperlukan, apakah topologi yang anda cadangkan? Bandingkan jumlah arus yang anda jangka akan digunakan jika penguat tersebut menggunakan MOSFET atau BJT. Apakah nisbah W/L yang diperlukan oleh litar penguat MOSFET dalam topologi berkenaan?

One of the first thing we must do to solve a circuit design problem is to decide on the circuit topology/configuration to be used. If an amplifier is needed with an output resistance of 25Ω , what topology that you can suggest to be used? Make comparison on the amount of current to be used if the amplifier is to utilize a MOSFET or a BJT. What is the W/L ratio required by the MOSFET amplifier circuit with the mentioned topology?

(10 marks)

4. Pada Rajah 3, transistor dwikutub kaskod yang mengandungi pemancar-sepunya menjana tapak-sepunya ditunjuk. Ciri-ciri penting di dalam menganalisa litar ini adalah rintangan masukan R_i , rintangan keluaran R_o , kealiran pindah G_m , dan gandaan voltan A_v . Andaikan rintangan tapak r_b diabaikan.

In Figure 3, the bipolar cascode transistor that constitutes the common-emitter driving the common-base is shown. The key characteristics in analyzing this circuit are the input resistance R_i , output resistance R_o , system transconductance G_m , and the voltage gain A_v . We will assume that base resistance r_b is negligible.

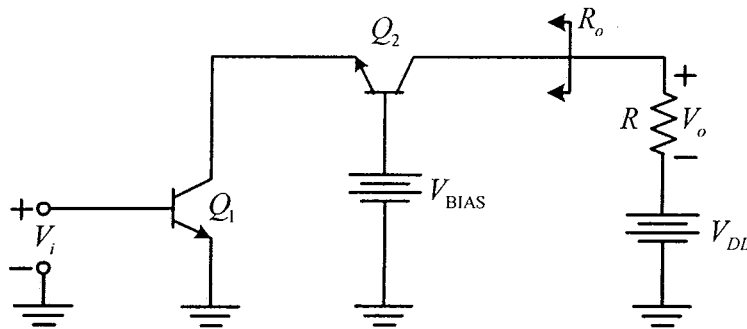

Rajah 3
Figure 3

- (a) Lukis litar setara isyarat kecil menggunakan model π . Tandakan litar sepenuhnya.

Draw the small signal equivalent circuit using π -model. Label the circuit completely.

(5 marks)

- (b) Cari rintangan masukan R_i , dan sistem kealiran pindah G_m .

Find input resistance R_i , and the system transconductance G_m .

(5 marks)

- (c) Buktikan rintangan keluaran R_o sebagai

Prove the output resistance R_o is given by

Saranan: Menggunakan model isyarat kecil, nyatakan andaian-andaian yang perlu bagi menentukan rintangan keluaran.

Hint: Using the small-signal model, set up the requirement to determine the output resistance

$$R_o = r_{o2} \left(1 + \frac{g_{m2} r_{o1}}{1 + \frac{g_{m2} r_{o1}}{\beta_0}} \right)$$

(5 marks)

- (d) Cari gandaan voltan A_v .

Find the voltage gain A_v .

(5 marks)

5. Sebuah litar pengikut-punca diberi seperti pada Rajah 4 yang digunakan sebagai peringkat keluaran kelas A. Voltan ambang untuk transistor M_1 adalah didefinisikan sebagai

A source follower circuit is given as shown in Figure 4 to be utilized as a Class A output stage. The threshold voltage of transistor M_1 can be defined as

$$V_m = V_{t0} + \gamma \left(\sqrt{2\phi_f + V_o + V_{DD}} - \sqrt{2\phi_f} \right).$$

... 8/-

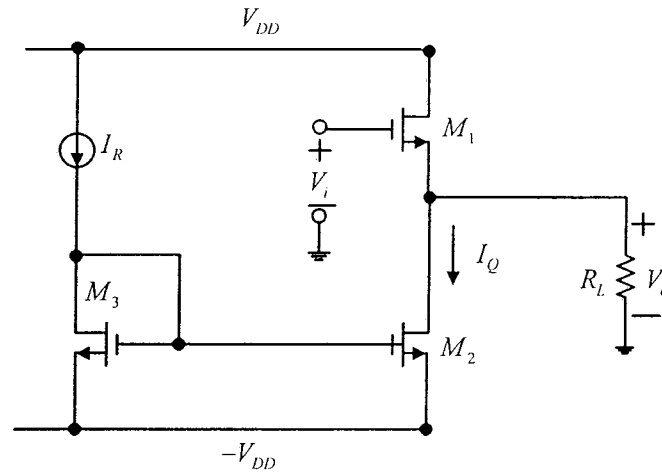

Rajah 4
Figure 4

- (a) Takrif ciri isyarat pindah besar menggunakan voltan ambang yang dinyatakan.

Define the large signal transfer characteristic using the mentioned threshold voltage above.

(5 marks)

- (b) Lukis ciri isyarat pindah dengan label yang terperinci. Terangkan operasi bagi pengikut-punca sebagai penguat kelas A.

Saranan: Tanda pada 4 posisi pada paksi y dan 3 posisi pada paksi x.

Draw the transfer characteristic with detailed labels. Explain the operation of the source follower as the class A amplifier.

Hint: Label 4 positions on the y-axis and 3 positions on the x-axis.

(5 marks)

- (c) Lukis rajah isyarat kecil. Abaikan litar cermin arus iaitu I_R , M_2 dan M_3 .

Draw the small signal model. Neglect the current mirror circuit, i.e. I_R , M_2 and M_3 .

(5 marks)

- (d) Cari gandaan voltan A_v bagi menentukan kecerunan ciri pindah berdasarkan kepada model isyarat kecil di atas.

Find the voltage gain A_v to represent the slope of the transfer characteristic based on the small signal model above.

(5 marks)

6. Penguat pemancar sepunya ditunjukkan pada Rajah 5 digunakan dengan meluas kerana ia mampu memberi penguat voltan yang baik. Walaubagaimanapun, sambutan frekuensi perlu dianalisa untuk menghasilkan satu kutub perusa supaya sistem di dalam keadaan stabil bersyarat. Juga isu dengan kesan Miller yang akan mengurangkan sambutan frekuensi di mana terdapat kesan kemuatan di antara keluaran ke masukan perlu diambil kira. Menggunakan kira hampir model isyarat kecil untuk sambutan frekuensi seperti pada Rajah 6, cari kutub berdasarkan kepada prosedur berikut. Dari Rajah 6, penguat voltan A_v adalah diberi sebagai

The common-emitter amplifier shown in Figure 5 is widely used as it provides us with high voltage gain. However, the frequency response needs to be analyzed in order for us to achieve a single-dominant pole solution so that the system will be conditionally stable. In addition, the issue with Miller effect that will reduce the frequency response as there will be strong capacitance between the output to the input needs to be addressed. Using small signal approximation as shown in Figure 6, find the pole using the following procedure. From Figure 6, the voltage gain A_v is given as

$$A_v = \frac{v_o}{v_i} = -g_m R_L \frac{r_{in}}{R_s + r_x + r_{in}} \frac{1}{1 + sC_t \frac{(R_s + r_x)r_{in}}{R_s + r_x + r_{in}}}$$

...10/-

- (b) Cari kutub perusa p_1 bagi permasalahan di atas.
Saranan: Gunakan persamaan berikut.

Find the dominant pole for the above problem.

Hint: Use the following relation

$$A(s) = K \frac{1}{1 - \frac{s}{p_1}}$$

(5 marks)

- (c) Cari frekuensi radian 3-dB, ω_{3dB} , dengan mengaitkannya dengan nilai kutub perusa p_1 di atas dan dengan menggunakan nilai kekuatan seluruh C_t .

Saranan: Kekuatan seluruh diberikan sebagai

Find the 3-dB radian frequency ω_{3dB} by relating it to the dominant pole p_1 above and by using the total capacitance C_t .

Hint: The total capacitance is given as follows

$$C_t = C_M + C_{in}$$

di mana C_m ialah kekuatan Miller dan C_{in} ialah kekuatan masukan.

where C_M is the Miller capacitance and C_{in} is the input capacitance.

(10 marks)

oooo00oooo

APPENDIX

A.1.1 SUMMARY OF ACTIVE-DEVICE PARAMETERS

(a) npn Bipolar Transistor Parameters

Quantity	Formula
Large-Signal Forward-Active Operation	
Collector current	$I_C = I_S \exp \frac{V_{BE}}{V_T}$
Small-Signal Forward-Active Operation	
Transconductance	$g_m = \frac{qI_C}{kT} = \frac{I_C}{V_T}$
Transconductance-to-current ratio	$\frac{g_m}{I_C} = \frac{1}{V_T}$
Input resistance	$r_\pi = \frac{\beta_0}{g_m}$
Output resistance	$r_o = \frac{V_A}{I_C} = \frac{1}{\eta g_m}$
Collector-base resistance	$r_\mu = \beta_0 r_o$ to $5\beta_0 r_o$
Base-charging capacitance	$C_b = \tau_F g_m$
Base-emitter capacitance	$C_\pi = C_b + C_{je}$
Emitter-base junction depletion capacitance	$C_{je} \approx 2C_{je0}$
Collector-base junction capacitance	$C_\mu = \frac{C_{\mu 0}}{\left(1 - \frac{V_{BC}}{\psi_{0c}}\right)^{nc}}$

(continued)

Quantity	Formula
Small-Signal Forward-Active Operation	
Collector-substrate junction capacitance	$C_{cs} = \frac{C_{cs0}}{\left(1 - \frac{V_{SC}}{\psi_{0s}}\right)^{nc}}$
Transition frequency	$f_T = \frac{1}{2\pi} \frac{g_m}{C_\pi + C_\mu}$
Effective transit time	$\tau_T = \frac{1}{2\pi f_T} = \tau_F + \frac{C_{je}}{g_m} + \frac{C_\mu}{g_m}$
Maximum gain	$g_m r_o = \frac{V_A}{V_T} = \frac{1}{\eta}$

(b) NMOS Transistor Parameters

Quantity	Formula
Large-Signal Operation	
Drain current (active region)	$I_d = \frac{\mu C_{ox} W}{2 L} (V_{gs} - V_t)^2$
Drain current (triode region)	$I_d = \frac{\mu C_{ox} W}{2 L} [2(V_{gs} - V_t)V_{ds} - V_{ds}^2]$
Threshold voltage	$V_t = V_{t0} + \gamma \left[\sqrt{2\phi_f + V_{sb}} - \sqrt{2\phi_f} \right]$
Threshold voltage parameter	$\gamma = \frac{1}{C_{ox}} \sqrt{2q\epsilon N_A}$
Oxide capacitance	$C_{ox} = \frac{\epsilon_{ox}}{t_{ox}} = 3.45 \text{ fF}/\mu\text{m}^2 \text{ for } t_{ox} = 100 \text{ \AA}$
Small-Signal Operation (Active Region)	
Top-gate transconductance	$g_m = \mu C_{ox} \frac{W}{L} (V_{GS} - V_t) = \sqrt{2I_D \mu C_{ox} \frac{W}{L}}$
Transconductance-to-current ratio	$\frac{g_m}{I_D} = \frac{2}{V_{GS} - V_t}$
Body-effect transconductance	$g_{mb} = \frac{\gamma}{2\sqrt{2\phi_f + V_{SB}}} g_m = \chi g_m$
Channel-length modulation parameter	$\lambda = \frac{1}{V_A} = \frac{1}{L_{eff}} \frac{dX_d}{dV_{DS}}$
Output resistance	$r_o = \frac{1}{\lambda I_D} = \frac{L_{eff}}{I_D} \left(\frac{dX_d}{dV_{DS}} \right)^{-1}$
Effective channel length	$L_{eff} = L_{drwn} - 2L_d - X_d$
Maximum gain	$g_m r_o = \frac{1}{\lambda} \frac{2}{V_{GS} - V_t} = \frac{2V_A}{V_{GS} - V_t}$
Source-body depletion capacitance	$C_{sb} = \frac{C_{sb0}}{\left(1 + \frac{V_{SB}}{\psi_0}\right)^{0.5}}$

(continued)

Quantity	Formula
Small-Signal Operation (Active Region)	
Drain-body depletion capacitance	$C_{db} = \frac{C_{db0}}{\left(1 + \frac{V_{DB}}{\psi_0}\right)^{0.5}}$
Gate-source capacitance	$C_{gs} = \frac{2}{3} W L C_{ox}$
Transition frequency	$f_T = \frac{g_m}{2\pi(C_{gs} + C_{gd} + C_{gb})}$