

---

# UNIVERSITI SAINS MALAYSIA

Second Semester Examination  
Academic Session 2008/2009

April/Mei 2009

## EBB 316/3 - Corrosion & Degradation [Kakisan & Degradasi]

Duration : 3 hours  
[Masa : 3 jam]

---

Please ensure that this examination paper contains TWELVE printed pages and ONE page APPENDIX before you begin the examination.

*[Sila pastikan bahawa kertas peperiksaan ini mengandungi DUA BELAS muka surat beserta SATU muka surat LAMPIRAN yang bercetak sebelum anda memulakan peperiksaan ini.]*

This paper contains SEVEN questions. THREE questions in PART A, TWO questions in PART B and TWO questions in PART C.

*[Kertas soalan ini mengandungi TUJUH soalan. TIGA soalan di BAHAGIAN A, DUA soalan di BAHAGIAN B dan DUA soalan di BAHAGIAN C.]*

**Instruction:** Answer **FIVE** questions. Answer **ONE** question from PART A, **ONE** question from PART B, **ONE** question from PART C and **TWO** questions from any sections. If candidate answers more than five questions only the first five questions answered in the answer script would be examined.

**Arahan:** Jawab **LIMA** soalan. Jawab **SATU** soalan dari BAHAGIAN A, **SATU** soalan dari BAHAGIAN B, **SATU** soalan dari BAHAGIAN C dan **DUA** soalan dari mana-mana bahagian. Jika calon menjawab lebih daripada lima soalan hanya lima soalan pertama mengikut susunan dalam skrip jawapan akan diberi markah.]

The answers to all questions must start on a new page.

*[Mulakan jawapan anda untuk semua soalan pada muka surat yang baru.]*

You may answer a question either in Bahasa Malaysia or in English.

*[Anda dibenarkan menjawab soalan sama ada dalam Bahasa Malaysia atau Bahasa Inggeris.]*

**PART A****BAHAGIAN A**

1. [a] What general electrochemical process occurs during an anodic reaction? Write an equation for a typical anodic corrosion reaction.

*Apakah proses elektrokimia umum yang berlaku semasa tindakbalas anodik? Tuliskan suatu persamaan untuk tindakbalas tipikal kakisan anod.*

(10 marks/markah)

- [b] List the factors affecting corrosion resistance of a metal.

*Senaraikan faktor-faktor yang mempengaruhi kerintangan kakisan suatu logam.*

(20 marks/markah)

- [c] What is the effect of velocity (or agitation) on corrosion rate? Carefully explain your answer.

*Apakah kesan halaju (atau pengadukan) ke atas kadar kakisan? Terangkan jawapan anda dengan berhati-hati.*

(40 marks/markah)

- [d] For the case of iron in diluted HCl, what will be the effect of velocity on corrosion rate? Explain.

*Dalam kes besi di dalam asid HCl cair, apakah kesan halaju ke atas kadar kakisan? Terangkan.*

(30 marks/markah)

2. [a] Describe activation polarization and concentration polarization.

*Perihalkan pengutuban pengaktifan dan pengutuban kepekatan.*

(30 marks/markah)

- [b] Sketch the Evan diagrams showing the various types of corrosion control.

*Lakarkan gambarajah Evan menunjukkan pelbagai jenis kawal kakisan.*

(30 marks/markah)

- [c] The corrosion potential of mild steel in a deaerated solution of pH 2 is  $-0.64V$  versus saturated  $Cu/CuSO_4$  half-cell. The hydrogen overvoltage (volts) for the same steel follows the relation  $0.7 + 0.1 \log i$ , where  $i = A\ cm^{-2}$ . Assuming that approximately all the steel surface acts as cathode, calculate the corrosion rate in  $A\ cm^{-2}$ .

(Note: For saturated  $Cu/CuSO_4$ , the potential is  $0.316V$ ).

*Keupayaan kakisan untuk keluli lembut di dalam larutan nyahudara pH 2 adalah  $-0.64V$  melawan sel-setengah  $Cu/CuSO_4$  tepu. Keupayaan lampau hidrogen (volts) untuk keluli ini mematuhi perhubungan  $0.7 + 0.1 \log i$ , iaitu  $i = A\ cm^{-2}$ . Andaikan hampir keseluruhan permukaan keluli bertindak sebagai katod, hitungkan kadar kakisan dalam  $A\ cm^{-2}$ .*

(Nota: Untuk  $Cu/CuSO_4$  tepu, keupayaannya adalah  $0.316V$ ).

(40 marks/markah)

3. [a] What is an E-pH diagram. Explain.

*Apakah gambarajah E-pH. Terangkan.*

(40 marks/markah)

- [b] A typical active-passive metal is passivated by placing it in a solution containing a large quantity of oxidizing agent. For such a system, what happens to the corrosion rate during anodic polarization? During cathodic polarization? Explain your answer with the aid of appropriate diagrams.

*Suatu logam aktif-pasif tipikal dipasifkan dengan merendamnya di dalam larutan mengandungi agen pengoksida yang banyak. Untuk sistem tersebut, apakah yang terjadi ke atas kadar kakisan semasa pengutuban anod? Semasa pengutuban katod? Terangkan jawapan anda dengan berbantuan gambarajah yang sesuai.*

(60 marks/markah)

**PART B****BAHAGIAN B**

4. [a] Figure 1 shows a steel-based metal surface. Name the type of corrosion evident?

*Rajah 1 menunjukkan permukaan logam berasaskan besi. Namakan apakah jenis pengkaratan ini?*

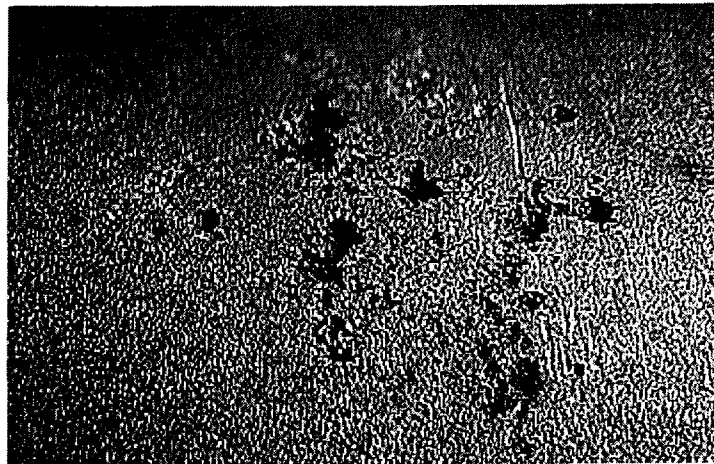

**Figure 1**

*Rajah 1*

(10 marks/markah)

- [b] Figure 2 shows the results from electrochemical impedance spectroscopy studies for painted mild steel sample in NaCl solution.

*Rajah 2 menunjukkan keputusan kajian elektrokimia impedan spektroskopi untuk sampel besi lembut dicat di dalam larutan NaCl.*

- (i) Design and label the basic equipment/components for this measurement.

*Reka dan labelkan peralatan/komponen asas untuk pengukuran ini.*

(20 marks/markah)

- (ii) Based on your answer in b(i), explain the function for each component.

*Berdasarkan jawapan dalam b(ii), terangkan fungsi untuk setiap komponen.*

(20 marks/markah)

- (iii) What is the minimum corrosion resistance ( $R_{corr}$ ) value if the sample is considered to have good corrosion resistant coating?

*Apakah nilai minimum penghalang karat ( $R_{corr}$ ) jika sampel dikira sebagai penghalang karat yang baik?*

(10 marks/markah)

- (iv) Explain the  $R_{corr}$  behavior for Samples A, B and C as in Figure 2.

*Terangkan ciri  $R_{corr}$  untuk sample A, B dan C seperti di dalam Rajah 2.*

(30 marks/markah)

- (v) What conclusion can be made based on these results?

*Apakah kesimpulan yang boleh dibuat berdasarkan keputusan-keputusan ini?*

(10 marks/markah)

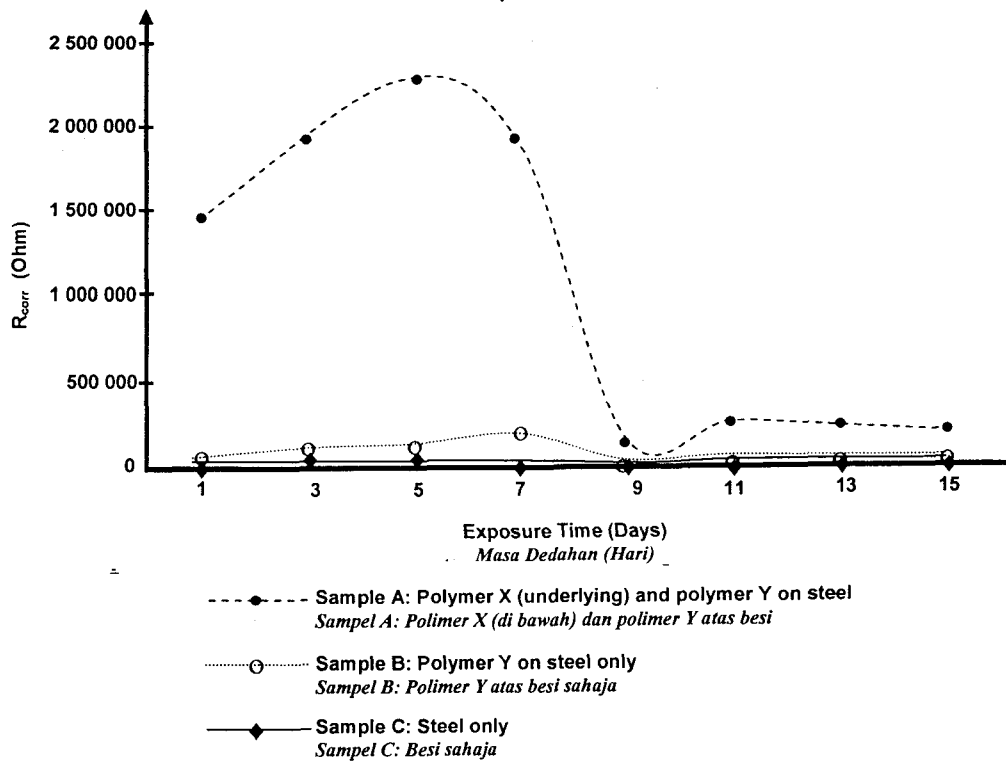

**Figure 2**

*Rajah 2*

5. [a] Figure 3 shows the corroded bolts, washer and nuts. The bolt is made from steel and the washer and nuts are made of brass. What type of corrosion is this?

*Rajah 3 menunjukkan 'bolts', 'washer' dan 'nuts' yang berkarat. 'Bolt' dibuat daripada besi, 'washer' dan 'nuts' dibuat dari Loyang. Apakah jenis pengkaratan ini?*

(10 marks/markah)

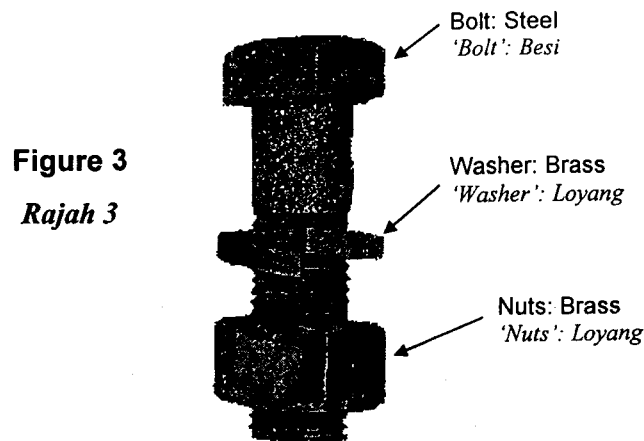

**Figure 3**

*Rajah 3*

- [b] Figure 4 shows the results from testing the polarization behavior of Sn-8.5Zn-0.25Ag-0.1Al-0.5Ga solders. The sample was tested in de-aerated 3.5% NaCl solution. A Pt wire and Ag/AgCl electrode were used as the counter and reference electrodes, respectively. The potential was scanned from -2000 to +100 mV at a scan rate of 1 mV/s. Based on Figure 4, describe the reaction that occurred:

*Rajah 4 menunjukkan keputusan dari ciri polarisasi untuk bahan pateri Sn-8.5Zn-0.25Ag-0.1Al-0.5Ga. Sampel telah diuji dalam larutan 3.5% NaCl nyah-udara. Wayar elektrod Pt dan Ag/AgCl digunakan sebagai elektrod pembilang dan rujukan. Keupayaan diimbis dari -2000 ke +100 mV pada kadar imbasan 1 mV/s. Berdasarkan Rajah 4, terangkan tindakbalas yang berlaku:*

- (i) in the region A-B

*Pada kawasan A-B*

(10 marks/markah)

- (ii) at B

*Pada B*

(20 marks/markah)

- (iii) in the region C-D

*Pada kawasan C-D*

(20 marks/markah)

- (iv) in the region E-F

*Pada kawasan E-F*

(20 marks/markah)

- (v) in the region F-G

*Pada kawasan F-G*

(20 marks/markah)



Hints: Electrochemistry reactions

*Pembayang: Tindakbalas elektrokimia*

1.  $2\text{H}_2\text{O} + 2\text{e}^- \leftrightarrow 2(\text{OH})^- + \text{H}_2$
2.  $\text{Zn} + 2\text{OH}^- = \text{Zn}(\text{OH})_2 + 2\text{e}^-$   $E^0_{\text{SCE}} = -1208 \text{ mV}$
3.  $\text{Zn} + 2\text{OH}^- = \text{ZnO} + \text{H}_2\text{O} + 2\text{e}^-$   $E^0_{\text{SCE}} = -1211 \text{ mV}$
4. SCE differs from Ag/AgCl by 0.052 V

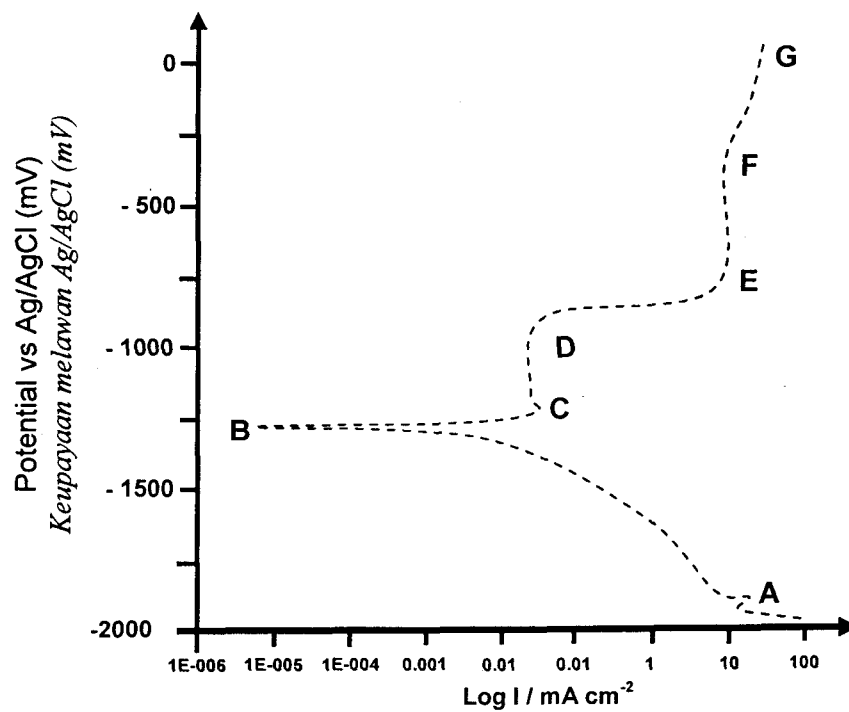

Figure 4

*Rajah 4*

**PART C****BAHAGIAN C**

6. [a] The best way to minimize corrosion in a flowing water system (e.g. water pipelines) is at the fabrication and design stages. Discuss this statement and outline at least 4 suggestions that can be applied to minimize corrosion in such system.

*Cara terbaik untuk mengurangkan kakisan dalam sistem air mengalir (perpaipan air) adalah pada peringkat pembuatan dan rekabentuk. Bincangkan pernyataan ini dan terangkan sekurang-kurangnya 4 cadangan yang boleh diaplikasikan untuk meminimalkan kakisan dalam sistem tersebut.*

(40 marks/markah)

- [b] Explain the following regarding inhibitors:

- (i) Why are inhibitors needed to be injected in pipelines transporting oil and gases?
- (ii) Why are inhibitors bonded by chemisorption more effective than inhibitors bonded by physical adsorption?
- (iii) What is the difference between cathodic protection and corrosion inhibition?

*Terangkan mengenai perencat yang berikut:*

- (i) *Mengapa perencat perlu disuntik dalam paip penghantaran minyak dan gas?*
- (ii) *Mengapa perencat yang diikat oleh penyerapan kimia lebih berkesan berbanding perencat diikat oleh penyerapan fizikal?*
- (iii) *Apakah perbezaan di antara perlindungan katodik dan perencatan kakisan?*

(60 marks/markah)

7. [a] A company is handed a contract to install an oil pipeline about 100 km long. The pipe will be above ground (off and on-shore for 45 km), underneath a river bed (0.8 km), and underground for the remaining length (various ground condition). Discuss:
- (i) A suitable protection method that can be applied in each case. State your reasons.
  - (ii) Design considerations that have to be made.
  - (iii) Factors that needs to be taken into consideration when selecting material for the pipe.

*Satu syarikat telah diberikan kontrak memasang paip minyak sepanjang 100 km. Paip tersebut akan berada di atas tanah (luar dan pesisir pantai sepanjang 45 km), di bawah dasar sungai (0.8 km) dan di bawah tanah untuk panjang paip yang selebihnya (keadaan tanah pelbagai). Bincangkan:*

- (i) Kaedah perlindungan sesuai yang boleh digunakan bagi setiap kes. Berikan alasan-alasan anda.*
- (ii) Pertimbangan rekabentuk yang perlu diaplikasikan.*
- (iii) Faktor-faktor yang perlu dipertimbangkan apabila memilih bahan untuk paip tersebut.*

(60 marks/markah)

- [b] Calculate the life of an Mg anode bed and its current output from the following data:

Driving potential of Mg anode = 6 V

Resistance = 5.18 ohms

Weight of Mg per anode = 5 x 10 = 50 kg (5 anodes to a bed)

Consumption rate = 0.215 A-year/kg

Efficiency of Mg anode = 0.6

Utilization factor = 0.85

*Kirakan hayat satu pelantar anod dan keluaran arusnya daripada data berikut:*

*Keupayaan pacuan anod Mg = 6 V*

*Kerintangan = 5.18 ohms*

*Berat Mg setiap anod = 5 x 10 = 50 kg (5 anod bagi satu pelantar)*

*Kadar penggunaan = 0.215 setahun/kg*

*Keefisienan anod Mg = 0.6*

*Faktor penggunaan = 0.85*

(40 marks/markah)

**Appendix****Lampiran****Constant Value**

Avogadro's constant ( $N_A$ )	$6.02 \times 10^{23} \text{ mol}^{-1}$
Boltzmann constant ( $k$ )	$1.38 \times 10^{-23} \text{ JK}^{-1}$ $8.62 \times 10^{-5} \text{ eV/atom-K}$
Coulomb constant ( $k$ )	$9.0 \times 10^9 \text{ N.m}^2/\text{C}^2$
Electron charge ( $e$ )	$1.60 \times 10^{-19} \text{ C}$
Electron Mass ( $m_e$ )	$9.11 \times 10^{-31} \text{ kg}$
Faraday's constant	96500 C/mole (i.e. amp.sec/mole)
Gas constant ( $R$ )	$8.31 \text{ JK}^{-1}\text{mol}^{-1}$
Gravity ( $g$ )	$9.81 \text{ ms}^{-2}$
Permeability of a vacuum ( $\mu_0$ )	$4\pi \times 10^{-7} \text{ ms}^{-1}$
Permittivity of a vacuum ( $\epsilon_0$ )	$8.85 \times 10^{-12} \text{ Fm}^{-1}$
Planck constant ( $h$ )	$6.63 \times 10^{-34} \text{ Js}$
Velocity of light in a vacuum ( $c$ )	$3.00 \times 10^8 \text{ ms}^{-1}$

**Periodic Table**

Key

- Atomic number
- Symbol
- Atomic weight

Metal

Nonmetal

Intermediate

IA																	0	
1 H 1.0080																	2 He 4.0026	
	IIA											IIIA	IVA	VA	VIA	VIIA		
3 Li 6.939	4 Be 9.0122											5 B 10.811	6 C 12.011	7 N 14.007	8 O 15.999	9 F 18.998	10 Ne 20.183	
11 Na 22.990	12 Mg 24.312	IIIB	IVB	VB	VIB	VIIIB	VIII				IB	IIB	13 Al 26.982	14 Si 28.086	15 P 30.974	16 S 32.064	17 Cl 35.453	18 Ar 39.948
19 K 39.102	20 Ca 40.08	21 Sc 44.956	22 Ti 47.90	23 V 50.942	24 Cr 51.996	25 Mn 54.938	26 Fe 55.847	27 Co 58.933	28 Ni 58.71	29 Cu 63.54	30 Zn 65.37	31 Ga 69.72	32 Ge 72.59	33 As 74.922	34 Se 78.96	35 Br 79.91	36 Kr 83.80	
37 Rb 85.47	38 Sr 87.62	39 Y 88.91	40 Zr 91.22	41 Nb 92.91	42 Mo 95.94	43 Tc (99)	44 Ru 101.07	45 Rh 102.91	46 Pd 106.4	47 Ag 107.87	48 Cd 112.40	49 In 114.82	50 Sn 118.69	51 Sb 121.75	52 Te 127.60	53 I 126.90	54 Xe 131.30	
55 Cs 132.91	56 Ba 137.34	Rare earth series	72 Hf 178.49	73 Ta 180.95	74 W 183.85	75 Re 186.2	76 Os 190.2	77 Ir 192.2	78 Pt 195.09	79 Au 196.97	80 Hg 200.59	81 Tl 204.37	82 Pb 207.19	83 Bi 208.98	84 Po (210)	85 At (210)	86 Rn (222)	
87 Fr (223)	88 Ra (226)	Actinide series																
Rare earth series		57 La 138.91	58 Ce 140.12	59 Pr 140.91	60 Nd 144.24	61 Pm (145)	62 Sm 150.35	63 Eu 151.96	64 Gd 157.25	65 Tb 158.92	66 Dy 162.50	67 Ho 164.93	68 Er 167.26	69 Tm 168.93	70 Yb 173.04	71 Lu 174.97		
Actinide series		89 Ac (227)	90 Th 232.04	91 Pa (231)	92 U 238.03	93 Np (237)	94 Pu (242)	95 Am (243)	96 Cm (247)	97 Bk (247)	98 Cf (249)	99 Es (254)	100 Fm (253)	101 Md (256)	102 No (254)	103 Lw (257)		