UNIVERSITI SAINS MALAYSIA

First Semester Examination
Academic Session 2008/2009

November 2008

EAS 663/4 – Dynamics And Stability Of Structures

Duration: 3 hours

Please check that this examination paper consists of **SEVEN (7)** pages of printed material before you begin the examination.

Instructions: Answer **FIVE (5)** questions. All questions carry the same marks.

You may answer the question either in Bahasa Malaysia or English.

All questions **MUST BE** answered on a new sheet.

Write the answered question numbers on the cover sheet of the answer script.

1. (a) Define viscous damping. Sketch the displacement response, (v) versus (t) of undamped and damped SDOF systems for free vibration. Does the natural period of vibration, T , change in the presence of damping?

[6 marks]

- (b) Figure 1 shows one-story building is idealized as a rigid girder to supports a rotating machine. A horizontal force, $F(t)=700 \cos 5.3 t$ N is exerted on the girder. Assume the damping of the system is equal to 5% of critical damping and the value of $E = 200 \times 10^3$ MPa. Determine:

- (i) the natural circular frequency
- (ii) the frequency ratio, r
- (iii) the static deflection, V_o
- (iv) the steady state amplitude of vibration, given $V = D_s V_o$ where

$$D_s = \frac{1}{\sqrt{(1-r^2)^2 + (2\zeta r)^2}};$$

- (v) the maximum shear force in the column
- (vi) the maximum bending moment in the column

[8 marks]

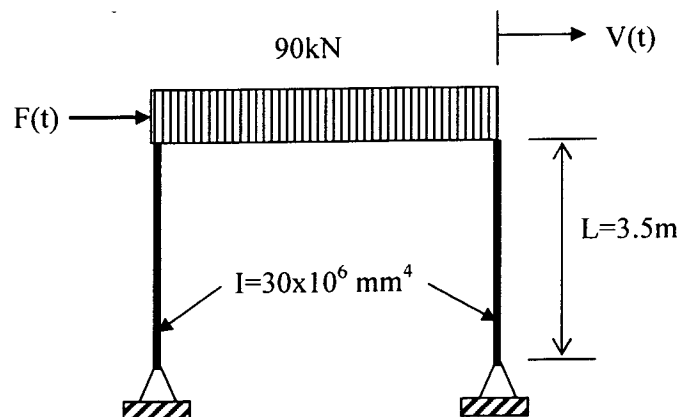

Figure 1

- (c) If frame in Figure 1 is subjected to sinusoidal ground motion $V_s(t)=5 \times 10^{-3} \cos 5.3t$ N is exerted instead of $F(t)$, on the girder. Assume the damping of the system is equal to 5% of critical damping and the value of $E = 200 \times 10^3$ MPa. Determine:

...3/-

(i) the maximum shear force in the column; given $u_{\max} = \frac{r^2 V_o}{\sqrt{(1-r^2) + (2\zeta r)^2}}$;

(ii) the maximum bending moment in the column

[6 marks]

2. (a) Define a response spectra in structural dynamic problems.

[4 marks]

(b) Figure 2(a) shows a model of column-mass SDOF system is subjected to two triangular blast loads, $p(t)$, as shown as Figure 2(b). The weight of the mass block is 2100 kN and the column stiffness, $k = 2000$ kN/mm. Assume it is an undamped system. Predict the maximum displacement response, $v_{\max} = R_{\max} \left(\frac{P_o}{K} \right)$ and the maximum total elastic forces developed in the system for both $p(t)$. The value of the maximum response ratio, R_{\max} can be obtained from the displacement response spectra as shown in Figure 2(c). Give comments on your observations of the results for both blast loads.

[6 marks]

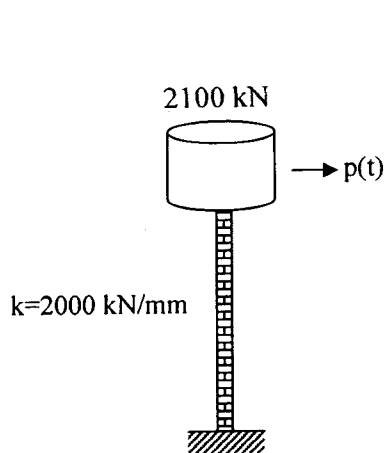

Figure 2(a)

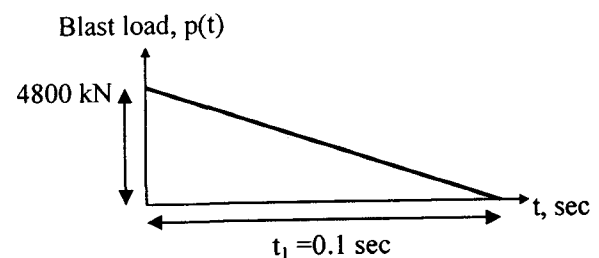
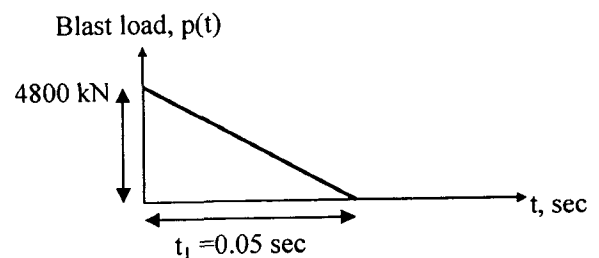

Figure 2(b)

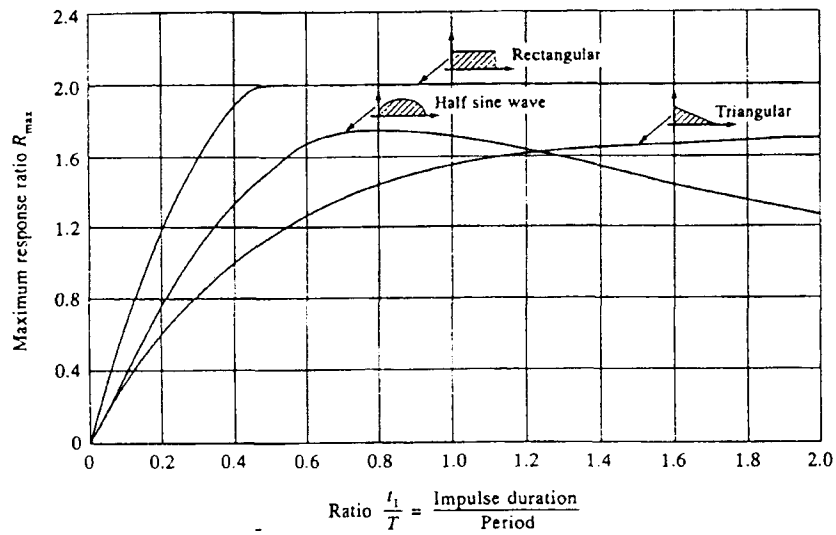

Figure 2(c)

- (c) Duhamel Integral is normally used for the evaluation of a linear SDOF system subjected to arbitrary time varying force. Define the underline term with the help of the graph Force, (P) versus (t).

[5 marks]

- (d) Figure 2(d) shows a spring-mass model for 2DOF system under free vibration. Derive the equations of motion for the system.

[5 marks]

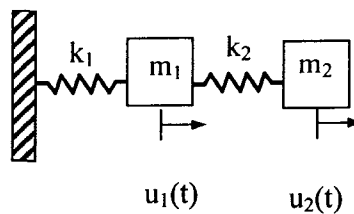

Figure 2(d)

3. (a) Explain the concepts of stable, unstable and neutral equilibrium with the aid of suitable sketches/diagrams.

[6 marks]

- (b) Figure 3 shows an initial straight column subjected to an axial load P which acts at an eccentricity e from the centroidal axis of the column. Obtain the following relation between mid-height deflection δ and ratio P/P_E where P_E : Euler buckling load $=\pi^2 EI/L^2$:

$$\delta = e \left[\sec \left(\frac{\pi}{2} \sqrt{\frac{P}{P_E}} \right) - 1 \right]$$

Sketch a plot of P/P_E versus δ for three different values of e .

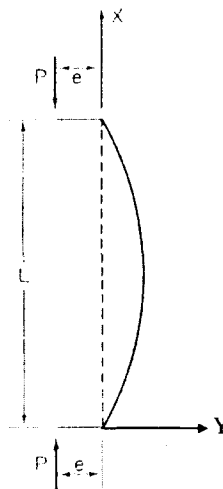

Figure 3

Sketch also on the same plot the graph representing the behaviour of an initially straight column with $e=0$. Indicate clearly the bifurcation point. Based on the graph, comment on the effect of imperfection of load on the behaviour of an axially loaded column.

[14 marks]

4. (a) Derive the following fourth order differential equation for beam-column :

$$y^{iv} + k^2 y'' = 0, \quad k^2 = \frac{P}{EI}$$

where y : lateral displacement of beam-column, P : axial force acting at both ends of beam-column, EI : flexural rigidity and $(\dots)' = d(\dots)/dx$. Next, derive the corresponding eigenvalue problem for a column with one end fixed and the other end pinned using the above fourth order differential equation. Solution of the eigenvalue problem is not required.

[10 marks]

- (b) A simple two-bar frame is shown in Fig.2 with fixed and pinned supports at A and C, respectively. A load P acts at end B of vertical member AB. Obtain the effective length L_e for the two-bar frame by using the following equation for an elastically restrained column :

$$(1 - \lambda_1 - \lambda_2 - \lambda_1 \lambda_2 \Phi^2) \Phi \sin \Phi + (2 + \lambda_1 \Phi^2 + \lambda_2 \Phi^2) \cos \Phi - 2 = 0$$

where $\lambda_1 = EI/(\alpha_1 L)$, $\lambda_2 = EI/(\alpha_2 L)$, $\Phi = kL$, $k^2 = P/EI$, EI : flexural rigidity of column, L : length of column, α_1, α_2 : rotational stiffness of end 1 and 2 of column being studied, respectively.

[10 marks]

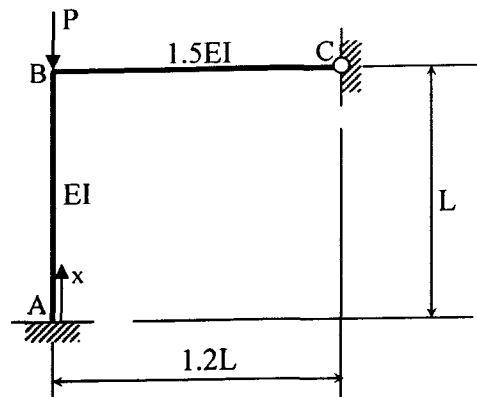

Figure 4

5. (a) Figure 5 shows a braced frames with the bottom ends of both columns pinned. Justify the following statement : $P_E < P_{cr} < 2.04P_E$, where P_E : Euler load, P_{cr} : critical load of the column in the frame of Figure 5.

[6 marks]

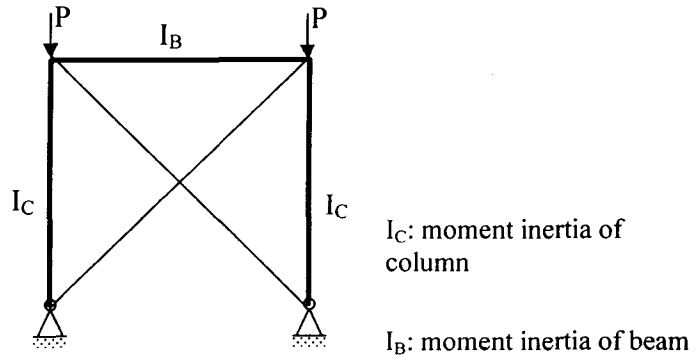

Figure 5

(b) Figure 5 shows a column fixed at one end and free at the other end. Section moment inertia of the column is $2I$ from A to B and I from B to C. The column is subjected to an axial load P at end C.

- (i) Evaluate the approximate critical load of the column using Rayleigh-Ritz method. Assume the slightly bent configuration of the column as $y = A_1x^2 + A_2x^3$.
- (ii) Analysis using Rayleigh-Ritz method has shown that the critical load of the column is $P_{cr} = 5EI/L^2$ when y is assumed as $y = A_1x^2$. Comment on the difference between this critical load with the one obtained in (i).

[14 marks]

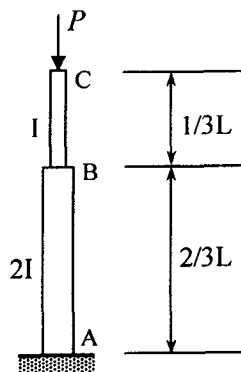

Figure 6