UNIVERSITI SAINS MALAYSIA

First Semester Examination
Academic Session 2008/2009

November 2008

EAS 661/4 – Advanced Structural Mechanics

Duration: 3 hours

Please check that this examination paper consists of **NINE (9)** pages of printed material before you begin the examination.

Instructions: Answer **ALL FIVE (5)** questions. All questions carry the same marks.

You may answer the question either in Bahasa Malaysia or English.

All questions **MUST BE** answered on a new sheet.

Write the answered question numbers on the cover sheet of the answer script.

1. (a) Figure 1 shows an infinitesimal volume in a three dimensional body under stressed condition. Derive the constitutive equation $\varepsilon = D\sigma$ for the case of a homogeneous isotropic body with modulus of elasticity E and Poisson's ratio ν where :

$$\sigma = [\sigma_x \ \sigma_y \ \sigma_z \ \sigma_{xy} \ \sigma_{yz} \ \sigma_{zx}]^T \quad \text{and} \quad \varepsilon = [\varepsilon_x \ \varepsilon_y \ \varepsilon_z \ \gamma_{xy} \ \gamma_{yz} \ \gamma_{zx}]^T$$

are the Cartesian components of stress and the corresponding strain.

[4 marks]

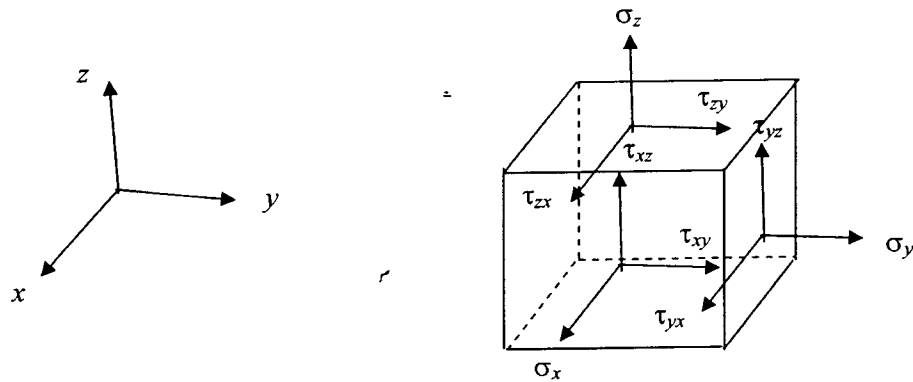

Figure 1

- (b) The set of equilibrium equations and strain-displacement equations for an infinitesimal volume in a three dimensional body as shown in Figure 1 are given as follows :

Equilibrium equations :

$$\frac{\partial \sigma_x}{\partial x} + \frac{\partial \tau_{xy}}{\partial y} + \frac{\partial \tau_{zx}}{\partial z} + R_x = 0$$

$$\frac{\partial \sigma_y}{\partial y} + \frac{\partial \tau_{yz}}{\partial z} + \frac{\partial \tau_{xy}}{\partial x} + R_y = 0$$

$$\frac{\partial \sigma_z}{\partial z} + \frac{\partial \tau_{zx}}{\partial x} + \frac{\partial \tau_{yz}}{\partial y} + R_z = 0$$

where R_x , R_y and R_z are body forces per unit volume in x , y and z -directions, respectively;

Strain-displacement equations :

$$\varepsilon_x = \frac{\partial u}{\partial x}, \quad \varepsilon_y = \frac{\partial v}{\partial y}, \quad \varepsilon_z = \frac{\partial w}{\partial z}$$

$$\gamma_{xy} = \frac{\partial u}{\partial y} + \frac{\partial v}{\partial x}, \quad \gamma_{yz} = \frac{\partial v}{\partial z} + \frac{\partial w}{\partial y}, \quad \gamma_{zx} = \frac{\partial w}{\partial x} + \frac{\partial u}{\partial z}$$

where u , v and w are components of displacement in x , y and z -directions, respectively, of a point within the three dimensional body.

Using the above sets of equations together with the general constitutive equations for a homogeneous isotropic body derived in (a) above, specialize them to the case of a prismatic bar under self-weight per unit length w as shown in Figure 2. Explain clearly all assumptions made in the process of specialization. State also the boundary conditions for the problem. Subsequently, derive the governing equation for the bar problem shown in Figure 2.

[8 marks]

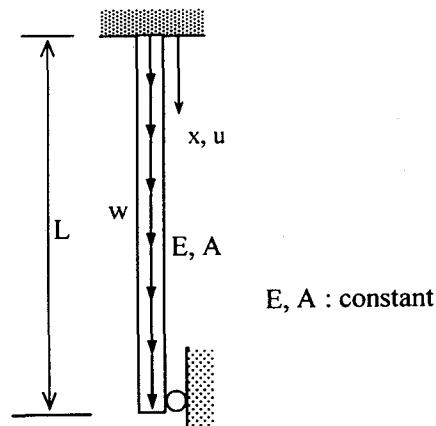

Figure 2

- (c) With the aid of appropriate sketch/diagrams, define a plane stress problem. Using the general constitutive equation obtained in (a) above, derive the constitutive equation for the case of a plane stress problem. Note that you are required to show clearly the coordinate system used.

[8 marks]

2. (a) Show that the statement of Principle of Virtual Displacement (PvD) can be specialized to the following equation:

$$\delta W_e = \delta U_p$$

for the case of a conservative problem where δW_e : variation in external work and δU_p : variation in strain energy.

With the use of the above statement of PvD for conservative problem, derive the equation of equilibrium for the linearly elastic spring shown in Figure 3 where k : spring constant, u : elongation of spring and F : force acting on the spring.

[8 marks]

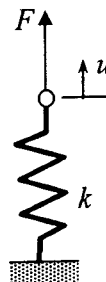

Figure 3

- (b) Figure 4 shows a simply supported beam with two elastic springs at C and D. The beam is subjected to a uniformly distributed load w . The following expression for lateral displacement field v has been suggested :

$$v = A \sin (\pi x / L)$$

where A is a constant. Show that the above displacement field is admissible. Next, solve for the constant A by applying the Principle of Minimum Potential Energy (PMPE). Flexural rigidity of beam is EI and spring constant for elastic spring is k .

[12 marks]

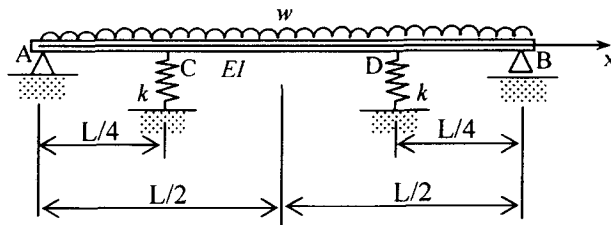

Figure 4

3. (a) The three basic relations that a structural mechanics problem must satisfy in order that exact solution is obtained are equilibrium, strain-displacement, and constitutive relations. Write down the three basic relations for the case of a simple 1D linearly elastic prismatic bar as shown in Figure 5. Subsequently, derive the following stiffness relation for the bar :

$$P = \frac{EA}{L} \Delta$$

where, Δ : elongation of bar due to force P , E : elastic modulus of material of bar, A : cross-sectional area, and L : original length of bar.

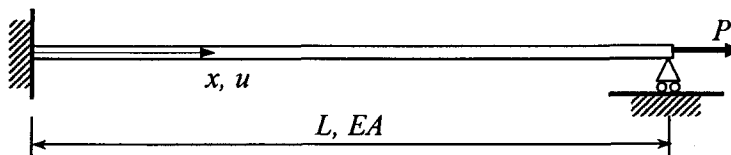

Figure 5

[4 marks]

- (b) The stepped beam with both end fixed as shown in Fig.6 is to be analysed using piecewise Rayleigh-Ritz method where the beam will be divided artificially into two portions <A-B> and <B-C>. The beam is subjected to a uniformly distributed load w and a point load P at B.

Illustrate clearly the process involved in solving the beam problem in order to obtain the lateral displacement v , distributions of shear force S and bending moment M along the beam. In the illustration, it is required to show the equations/relations used in the solution process. Solutions of v , S , and M are not required.

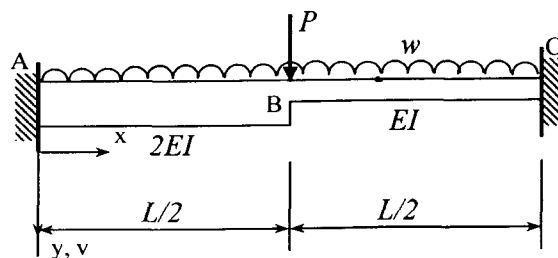

Figure 6

[16 marks]

4. (a) Write down the element stiffness matrices and global matrix for the **THREE (3)** bars assembly which is loaded with force P , and constrained at the two ends in terms of E , A and L as shown in Figure 7(a).

[5 marks]

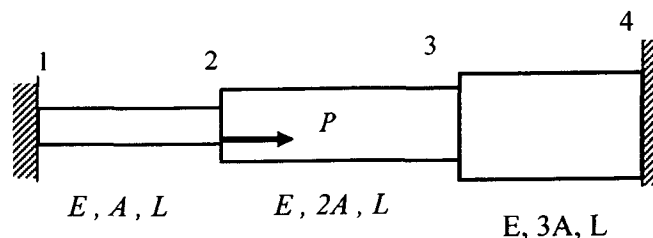

Figure 7(a)

- (b) Define the difference between a bar and beam in the analysis using Finite Element Method.

[5 marks]

(c) Figure 7(b) shows a system of two beams labeled as node 1, 2 and 3 and a spring labeled as node 3 and 4 subjected to a nodal forces of $P = 50$ kN at node 3. The beam is fixed at node 1, simply supported at node 2 and spring support at node 3. The spring system can only displace in axial direction and is supported at node 4. Given the value of $k = 200$ kN/m, $L_1 = L_2 = 3$ m, $E = 210$ GPa and $I = 2 \times 10^{-4}$ m⁴.

- Obtain the element stiffness matrix for the beam and the spring.
- Derive the global stiffness matrix for the system.
- Evaluate the deflection v_3 , θ_2 , and θ_3 in terms of metre and rad respectively.

[10 marks]

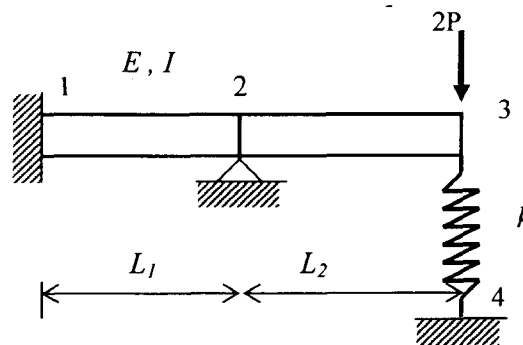

Figure 7(b)

Given the stiffness of the beam element in dimensional space:

$$k = \frac{EI}{L^3} \begin{bmatrix} v_i & \theta_i & v_j & \theta_j \\ 12 & 6L & -12 & 6L \\ 6L & 4L^2 & -6L & 2L^2 \\ -12 & -6L & 12 & -6L \\ 6L & 2L^2 & -6L & 4L^2 \end{bmatrix} \text{ for the beam element}$$

$$k = \begin{bmatrix} u_i & u_j \\ k & -k \\ -k & k \end{bmatrix} \text{ for the spring element}$$

5. (a) Explain what are the assumptions made in the modeling procedures for materials properties and loading conditions in Finite Element Method.

[5 marks]

- (b) A plate with a hole is subjected to tension, $p = 25.0\text{N/mm}^2$ as shown in Figure 8. It is a 2D plane stress problem. The plate is modeled with linear four-noded rectangular elements and three-noded triangular elements. Given Elastic Modulus $E = 7.0 \times 10^4 \text{N/mm}^2$, thickness, $t = 1\text{mm}$ and Poisson ratio, $\nu = 0.25$.

- (i) Explain and perform simplification through symmetry in modeling the plate using Finite Element Analysis.
- (ii) State the boundary conditions that apply to the model in i).
- (iii) Sketch a suitable meshing for the model with rectangular and triangular element.
- (iv) Sketch the stress in z direction near the hole.
- (v) Label point of maximum tension and maximum deflection.

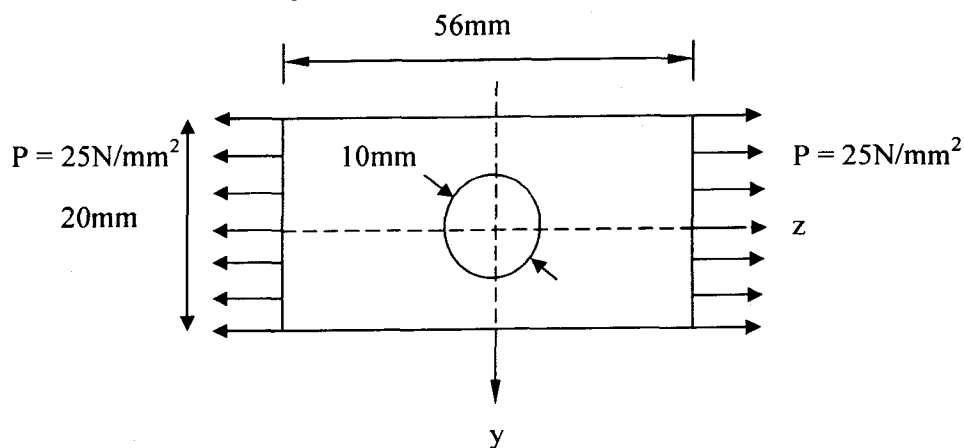

Figure 8

[10 marks]

- (c) What will happen to the value of maximum stress and maximum displacement in z direction if the problem in b(v) is assumed as plane strain instead of plane stress problem?

[5 marks]

6. (a) Define the difference between a triangular and rectangular finite element in plane elasticity.

[5 marks]

- (b) Show clearly in a step by step manner the development process of a stiffness matrix, $[K]^e$, for a triangular element in a state of plane stress as shown in Figure 9. Given $E = 200\text{GN/m}^2$, $\nu = 0.3$ and $t = 1\text{cm}$.

[15 marks]

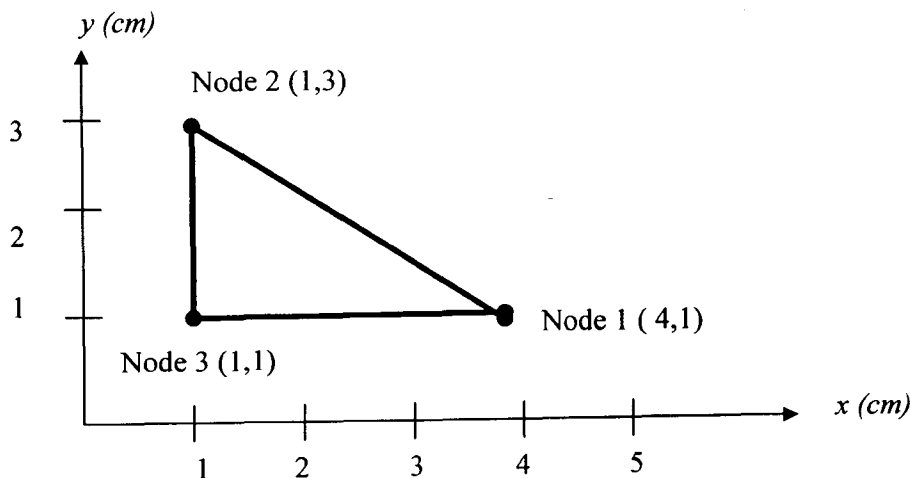

Figure 9