

CO₂ EMISSION AND CARBON CAPTURE FOR COAL FIRED POWER PLANTS IN MALAYSIA AND INDONESIA

MARTUNUS^{a,b}, M.R. OTHMAN^a, R. ZAKARIA^a, W.J.N. FERNANDO^a

^aSchool of Chemical Engineering, Universiti Sains Malaysia
14300 Nibong Tebal, Penang, Malaysia

^bDepartment of Chemical Engineering, Riau University
Pekanbaru 28293, Indonesia
Email:martunusche@yahoo.co.id

ABSTRACT

Coal consumption in Malaysia and Indonesia is growing at the rate of 9.7 and 4.7% per year since 2002, respectively. The increase in coal utilization usually tallies fairly well with the increase in CO₂ emission. The present study attempts at predicting the emissions of CO₂ from coal fired power plants from 2005 until 2020. The paper also analyzes the potential of carbon capture (CC) program as a source of foreign direct investment in Malaysia and Indonesia. The perceived emission rate is based on the percentage of coal for energy mix and coal consumption for electricity generation. Results from the study shows that CO₂ emission from coal fired power plants will grow at 4.1% per year to reach 98 million tons in Malaysia and 171 million tons in Indonesia by 2020. It is learnt that adsorption technology can be applied in coal fired power plants to reduce CO₂ emissions in Malaysia and Indonesia. Integrated Gasification Combined Cycle (IGCC) power plants incorporating a pre-combustion capture with the adsorption technology is one of the available options for new plants in Malaysia and Indonesia.

Keywords: Malaysia; Indonesia; Coal fired plant; Carbon capture.

INTRODUCTION

In 1896, a Swedish chemist, Svante Arrhenius put forth the idea that carbon dioxide (CO₂) emissions from combustion of coal could enhance the greenhouse effect and lead to global warming [1-2]. Now, the contribution of CO₂ towards global warming has been well known and taken as a fact. In Malaysia and Indonesia, the highest contributor to the emission of the gas reportedly came primarily from the energy sector [3-5]. Malaysia and Indonesia contributed 161.92 and 595.6 million tons of CO₂, respectively, last year.

In Malaysia, coal consumption for electricity generation grows at a rate of 9.7% per year, and is expected to increase substantially to meet the rising demand for energy. The electricity demand will increase by 4.7% per year. The growth in electricity demand is heavily influenced by strong demand from the industrial sector, which increases at 5.4% annually. Electricity demand for the residential sector will also experience strong growth of 4.9% per year. Per capita electricity demand is projected to be more than double from 2002 to reach 7,571 kWh/person in 2030. In Indonesia, coal consumption grows at 4.7% per year. Electricity demand grows annually at 4.6% to reach 108 GW in 2030 [6].

Considering the ever increasing demand for coal fired electricity, it would be interesting to understand and analyze the pattern of CO₂ emissions from the two countries. Thus, this study is carried out in order to predict the emissions of CO₂ from coal fired plants from 2005 to 2020, by correlating the percentage of coal for energy mix and coal consumption for electricity generation. The study also reviews some of the available technologies for carbon capture for new coal fired power plants in Malaysia and Indonesia.

SURVEY DATA

The data used for this study are the percentage of coal for energy mix data, coal consumption for electricity generation data and emissions of CO₂. These data are collected from various researches reported in the past and present [6-11].

Methodology. This study uses the scenario approach for the analysis. Schwartz [12] states that scenarios are tools for ordering perceptions about alternative future environments. Although the end result might not be an accurate picture of tomorrow, it can be utterly useful for making decision about the future. No matter how things might actually turn out, both the analyst and the policy maker will have a scenario that resembles a given future and that will help one think through both the opportunities and the consequences of that future.

This analysis is based on the pattern of coal consumption for electricity generation. Some of the data are readily available but other unavailabe data have to be calculated with respect to the countries electricity consumption trend. All the computation is performed using curve fitting toolbox (cftool) of Matlab[®] R2008a.

RESULTS AND DISCUSSION

In 2008, the total coal consumption for electricity generation in Malaysia is 21.15 million tons calculated based on 7 power plants, with 8120 MW installed capacity. Figure 1 shows the consumption of coal from 2005 to 2020 increases from 12.4 to 36 million tons.

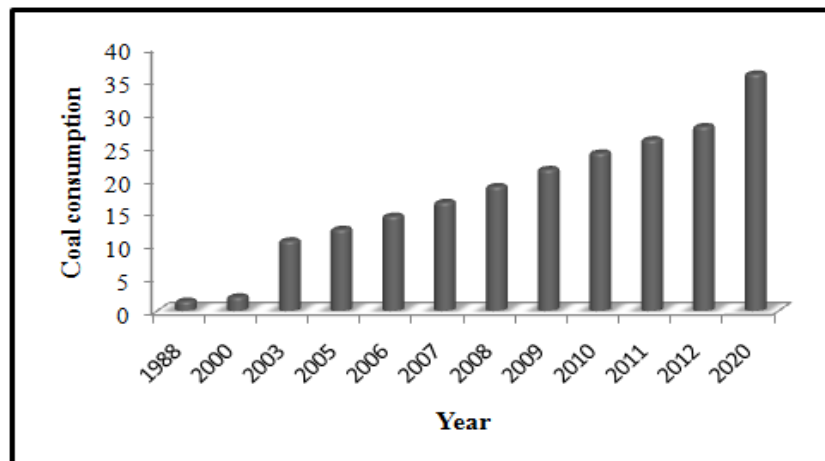

Figure 1: Coal Consumption for Electricity Generation in Malaysia (Million tons)

The increase in coal consumption has contributed to the changes in CO₂ emissions pattern in Malaysia. As a direct consequence, the total CO₂ emissions from coal fired power plants will reach 98 million tons by 2020, a two point sixty five-fold increase from 2005 as shown in Figure 2. The emission will continuously increase with the construction of new coal fired power plants and the increase on the capacity of existing coal fired power plants.

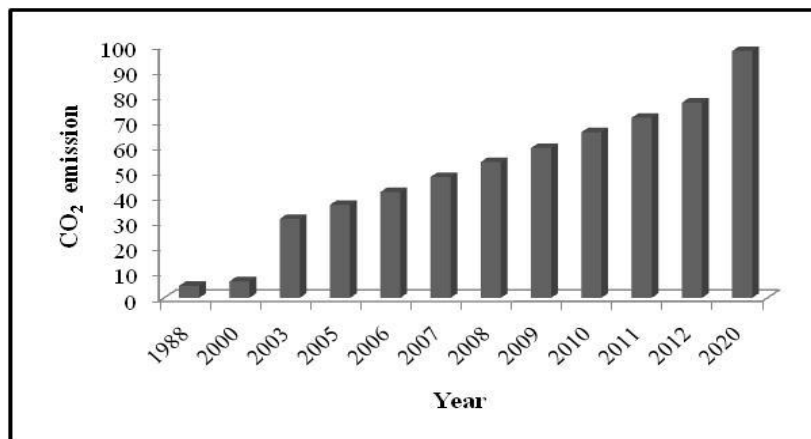

Figure 2: CO₂ Emissions from Coal Fired Plant in Malaysia (Million tons)

In Indonesia, the consumption of coal for electricity generation is 39.7 million tons (computed based on 25 power plants in 2008, with 11376 MW installed capacity). Figure 3 shows that the total consumption of coal from 2005 to 2020 grows from slightly over 12 to about 75 million tons.

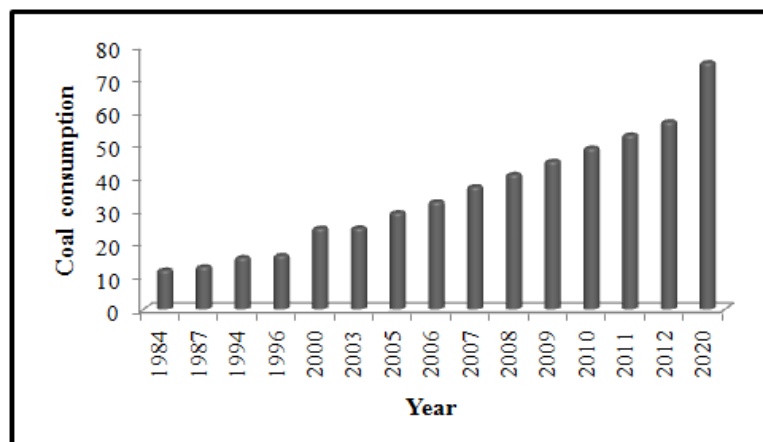

Figure 3: Coal Consumption for Electricity Generation in Indonesia (Million tons)

The total CO₂ emissions from coal fired power plants in Indonesia is expected to increase from 69.4 million tons in 2005 to 171 million tons in 2020 such as as shown in Figure 4. Similarly, this CO₂ emission will continuously increase with the construction of new coal fired power plants and the increase on the capacity of existing coal fired power plants in Indonesia.

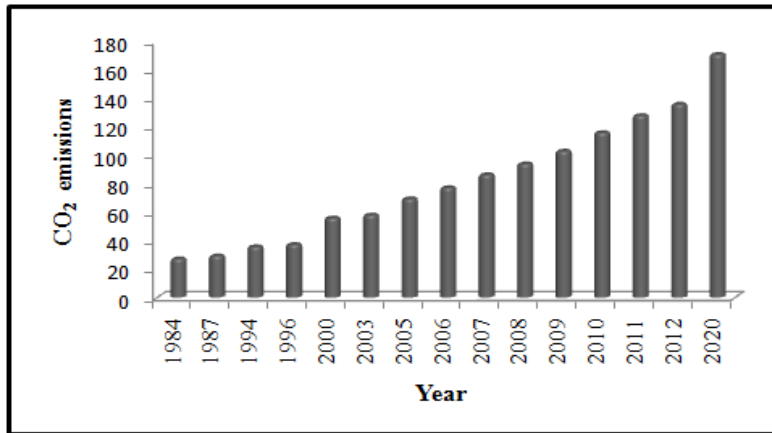

Figure 4: CO₂ Emissions from Coal Fired Plant in Indonesia (Million tons)

Carbon Capture and Storage. There are three alternatives to reducing CO₂ emissions without hampering economic growth. One is to use energy more efficiently, thereby reducing the energy consumption. The second option is to employ renewable energy sources that do not emit CO₂. The third option is to burn fossil fuels while capturing and storing the CO₂ instead of releasing it into the atmosphere. The option of burning fossil fuels while storing the CO₂ instead of releasing it is referred to as “CO₂ capture and storage (CCS)”, “Carbon capture and storage (CCS)” or “CO₂ sequestration”. CCS involves three distinct processes: (i) capturing CO₂ from the gas streams; (ii) transporting the captured CO₂; and (iii) storing CO₂ in geological formation [13-15].

The capture and storage of CO₂ presents one of the promising options for large-scale reductions in CO₂ emissions and is considered as competitive with other future carbon mitigation options. The cost to reduce CO₂ emissions from CCS technology is 2.5 €/kWh as shown in Table 1.

Table 1: Cost of CO₂ Emissions Reduction [16]

Cost of CCS	3 US\$/kWh (2.5 €/kWh)
Current buy-out price for UK renewables	over 5 €/kWh
Premium for wind power under the German Renewable Energy Law	9 €/kWh

CO₂ Capture. CO₂ capture systems refer to the integration of CO₂ capture in pre-combustion capture routes with the best suited capture technologies (i.e. absorption, adsorption, membranes and cryogenics) to mitigate CO₂ emissions from coal-fired power plants. The most demanding part of this approach is the capture and separation of CO₂ from other exhaust gas components. There are three main routes to CO₂ capture from combustion processes as shown in Figure 5 [17-20]:

- (i) *Post-combustion capture*, where the CO₂ in the exhaust gas coming from a standard gas turbine combined cycle, or a coal-fired steam power plant is captured through the use of chemical or physical solvents [17, 20-21].
- (ii) *Oxy-fuel combustion*, using concentrated oxygen rather than air for combustion has the advantage of increasing the CO₂ concentration in the flue gas (>80%), eliminating the need for expensive downstream separation equipment. Oxygen can be supplied from cryogenic air separation and fed to either a boiler or a gas turbine. In order to avoid high flame temperatures, the CO₂-rich flue gas is often recycled to make the flame

temperature similar to a normal air blown combustor. NO_x formation is also suppressed by using oxygen rather than air. The main disadvantage of oxy-fuel combustion is the large amount of O₂ required, which is energy consuming and expensive to produce [15].

- (iii) *Pre-combustion*, as the name indicates, captures CO₂ before the combustor by separating it from a synthesis gas mixture (H₂/CO). The fossil fuel is mainly converted to CO and H₂ by gasification, partial oxidation or reforming. CO is reacted with steam and catalytically converted to CO₂ and more H₂ in a water gas shift (WGS) step. CO₂ is then separated from hydrogen by chemical or physical absorption, membranes, cryogenic or pressure swing adsorption. The advantage of doing the separation before the combustor relates to the much higher partial pressure of CO₂ obtained compared to post-combustion, hence reducing the size of the equipment. This approach gives valuable hydrogen as product [20,22].

While post-combustion capture is considered practical, it requires large-scale equipment for the CO₂ removal, consumes process heat which leads to additional exhaust-gas pressure losses, causing the thermal efficiency to be significantly reduced [17-18, 21]. Post combustion is commercially available only on medium scale. At present, it is the most expensive in industrial application [23-24].

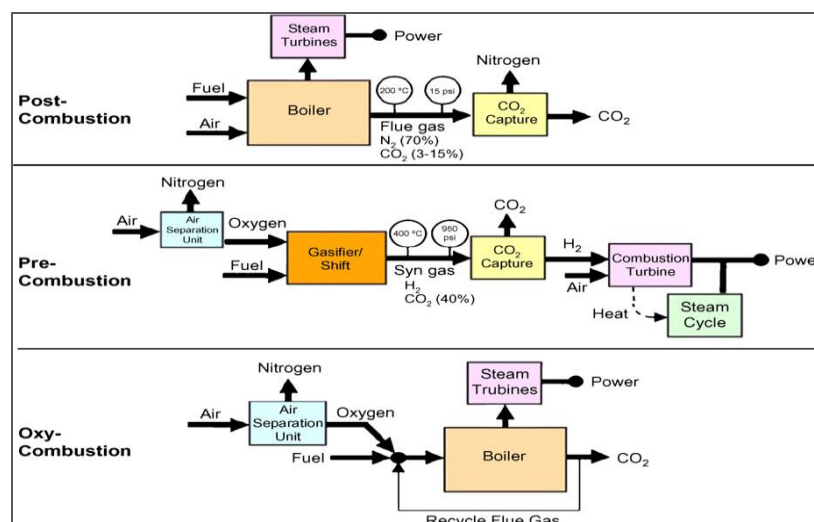

Figure 5: Schematic of Main CO₂ Capture Routes [20]

Choices of Coal Fired Power Plants. There are two types of coal fired power plants; pulverised coal (PC) and IGCC fired plants. IGCC power plants applying pre-combustion capture are more efficient than PC fired plants and would be an attractive choice for new plants [24]. Net efficiency for IGCC in existing plants is around 40 to 43% (LHV) and 38 to 41% (HHV). Recent gas turbines would enable this to be improved, and future developments should take efficiencies beyond 50% [25].

Unlike the ordinary coal-fired power plants, IGCC does not need to deal with low concentration pollutants in a large volume of flue gas. In a coal IGCC system, the gas coming out of the gasifier (syngas) is under high pressure and contains higher concentrations of pollutants than the exhaust gas of coal combustion does. Therefore, the cost of removing pollutants is comparatively lower [26]. Table 6 lays out the key technical and economic parameters for these two plants types with carbon capture. This comparison is based on total

capital, fuel, operating and CC costs for a hypothetical power plant with 500MW capacity operating at a factor of 80%.

Table 2: Comparison of Costs and Performance for a PC Plant and an IGCC Plant^a
[27]

Plant type	Capital costs (USD million)	Net heat rate (Btu/kWh)	Fuel input (million MMBtu)	Fuel costs ^b (USD million)	O&M costs ^c (USD million)	CO ₂ emissions (ton/MWh)	CO ₂ emissions (million tons/year)
IGCC	987	10,059	35.2	52.9	51.0	0.089	0.31
PC	1,258	12,193	42.7	64.1	62.1	0.108	0.38

a-capacity 500MW; capacity factor 80%; discount rate 6%.

b-assume a coal price of USD1.5/MMBtu

c-O&M costs with CO₂ capture include transportation and storage of captured CO₂ at USD 5/ton.

Capture Technologies. There are four main capture technologies namely absorption, adsorption, membranes and cryogenic separation. Cryogenic separation (low temperature distillation) requires much energy, thus expensive. Separation by membranes is attractive (a principle similar to filtration) but most membranes are under development and do not yet exist for an industrial scale [28].

In the end, only absorption and adsorption technologies appear suitable for large power plants. Absorption is considered as a proven technology to capture GHGs, and has been widely used in industry and widespread application in many different sectors. The mechanism of this technology in separating CO₂ is by employing solvents. The solvents work by either, reacting with the CO₂ and producing a chemical which is subsequently dissociated by heating to recover the solvents and CO₂ (i.e. chemical absorption), or by physically absorbing the CO₂ under the pressure and recovering the solvent and CO₂ by subsequently dropping the pressure (i.e. physical absorption). A typical absorption process utilizing monoethanolamine (MEA) is shown in Figure 6a.

On the other hand, adsorption (physical adsorption) process is based on the same principle but using porous solid adsorbents such as zeolites and activated carbon, and chemical reactions between adsorbent and CO₂ may or may not occur during the separation process [24]. Figure 6b shows a typical adsorption process.

An adsorption process consists of two major steps: adsorption and desorption. The technical feasibility of a process is dictated by the adsorption step, whereas the desorption step controls its economic viability. Strong affinity of an adsorbent for removing the undesired component from a gas mixture is essential for an effective adsorption step. The stronger the affinity, however, the more difficult it is to desorb the gas impurity and the higher the energy consumed in regenerating the adsorbent for reuse in the next cycle. The desorption step, therefore, has to be very carefully balanced against the adsorption step for an adsorption step to be successful [31-32].

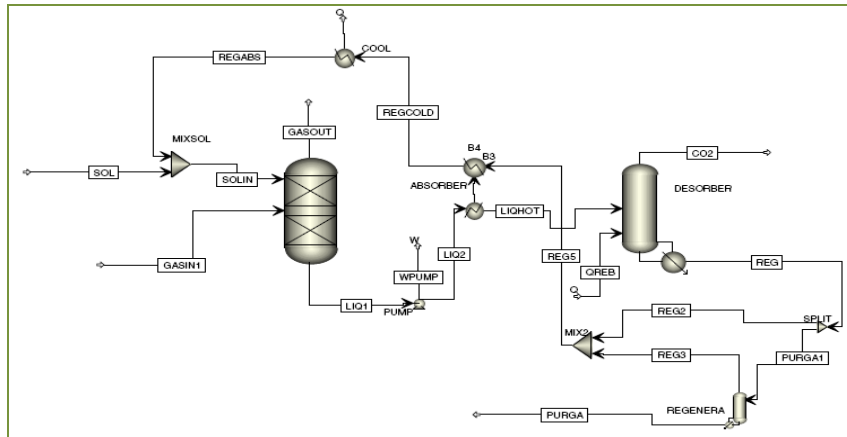

(a) MEA Absorption Process flowsheet [29].

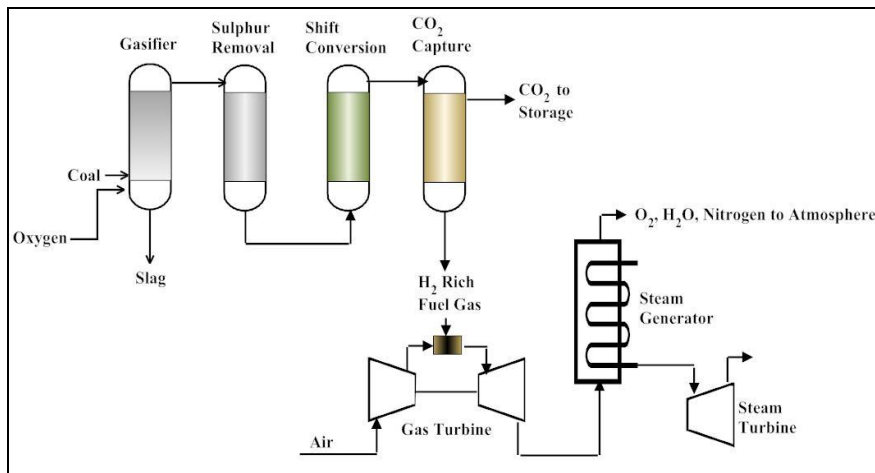

(b) An Adsorption Process Flowsheet [30]

Figure 6: A Coal Fired Power Plant Project Process Flowsheet.

The main advantage of physical adsorption over chemical or physical absorption is its simple and energy efficient operation and regeneration, which can be achieved with a pressure swing [31-34]. The appropriate operating condition for each capture technology is presented in Table 3. It is crucial that they are applied in compatible operating condition in order to reduce the cost such as shown in Table 4 and 5.

Table 3: Operating Condition [34]

Capture technologies	Gas flow ^a	CO ₂ partial pressure ^b	CO ₂ concentration ^c
MEA absorption	High	Low	Low
Adsorption	Low	High	High

a-A high gas flow is considered over 150 m³/s

b-A high CO₂ partial pressure is considered over 7 bar

c-A high CO₂ concentration is considered over 15% volume dry.

Table 4: Cost of Reduction Capture Technologies^a [35]

Capture technologies	Capital cost (million won/MW)	Fixed O & M (thousand won/MW)
MEA Absorption	736	29,425
Adsorption	702	28,087

a-1 US \$ = 1200 won

Table 5: Efficiency and CO₂ Emission Reduction [32]

Power plants	Efficiency penalty (% points)	Emission rate of CO ₂ (gCO ₂ /kWh)	CO ₂ emission reduction (%)
IGCC plus MEA chemical absorption	11	199	75
IGCC plus PSA adsorption	15	61	92

a-Based on lower heating value (LHV)

CONCLUSION

CC installation to accommodate large-scale CO₂ mitigation projects to reduce CO₂ emissions without hampering economic growth should be incorporated in all coal fired power plants. This is to prepare Malaysia and Indonesia to conform to the emission standards promulgated in the Kyoto Protocol in the future and reap the benefit from carbon trading along the process.

ACKNOWLEDGEMENTS

Funding for this work was provided by E-science Fund from MOSTI, Malaysia.

REFERENCES

- [1] McGinness, S., Climate change & the Kyoto Protocol. Science and Environment Section, House of Commons Library, 2001. Available at: <<http://www.parliament.uk>>.
- [2] Yantovski, E., J. Gorski, B. Smyth, J. ten Elshof, Zero-emission fuel-fired power plants with ion transport membrane, *Energy*, Vol. 29, 2004, pp. 2077-2088.
- [3] World Bank, The little green data book, 2007. Available at: <<http://www.worldbank.com>> (Access on 3 March 2008).
- [4] PTM (Pusat Tenaga Malaysia), Energy smart special focus: mitigating the adverse impact of climate change through sustainable use of energy, 2008. Available at: <<http://www.ptm.org.my>> (Access on 12 March 2008).
- [5] PEACE (Pelangi Energy Abadi Citra Enviro), Indonesia and climate change: Current status and policies, 2007. Available at: <<http://www.peace.co.id>> (Access on 3 March 2008).
- [6] APERC (Asia Pacific Energy Research Centre), APEC energy demand and supply outlook 2006. Tokyo, 2006.
- [7] Mahmud, O.H., TNB Fuel. The 15th JAPAC International Symposium, Tokyo, September 19, 2003.
- [8] Suruhanjaya Tenaga, Statistics of electricity supply industry in Malaysia, 2005. Available at: <<http://www.st.gov.my>> (Access on 24 March 2008).
- [9] Chiew, H., Tenaga nasional berhad's (TNB) assurance that its coal-fired power plant in Lahad Datu will employ clean coal technologies does little to allay local's fears of

- adverse effects on the area, 2008. Available at: <<http://www.climateark.org/shared/reader/welcome.aspx?linkid=92802>> (Access on 12 April 2008).
- [10] Suyartono, Indonesian coal utilization and its environmental issues, Director of Mineral and Coal Technique, Department Energy and Mineral Resources, Republic of Indonesia, 2008.
- [11] Utami, N.S., Coal policy in Indonesia. Center for Energy Information Ministry of Energy and Mineral Resources Indonesia, 2007.
- [12] Schwartz, P., *The art of the long view: planning in an uncertain world*, New York, Doubleday, 1996.
- [13] IPCC (Intergovernmental Panel on Climate Change), Carbon dioxide capture and storage: Summary for policymakers and technical summary. Reports of Working Group III of the IPCC, IPCC, UNFCCC, Bilthoven, Netherland, 2006.
- [14] UNFCCC, Indonesia: the first national communication on climate change convention, 2008. Available at: <<http://www.unfccc.int>> (Access on 6 April 2008).
- [15] Thambimuthu, K., J. Davidson, Overview of CO₂ capture. 7th International Conference on Greenhouse Gas Control Technologies, Vancouver, Canada, 2004.
- [16] WCI, Coal and the environmental challenge the role of clean coal technologies, 2008. Available at: <<http://www.worldcoal.org>> (Access on 7 April 2008).
- [17] WCI (World Coal Institute), Technology to reduce greenhouse gas emissions on meeting global challenges, 2007. Available at: <<http://www.worldcoal.org>> (Access on 7 April 2008).
- [18] Audus, H., An update on CCS: recent developments. Paper presented at 2nd IEA workshop on legal aspect of storing CO₂, Paris, France, October 17, 2006.
- [19] Stromberg, L., Pilot project update-focus an european projects, Issues in *Carbon Capture Journal*, Vol. 2, 2008, p. 14.
- [20] Figueroa, J.D., T. Fout, S. Plasynski, H. McIlvried, R.D. Srivastava, Techno-economic study of CO₂ capture from natural gas based hydrogen plants, *International Journal of Greenhouse Gas Control*, Vol. 2, 2008, pp. 9-20.
- [21] Bredesen, R., K. Jordal, O. Bolland, High-temperature membranes in power generation with CO₂ capture, *Chemical Engineering and Processing*, Vol. 43, 2004, pp. 1129-1158.
- [22] Metz, B., O. Davidson, H. de Connick, M. Loos, L. Meyer, Special report on carbon dioxide capture and storage, Cambridge University Press, 2005.
- [23] Stromberg, L., Pilot project update-focus an european projects, Issues in *Carbon Capture Journal*, Vol. 2, 2008, p. 14.
- [24] Yang, H., Z. Xu, M. Fan, R. Gupta, R.B. Slimane, A.E. Bland, I. Wright, Progress in carbon separation and capture: a rievew, *Journal of Environmental Sciences*, Vol. 20, 2008, pp. 14-27.
- [25] Henderson, C., G8 case studies by the IEA clean coal centre. In: Conference: clean coal technologies for our future, London, 15-17 May, 2007.
- [26] Liu, H., W. Ni, Z. Li, L. Ma, Strategic thinking on IGCC development in China, *Energy Policy*, Vol. 36, 2008, pp. 1-11.
- [27] Sekar, R.C., J.E. Parsons, H.J. Herzog, H.D. Jacoby, Future carbon regulations and current investments in alternative coal-fired power plant technologies, *Energy Policy*, Vol. 35, 2007, pp. 1064-1074.
- [28] Kanniche, M., C. Bouallou, CO₂ capture study in advanced integrated gasification combined cycle, *Applied Thermal Engineering*, Vol. 27, 2007, pp. 2693-2702.
- [29] Romeo, L.M., I. Bolea, J.M. Escosa, Integration of power plant and amine scrubbing to reduce CO₂ capture costs, *Applied Thermal Engineering*, Vol. 28, 2008, pp. 1039-1046.

- [30] Delphi (The Delphi Group), ARC (Alberta Research Council), Building capacity for CO₂ capture and storage in the APEC region, Edmonton, Alberta, Canada, 2005.
- [31] Wong, S., R. Bioletti, Carbon dioxide separation technologies. Carbon & Energy Management Alberta Research Council, Edmonton, Alberta, T6N 1E4, Canada, 2002.
- [32] IEA GHG R&D Programme, Greenhouse gas releases from fossil fuel power stations. IEAGHG/SR1, IEA GHG, Cheltenham, UK, 1993.
- [33] Simbeck, D.R., CO₂ mitigation economics for existing coal-fired power plants. First National Conference on Carbon Sequestration, May 14-17, 2001.
- [34] IEA GHG R&D Programme, Permitting issues for CO₂ capture and geological storage. 3 January, IEA GHG, Cheltenham, UK, 2006.
- [35] Lee, S., J.W. Park, H.J. Song, S. Maken, T. Filburn, Implication of CO₂ capture technologies options in electricity generation in Korea, *Energy Policy*, Vol. 36, 2008, pp. 326-334.