UNIVERSITI SAINS MALAYSIA

Semester II Examination
Academic Session 2007/2008

April 2008

**EEE 521 – COMPUTER AND DATA COMMUNICATIONS
NETWORKS**

Time: 3 Hours

INSTRUCTION TO CANDIDATE:

Please ensure that this examination paper contains **NINE (9)** printed pages and **SIX (6)** questions before answering.

Answer **FIVE (5)** questions.

Distribution of marks for each question is stated accordingly.

All questions must be answered in English.

1. (a) Discuss the main functions of the following communication devices by highlighting the layer that they are associated with. Using an appropriate diagram, compare and contrast the collision and broadcast domains for each device.

- (i) Hub
- (ii) Repeater
- (iii) Bridge
- (iv) Router

(20 marks)

(b) Your organization has been assigned an IP network of 201.168.130.0. As a network engineer, you are to design your company's network with 6 departments having separate subnetworks.

- Management subnet – 30 hosts
- Engineering subnet – 20 hosts
- Sales subnet – 23 hosts

Suppose you are given 4 contiguous C class addresses. With a selection of an appropriate sets of C class addresses of your choice, develop a supernet solution to the above given problem. Be sure to identify each of supernet address, broadcast address, supernet masks and the range of valid IP addresses for each supernet.

(20 marks)

(c) Describe the typical use of the following TCP/IP tools

- (i) Ping
- (ii) Tracert
- (iii) Netstat
- (iv) IPConfig

(10 marks)

2. (a) Describe in details the type of Class A, B, C, D, and E addresses for classful addressing.

(10 marks)

(b) As a system administrator, you are to design and optimize the use of IP address in your organization. Assume that your organization has 100 computers to be divided equally within two departments, called Maintenance and Administration respectively. (Note: each department will have 50 computers).

- (i) Choose and justify the classful address that is the **most suitable** for your organization.
- (ii) Based on your answer in part b) i), suggest your own network address, and design an appropriate subnet for both departments. Be sure to also identify the subnet mask.
- (iii) Identify the range of usable IP addresses along with the broadcast address for each department.
- (iv) Draw the appropriate network connection along with the using several routers.

(30 marks)

...4/-

- (c) By suggesting real life applications, compare and contrast between the TCP and UDP protocols.
(10 marks)
3. (a) The TCP/IP internet model is divided into 5 layers.
- (i) Identify and describe the functionalities of each layer in details.
 - (ii) How does the layering model help in terms of simplifying network design and management
(20 marks)
- (b) Describe the main and the common Java libraries that can be used to utilize the TCP and UDP protocols.
(15 marks)
- (c) Using either TCP or UDP Java class libraries with other appropriate libraries, write a Java program to allow a message "Hello_World" to be sent from a sender program to a receiver program. Assume that the communication happens from localhost connections.
(15 marks)
4. (a) Describe in details the following terms:
- (i) TCP Handshake
 - (ii) TCP Termination Requests
 - (iii) TCP sliding window for flow control
(15 marks)

(b) Using an appropriate example, highlight the Silly Window Syndrome associated with TCP sliding window. How does the Nagle algorithm, and the Clark solution help to alleviate the Silly Window Syndrome.

(10 marks)

(c) Reconfigure the following network into 6 subnetworks. Draw the appropriate network diagram using several routers along with the connected hosts and their range of IP address assignments.

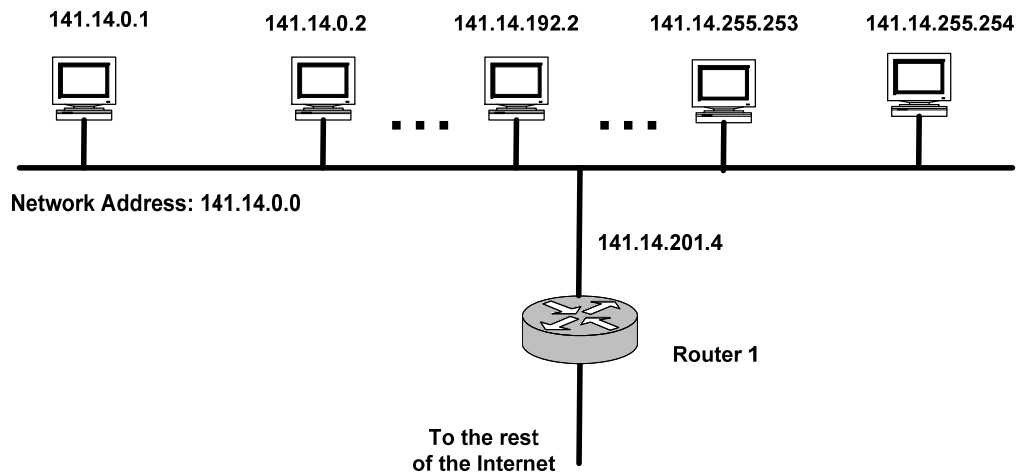

Figure 4(c): Network Diagram

(25 marks)

5. (a) Using appropriate diagrams, describe following terms:
- (i) The Computational Model for Distributed Shared Memory Implementation
 - (ii) The Computational Model for Remote Procedure Call
 - (iii) The Computational Model for traditional database application

Compare and contrast the three computational models by highlighting their main features as well as limitations along with possible examples of applications for each model.

(20 marks)

- (b) LINDA defines a number of operations for manipulating the distributed shared memory. Among the main operations are:
- in(tuple)
 - out(tuple)
 - read(tuple)
 - in_nb(tuple)

Describe each of the abovementioned operations.

(20 marks)

(c) Referring to the following excerpt of Java code:

```
tuple = new Tuple(new String("Mercedes"), new String ("RM150K"), new String ("1996"));
Object_Space.out (tuple);
Object_Space.out (tuple);
Object_Space.in (tuple);
Object_Space.read (tuple);
Object_Space.out (tuple);
Object_Space.out (tuple);
Object_Space.out (tuple);
Object_Space.read (tuple);
Object_Space.in (tuple);
Object_Space.in_nb (tuple);
tuple = new Tuple(new String("Serena"), new String ("RM136K"), new String ("2008"));
Object_Space.out (tuple);
```

Sequentially, trace the contents of the tuple space and the state of the program (i.e. whether blocking or non-blocking) for each out(tuple), in(tuple), read(tuple), and in_nb(tuple) operations.

(10 marks)

6. (a) Describe the following terms:

- (i) Carrier Sense Multiple Access (CSMA)
- (ii) ARP and RARP Protocol
- (iii) DHCP

(15 marks)

(b) Given the following diagrams of the spanning tree bridge network, determine which bridges would be used in forwarding packets?

(i)

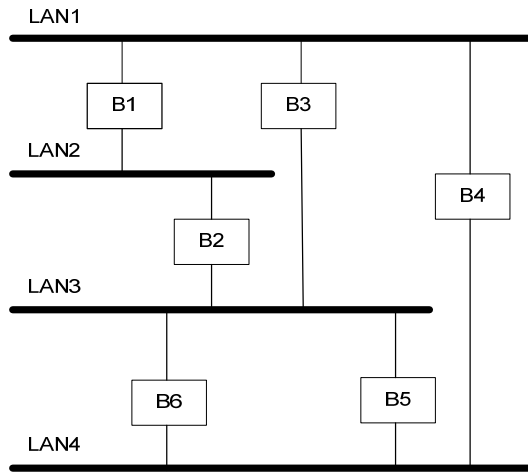

Figure 6 b) (i): Bridge Network

(ii)

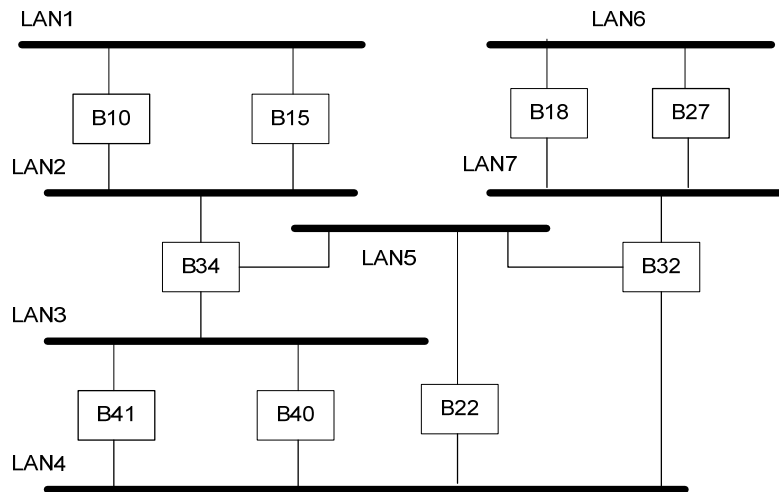

Figure 6 b) (ii): Bridge Network

(20 marks)

...9/-

- (c) Discuss the TELNET and FTP protocols. How can these protocols be employed in real life applications

(15 marks)

ooo0ooo