UNIVERSITI SAINS MALAYSIA

Peperiksaan Semester Pertama
Sidang Akademik 2007/2008

Oktober/November 2007

EEM 221 – PRINSIP DAN MEKANIK BAHAN

Masa : 3 Jam

Sila pastikan kertas peperiksaan ini mengandungi **SEBELAS** muka surat dan **EMPAT** muka surat LAMPIRAN bercetak sebelum anda memulakan peperiksaan ini.

Kertas soalan ini mengandungi **ENAM** soalan.

Jawab **LIMA (5)** soalan.

Mulakan jawapan anda untuk setiap soalan pada muka surat yang baru.

Agihan markah diberikan di sudut sebelah kanan soalan berkenaan.

Jawab semua soalan dalam Bahasa Malaysia atau Bahasa Inggeris.

1. (a) Aloi Aluminium-Lithium diperkenalkan oleh industri pesawat terbang untuk mengurangi berat dan meningkatkan prestasi pesawat terbang. Diketahui bahawa Aluminium mempunyai ketumpatan 2.71 g/cm³. Anda dikehendaki untuk merekabentuk bahan kulit pesawat komersial menggunakan aloi ini yang mempunyai ketumpatan 2.47 g/cm³.

Aluminum-Lithium alloys have been developed by the aircraft industry to reduce the weight and improve the performance of its aircrafts. It is known that the Aluminum density is 2.71 g/cm³. You are required to design a commercial aircraft skin material using this alloy which has a density of 2.47 g/cm³.

Berdasarkan persamaan-persamaan di bawah:

Based on by the following equations:

$$C_1 = \frac{m_1}{m_1 + m_2} \times 100$$

$$C'_1 = \frac{n_{m1}}{n_{m1} + n_{m2}} \times 100$$

laitu

Where

C_1 is the concentration of 1 in wt%

m_1 and m_2 are the mass of elements 1 and 2

C'_1 is the concentration of 1 in at%

n_{m1} and n_{m2} are the number of moles of element 1 and 2

- (i) Terbitkan formula untuk menukar dari peratusan berat kepada peratusan atom.

Derive the formula to convert from weight percentage to atom percentage.

(25%)

...3/-

- (ii) Terbitkan formula untuk mengira ketumpatan aloi daripada peratusan berat.

Derive the formula to calculate alloy density from weight percentage.

(25%)

- (iii) Kira berat Li di dalam 5 kg aloi Al-Li ini. Ciri Aluminium dan Lithium diberikan di dalam Lampiran A.

Compute the weight of Li in 5 kg this Aluminum-lithium alloys. The characteristic of Aluminum and Lithium are given in Appendix A.

(20%)

- (b) Aloi Aluminium-Lithium ini mempunyai 50 mm x 50 mm keratan rentas segiempat sama dan panjangnya 3-m digunakan sebagai rasuk mudah di dalam sebuah kapal terbang. Kira lenturan maksima dan cerun maksima disebabkan seorang lelaki berdiri di tengah-tengah rasuk ini.

This Aluminum-lithium alloy with 50 mm × 50 mm square section, 3-m span is also used as a simple beam in an aircraft. Compute the maximum deflection and the maximum slope due to a man weighing 100 kg standing in the middle of the beam.

Anda boleh gunakan kaedah formula untuk menyelesaikan masalah ini dan Modulus Young bagi aloi ini ialah 69 GPa.

You can use formula method to solve this problem and Young Modulus for this alloy is 69 GPa.

(30%)

2. (a) Terangkan tentang kecacatan titik serta kecacatan titik bendasing yang wujud dalam pepejal. Lukiskan lakaran yang sesuai.

Explain the point defects and also impurity point defects which are found in solids. Draw suitable sketches.

(30%)

- (b) (i) Lakar satah (100) dan (111) di dalam satu kuib unit sel.

Sketch (100) and (111) planes within a cubic unit cell.

(10%)

- (ii) Kira nilai ketumpatan satah bagi satah (100) dan (111) bagi Besi.

Compute the planar density values for (100) and (111) planes of Iron.

(20%)

- (c) Tegangan regangan dikenakan kepada satu kristal tunggal Besi pada arah [001]. Sekiranya gelinciran berlaku pada satah (111) dan dalam arah $[\bar{1}01]$, dan ia dimulakan oleh satu tegangan regangan sebanyak 10 MPa, kira tegangan ricih peleraian kritikal.

A tensile stress is applied to a single crystal of Aluminum in a [001] direction. If the slip occurs on a (111) plane and in a $[\bar{1}01]$ direction, and it is initiated at an applied tensile stress of 10 MPa, compute the critical resolved shear stress.

(40%)

3. (a) Terangkan perbezaan antara kegagalan rapuh dan kegagalan kenyal.

Explain the differences between brittle failure and elastic failure.

(20%)

- (b) Satu menara perlu disokong oleh rangkaian wayar keluli. Dianggarkan bahawa beban pada setiap wayar ialah 14000 N. Tentukan garis pusat terkecil bagi wayar yang diperlukan. Anggap faktor keselamatan ialah 5 dan kekuatan alah ialah 860 MPa bagi keluli.

A tower is to be supported by a series of steel wires. It is estimated that the load on each wire will be 14000 N. Determine the minimum required wire diameter, assuming a safety factor of 5 and a yield strength of 860 MPa for the steel.

(40%)

- (c) Terangkan dengan bantuan gambarajah tentang pembentukan struktur mikro dalam aloi isomorphous berdasarkan:

Explain with the help of diagrams of the development of microstructure in isomorphous alloys based on:

(i) Penyejukan Keseimbangan
Equilibrium Cooling

(ii) Penyejukan Tak-Seimbang
Nonequilibrium Cooling

(20%)

Jelaskan perbezaan antara sifat kenyal dan plastik.

Describe the difference between elastic and plastic behaviour.

(20%)

4. (a) Di dalam kristal germanium konsentrasi kekosongan keseimbangan berkurang sebanyak 1 juta kali ganda apabila disejukkan dari suhu 600°C kepada 300°C. Diberikan berat atom germanium ialah 72.59 dan ketumpatannya ialah 5.32 g/cm³. Bilangan kekosongan keseimbangan diberikan oleh persamaan seperti di bawah.

In the germanium crystal the equilibrium vacancy concentration decreased by 1 million times when the temperature was reduced from 600°C to 300°C. Given, the atomic weight of germanium is 72.59 and its density is 5.32 g/cm³. The equilibrium number of vacancies is given in the following equation.

$$N_v = N \exp\left(-\frac{Q_v}{kT}\right)$$

- (i) Kirakan tenaga pembentukan kekosongan.

Calculate the energy of formation of the vacancy.

(20%)

- (ii) Kirakan bilangan kekosongan per sentimeter padu pada suhu 300°C.

Calculate the number of vacancies per cubic centimeter at temperature of 300°C.

(10%)

- (b) Menggunakan gambarajah fasa plumbum-timah dalam Rajah 4(a), jawab soalan-soalan berikut:

Using the lead-tin phase diagram in Figure 4(a), answer the following questions:

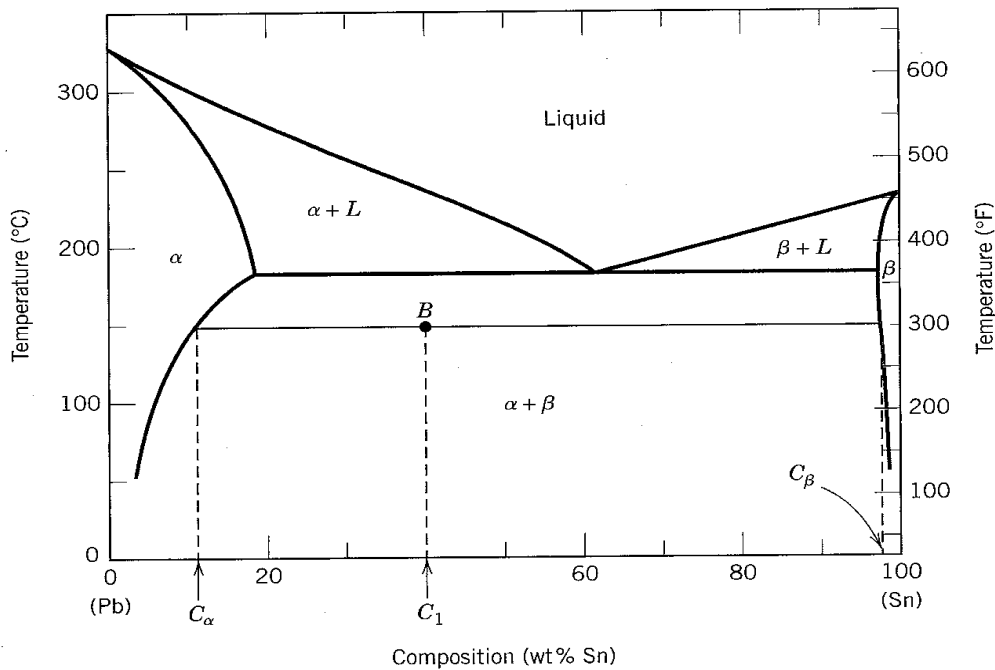

Rajah 4(a)
Figure 4(a)

Berdasarkan satu aloi 40 wt% Sn-60 wt% Pb pada 150°C (300°F):

Based on a 40 wt% Sn-60 wt% Pb alloy at 150°C (300°F):

- (i) Apakah fasa yang wujud?

What phase(s) is (are) present?

(10%)

- (ii) Apakah komposisi fasa-fasa ini?

What is (are) composition(s) of the phase(s)?

(10%)

...8/-

- (iii) Kira kuantiti relatif bagi setiap fasa dalam pecahan jisim.

Calculate the relative amount of each phase present in mass fraction.

(10%)

- (iv) Kira kuantiti relatif bagi setiap fasa dalam pecahan isipadu.

Calculate the relative amount of each phase present in volume fraction.

(20%)

Pada 150°C, ketumpatan Pb dan Sn ialah 11.23 dan 7.24 g/cm³.

At 150°C the densities of Pb and Sn are 11.23 and 7.24 g/cm³, respectively.

- (c) Lakarkan lenkungan S-N bagi

Sketches the S-N curves for:

- (i) Satu bahan yang menunjukkan had kelesuan.

A material displays a fatigue limit.

- (ii) Satu bahan yang tidak menunjukkan had kelesuan.

A material that does not display a fatigue limit.

(20%)

5. (a) Huraikan tentang tiga mekanisma penguatan. Jelaskan bagaimana kehelan terlibat dalam setiap mekanisma penguatan tersebut.

Describe three strengthening mechanisms. Explain on how dislocations are involved in each of the strengthening mechanisms.

(30%)

- (b) Tiga 50-mm × 100-mm papan keping diikat oleh 5-mm-diameter bolt yang mana jarak antara satu sama lain ialah 40 mm seperti ditunjukkan dalam Rajah 5(b). Tegasan ricih yang dibenarkan ialah 100 MPa.

Three 50-mm × 100-mm planks are fastened by 5-mm-diameter bolts spaced at a pitch of 40 mm as shown in Figure 5(b). The allowable shear stress for the bolts is 100 MPa.

- (i) Buktikan bahawa sebutan bagi daya ricih yang mesti ditanggung oleh bolt adalah seperti di bawah:-

Prove that the expression for the shear force that must be carried by the bolt is as follows:-

$$F_s = p \frac{VQ}{I}$$

iaitu
Where

p ialah jarak antara bolt

p is the pitch of the bolts

V ialah daya ricih pada bahagian itu

V is the shear force at the section

Q ialah moment pertama bagi kawasan terhadap paksi neutral

Q is the first moment of area about the neutral axis

I ialah momen inersia

I is the moment of inertia

(40%)

...10/-

- (ii) Tentukan beban tertumpu maksima yang boleh dikenakan pada titik tengah bagi 3-m rentang mudah. Abaikan berat rasuk tersebut.

Determine the maximum concentrated load that can be applied at the mid point of 3-m simple span. Neglect the weight of the beam.

(30%)

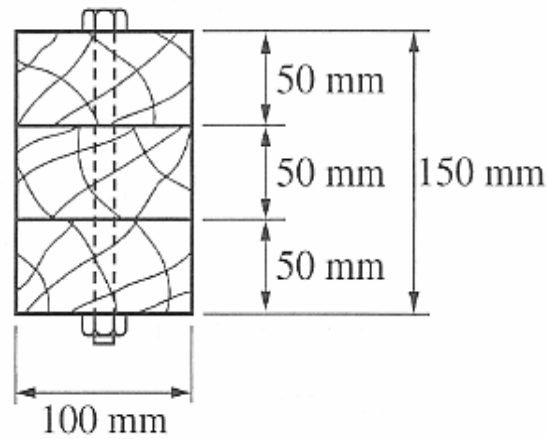

Rajah 5(b)
Figure 5(b)

- 6. (a) Rajah 6(a) menunjukkan tiga satah kristalografi yang berbeza bagi satu unit sel satu logam (**andaian**); bulatan mewakili atom:

*Figure 6(a) shown three different crystallographic planes for a unit cell of some **hypothetical** metal; the circle represents atoms:*

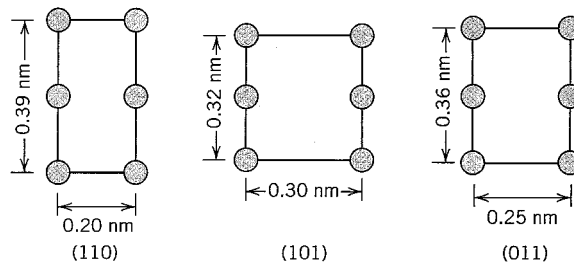

Rajah 6(a)
Figure 6(a)

(i) Apakah nama struktur kristal ini?
What would this crystal structure be called?

(ii) Sekiranya ketumpatan logam ini ialah 18.91 g/cm^3 , tentukan berat atom bagi logam ini.

If the density of this metal is 18.91 g/cm^3 , determine its atomic weight.

(30%)

(b) Lukiskan gambarajah daya ricih dan momen lenturan bagi rasuk yang terjantai seperti yang ditunjukkan dalam Rajah 6(b).

Draw the shear force and bending moment diagrams of the overhanging beam shown in Figure 6(b).

(40%)

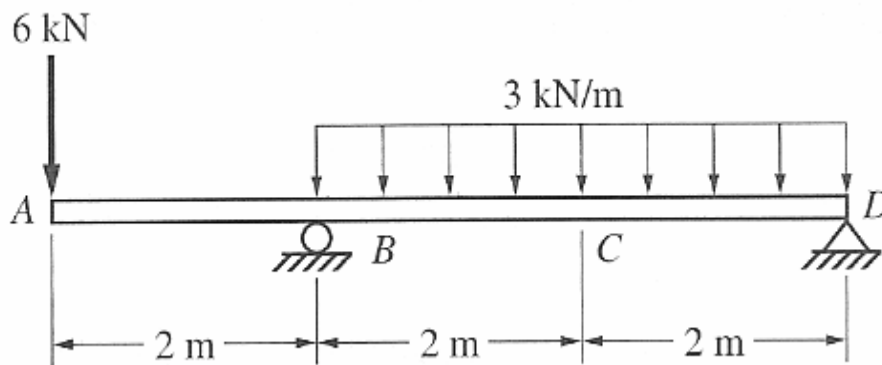

Rajah 6(b)
Figure 6(b)

(c) Terangkan hubungan antara beban, ricih dan momen. Lukis lakaran yang sesuai.

Explain the relationship between load, shear and moment. Draw suitable sketches.

(30%)

Characteristics of Selected Elements

<i>Element</i>	<i>Symbol</i>	<i>Atomic Number</i>	<i>Atomic Weight (amu)</i>	<i>Density of Solid, 20°C (g/cm³)</i>	<i>Crystal Structure, 20°C</i>	<i>Atomic Radius (nm)</i>	<i>Ionic Radius (nm)</i>	<i>Most Common Valence</i>	<i>Melting Point (°C)</i>
Aluminum	Al	13	26.98	2.71	FCC	0.143	0.053	3+	660.4
Argon	Ar	18	39.95	—	—	—	—	Inert	-189.2
Barium	Ba	56	137.33	3.5	BCC	0.217	0.136	2+	725
Beryllium	Be	4	9.012	1.85	HCP	0.114	0.035	2+	1278
Boron	B	5	10.81	2.34	Rhomb.	—	0.023	3+	2300
Bromine	Br	35	79.90	—	—	—	0.196	1-	-7.2
Cadmium	Cd	48	112.41	8.65	HCP	0.149	0.095	2+	321
Calcium	Ca	20	40.08	1.55	FCC	0.197	0.100	2+	839
Carbon	C	6	12.011	2.25	Hex.	0.071	~0.016	4+	(sublimes at 3367)
Cesium	Cs	55	132.91	1.87	BCC	0.265	0.170	1+	28.4
Chlorine	Cl	17	35.45	—	—	—	0.181	1-	-101
Chromium	Cr	24	52.00	7.19	BCC	0.125	0.063	3+	1875
Cobalt	Co	27	58.93	8.9	HCP	0.125	0.072	2+	1495
Copper	Cu	29	63.55	8.94	FCC	0.128	0.096	1+	1085
Fluorine	F	9	19.00	—	—	—	0.133	1-	-220
Gallium	Ga	31	69.72	5.90	Ortho.	0.122	0.062	3+	29.8
Germanium	Ge	32	72.59	5.32	Dia. cubic	0.122	0.053	4+	937
Gold	Au	79	196.97	19.32	FCC	0.144	0.137	1+	1064
Helium	He	2	4.003	—	—	—	—	Inert	-272 (at 26 atm)
Hydrogen	H	1	1.008	—	—	—	0.154	1+	-259
Iodine	I	53	126.91	4.93	Ortho.	0.136	0.220	1-	114
Iron	Fe	26	55.85	7.87	BCC	0.124	0.077	2+	1538
Lead	Pb	82	207.2	11.35	FCC	0.175	0.120	2+	327
Lithium	Li	3	6.94	0.534	BCC	0.152	0.068	1+	181
Magnesium	Mg	12	24.31	1.74	HCP	0.160	0.072	2+	649
Manganese	Mn	25	54.94	7.44	Cubic	0.112	0.067	2+	1244
Mercury	Hg	80	200.59	—	—	—	0.110	2+	-38.8
Molybdenum	Mo	42	95.94	10.22	BCC	0.136	0.070	4+	2617
Neon	Ne	10	20.18	—	—	—	—	Inert	-248.7
Nickel	Ni	28	58.69	8.90	FCC	0.125	0.069	2+	1455
Niobium	Nb	41	92.91	8.57	BCC	0.143	0.069	5+	2468
Nitrogen	N	7	14.007	—	—	—	0.01-0.02	5+	-209.9
Oxygen	O	8	16.00	—	—	—	0.140	2-	-218.4
Phosphorus	P	15	30.97	1.82	Ortho.	0.109	0.035	5+	44.1
Platinum	Pt	78	195.08	21.45	FCC	0.139	0.080	2+	1772
Potassium	K	19	39.10	0.862	BCC	0.231	0.138	1+	63
Silicon	Si	14	28.09	2.33	Dia. cubic	0.118	0.040	4+	1410
Silver	Ag	47	107.87	10.49	FCC	0.144	0.126	1+	962
Sodium	Na	11	22.99	0.971	BCC	0.186	0.102	1+	98
Sulfur	S	16	32.06	2.07	Ortho.	0.106	0.184	2-	113
Tin	Sn	50	118.69	7.17	Tetra.	0.151	0.071	4+	232
Titanium	Ti	22	47.88	4.51	HCP	0.145	0.068	4+	1668
Tungsten	W	74	183.85	19.3	BCC	0.137	0.070	4+	3410
Vanadium	V	23	50.94	6.1	BCC	0.132	0.059	5+	1890
Zinc	Zn	30	65.39	7.13	HCP	0.133	0.074	2+	420
Zirconium	Zr	40	91.22	6.51	HCP	0.159	0.079	4+	1852

Centroids of Areas of Common Shapes

Rectangle

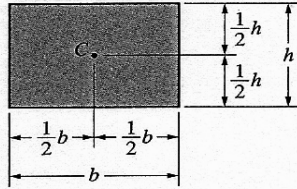

$$A = bh$$

Triangle

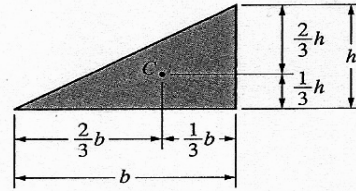

$$A = \frac{1}{2}bh$$

Circle

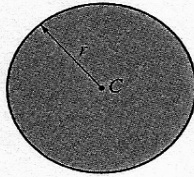

$$A = \pi r^2$$

Semicircle

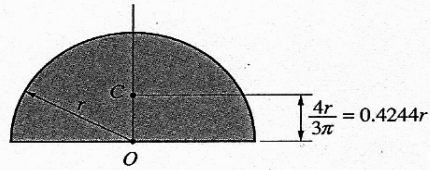

$$A = \frac{1}{2}\pi r^2$$

Quarter-Circle

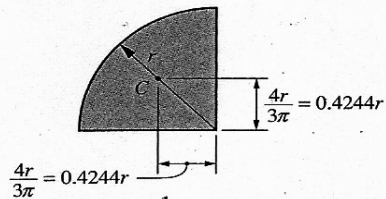

$$A = \frac{1}{4}\pi r^2$$

Sectors

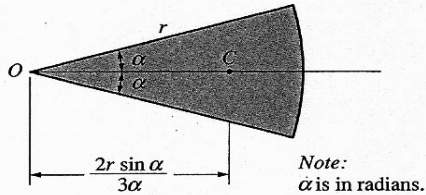

$$A = \alpha r^2$$

Semiparabolic Area

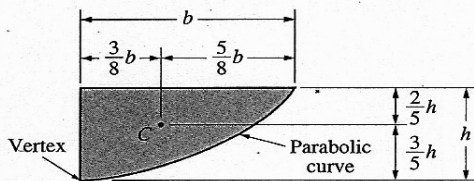

$$A = \frac{2}{3}bh$$

Parabolic Spandrel

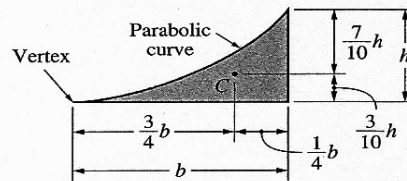

$$A = \frac{1}{3}bh$$

Properties of Areas of Common Shapes

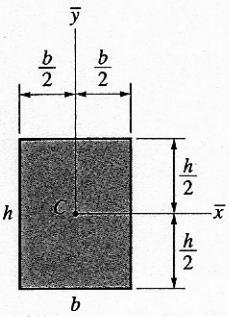
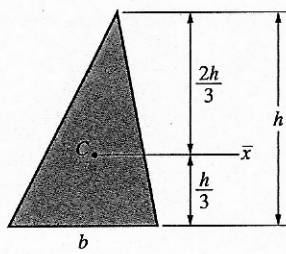
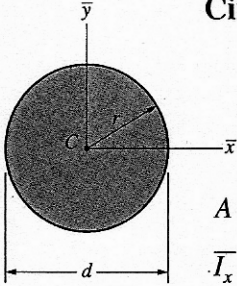
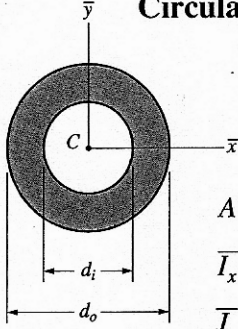
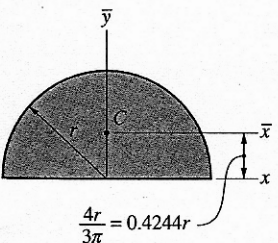
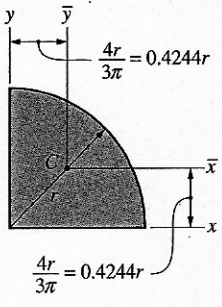
<p style="text-align: center;">Rectangle</p>  $A = bh$ $\bar{I}_x = \frac{1}{12}bh^3$ $\bar{I}_y = \frac{1}{12}hb^3$ $\bar{J} = \frac{1}{12}bh(h^2 + b^2)$ $\bar{r}_x = \frac{h}{\sqrt{12}}$ $\bar{r}_y = \frac{b}{\sqrt{12}}$	<p style="text-align: center;">Triangle</p>  $A = \frac{1}{2}bh$ $\bar{I}_x = \frac{1}{36}bh^3$ $\bar{r}_x = \frac{h}{\sqrt{18}}$
<p style="text-align: center;">Circle</p>  $A = \frac{1}{4}\pi d^2 = \pi r^2$ $\bar{I}_x = \bar{I}_y = \frac{1}{64}\pi d^4 = \frac{1}{4}\pi r^4$ $\bar{J} = \frac{1}{32}\pi d^4 = \frac{1}{2}\pi r^4$ $\bar{r}_x = \bar{r}_y = \frac{1}{4}d$	<p style="text-align: center;">Circular Ring</p>  $A = \frac{1}{4}\pi(d_o^2 - d_i^2)$ $\bar{I}_x = \bar{I}_y = \frac{1}{64}\pi(d_o^4 - d_i^4)$ $\bar{J} = \frac{1}{32}\pi(d_o^4 - d_i^4)$ $\bar{r}_x = \bar{r}_y = \frac{1}{4}\sqrt{d_o^2 + d_i^2}$
<p style="text-align: center;">Semicircle</p>  $A = \frac{1}{2}\pi r^2$ $\bar{I}_x = 0.1098r^4$ $\bar{I}_y = \bar{I}_x = \frac{1}{8}\pi r^4$ $\bar{J} = 0.5025r^4$ $\bar{r}_x = 0.2644r$ $\bar{r}_y = r_x = \frac{1}{2}r$	<p style="text-align: center;">Quarter-Circle</p>  $A = \frac{1}{4}\pi r^2$ $\bar{I}_x = \bar{I}_y = 0.0549r^4$ $I_x = I_y = \frac{1}{16}\pi r^4$ $\bar{J} = 0.1098r^4$ $\bar{r}_x = \bar{r}_y = 0.2644r$ $r_x = r_y = \frac{1}{2}r$

Lampiran D: Formula untuk Lenturan Rasuk
Appendix D

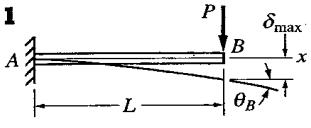
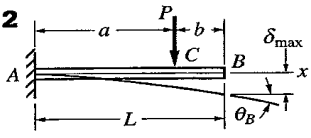
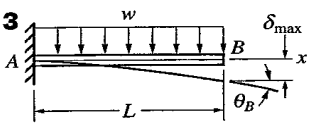
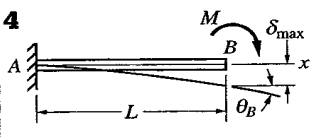
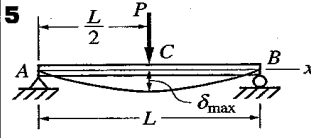
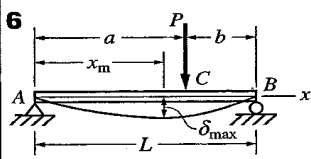
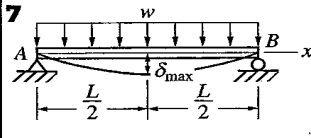
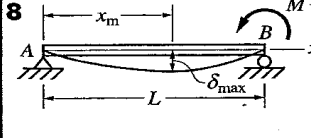
Beam Loading and Deflection	Maximum Deflection	Slope at End(s)	Deflection Equations
	$\delta_{\max} = \frac{PL^3}{3EI}$	$\theta_B = \frac{PL^2}{2EI}$	$\delta = \frac{Px^2}{6EI}(3L - x)$
	$\delta_{\max} = \frac{P\alpha^2}{6EI}(3L - \alpha)$	$\theta_B = \frac{P\alpha^2}{2EI}$	$\delta_{AC} = \frac{Px^2}{6EI}(3\alpha - x)$ $\delta_{CB} = \frac{P\alpha^2}{6EI}(3x - \alpha)$
	$\delta_{\max} = \frac{wL^4}{8EI}$	$\theta_B = \frac{wL^3}{6EI}$	$\delta = \frac{wx^2}{24EI}(x^2 - 4Lx + 6L^2)$
	$\delta_{\max} = \frac{ML^2}{2EI}$	$\theta_B = \frac{ML}{EI}$	$\delta = \frac{Mx^2}{2EI}$
	$\delta_{\max} = \frac{PL^3}{48EI}$	$\theta_A = \theta_B = \frac{PL^2}{16EI}$	$\delta_{AC} = \frac{Px}{48EI}(3L^2 - 4x^2)$
	<p>For $\alpha > b$:</p> $\delta_{\max} = \frac{Pb(L^2 - b^2)^{3/2}}{9\sqrt{3}EIL}$ at $x_m = \sqrt{\frac{L^2 - b^2}{3}}$	$\theta_A = \frac{Pb(L^2 - b^2)}{6EIL}$ $\theta_B = \frac{P\alpha(L^2 - \alpha^2)}{6EIL}$	$\delta_{AC} = \frac{Pbx}{6EIL}(L^2 - x^2 - b^2)$ $\delta_{CB} = \frac{Pb}{6EIL} \left[\frac{L}{b}(x - \alpha)^3 + (L^2 - b^2)x - x^3 \right]$
	$\delta_{\max} = \frac{5wL^4}{384EI}$	$\theta_A = \theta_B = \frac{wL^3}{24EI}$	$\delta = \frac{wx}{24EI}(L^3 + x^3 - 2Lx^2)$
	$\delta_{\max} = \frac{ML^2}{9\sqrt{3}EI}$ at $x_m = \frac{L}{\sqrt{3}}$	$\theta_A = \frac{ML}{6EI}$ $\theta_B = \frac{ML}{3EI}$	$\delta = \frac{Mx}{6EIL}(L^2 - x^2)$